

# FSCM0765R

## Green Mode Fairchild Power Switch (FPS™)

### Features

- Internal Avalanche Rugged SenseFET
- Low Start-up Current (max 40uA)
- Low Power Consumption under 1 W at 240VAC and 0.4W Load
- Precise Fixed Operating Frequency (66kHz)
- Frequency Modulation for low EMI
- Pulse by Pulse Current Limiting (Adjustable)
- Over Voltage Protection (OVP)
- Over Load Protection (OLP)
- Thermal Shutdown Function (TSD)
- Auto-Restart Mode
- Under Voltage Lock Out (UVLO) with Hysteresis
- Built-in Soft Start (15ms)

### Application

- SMPS for VCR, SVR, STB, DVD and DVCD
- Adaptor
- SMPS for LCD Monitor

### Related Application Notes

- [AN-4137](#): Design Guidelines for Off-line Flyback Converters Using Fairchild Power Switch (FPS)
- [AN-4140](#): Transformer Design Consideration for off-line Flyback Converters using Fairchild Power Switch
- [AN-4141](#): Troubleshooting and Design Tips for Fairchild Power Switch Flyback Applications
- [AN-4148](#): Audible Noise Reduction Techniques for FPS Applications

### Description

The FSCM0765R is an integrated Pulse Width Modulator (PWM) and SenseFET specifically designed for high performance offline Switch Mode Power Supplies (SMPS) with minimal external components. This device is an integrated high voltage power switching regulator which combines an avalanche rugged SenseFET with a current mode PWM control block. The PWM controller includes integrated fixed frequency oscillator, under voltage lockout, leading edge blanking (LEB), optimized gate driver, internal soft start, temperature compensated precise current sources for a loop compensation, and self protection circuitry. Compared with a discrete MOSFET and PWM controller solution, it can reduce total cost, component count, size, and weight while simultaneously increasing efficiency, productivity, and system reliability. This device is a basic platform well suited for cost effective designs of flyback converters.

**OUTPUT POWER TABLE**

PRODUCT	230VAC ±15% <sup>(3)</sup>		85-265VAC	
	Adapt-er <sup>(1)</sup>	Open Frame <sup>(2)</sup>	Adapt-er <sup>(1)</sup>	Open Frame <sup>(2)</sup>
FSCM0565RJ	50W	65W	40W	50W
FSCM0765RJ	65W	70W	50W	60W
FSCM0565RI	50W	65W	40W	50W
FSCM0765RI	65W	70W	50W	60W
FSCM0565RG	70W	85W	60W	70W
FSCM0765RG	85W	95W	70W	85W

**Table 1. Maximum Output Power**
**Notes:**

1. Typical continuous power in a non-ventilated enclosed adaptor measured at 50°C ambient.
2. Maximum practical continuous power in an open-frame design at 50°C ambient.
3. 230 VAC or 100/115 VAC with doubler.

### Typical Circuit

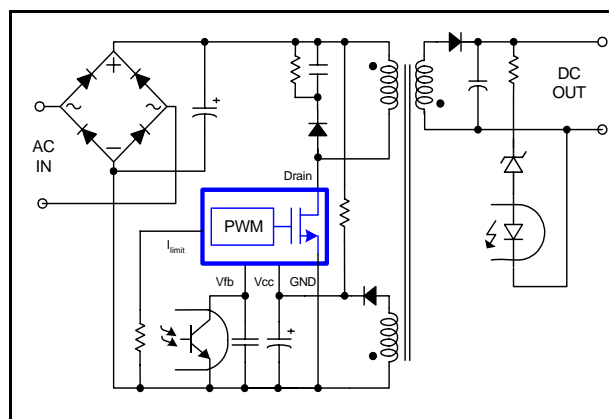
**Figure 1. Typical Flyback Application**

### Internal Block Diagram

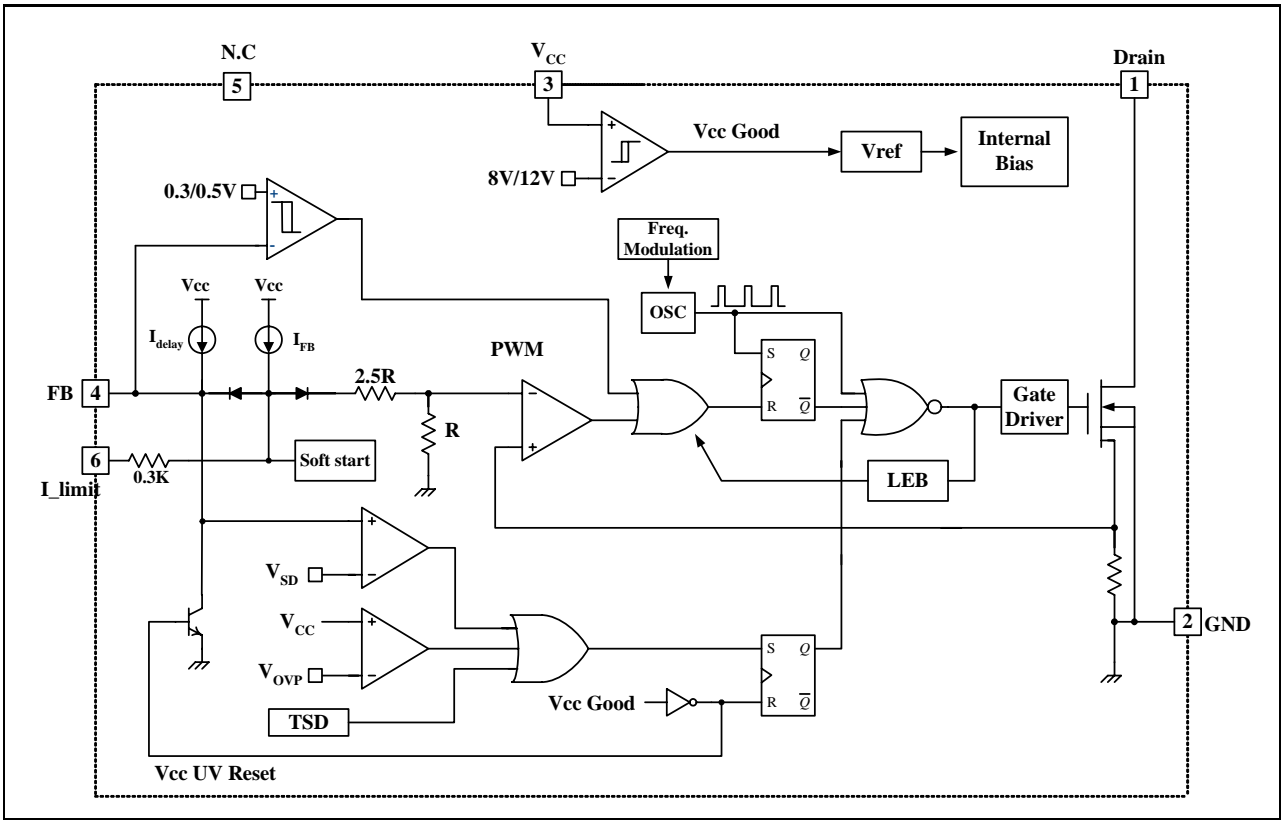

Figure 2. Functional Block Diagram of FSCM0765R

## Pin Definitions

Pin Number	Pin Name	Pin Function Description
1	Drain	This pin is the high voltage power SenseFET drain. It is designed to drive the transformer directly.
2	GND	This pin is the control ground and the SenseFET source.
3	VCC	This pin is the positive supply voltage input. Initially, During start up, the power is supplied through the startup resistor from DC link. When Vcc reaches 12V, the power is supplied from the auxiliary transformer winding.
4	Feedback (FB)	This pin is internally connected to the inverting input of the PWM comparator. The collector of an optocoupler is typically tied to this pin. For stable operation, a capacitor should be placed between this pin and GND. If the voltage of this pin reaches 6.0V, the over load protection is activated resulting in shutdown of the FPS.
5	N.C.	This pin is not connected.
6	I_limit	This pin is for the pulse by pulse current limit level programming. By using a resistor to GND on this pin, the current limit level can be changed. If this pin is left floating, the typical current limit will be 3.0A.

## Pin Configuration

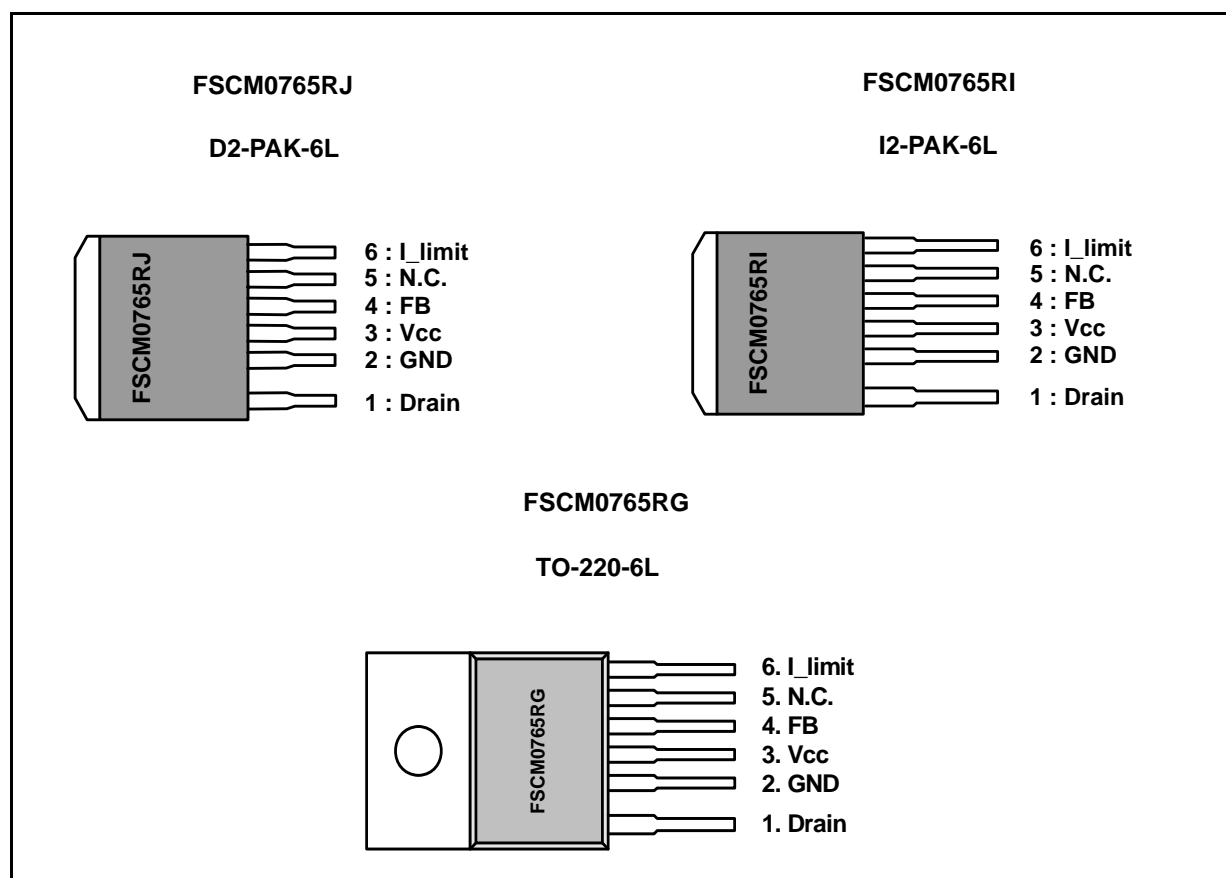

Figure 3. Pin Configuration (Top View) Absolute Maximum Ratings

**FSCM0765R**

(Ta=25°C, unless otherwise specified.)

Parameter	Symbol	Value	Unit
Drain-Source (GND) Voltage <sup>(1)</sup>	V <sub>DSS</sub>	650	V
Drain-Gate Voltage (R <sub>GS</sub> =1MΩ)	V <sub>DGR</sub>	650	V
Gate-Source (GND) Voltage	V <sub>GS</sub>	±30	V
Drain Current Pulsed <sup>(2)</sup>	I <sub>DM</sub>	21	ADC
Continuous Drain Current (D2-PAK, I2-PAK)			
@ T <sub>c</sub> = 25°C	I <sub>D</sub>	5.3	ADC
@ T <sub>c</sub> =100°C	I <sub>D</sub>	3.4	ADC
Continuous Drain Current (TO-220)			
@ T <sub>c</sub> = 25°C	I <sub>D</sub>	7	ADC
@ T <sub>c</sub> =100°C	I <sub>D</sub>	4.4	ADC
Supply Voltage	V <sub>CC</sub>	20	V
Analog Input Voltage Range	V <sub>FB</sub>	-0.3 to V <sub>CC</sub>	V
Total Power Dissipation (D2-PAK,I2-PAK)	P <sub>D</sub>	83	W
Total Power Dissipation (TO-220)	P <sub>D</sub>	145	W
Operating Junction Temperature	T <sub>J</sub>	Internally limited	°C
Operating Ambient Temperature	T <sub>A</sub>	-25 to +85	°C
Storage Temperature Range	T <sub>STG</sub>	-55 to +150	°C
ESD Capability, HBM Model (All pins except Vfb)	-	2.0 (GND-Vfb = 1.5kV) (Vcc-Vfb = 1.0kV)	kV
ESD Capability, Machine Model (All pins except Vfb)	-	300 (GND-Vfb = 250V) (Vcc-Vfb = 100V)	V

**Notes:**

1. T<sub>j</sub> = 25°C to 150°C
2. Repetitive rating: Pulse width limited by maximum junction temperature.

**Thermal Impedance**

Parameter	Symbol	Value	Unit
Junction-to-Ambient Thermal	θ <sub>JA</sub> <sup>(1)</sup>	-	°C/W
Junction-to-Case Thermal (D2-PAK, I2-PAK)	θ <sub>JC</sub> <sup>(2)</sup>	1.5	°C/W
Junction-to-Case Thermal (TO-220)	θ <sub>JC</sub> <sup>(2)</sup>	0.9	°C/W

**Note:**

1. Free standing with no heat-sink under natural convection
2. Infinite cooling condition - Refer to the SEMI G30-88.

## Electrical Characteristics

(Ta = 25°C unless otherwise specified.)

Parameter	Symbol	Condition	Min.	Typ.	Max.	Unit
<b>SenseFET SECTION</b>						
Drain Source Breakdown Voltage	BVDSS	VGS = 0V, ID = 250μA	650	-	-	V
Zero-Gate-Voltage Current	IDSS	VDS = Max, Rating VGS = 0V	-	-	500	μA
Static Drain Source on Resistance <sup>(1)</sup>	RDS(ON)	VGS = 10V, ID = 2.3A	-	1.4	1.6	Ω
Output Capacitance	COSS	VGS = 0V, VDS = 25V, f = 1MHz	-	100	-	pF
Turn on Delay Time	TD(ON)	VDD = 325V, ID = 5A (MOSFET switching time is essentially independent of operating temperature)	-	25	-	ns
Rise Time	TR		-	60	-	
Turn off Delay Time	TD(OFF)		-	115	-	
Fall Time	TF		-	65	-	
<b>CONTROL SECTION</b>						
Initial Frequency	FOSC	VCC = 14V, VFB = 5V	60	66	72	kHz
Modulated Frequency Range	ΔFmod	-	-	±3	-	kHz
Frequency Modulation Cycle	Tmod	-	-	4	-	ms
Voltage Stability	FSTABLE	10V ≤ VCC ≤ 17V	0	1	3	%
Temperature Stability <sup>(2)</sup>	ΔFOSC	-25°C ≤ Ta ≤ +85°C	-	±5	±10	%
Maximum Duty Cycle	DMAX	-	75	80	85	%
Minimum Duty Cycle	DMIN	-	-	-	0	%
Start Threshold Voltage	VSTART	VFB = GND	11	12	13	V
Stop Threshold Voltage	VSTOP	VFB = GND	7	8	9	V
Feedback Source Current	IFB	VFB = GND	0.7	0.9	1.1	mA
Soft-start Time	TSS	-	10	15	20	ms
Initial Frequency	TLEB	-	-	300	-	ns
<b>BURST MODE SECTION</b>						
Burst Mode Voltages <sup>(2)</sup>	VBH	Vcc = 14V	0.4	0.5	0.6	V
	VBL	Vcc = 14V	0.24	0.3	0.36	V

### Notes:

1. Pulse Test: Pulse width ≤ 300μS, duty ≤ 2%
2. These parameters, although guaranteed at the design, are not tested in mass production.

## FSCM0765R

PROTECTION SECTION						
Peak Current Limit <sup>(2)</sup>	ILIM	VCC = 14V, VFB = 5V	2.64	3	3.36	A
Over Voltage Protection	VOVP	-	18	19	20	V
Thermal Shutdown Temperature <sup>(1)</sup>	TSD		130	145	160	°C
Shutdown Delay Current	IDELAY	VFB = 4V	3.5	5.3	7	μA
Shutdown Feedback Voltage	VSD	VFB ≥ 5.5V	5.5	6	6.5	V
TOTAL DEVICE SECTION						
Startup Current	Istart		-	20	40	μA
Operating Supply Current <sup>(3)</sup>	IOP(MIN)	VCC = 10V, VFB = 0V	-	2.5	5	mA
	IOP(MAX)	VCC = 20V, VFB = 0V				

**Notes:**

1. These parameters, although guaranteed at the design, are not tested in mass production.
2. These parameters indicate the inductor current.
3. This parameter is the current flowing into the control IC.

---

**Comparison Between FSDM07652R and FSCM0765R**

Function	FSDM07652R	FSCM0765R
Frequency Modulation	N/A	Available <ul style="list-style-type: none"><li>• Modulated frequency range (<math>DF_{mod}</math>) = <math>\pm 3\text{kHz}</math></li><li>• Frequency modulation cycle (<math>T_{mod}</math>) = 4ms</li></ul>
Pulse-by-pulse Current Limit	• Internally fixed (2.5A)	• Programmable using external resistor (3A max)
Internal Startup Circuit	• Available	• N/A (Requires a startup resistor) <ul style="list-style-type: none"><li>• Startup current: 40uA (max)</li></ul>

## Typical Performance Characteristics

(These Characteristic Graphs are Normalized at Ta= 25°C.)

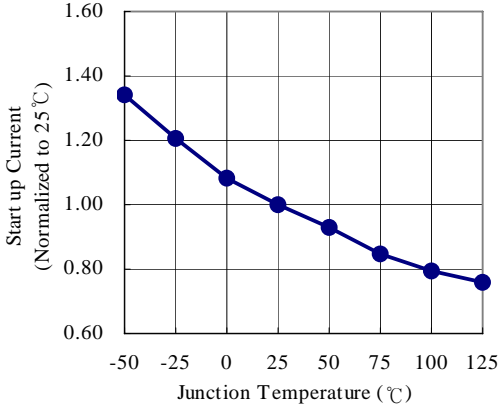

Figure 4. Startup Current vs. Temp

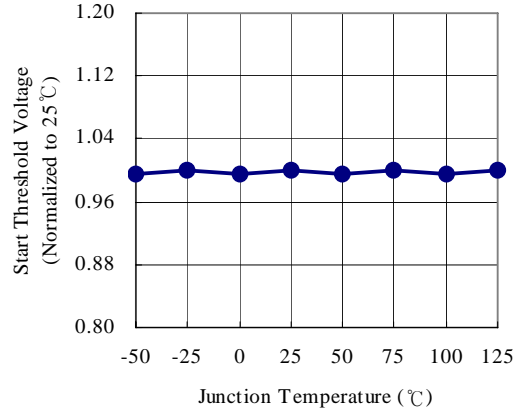

Figure 7. Start Threshold Voltage vs. Temp

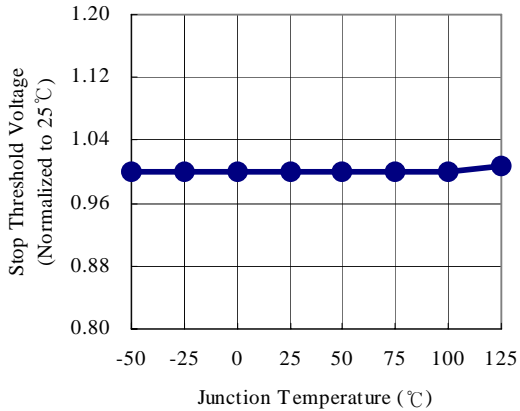

Figure 5. Stop Threshold Voltage vs. Temp

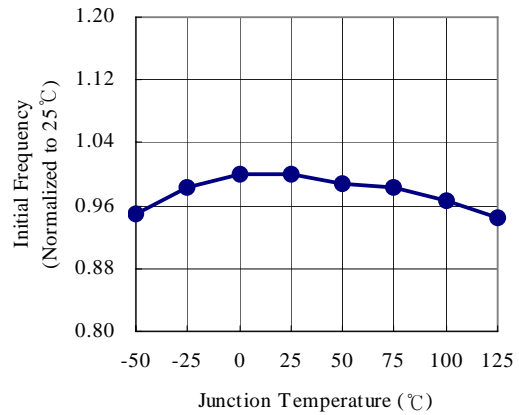

Figure 8. Initial Frequency vs. Temp

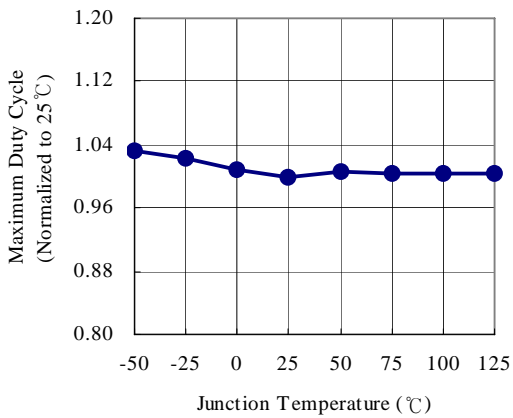

Figure 6. Maximum Duty Cycle vs. Temp

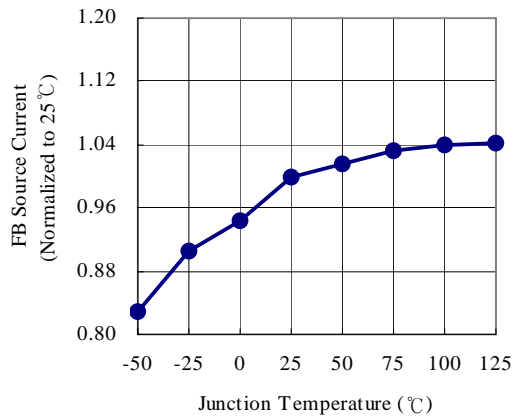

Figure 9. Feedback Source Current vs. Temp



## Typical Performance Characteristics (Continued)

(These Characteristic Graphs are Normalized at Ta= 25°C.)

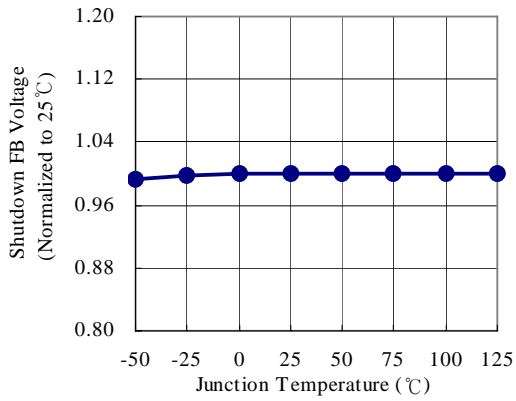

Figure 10. ShutDown Feedback Voltage vs. Temp

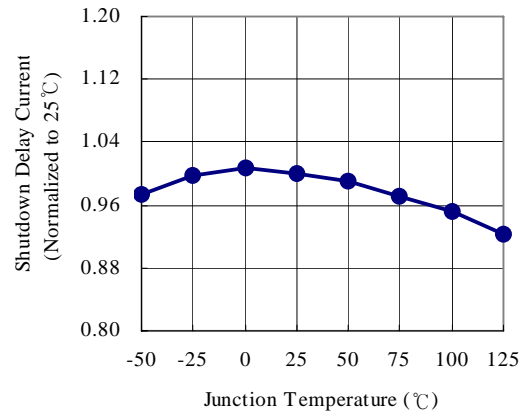

Figure 13. ShutDown Delay Current vs. Temp

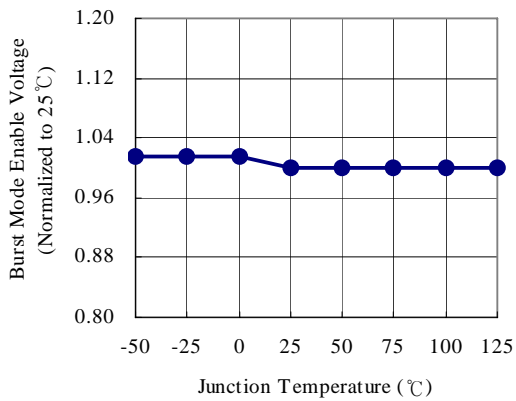

Figure 11. Burst Mode Enable Voltage vs. Temp

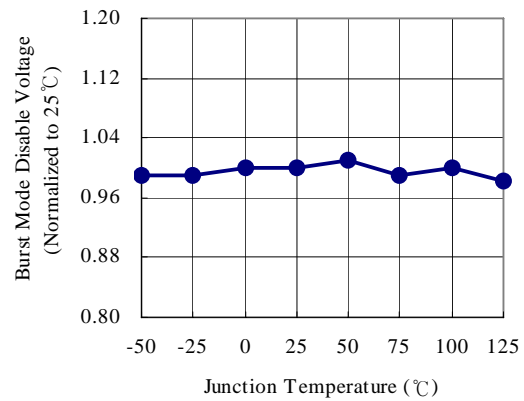

Figure 14. Burst Mode Disable Voltage vs. Temp

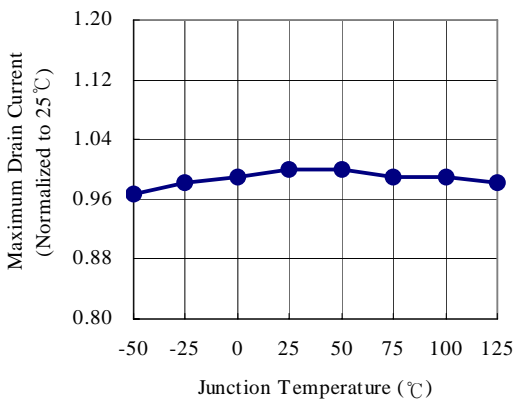

Figure 12. Macimum Drain Current vs. Temp

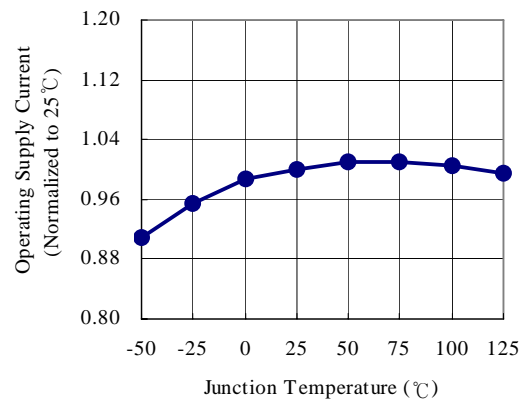

Figure 15. Operating Supply Current vs. Temp

## Functional Description

**1. Startup:** Figure 16 shows the typical startup circuit and transformer auxiliary winding for the FSCM0765R application. Before the FSCM0765R begins switching, it consumes only startup current (typically 25uA) and the current supplied from the DC link supply current consumed by the FPS (I<sub>cc</sub>), and charges the external capacitor (C<sub>a</sub>) that is connected to the V<sub>cc</sub> pin. When V<sub>cc</sub> reaches start voltage of 12V (V<sub>START</sub>), the FSCM0765R begins switching, and the current consumed by FSCM0765R increases to 3mA. Then, the FSCM0765R continues its normal switching operation and the power required for this device is supplied from the transformer auxiliary winding, unless V<sub>cc</sub> drops below the stop voltage of 8V (V<sub>STOP</sub>). To guarantee the stable operation of the control IC, V<sub>cc</sub> has under voltage lockout (UVLO) with 4V hysteresis. Figure 17 shows the relation between the current consumed by the FPS (I<sub>cc</sub>) and the supply voltage (V<sub>cc</sub>).

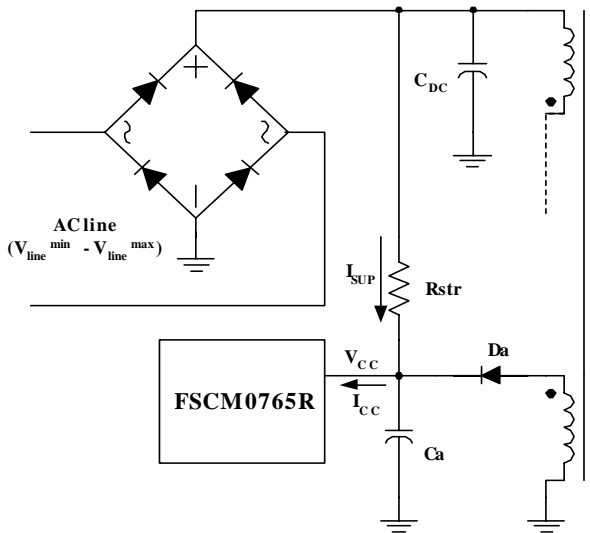

Figure 16. Startup Circuit

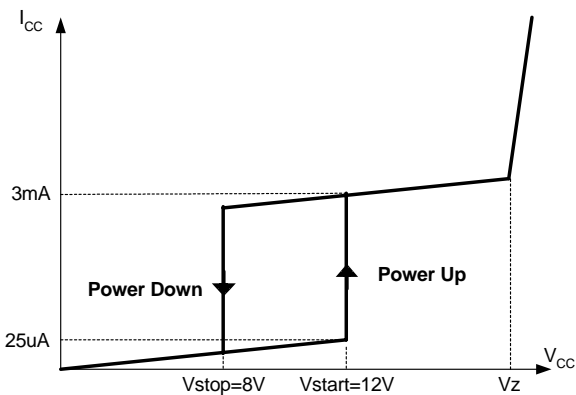

Figure 17. Relation Between Operating Supply Current and V<sub>cc</sub> Voltage

The minimum current supplied through the startup resistor is given by

$$I_{sup}^{min} = (\sqrt{2} \cdot V_{line}^{min} - V_{start}) \cdot \frac{1}{R_{str}}$$

where  $V_{line}^{min}$  is the minimum input voltage,  $V_{start}$  is the start voltage (12V) and  $R_{str}$  is the startup resistor. The startup resistor should be chosen so that  $I_{sup}^{min}$  is larger than the maximum startup current (40uA). If not, V<sub>cc</sub> can not be charged to the start voltage and FPS will fail to start up.

**2. Feedback Control:** The FSCM0765R employs current mode control, as shown in Figure 18. An opto-coupler (such as the H11A817A) and a shunt regulator (such as the KA431) are typically used to implement the feedback network. Comparing the feedback voltage with the voltage across the R<sub>sense</sub> resistor makes it possible to control the switching duty cycle. When the reference pin voltage of the KA431 exceeds the internal reference voltage of 2.5V, the H11A817A LED current increases, thus pulling down the feedback voltage and reducing the duty cycle. This event typically happens when the input voltage is increased or the output load is decreased.

**2.1 Pulse-by-pulse Current Limit:** Because current mode control is employed, the peak current through the SenseFET is determined by the inverting input of the PWM comparator (V<sub>fb</sub>\*) as shown in Figure 18. When the current through the opto transistor is zero and the current limit pin (#5) is left floating, the feedback current source (I<sub>FB</sub>) of 0.9mA flows only through the internal resistor (R+2.5R=2.8k). In this case, the cathode voltage of diode D2 and the peak drain current have maximum values of 2.5V and 3A, respectively. The pulse-by-pulse current limit can be adjusted using a resistor to GND on the current limit pin (#5). The current limit level using an external resistor (R<sub>LIM</sub>) is given by:

$$I_{LIM} = \frac{R_{LIM} \cdot 3A}{2.8k\Omega + R_{LIM}}$$

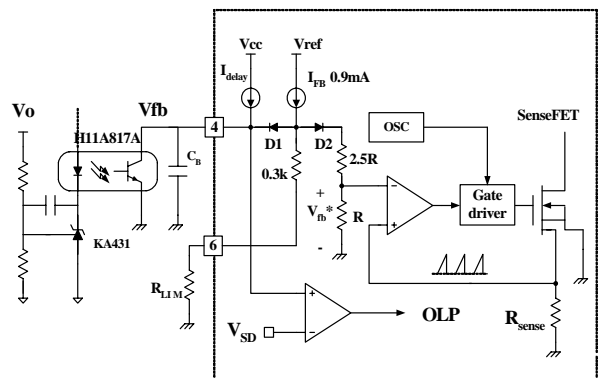

Figure 18. Pulse Width Modulation (PWM) Circuit

## FSCM0765R

**2.2 Leading Edge Blanking (LEB):** At the instant the internal SenseFET is turned on, there usually exists a high current spike through the SenseFET, caused by primary-side capacitance and secondary-side rectifier reverse recovery. Excessive voltage across the Rsense resistor can lead to incorrect feedback operation in the current mode PWM control. To counter this effect, the FSCM0765R employs a leading edge blanking (LEB) circuit. This circuit inhibits the PWM comparator for a short time ( $T_{LEB}$ ) after the SenseFET is turned on.

**3. Protection Circuit:** The FSCM0765R has several self protective functions such as over load protection (OLP), over voltage protection (OVP) and thermal shutdown (TSD). Because these protection circuits are fully integrated into the IC without external components, the reliability can be improved without increasing cost. Once the fault condition occurs, switching is terminated and the SenseFET remains off. This causes Vcc to fall. When Vcc reaches the UVLO stop voltage of 8V, the current consumed by the FSCM0765R decreases to the startup current (typically 25uA) and the current supplied from the DC link charges the external capacitor ( $C_a$ ) that is connected to the Vcc pin. When Vcc reaches the start voltage of 12V, the FSCM0765R resumes its normal operation. In this manner, the auto-restart can alternately enable and disable the switching of the power SenseFET until the fault condition is eliminated (see Figure 19).

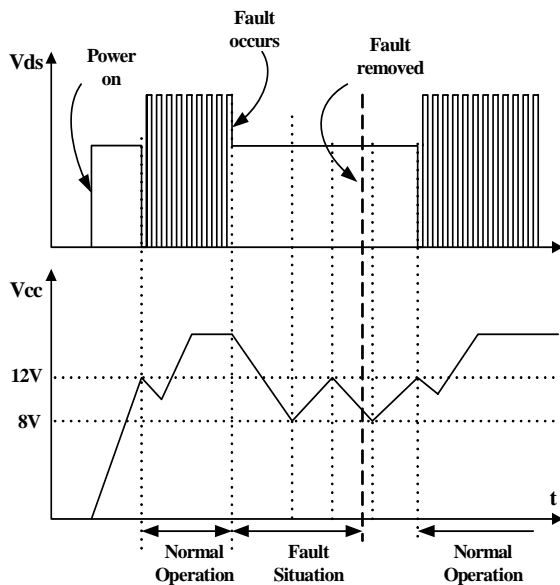

Figure 19. Auto Restart Operation

**3.1 Over Load Protection (OLP):** Overload is defined as the load current exceeding a pre-set level due to an unexpected event. In this situation, the protection circuit should be activated to protect the SMPS. However, even when the SMPS is in the normal operation, the over load protection circuit can be activated during the load transition.

To avoid this undesired operation, the over load protection circuit is designed to be activated after a specified time to determine whether it is a transient situation or an overload situation. Because of the pulse-by-pulse current limit capability, the maximum peak current through the SenseFET is limited, and therefore the maximum input power is restricted with a given input voltage. If the output consumes beyond this maximum power, the output voltage ( $V_o$ ) decreases below the set voltage. This reduces the current through the opto-coupler LED, which also reduces the opto-coupler transistor current, thus increasing the feedback voltage ( $V_{fb}$ ). If  $V_{fb}$  exceeds 2.5V, D1 is blocked and the 5.3uA current source ( $I_{delay}$ ) starts to charge  $C_B$  slowly up to  $V_{cc}$ . In this condition,  $V_{fb}$  continues increasing until it reaches 6V, when the switching operation is terminated as shown in Figure 20. The delay time for shutdown is the time required to charge  $C_B$  from 2.5V to 6.0V with 5.3uA ( $I_{delay}$ ). In general, a 10 ~ 50 ms delay time is typical for most applications.

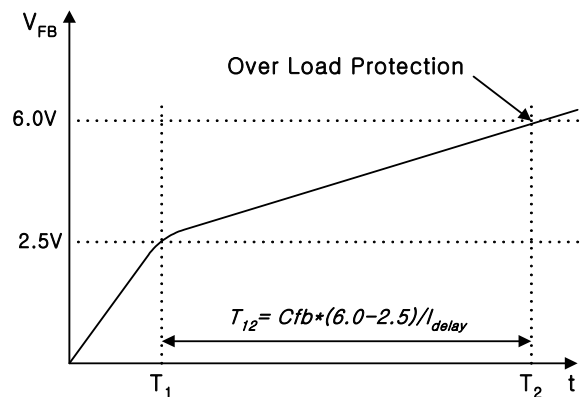

Figure 20. Over Load Protection

**3.2 Over Voltage Protection (OVP):** If the secondary side feedback circuit were to malfunction or a solder defect caused an open in the feedback path, the current through the opto-coupler transistor becomes almost zero. Then,  $V_{fb}$  climbs up in a similar manner to the over load situation, forcing the preset maximum current to be supplied to the SMPS until the over load protection is activated. Because more energy than required is provided to the output, the output voltage may exceed the rated voltage before the over load protection is activated, resulting in the breakdown of the devices in the secondary side. To prevent this situation, an over voltage protection (OVP) circuit is employed. In general,  $V_{cc}$  is proportional to the output voltage and the FSCM0765R uses  $V_{cc}$  instead of directly monitoring the output voltage. If  $V_{CC}$  exceeds 19V, an OVP circuit is activated resulting in the termination of the switching operation. To avoid undesired activation of OVP during normal operation,  $V_{cc}$  should be designed to be below 19V.

**3.3 Thermal Shutdown (TSD):** The SenseFET and the control IC are built in one package. This makes it easy for the control IC to detect the heat generation from the SenseFET. When the temperature exceeds approximately 145°C, the thermal protection is triggered resulting in shutdown of the FPS.

**4. Frequency Modulation:** EMI reduction can be accomplished by modulating the switching frequency of a switched power supply. Frequency modulation can reduce EMI by spreading the energy over a wider frequency range than the band width measured by the EMI test equipment. The amount of EMI reduction is directly related to the depth of the reference frequency. As can be seen in Figure 21, the frequency changes from 63kHz to 69kHz in 4ms.

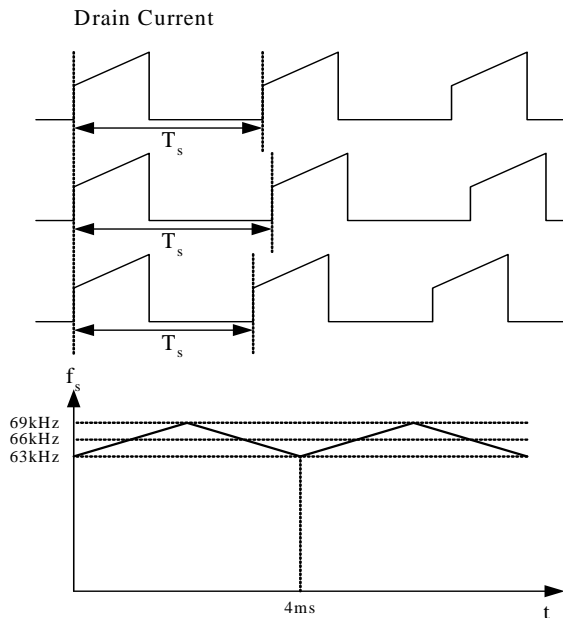

Figure 21. Frequency Modulation

**5. Soft Start:** The FSCM0765R has an internal soft start circuit that increases PWM comparator inverting input voltage together with the SenseFET current slowly after it starts up. The typical soft start time is 15ms. The pulse width to the power switching device is progressively increased to establish the correct working conditions for transformers, rectifier diodes and capacitors. The voltage on the output capacitors is progressively increased with the intention of smoothly establishing the required output voltage. Preventing transformer saturation and reducing stress on the secondary diode during start up is also helpful.

**6. Burst Operation:** To minimize power dissipation in standby mode, the FSCM0765R enters into burst mode operation at light load condition. As the load decreases, the feedback voltage decreases. As shown in Figure 22, the device automatically enters into burst mode when the

feedback voltage drops below VBL (300mV). At this point switching stops and the output voltages tend to drop at a rate dependent on standby current load. This causes the feedback voltage to rise. Once it passes VBH (500mV), switching resumes. The feedback voltage then falls, and the process repeats. Burst mode operation alternately enables and disables switching of the power SenseFET, thereby reducing switching loss in standby mode.

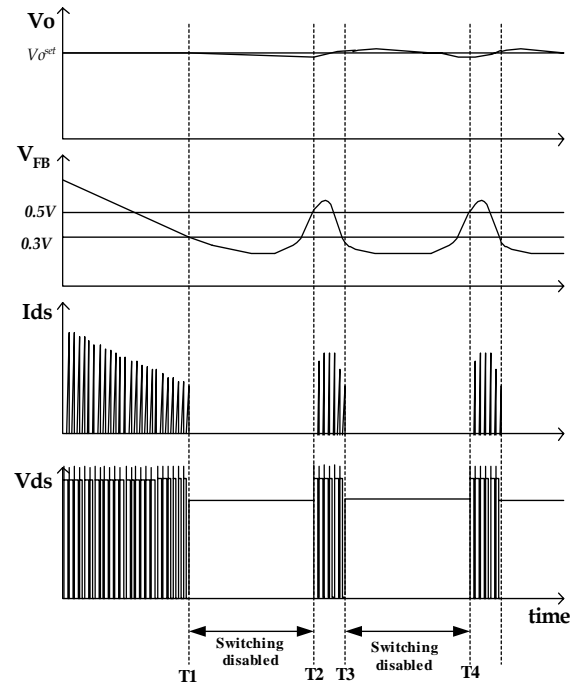

Figure 22. Waveforms of Burst Operation

## Typical application circuit

Application	Output Power	Input Voltage	Output Voltage (Max Current)
LCD Monitor	40W	Universal Input (85-265Vac)	5V (2.0A)
			12V (2.5A)

### Features

- High efficiency (>81% at 85Vac input)
- Low standby mode power consumption (<1W at 240Vac input and 0.4W load)
- Low component count
- Enhanced system reliability through various protection functions
- Low EMI through frequency modulation
- Internal soft-start (15ms)

### Key Design Notes

- Resistors R102 and R105 are employed to prevent start-up at low input voltage
- The delay time for over load protection is designed to be about 50ms with C106 of 47nF. If a faster triggering of OLP is required, C106 can be reduced to 22nF.

### 1. Schematic

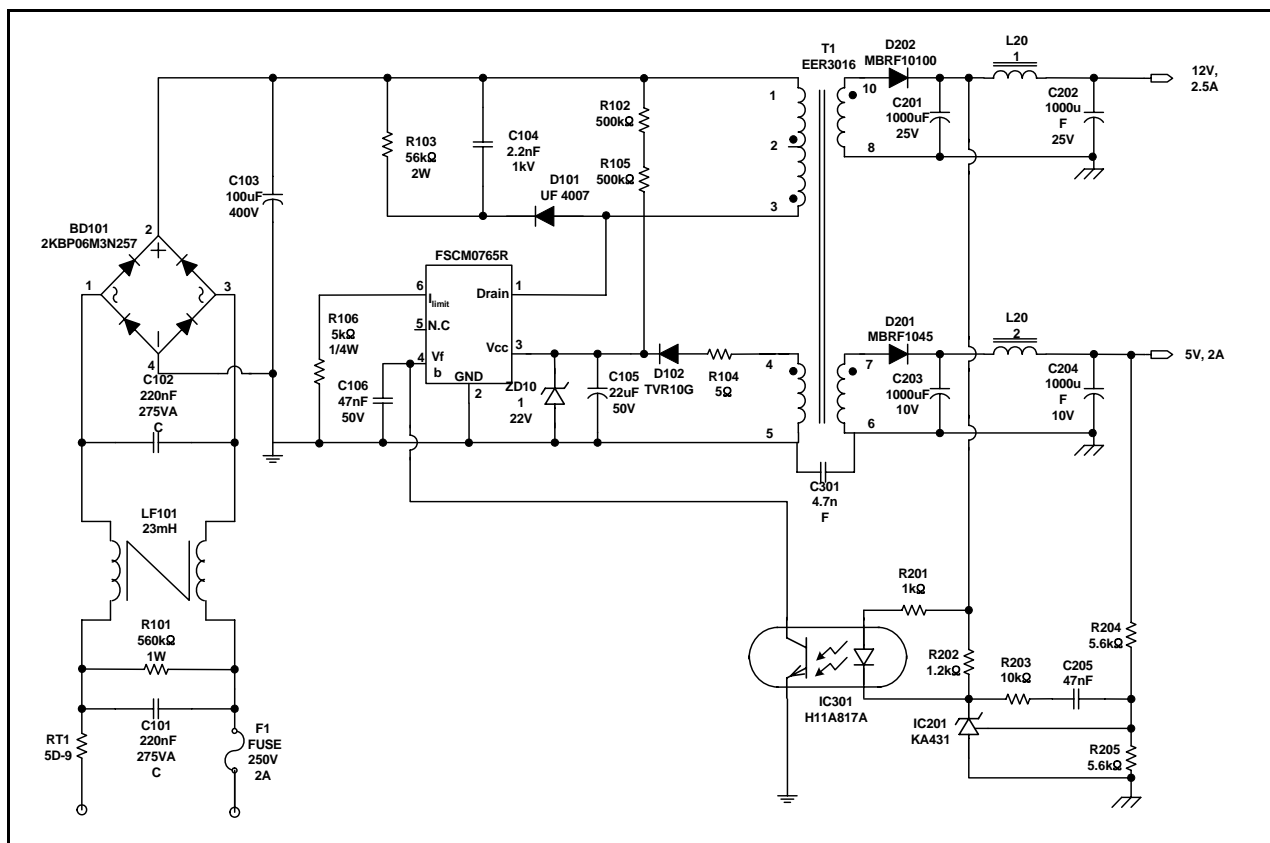

Figure 23. Demo Circuit

FSCM0765R

## 2. Transformer

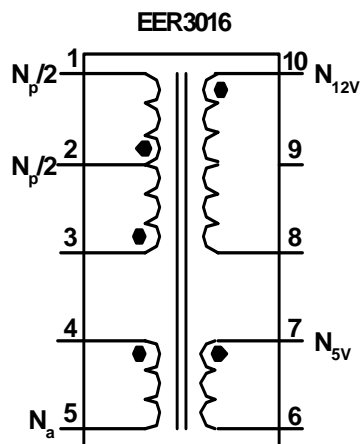

Figure 24. Transformer Schematic Diagram

## 3. Winding Specification

No	Pin (s→f)	Wire	Turns	Winding Method
Na	4 → 5	0.2 <sup>φ</sup> × 1	8	Center Winding
Insulation: Polyester Tape t = 0.050mm, 2Layers				
Np/2	2 → 1	0.4 <sup>φ</sup> × 1	18	Solenoid Winding
Insulation: Polyester Tape t = 0.050mm, 2Layers				
N12V	10 → 8	0.3 <sup>φ</sup> × 3	7	Center Winding
Insulation: Polyester Tape t = 0.050mm, 2Layers				
N5V	7 → 6	0.3 <sup>φ</sup> × 3	3	Center Winding
Insulation: Polyester Tape t = 0.050mm, 2Layers				
Np/2	3 → 2	0.4 <sup>φ</sup> × 1	18	Solenoid Winding
Outer Insulation: Polyester Tape t = 0.050mm, 2Layers				

## 4. Electrical Characteristics

	Pin	Specification	Remarks
Inductance	1 - 3	520uH ± 10%	100kHz, 1V
Leakage Inductance	1 - 3	10uH Max	2 <sup>nd</sup> all Short

## 5. Core & Bobbin

Core: EER 3016

Bobbin: EER3016

Ae(mm<sup>2</sup>): 96

## 6. Demo Circuit Part List

Part	Value	Note	Part	Value	Note
<b>Fuse</b>			C301	4.7nF	Polyester Film Cap.
F101	2A/250V				
<b>NTC</b>			<b>Inductor</b>		
RT101	5D-9		L201	5uH	Wire 1.2mm
<b>Resistor</b>			L202	5uH	Wire 1.2mm
R101	560K	1W			
R102	500K	1/4W			
R103	56K	2W			
R104	5	1/4W	<b>Diode</b>		
R105	500K	1/4W	D101	UF4007	
R106	5K	1/4W	D102	TVR10G	
R201	1K	1/4W	D201	MBRF1045	
R202	10K	1/4W	D202	MBRF10100	
R203	1.2K	1/4W			
R204	5.6K	1/4W			
R205	5.6K	1/4W	<b>Bridge Diode</b>		
			BD101	2KBP06M 3N257	Bridge Diode
<b>Capacitor</b>			<b>Line Filter</b>		
C101	220nF/275VAC	Box Capacitor	<b>Line Filter</b>		
C102	220nF/275VAC	Box Capacitor	LF101	23mH	Wire 0.4mm
C103	100uF/400V	Electrolytic Capacitor	<b>IC</b>		
C104	10nF/1kV	Ceramic Capacitor	IC101	FSCM0765R	FPS™
C105	22uF/50V	Electrolytic Capacitor	IC201	KA431(TL431)	Voltage Reference
C106	47nF/50V	Ceramic Capacitor	IC301	H11A817A	Opto-coupler
C201	1000uF/25V	Electrolytic Capacitor			
C202	1000uF/25V	Electrolytic Capacitor			
C203	1000uF/10V	Electrolytic Capacitor			
C204	1000uF/10V	Electrolytic Capacitor			
C205	47nF/50V	Ceramic Capacitor			

FSCM0765R

# Package Dimensions

## D2-PAK-6L

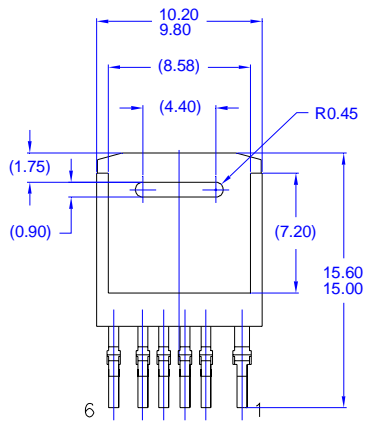
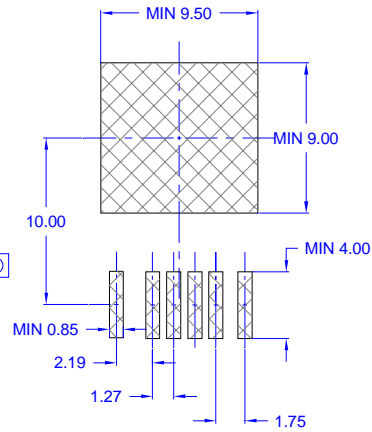
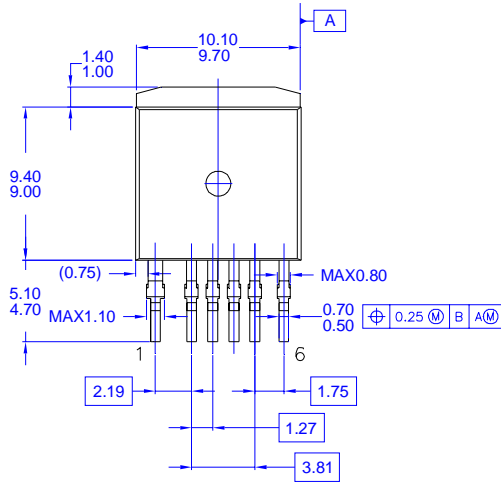

LAND PATTERN RECOMMENDATION

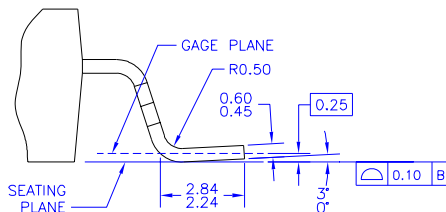
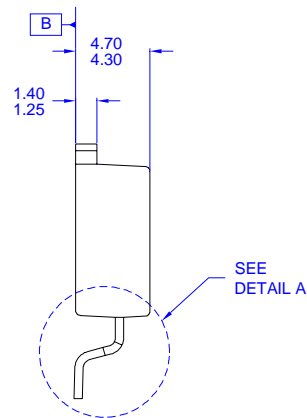

DETAIL A, ROTATED 90°  
SCALE: 2X

- NOTES: UNLESS OTHERWISE SPECIFIED  
 A) THIS PACKAGE DOES NOT COMPLY TO ANY CURRENT PACKAGING STANDARD.  
 B) ALL DIMENSIONS ARE IN MILLIMETERS.  
 C) DIMENSIONS ARE EXCLUSIVE OF BURRS, MOLD FLASH, AND TIE BAR EXTRUSIONS.  
 D) DIMENSIONS AND TOLERANCES PER ASME Y14.5M-1994



Package Dimensions (Continued)

I2-PAK-6L (Forming)

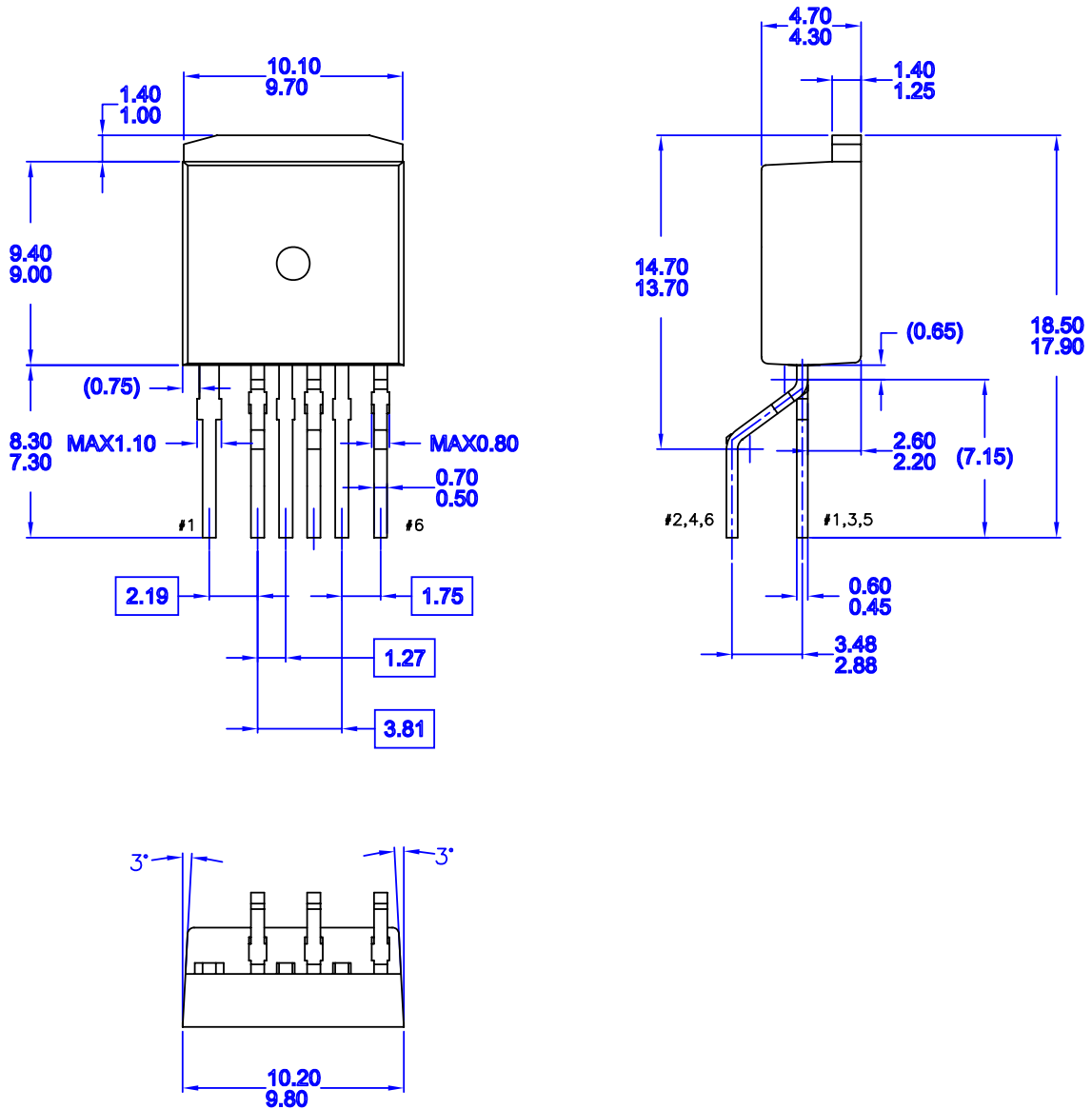

NOTES: UNLESS OTHERWISE SPECIFIED  
 A) THIS PACKAGE DOES NOT COMPLY TO ANY CURRENT PACKAGING STANDARD.  
 B) ALL DIMENSIONS ARE IN MILLIMETERS.  
 C) DIMENSIONS ARE EXCLUSIVE OF BURRS, MOLD FLASH, AND TIE BAR EXTRUSIONS.

MKT-TO262A06



---

**Ordering Information**

Product Number	Package	Marking Code	BVdss	Rds(on) Max.
FSCM0765RJ	D2-PAK-6L	<b>CM0765R</b>	<b>650V</b>	1.6 $\Omega$
FSCM0765RIWDTU	I2-PAK-6L			
FSCM0765RGWDTU	TO-220-6L			

**FSCM0765R**

---

**DISCLAIMER**

FAIRCHILD SEMICONDUCTOR RESERVES THE RIGHT TO MAKE CHANGES WITHOUT FURTHER NOTICE TO ANY PRODUCTS HEREIN TO IMPROVE RELIABILITY, FUNCTION OR DESIGN. FAIRCHILD DOES NOT ASSUME ANY LIABILITY ARISING OUT OF THE APPLICATION OR USE OF ANY PRODUCT OR CIRCUIT DESCRIBED HEREIN; NEITHER DOES IT CONVEY ANY LICENSE UNDER ITS PATENT RIGHTS, NOR THE RIGHTS OF OTHERS.

**LIFE SUPPORT POLICY**

FAIRCHILD'S PRODUCTS ARE NOT AUTHORIZED FOR USE AS CRITICAL COMPONENTS IN LIFE SUPPORT DEVICES OR SYSTEMS WITHOUT THE EXPRESS WRITTEN APPROVAL OF THE PRESIDENT OF FAIRCHILD SEMICONDUCTOR CORPORATION. As used herein:

1. Life support devices or systems are devices or systems which, (a) are intended for surgical implant into the body, or (b) support or sustain life, and (c) whose failure to perform when properly used in accordance with instructions for use provided in the labeling, can be reasonably expected to result in a significant injury of the user.
2. A critical component in any component of a life support device or system whose failure to perform can be reasonably expected to cause the failure of the life support device or system, or to affect its safety or effectiveness.