



# Allwinner V3s Datasheet

---

*Cost-efficient Video Encoding Processor*

Version 1.0

Nov.17,2014

## Declaration

This documentation is the original work and copyrighted property of Allwinner Technology Co.,Ltd.(“Allwinner”). Reproduction in whole or in part must obtain the written approval of Allwinner and give clear acknowledgement to the copyright owner.

The information furnished by Allwinner is believed to be accurate and reliable. Allwinner reserves the right to make changes in circuit design and/or specifications at any time without notice. Allwinner does not assume any responsibility and liability for its use. Nor for any infringements of patents or other rights of the third parties which may result from its use. No license is granted by implication or otherwise under any patent or patent rights of Allwinner. This documentation neither states nor implies warranty of any kind, including fitness for any particular application.

Third party licences may be required to implement the solution/product. Customers shall be solely responsible to obtain all appropriately required third party licences. Allwinner shall not be liable for any licence fee or royalty due in respect of any required third party licence. Allwinner shall have no warranty, indemnity or other obligations with respect to matters covered under any required third party licence.

## Revision History

Version	Date	Description
V1.0	Nov.17,2014	Initial release version

## Table of Contents

Declaration .....	2
Revision History.....	3
Table of Contents .....	4
Chapter 1 About This Documentation .....	36
1.1. Documentation Overview .....	36
1.2. Acronyms and abbreviations.....	36
Chapter 2 Overview .....	40
2.1. Processor Features .....	41
2.1.1. CPU Architecture .....	41
2.1.2. Memory Subsystem.....	41
2.1.2.1. Boot ROM.....	41
2.1.2.2. SDRAM .....	41
2.1.2.3. SD/MMC Interface .....	41
2.1.3. System Peripheral.....	42
2.1.3.1. Timer .....	42
2.1.3.2. High Speed Timer .....	42
2.1.3.3. GIC.....	42
2.1.3.4. DMA .....	42
2.1.3.5. CCU.....	42
2.1.3.6. PWM .....	43
2.1.3.7. RTC .....	43

2.1.3.8.	LRADC.....	43
2.1.3.9.	Crypto Engine.....	43
2.1.4.	Display Subsystem .....	43
2.1.4.1.	Display Engine2.0.....	43
2.1.4.2.	Display Output .....	44
2.1.5.	Video Engine .....	44
2.1.5.1.	Video Decoding.....	44
2.1.5.2.	Video Encoding .....	44
2.1.6.	Image Subsystem.....	44
2.1.6.1.	Image Input.....	44
2.1.6.2.	ISP.....	45
2.1.7.	Audio Subsystem .....	45
2.1.7.1.	Audio codec.....	45
2.1.8.	External Peripherals .....	46
2.1.8.1.	USB.....	46
2.1.8.2.	Ethernet .....	46
2.1.8.3.	UART.....	46
2.1.8.4.	SPI.....	46
2.1.8.5.	TWI.....	47
2.1.9.	Package.....	47
2.2.	System Block Diagram .....	48
Chapter 3	Pin Description .....	49
3.1.	Pin Characteristics.....	49
3.2.	GPIO Multiplex Functions.....	53

3.3.	Detailed Pin/Signal Description.....	55
Chapter 4	System.....	58
4.1.	Memory Mapping .....	59
4.2.	Boot System .....	60
4.3.	CCU.....	61
4.3.1.	Overview .....	61
4.3.2.	Functionalities Description.....	62
4.3.2.1.	System Bus .....	62
4.3.2.2.	Bus clock tree .....	63
4.3.3.	Typical Applications.....	63
4.3.4.	Register List .....	64
4.3.5.	Register Description .....	65
4.3.5.1.	PLL_CPU Control Register (Default Value: 0x00001000) .....	65
4.3.5.2.	PLL_Audio Control Register (Default Value: 0x00035514) .....	66
4.3.5.3.	PLL_VIDEO Control Register (Default Value: 0x03006207).....	67
4.3.5.4.	PLL_VE Control Register (Default Value: 0x03006207).....	68
4.3.5.5.	PLL_DDR0 Control Register (Default Value: 0x00001000).....	69
4.3.5.6.	PLL_PERIPH0 Control Register (Default Value: 0x00041811).....	70
4.3.5.7.	PLL_ISP Control Register (Default Value: 0x03006207).....	72
4.3.5.8.	PLL_PERIPH1 Control Register (Default Value: 0x00041811).....	73
4.3.5.9.	PLL_DDR1 Control Register (Default Value: 0x00001800).....	74
4.3.5.10.	CPU/AXI Configuration Register (Default Value: 0x00010000).....	75
4.3.5.11.	AHB1/APB1 Configuration Register (Default Value: 0x00001010).....	75
4.3.5.12.	APB2 Configuration Register (Default Value: 0x01000000) .....	76

4.3.5.13.	AHB2 Configuration Register (Default Value: 0x00000000) .....	77
4.3.5.14.	Bus Clock Gating Register0 (Default Value: 0x00000000) .....	77
4.3.5.15.	Bus Clock Gating Register1 (Default Value: 0x00000000) .....	78
4.3.5.16.	Bus Clock Gating Register2 (Default Value: 0x00000000) .....	79
4.3.5.17.	Bus Clock Gating Register3 (Default Value: 0x00000000) .....	79
4.3.5.18.	Bus Clock Gating Register4 (Default Value: 0x00000000) .....	80
4.3.5.19.	SDMMC0 Clock Register (Default Value: 0x00000000) .....	80
4.3.5.20.	SDMMC1 Clock Register (Default Value: 0x00000000) .....	81
4.3.5.21.	SDMMC2 Clock Register (Default Value: 0x00000000) .....	82
4.3.5.22.	CE Clock Register (Default Value: 0x00000000) .....	83
4.3.5.23.	SPI0 Clock Register (Default Value: 0x00000000) .....	84
4.3.5.24.	USBPHY Configuration Register (Default Value: 0x00000000) .....	84
4.3.5.25.	DRAM Configuration Register (Default Value: 0x00000001).....	85
4.3.5.26.	PLL_DDR1 Configuration Register (Default Value: 0x00000030) .....	85
4.3.5.27.	MBUS Reset Register (Default Value: 0x80000000) .....	86
4.3.5.28.	DRAM Clock Gating Register (Default Value: 0x00000000).....	86
4.3.5.29.	DE Clock Gating Register (Default Value: 0x00000000) .....	87
4.3.5.30.	TCON Clock Register (Default Value: 0x00000000) .....	87
4.3.5.31.	CSI0 Clock Register (Default Value: 0x00000000) .....	88
4.3.5.32.	CSI1 Clock Register (Default Value: 0x00000000) .....	88
4.3.5.33.	VE Clock Register (Default Value: 0x00000000) .....	89
4.3.5.34.	AC Digital Clock Register (Default Value: 0x00000000).....	90
4.3.5.35.	AVS Clock Register (Default Value: 0x00000000) .....	90
4.3.5.36.	MBUS Clock Register (Default Value: 0x00000000) .....	90

4.3.5.37.	MIPI_CSI Register (Default Value: 0x00000000) .....	91
4.3.5.38.	PLL Stable Time Register0 (Default Value: 0x000000FF).....	91
4.3.5.39.	PLL Stable Time Register1 (Default Value: 0x000000FF).....	91
4.3.5.40.	PLL_CPUX Bias Register (Default Value: 0x08100200) .....	92
4.3.5.41.	PLL_AUDIO Bias Register (Default Value: 0x10100000) .....	92
4.3.5.42.	PLL_VIDEO Bias Register (Default Value: 0x10100000).....	93
4.3.5.43.	PLL_VE Bias Register (Default Value: 0x10100000).....	93
4.3.5.44.	PLL_DDR0 Bias Register (Default Value: 0x81104000).....	93
4.3.5.45.	PLL_PERIPH0 Bias Register (Default Value: 0x10100010) .....	94
4.3.5.46.	PLL_ISP Bias Register (Default Value: 0x10100000) .....	94
4.3.5.47.	PLL_PERIPH1 Bias Register (Default Value: 0x10100010) .....	95
4.3.5.48.	PLL_DDR1 Bias Register (Default Value: 0x10010000).....	95
4.3.5.49.	PLL_CPU Tuning Register (Default Value: 0x0A101000).....	95
4.3.5.50.	PLL_DDR0 Tuning Register (Default Value: 0x14880000).....	96
4.3.5.51.	PLL_CPU Pattern Control Register (Default Value: 0x00000000) .....	97
4.3.5.52.	PLL_AUDIO Pattern Control Register(Default Value: 0x00000000).....	97
4.3.5.53.	PLL_VIDEO Pattern Control Register (Default Value: 0x00000000).....	98
4.3.5.54.	PLL_VE Pattern Control Register (Default Value: 0x00000000).....	98
4.3.5.55.	PLL_DDR0 Pattern Control Register (Default Value: 0x00000000).....	99
4.3.5.56.	PLL_ISP Pattern Control Register (Default Value: 0x00000000) .....	99
4.3.5.57.	PLL_PERIPH1 Pattern Control Register (Default Value: 0x00000000) .....	100
4.3.5.58.	PLL_DDR1 Pattern Control Register (Default Value: 0x00000000).....	100
4.3.5.59.	PLL_DDR1 Pattern Control Register1 (Default Value: 0x00000000).....	101
4.3.5.60.	Bus Software Reset Register 0 (Default Value: 0x00000000).....	101



4.3.5.61.	Bus Software Reset Register 1 (Default Value: 0x00000000) .....	103
4.3.5.62.	Bus Software Reset Register 2 (Default Value: 0x00000000) .....	103
4.3.5.63.	Bus Software Reset Register 3 (Default Value: 0x00000000) .....	104
4.3.5.64.	Bus Software Reset Register 4 (Default Value: 0x00000000) .....	104
4.3.5.65.	PS Control Register (Default Value: 0x00000000) .....	104
4.3.5.66.	PS Counter Register (Default Value: 0x00000000) .....	105
4.3.6.	Programming Guidelines .....	106
4.3.6.1.	PLL .....	106
4.3.6.2.	BUS .....	106
4.3.6.3.	Clock Switch .....	106
4.3.6.4.	Gating and reset .....	106
4.4.	System Control .....	107
4.4.1.	Overview .....	107
4.4.2.	System Control Register List .....	107
4.4.3.	System Control Register Description .....	107
4.4.3.1.	Version Register (Default Value: 0x00000000) .....	107
4.4.3.2.	EMAC-EPHY Clock Register (Default Value: 0x00058000) .....	108
4.5.	Timer .....	110
4.5.1.	Overview .....	110
4.5.2.	Block Diagram .....	110
4.5.3.	Timer Register List .....	111
4.5.4.	Timer Register Description .....	111
4.5.4.1.	Timer IRQ Enable Register (Default Value: 0x00000000) .....	111
4.5.4.2.	Timer IRQ Status Register (Default Value: 0x00000000) .....	112

4.5.4.3.	Timer 0 Control Register (Default Value: 0x00000004).....	112
4.5.4.4.	Timer 0 Interval Value Register .....	113
4.5.4.5.	Timer 0 Current Value Register .....	114
4.5.4.6.	Timer 1 Control Register (Default Value: 0x00000004).....	114
4.5.4.7.	Timer 1 Interval Value Register .....	115
4.5.4.8.	Timer 1 Current Value Register .....	115
4.5.4.9.	Timer 2 Control Register .....	115
4.5.4.10.	Timer 2 Interval Value Register .....	116
4.5.4.11.	Timer 2 Current Value Register .....	117
4.5.4.12.	AVS Counter Control Register (Default Value: 0x00000000).....	117
4.5.4.13.	AVS Counter 0 Register (Default Value: 0x00000000).....	117
4.5.4.14.	AVS Counter 1 Register (Default Value: 0x00000000).....	118
4.5.4.15.	AVS Counter Divisor Register (Default Value: 0x05DB05DB).....	118
4.5.4.16.	Watchdog IRQ Enable Register (Default Value: 0x00000000) .....	119
4.5.4.17.	Watchdog Status Register (Default Value: 0x00000000).....	119
4.5.4.18.	Watchdog Control Register (Default Value: 0x00000000).....	119
4.5.4.19.	Watchdog Configuration Register (Default Value: 0x00000001).....	119
4.5.4.20.	Watchdog Mode Register (Default Value: 0x00000000).....	120
4.5.4.21.	64-bit Counter Control Register (Default Value: 0x00000000).....	120
4.5.4.22.	64-bit Counter Low Register (Default Value: 0x00000000).....	121
4.5.4.23.	64-bit Counter High Register (Default Value: 0x00000000).....	121
4.6.	High-speed Timer.....	122
4.6.1.	Overview .....	122
4.6.2.	Operation Principle .....	122

4.6.2.1.	HSTimer clock gating and software reset.....	122
4.6.2.2.	HSTimer reload bit .....	122
4.6.3.	HSTimer Register List .....	122
4.6.4.	HSTimer Register Description .....	123
4.6.4.1.	HS Timer IRQ Enable Register (Default Value: 0x00000000) .....	123
4.6.4.2.	HS Timer IRQ Status Register (Default Value: 0x00000000) .....	123
4.6.4.3.	HS Timer0 Control Register (Default Value: 0x00000000) .....	124
4.6.4.4.	HS Timer0 Interval Value Lo Register .....	125
4.6.4.5.	HS Timer0 Interval Value Hi Register .....	125
4.6.4.6.	HS Timer0 Current Value Lo Register .....	125
4.6.4.7.	HS Timer0 Current Value Hi Register .....	125
4.6.4.8.	HS Timer1 Control Register (Default Value: 0x00000000) .....	125
4.6.4.9.	HS Timer1 Interval Value Lo Register .....	126
4.6.4.10.	HS Timer1 Interval Value Hi Register .....	127
4.6.4.11.	HS Timer1 Current Value Lo Register .....	127
4.6.4.12.	HS Timer1 Current Value Hi Register .....	127
4.6.5.	Programming Guidelines .....	127
4.7.	PWM.....	129
4.7.1.	Overview .....	129
4.7.2.	Functionalities Description.....	129
4.7.3.	PWM Register List .....	129
4.7.4.	PWM Register Description .....	130
4.7.4.1.	PWM Control Register(Default Value: 0x00000000).....	130
4.7.4.2.	PWM Channel 0 Period Register .....	132

4.7.4.3.	PWM Channel 1 Period Register .....	133
4.8.	DMA .....	134
4.8.1.	Overview .....	134
4.8.2.	Functionalities Description.....	134
4.8.2.1.	Block Diagram .....	134
4.8.2.2.	DRQ Type and Corresponding Relation .....	135
4.8.2.3.	DMA Descriptor.....	135
4.8.3.	DMA Register List .....	136
4.8.4.	DMA Register Description .....	137
4.8.4.1.	DMA IRQ Enable Register0 (Default Value: 0x00000000) .....	137
4.8.4.2.	DMA IRQ Pending Status Register (Default Value: 0x00000000) .....	139
4.8.4.3.	DMA Auto Gating Register (Default Value: 0x00000000).....	140
4.8.4.4.	DMA Status Register (Default Value: 0x00000000).....	141
4.8.4.5.	DMA Channel Enable Register (Default Value: 0x00000000).....	142
4.8.4.6.	DMA Channel Pause Register (Default Value: 0x00000000) .....	142
4.8.4.7.	DMA Channel Descriptor Address Register(Default Value: 0x00000000) .....	142
4.8.4.8.	DMA Channel Configuration Register (Default Value: 0x00000000).....	143
4.8.4.9.	DMA Channel Current Source Address Register (Default Value: 0x00000000).....	144
4.8.4.10.	DMA Channel Current Destination Address Register (Default Value: 0x00000000) .....	144
4.8.4.11.	DMA Channel Byte Counter Left Register (Default Value: 0x00000000) .....	144
4.8.4.12.	DMA Channel Parameter Register (Default Value: 0x00000000).....	144
4.9.	GIC.....	146
4.9.1.	Interrupt Source .....	146
4.10.	Crypto Engine.....	150

4.10.1.	Overview .....	150
4.10.2.	Block Diagram .....	150
4.10.3.	Crypto Engine Register List.....	150
4.10.4.	Crypto Engine Register Description.....	151
4.10.4.1.	Control Register(Default Value: 0x00000000).....	151
4.10.4.2.	Key [n] Register (Default Value: 0x00000000) .....	153
4.10.4.3.	IV[n] Register(Default Value: 0x00000000).....	153
4.10.4.4.	Count [n] Register (Default Value: 0x00000000) .....	153
4.10.4.5.	FIFO Control/ Status Register (Default Value: 0x60000F0F) .....	153
4.10.4.6.	Interrupt Control/ Status Register (Default Value: 0x00000000).....	154
4.10.4.7.	Message Digest[n] Register (Default Value: 0x00000000).....	155
4.10.4.8.	CTS Length Register (Default Value: 0x00000000).....	155
4.10.4.9.	RXFIFO Register (Default Value: 0x00000000) .....	155
4.10.4.10.	TXFIFO Register (Default Value: 0x00000000).....	156
4.10.5.	Crypto Engine Clock Requirement.....	156
4.11.	LRADC.....	157
4.11.1.	Overview .....	157
4.11.2.	Clock Source .....	157
4.11.3.	Operation Principle .....	157
4.11.4.	LRADC Register List.....	158
4.11.5.	LRADC Register Description.....	159
4.11.5.1.	LRADC Control Register (Default Value: 0x01000168) .....	159
4.11.5.2.	LRADC Interrupt Control Register (Default Value: 0x00000000).....	160
4.11.5.3.	LRADC Interrupt Status Register (Default Value: 0x00000000).....	160

4.11.5.4.	LRADC Data0 Register (Default Value: 0x00000000).....	161
4.12.	RTC .....	162
4.12.1.	Overview .....	162
4.12.2.	RTC Register List .....	162
4.12.3.	RTC Register Description .....	163
4.12.3.1.	LOSC Control Register (Default Value: 0x00004000).....	163
4.12.3.2.	LOSC Auto Swith Status Register (Default Value: 0x00000000) .....	164
4.12.3.3.	RTC YY-MM-DD Register (Default Value: 0x00000000) .....	164
4.12.3.4.	RTC HH-MM-SS Register (Default Value: 0x00000000).....	165
4.12.3.5.	Alarm 0 Counter Register (Default Value: 0x00000000) .....	165
4.12.3.6.	Alarm 0 Current Value Register (Default Value: 0x00000000) .....	166
4.12.3.7.	Alarm 0 Enable Register (Default Value: 0x00000000) .....	166
4.12.3.8.	Alarm 0 IRQ Enable Register (Default Value: 0x00000000).....	166
4.12.3.9.	Alarm 0 IRQ Status Register (Default Value: 0x00000000).....	166
4.12.3.10.	Alarm 1 Week HH-MM-SS Register (Default Value: 0x00000000) .....	167
4.12.3.11.	Alarm 1 Enable Register (Default Value: 0x00000000) .....	167
4.12.3.12.	Alarm 1 IRQ Enable Register (Default Value: 0x00000000).....	168
4.12.3.13.	Alarm 1 IRQ Status Register (Default Value: 0x00000000).....	169
4.12.3.14.	Alarm Config Register (Default Value: 0x00000000).....	169
4.12.3.15.	LOSC Output Gating Register (Default Value: 0x00000000).....	169
4.12.3.16.	LOSC Output Gating Register (Default Value: 0x00000000).....	169
4.12.3.17.	VDD RTC Regulation Register (Default Value: 0x00000004).....	170
4.12.3.18.	IC Characteristic Register (Default Value: 0x00000000).....	170
4.13.	Audio Codec.....	171

4.13.1. Overview .....	171
4.13.2. Power and Signal Description.....	171
4.13.2.1. Analog I/O Pins.....	171
4.13.2.2. Filter/Reference .....	171
4.13.2.3. Power/Ground.....	172
4.13.3. Data Path Diagram .....	172
4.13.4. Audio Codec Register List .....	172
4.13.5. Audio Codec Register Description .....	176
4.13.5.1. 0x000 DAC Digital Part Control Register(Default Value: 0x00000000).....	176
4.13.5.2. 0x004 DAC FIFO Control Register(Default Value: 0x00000F00) .....	177
4.13.5.3. 0x008 DAC FIFO Status Register(Default Value: 0x00800088) .....	178
4.13.5.4. 0x010 ADC FIFO Control Register(Default Value: 0x00000F00) .....	179
4.13.5.5. 0x014 ADC FIFO Status Register(Default Value: 0x00000000) .....	181
4.13.5.6. 0x018 ADC RX DATA Register(Default Value: 0x00000000).....	181
4.13.5.7. 0x020 DAC TX DATA Register(Default Value: 0x00000000) .....	182
4.13.5.8. 0x040 DAC TX Counter Register(Default Value: 0x00000000) .....	182
4.13.5.9. 0x044 ADC RX Counter Register(Default Value: 0x00000000) .....	182
4.13.5.10. 0x048 DAC Debug Register(Default Value: 0x00000000).....	182
4.13.5.11. 0x04C ADC Debug Register(Default Value: 0x00000000).....	183
4.13.5.12. 0x050 HMIC Control Register(Default Value: 0x00000000) .....	183
4.13.5.13. 0x054 HMIC Data Register(Default Value: 0x00000000).....	185
4.13.5.14. 0x060 DAC DAP Control Register(Default Value: 0x00000000).....	185
4.13.5.15. 0x070 ADC DAP Control Register(Default Value: 0x00000000).....	186
4.13.5.16. 0x074 ADC DAP Left Control Register(Default Value: 0x001F1800).....	187

4.13.5.17.	0x078 ADC DAP Right Control Register(Default Value: 0x001F7000).....	188
4.13.5.18.	0x07CADC DAP Parameter Register(Default Value: 0x2C2C2828) .....	189
4.13.5.19.	0x080 ADC DAP Left Average Coef Register(Default Value: 0x00051EB8) .....	190
4.13.5.20.	0x084 ADC DAP Left Decay & Attack Time Register(Default Value: 0x0000001F) .....	190
4.13.5.21.	0x088 ADC DAP Right Average Coef Register(Default Value: 0x00051EB8) .....	190
4.13.5.22.	0x08C ADC DAP Right Decay & Attack Time Register(Default Value: 0x0000001F).....	191
4.13.5.23.	0x090 ADC DAP HPF Coef Register(Default Value: 0x00FFAC1) .....	191
4.13.5.24.	0x094 ADC DAP Left Input Signal Low Average Coef Register(Default Value: 0x00051EB8) .	191
4.13.5.25.	0x098 ADC DAP Right Input Signal Low Average Coef Register(Default Value: 0x00051EB8) 192	
4.13.5.26.	0x09C ADC DAP Optimum Register(Default Value: 0x00000000) .....	192
4.13.5.27.	0x100 DAC DRC High HPF Coef Register(Default Value: 0x000000FF) .....	193
4.13.5.28.	0x104 DAC DRC Low HPF Coef Register(Default Value: 0x0000FAC1).....	193
4.13.5.29.	0x108 DAC DRC Control Register(Default Value: 0x00000080).....	193
4.13.5.30.	0x10C DAC DRC Left Peak Filter High Attack Time Coef Register(Default Value: 0x0000000B) 194	
4.13.5.31.	0x110 DAC DRC Left Peak Filter Low Attack Time Coef Register(Default Value: 0x000077BF) 195	
4.13.5.32.	0x114 DAC DRC Right Peak Filter High Attack Time Coef Register(Default Value: 0x0000000B) 195	
4.13.5.33.	0x118 DAC DRC Peak Filter Low Attack Time Coef Register(Default Value: 0x000077BF)....	195
4.13.5.34.	0x11C DAC DRC Left Peak Filter High Release Time Coef Register(Default Value: 0x000000FF) 195	
4.13.5.35.	0x120 DAC DRC Left Peak Filter Low Release Time Coef Register(Default Value: 0x0000E1F8) 195	
4.13.5.36.	0x124 DAC DRC Right Peak filter High Release Time Coef Register(Default Value: 0x000000FF) 196	
4.13.5.37.	0x128 DAC DRC Right Peak filter Low Release Time Coef Register(Default Value: 0x0000E1F8)	



	196
4.13.5.38.	0x12C DAC DRC Left RMS Filter High Coef Register(Default Value: 0x00000001) .....196
4.13.5.39.	0x130 DAC DRC Left RMS Filter Low Coef Register(Default Value: 0x00002BAF).....196
4.13.5.40.	0x134 DAC DRC Right RMS Filter High Coef Register(Default Value: 0x00000001) .....196
4.13.5.41.	0x138 DAC DRC Right RMS Filter Low Coef Register(Default Value: 0x00002BAF).....197
4.13.5.42.	0x13C DAC DRC Compressor Theshold High Setting Register(Default Value: 0x000006A4).197
4.13.5.43.	0x140 DAC DRC Compressor Slope High Setting Register(Default Value: 0x0000D3C0) .....197
4.13.5.44.	0x144 DAC DRC Compressor Slope High Setting Register(Default Value: 0x00000080).....197
4.13.5.45.	0x148 DAC DRC Compressor Slope Low Setting Register(Default Value: 0x00000000).....197
4.13.5.46.	0x14C DAC DRC Compressor High Output at Compressor Threshold Register(Default Value: 0x0000F95B) .....198
4.13.5.47.	0x150 DAC DRC Compressor Low Output at Compressor Threshold Register(Default Value: 0x00002C3F).....198
4.13.5.48.	0x154 DAC DRC Limiter Theshold High Setting Register(Default Value: 0x000001A9).....198
4.13.5.49.	0x158 DAC DRC Limiter Theshold Low Setting Register(Default Value: 0x000034F0) .....198
4.13.5.50.	0x15C DAC DRC Limiter Slope High Setting Register(Default Value: 0x00000005).....198
4.13.5.51.	0x160 DAC DRC Limiter Slope Low Setting Register(Default Value: 0x1EB8).....199
4.13.5.52.	0x164 DAC DRC Limiter High Output at Limiter Threshold(Default Value: 0x0000FBD8).....199
4.13.5.53.	0x168 DAC DRC Limiter Low Output at Limiter Threshold(Default Value: 0x0000FBA7).....199
4.13.5.54.	0x16C DAC DRC Expander Theshold High Setting Register(Default Value: 0x00000BA0).....199
4.13.5.55.	0x170 DAC DRC Expander Theshold Low Setting Register(Default Value: 0x00007291) .....199
4.13.5.56.	0x174 DAC DRC Expander Slope High Setting Register(Default Value: 0x00000500) .....199
4.13.5.57.	0x178 DAC DRC Expander Slope Low Setting Register(Default Value: 0x00000000).....200
4.13.5.58.	0x17C DAC DRC Expander High Output at Expander Threshold(Default Value: 0xF45F) .....200
4.13.5.59.	0x180 DAC DRC Expander Low Output at Expander Threshold(Default Value: 0x00008D6E)
	200

4.13.5.60.	0x184 DAC DRC Linear Slope High Setting Register(Default Value: 0x00000100) .....	200
4.13.5.61.	0x188 DAC DRC Linear Slope Low Setting Register(Default Value: 0x00000000) .....	201
4.13.5.62.	0x18C DAC DRC Smooth filter Gain High Attack Time Coef Register(Default Value: 0x00000002) .....	201
4.13.5.63.	0x190 DAC DRC Smooth filter Gain Low Attack Time Coef Register(Default Value: 0x00005600) .....	201
4.13.5.64.	0x194 DAC DRC Smooth filter Gain High Release Time Coef Register(Default Value: 0x00000000) .....	201
4.13.5.65.	0x198 DAC DRC Smooth filter Gain Low Release Time Coef Register(Default Value: 0x00000F04).....	201
4.13.5.66.	0x19C DAC DRC MAX Gain High Setting Register(Default Value: 0x0000FE56) .....	202
4.13.5.67.	0x1A0 DAC DRC MAX Gain Low Setting Register(Default Value: 0x0000CB0F).....	202
4.13.5.68.	0x1A4 DAC DRC MIN Gain High Setting Register(Default Value: 0x0000_F95B).....	202
4.13.5.69.	0x1A8 DAC DRC MIN Gain Low Setting Register(Default Value: 0x00002C3F).....	202
4.13.5.70.	0x1AC DAC DRC Expander Smooth Time High Coef Register(Default Value: 0x00000000) ..	202
4.13.5.71.	0x1B0 DAC DRC Expander Smooth Time Low Coef Register(Default Value: 0x0000640C) ...	203
4.13.5.72.	0x1B8 DAC DRC HPF Gain High Coef Register(Default Value: 0x00000100) .....	203
4.13.5.73.	0x1BC DAC DRC HPF Gain Low Coef Register(Default Value: 0x00000000) .....	203
4.13.5.74.	0x200 ADC DRC High HPF Coef Register(Default Value: 0x000000FF) .....	203
4.13.5.75.	0x204 ADC DRC Low HPF Coef Register(Default Value: 0x0000FAC1).....	203
4.13.5.76.	0x208 ADC DRC Control Register(Default Value: 0x00000080).....	203
4.13.5.77.	0x20C ADC DRC Left Peak Filter High Attack Time Coef Register(Default Value: 0x0000000B) 205	
4.13.5.78.	0x210 ADC DRC Left Peak Filter Low Attack Time Coef Register(Default Value: 0x000077BF) 205	
4.13.5.79.	0x214 ADC DRC Right Peak Filter High Attack Time Coef Register(Default Value: 0x0000000B) 205	
4.13.5.80.	0x218 ADC DRC Peak Filter Low Attack Time Coef Register(Default Value: 0x000077BF)....	205

4.13.5.81.	0x21C ADC DRC Left Peak Filter High Release Time Coef Register(Default Value: 0x000000FF) 206	
4.13.5.82.	0x220 ADC DRC Left Peak Filter Low Release Time Coef Register(Default Value: 0x0000E1F8) 206	
4.13.5.83.	0x224 ADC DRC Right Peak filter High Release Time Coef Register(Default Value: 0x000000FF) 206	
4.13.5.84.	0x228 ADC DRC Right Peak filter Low Release Time Coef Register(Default Value: 0x0000E1F8) 206	
4.13.5.85.	0x22C ADC DRC Left RMS Filter High Coef Register(Default Value: 0x00000001) .....	206
4.13.5.86.	0x230 ADC DRC Left RMS Filter Low Coef Register(Default Value: 0x00002BAF).....	207
4.13.5.87.	0x234 ADC DRC Right RMS Filter High Coef Register(Default Value: 0x00000001) .....	207
4.13.5.88.	0x238 ADC DRC Right RMS Filter Low Coef Register(Default Value: 0x00002BAF).....	207
4.13.5.89.	0x23C ADC DRC Compressor Theshold High Setting Register(Default Value: 0x000006A4)	207
4.13.5.90.	0x240 ADC DRC Compressor Slope High Setting Register(Default Value: 0x0000D3C0) .....	207
4.13.5.91.	0x244 ADC DRC Compressor Slope High Setting Register(Default Value: 0x00000080).....	208
4.13.5.92.	0x248 ADC DRC Compressor Slope Low Setting Register(Default Value: 0x00000000) .....	208
4.13.5.93.	0x24C ADC DRC Compressor High Output at Compressor Threshold Register(Default Value: 0x0000F95B) .....	208
4.13.5.94.	0x250 ADC DRC Compressor Low Output at Compressor Threshold Register(Default Value: 0x00002C3F).....	208
4.13.5.95.	0x254 ADC DRC Limiter Theshold High Setting Register(Default Value: 0x000001A9).....	208
4.13.5.96.	0x258 ADC DRC Limiter Theshold Low Setting Register(Default Value: 0x000034F0).....	209
4.13.5.97.	0x25C ADC DRC Limiter Slope High Setting Register(Default Value: 0x00000005).....	209
4.13.5.98.	0x260 ADC DRC Limiter Slope Low Setting Register(Default Value: 0x1EB8).....	209
4.13.5.99.	0x264 ADC DRC Limiter High Output at Limiter Threshold(Default Value: 0x0000FBD8).....	209
4.13.5.100.	0x268 ADC DRC Limiter Low Output at Limiter Threshold(Default Value: 0x0000FBA7)....	209
4.13.5.101.	0x26C ADC DRC Expander Theshold High Setting Register(Default Value: 0x00000BA0)...	210

4.13.5.102.	0x270 ADC DRC Expander Theshold Low Setting Register(Default Value: 0x00007291) ....	210
4.13.5.103.	0x274 ADC DRC Expander Slope High Setting Register(Default Value: 0x00000500) .....	210
4.13.5.104.	0x278 ADC DRC Expander Slope Low Setting Register(Default Value: 0x00000000) .....	210
4.13.5.105.	0x27C ADC DRC Expander High Output at Expander Threshold(Default Value: 0xF45F) ...	210
4.13.5.106.	0x280 ADC DRC Expander Low Output at Expander Threshold(Default Value: 0x00008D6E) 211	
4.13.5.107.	0x284 ADC DRC Linear Slope High Setting Register(Default Value: 0x00000100) .....	211
4.13.5.108.	0x288 ADC DRC Linear Slope Low Setting Register(Default Value: 0x00000000) .....	211
4.13.5.109.	0x28C ADC DRC Smooth filter Gain High Attack Time Coef Register(Default Value: 0x00000002) 211	
4.13.5.110.	0x290 ADC DRC Smooth filter Gain Low Attack Time Coef Register(Default Value: 0x00005600) 211	
4.13.5.111.	0x294 ADC DRC Smooth filter Gain High Release Time Coef Register(Default Value: 0x00000000) 212	
4.13.5.112.	0x298 ADC DRC Smooth filter Gain Low Release Time Coef Register(Default Value: 0x00000F04) 212	
4.13.5.113.	0x29C ADC DRC MAX Gain High Setting Register(Default Value: 0x0000FE56) .....	212
4.13.5.114.	0x2A0 ADC DRC MAX Gain Low Setting Register(Default Value: 0x0000CB0F) .....	212
4.13.5.115.	0x2A4 ADC DRC MIN Gain High Setting Register(Default Value: 0x0000F95B) .....	212
4.13.5.116.	0x2A8 ADC DRC MIN Gain Low Setting Register(Default Value: 0x00002C3F) .....	213
4.13.5.117.	0x2AC ADC DAP Expander Smooth Time High Coef Register(Default Value: 0x00000000)	213
4.13.5.118.	0x2B0 ADC DRC Expander Smooth Time Low Coef Register (Default Value: 0x0000640C)	213
4.13.5.119.	0x2B8 ADC DRC HPF Gain High(Default Value: 0x00000100) .....	213
4.13.5.120.	0x2BC ADC DRC HPF Gain Low(Default Value: 0x00000000) .....	213
4.13.5.121.	AC Parameter Configuration Register(Default Value: 0x10000000) .....	214
4.13.5.122.	0x00 Headphone Volume Control(Default Value: 0x00) .....	214
4.13.5.123.	0x01 Left Output Mixer Source Select Control Register(Default Value: 0x00) .....	215

4.13.5.124.	0x02 Right Output Mixer Source Select Control Register(Default Value: 0x00).....	215
4.13.5.125.	0x03 DAC Analog Enable and PA Source Control Register(Default Value: 0x00).....	215
4.13.5.126.	0x06 MIC1 Gain Control Register(Default Value: 0x33) .....	216
4.13.5.127.	0x07 PA Enable and HP Control Register(Default Value: 0x14) .....	217
4.13.5.128.	0x0B BIAS and MIC1 boost(Default Value: 0x04) .....	217
4.13.5.129.	0x0C Left ADC Mixer Mute Control(Default Value: 0x00) .....	218
4.13.5.130.	0x0D Right ADC Mixer Mute Control(Default Value: 0x00).....	218
4.13.5.131.	0x0E PA Anti-pop time Control(Default Value: 0x04) .....	218
4.13.5.132.	0x0F ADC Analog Control Register(Default Value: 0x03).....	219
4.13.5.133.	0x10 OPDRV/OPCOM/OPADC Control(Default Value: 0x55).....	219
4.13.5.134.	0x11 OPMIC、OPVR and OPADC Control(Default Value: 0x55).....	219
4.13.5.135.	0x12 ZERO CROSS Control(Default Value: 0x42) .....	220
4.13.5.136.	0x13 ADC Function Control(Default Value: 0xD6).....	220
4.13.5.137.	0x14 Bias & DA16 Calibration Control Register(Default Value: 0x00) .....	221
4.13.5.138.	0x15 DA16 Calibration Data(Default Value: 0x80) .....	221
4.13.5.139.	0x17 Bias Calibration Data(Default Value: 0x20).....	222
4.13.5.140.	0x18 Bias Register Setting Data(Default Value: 0x20) .....	222
4.14.	Port Controller.....	223
4.14.1.	Port Controller Register List .....	223
4.14.2.	Port Controller Register Description .....	224
4.14.2.1.	PB Configure Register 0 (Default Value: 0x77777777) .....	224
4.14.2.2.	PB Configure Register 1 (Default Value: 0x00777777) .....	225
4.14.2.3.	PB Configure Register 2 (Default Value: 0x00000000) .....	225
4.14.2.4.	PB Configure Register 3 (Default Value: 0x00000000) .....	226

4.14.2.5.	PB Data Register (Default Value: 0x00000000) .....	226
4.14.2.6.	PB Multi-Driving Register 0 (Default Value: 0x05555555) .....	226
4.14.2.7.	PB Multi-Driving Register 1 (Default Value: 0x00000000) .....	226
4.14.2.8.	PB PULL Register 0 (Default Value: 0x00000000).....	226
4.14.2.9.	PB PULL Register 1 (Default Value: 0x00000000).....	227
4.14.2.10.	PC Configure Register 0 (Default Value: 0x77777777) .....	227
4.14.2.11.	PC Configure Register 1 (Default Value: 0x00000777) .....	228
4.14.2.12.	PC Configure Register 2 (Default Value: 0x00000000) .....	228
4.14.2.13.	PC Configure Register 3 (Default Value: 0x00000000) .....	228
4.14.2.14.	PC Data Register (Default Value: 0x00000000) .....	228
4.14.2.15.	PC Multi-Driving Register 0 (Default Value: 0x00155555) .....	229
4.14.2.16.	PC Multi-Driving Register 1 (Default Value: 0x00000000) .....	229
4.14.2.17.	PC PULL Register 0 (Default Value: 0x00000000).....	229
4.14.2.18.	PC PULL Register 1 (Default Value: 0x00000000).....	229
4.14.2.19.	PE Configure Register 0 (Default Value: 0x77777777) .....	229
4.14.2.20.	PE Configure Register 1 (Default Value: 0x77777777) .....	231
4.14.2.21.	PE Configure Register 2 (Default Value: 0x77777777) .....	232
4.14.2.22.	PE Configure Register 3 (Default Value: 0x00000007) .....	233
4.14.2.23.	PE Data Register (Default Value: 0x00000000) .....	233
4.14.2.24.	PE Multi-Driving Register 0 (Default Value: 0x55555555).....	234
4.14.2.25.	PE Multi-Driving Register 1 (Default Value: 0x00015555).....	234
4.14.2.26.	PE PULL Register 0 (Default Value: 0x00000000) .....	234
4.14.2.27.	PE PULL Register 1 (Default Value: 0x00000000) .....	234
4.14.2.28.	PF Configure Register 0 (Default Value: 0x07373733) .....	235

4.14.2.29.	PF Configure Register 1 (Default Value: 0x00000000) .....	236
4.14.2.30.	PF Configure Register 2(Default Value: 0x00000000) .....	236
4.14.2.31.	PF Configure Register 3(Default Value: 0x00000000) .....	236
4.14.2.32.	PF Data Register (Default Value: 0x00000000).....	236
4.14.2.33.	PF Multi-Driving Register 0 (Default Value: 0x00001555).....	236
4.14.2.34.	PF Multi-Driving Register 1 (Default Value: 0x00000000).....	237
4.14.2.35.	PF PULL Register 0 (Default Value: 0x00000000) .....	237
4.14.2.36.	PF PULL Register 1 (Default Value: 0x00000000) .....	237
4.14.2.37.	PG Configure Register 0 (Default Value: 0x77777777).....	237
4.14.2.38.	PG Configure Register 1 (Default Value: 0x00777777).....	238
4.14.2.39.	PG Configure Register 2 (Default Value: 0x00000000).....	238
4.14.2.40.	PG Configure Register 3 (Default Value: 0x00000000).....	239
4.14.2.41.	PG Data Register (Default Value: 0x00000000).....	239
4.14.2.42.	PG Multi-Driving Register 0 (Default Value: 0x05555555) .....	239
4.14.2.43.	PG Multi-Driving Register 1 (Default Value: 0x00000000) .....	239
4.14.2.44.	PG PULL Register 0 (Default Value: 0x00000000) .....	239
4.14.2.45.	PG PULL Register 1 (Default Value: 0x00000000) .....	240
4.14.2.46.	PB External Interrupt Configure Register 0 (Default Value: 0x00000000) .....	240
4.14.2.47.	PB External Interrupt Configure Register 1 (Default Value: 0x00000000) .....	240
4.14.2.48.	PB External Interrupt Configure Register 2 (Default Value: 0x00000000) .....	241
4.14.2.49.	PB External Interrupt Configure Register 3 (Default Value: 0x00000000) .....	241
4.14.2.50.	PB External Interrupt Control Register (Default Value: 0x00000000) .....	241
4.14.2.51.	PB External Interrupt Status Register (Default Value: 0x00000000) .....	241
4.14.2.52.	PB External Interrupt Debounce Register (Default Value: 0x00000000).....	241

4.14.2.53.	PG External Interrupt Configure Register 0 (Default Value: 0x00000000) .....	242
4.14.2.54.	PG External Interrupt Configure Register 1 (Default Value: 0x00000000) .....	242
4.14.2.55.	PG External Interrupt Configure Register 2 (Default Value: 0x00000000) .....	242
4.14.2.56.	PG External Interrupt Configure Register 3 (Default Value: 0x00000000) .....	242
4.14.2.57.	PG External Interrupt Control Register (Default Value: 0x00000000).....	243
4.14.2.58.	PG External Interrupt Status Register (Default Value: 0x00000000).....	243
4.14.2.59.	PG External Interrupt Debounce Register (Default Value: 0x00000000) .....	243
Chapter 5	Memory.....	244
5.1.	SD/MMC.....	244
5.1.1.	Overview .....	244
5.1.2.	Block Diagram .....	245
5.1.3.	SD/MMC Controller Timing Diagram .....	245
5.1.4.	SD/MMC Controller Special Requirement.....	245
5.1.4.1.	SD/MMC Pin List .....	245
5.1.5.	Internal DMA Controller Description .....	246
5.1.5.1.	IDMAC Descriptor Structure.....	246
5.1.5.2.	DES0 definition.....	247
5.1.5.3.	DES1 definition.....	248
5.1.5.4.	DES2 definition.....	248
5.1.5.5.	DES3 definition.....	248
5.1.6.	SD/MMC Register List.....	248
5.1.7.	SD/MMC Register Description.....	249
5.1.7.1.	SD Global Control Register(Default Value: 0x00000300) .....	249
5.1.7.2.	SD Clock Control Register(Default Value: 0x00000000).....	250



5.1.7.3.	SD Timeout Register (Default Value: 0xFFFFF40).....	251
5.1.7.4.	SD Bus Width Register (Default Value: 0x00000000) .....	251
5.1.7.5.	SD Block Size Register (Default Value: 0x00000200).....	251
5.1.7.6.	SD Block Count Register (Default Value: 0x00000200) .....	252
5.1.7.7.	SD Command Register (Default Value: 0x00000000).....	252
5.1.7.8.	SD Command Argument Register (Default Value: 0x00000000).....	254
5.1.7.9.	SD Response 0 Register (Default Value: 0x00000000) .....	254
5.1.7.10.	SD Response 1 Register (Default Value: 0x00000000) .....	254
5.1.7.11.	SD Response 2 Register (Default Value: 0x00000000) .....	254
5.1.7.12.	SD Response 3 Register (Default Value: 0x00000000) .....	255
5.1.7.13.	SD Interrupt Mask Register (Default Value: 0x00000000) .....	255
5.1.7.14.	SD Masked Interrupt Status Register (Default Value: 0x00000000) .....	255
5.1.7.15.	SD Raw Interrupt Status Register (Default Value: 0x00000000) .....	256
5.1.7.16.	SD Status Register (Default Value: 0x00000006) .....	257
5.1.7.17.	SD FIFO Water Level Register (Default Value: 0x000F0000) .....	258
5.1.7.18.	SD Function Select Register (Default Value: 0x00000000).....	259
5.1.7.19.	SD Auto Command 12 Register (Default Value: 0x0000ffff) .....	260
5.1.7.20.	SD NewTiming Set Register (Default Value: 0x00000001,only used in SDC2) .....	260
5.1.7.21.	SD Hardware Reset Register (Default Value: 0x00000001).....	261
5.1.7.22.	SD DMAC Control Register (Default Value: 0x00000000) .....	261
5.1.7.23.	SD Descriptor List Base Address Register (Default Value: 0x00000000) .....	262
5.1.7.24.	SD DMAC Status Register (Default Value: 0x0000_0000) .....	262
5.1.7.25.	SD DMAC Interrupt Enable Register (Default Value: 0x00000000).....	264
5.1.7.26.	Card Threshold Control Register (Default Value: 0x00000000) .....	265

5.1.7.27.	eMMC4.41 DDR Start Bit Detection Control Register (Default Value: 0x00000000) .....	265
5.1.7.28.	SD Response CRC Register (Default Value: 0x00000000).....	266
5.1.7.29.	SD Data7 CRC Register (Default Value: 0x00000000).....	266
5.1.7.30.	SD Data6 CRC Register (Default Value: 0x00000000).....	266
5.1.7.31.	SD Data5 CRC Register (Default Value: 0x00000000).....	266
5.1.7.32.	SD Data4 CRC Register (Default Value: 0x00000000).....	267
5.1.7.33.	SD Data3 CRC Register (Default Value: 0x00000000).....	267
5.1.7.34.	SD Data2 CRC Register (Default Value: 0x00000000).....	267
5.1.7.35.	SD Data1 CRC Register (Default Value: 0x00000000).....	267
5.1.7.36.	SD Data0 CRC Register (Default Value: 0x00000000).....	268
5.1.7.37.	SD CRC Status Register (Default Value: 0x00000000) .....	268
5.1.7.38.	SD FIFO Register (Default Value: 0x00000000) .....	268
Chapter 6	Image.....	269
6.1.	CSI.....	269
6.1.1.	Overview .....	269
6.1.2.	Functionalities Description.....	270
6.1.2.1.	Block Diagram .....	270
6.1.2.2.	CSI FIFO Distribution .....	271
6.1.2.3.	Pin Mapping .....	271
6.1.2.4.	Timing.....	272
6.1.2.5.	Bit Definition .....	273
6.1.3.	CSI Register list .....	274
6.1.4.	CSI Register Description .....	275
6.1.4.1.	CSI Enable Register (Default Value: 0x00000000).....	275

6.1.4.2.	CSI Interface Configuration Register (Default Value: 0x00000000) .....	276
6.1.4.3.	CSI Capture Register (Default Value: 0x00000000).....	277
6.1.4.4.	CSI Synchronization Counter Register (Default Value: 0x00000000) .....	278
6.1.4.5.	CSI FIFO Threshold Register (Default Value: 0x040f0400) .....	278
6.1.4.6.	CSI BT656 Header Configuration Register (Default Value: 0x03020100).....	279
6.1.4.7.	CSI Pattern Generation Length Register (Default Value: 0x00000000).....	279
6.1.4.8.	CSI Pattern Generation Address Register (Default Value: 0x00000000).....	279
6.1.4.9.	CSI Version Register (Default Value: 0x00000000) .....	280
6.1.4.10.	CSI Channel_0 configuration Register (Default Value: 0x00300200).....	280
6.1.4.11.	CSI Channel_0 scale Register (Default Value: 0x00000000) .....	282
6.1.4.12.	CSI Channel_0 FIFO 0 output buffer-A address Register (Default Value: 0x00000000).....	282
6.1.4.13.	CSI Channel_0 FIFO 1 output buffer-A address Register (Default Value: 0x00000000).....	283
6.1.4.14.	CSI Channel_0 FIFO 2 output buffer-A address Register (Default Value: 0x00000000).....	283
6.1.4.15.	CSI Channel_0 status Register (Default Value: 0x00000000).....	283
6.1.4.16.	CSI Channel_0 interrupt enable Register (Default Value: 0x00000000) .....	283
6.1.4.17.	CSI Channel_0 interrupt status Register (Default Value: 0x00000000) .....	284
6.1.4.18.	CSI Channel_0 filed1 vertical size Register (Default Value: 0x01E00000).....	285
6.1.4.19.	CSI Channel_0 horizontal size Register (Default Value: 0x05000000) .....	285
6.1.4.20.	CSI Channel_0 vertical size Register (Default Value: 0x01E00000).....	286
6.1.4.21.	CSI Channel_0 buffer length Register (Default Value: 0x01400280) .....	286
6.1.4.22.	CSI Channel_0 flip size Register (Default Value: 0x01E00280).....	286
6.1.4.23.	CSI Channel_0 frame clock counter Register (Default Value: 0x00000000) .....	286
6.1.4.24.	CSI Channel_0 accumulated and internal clock counter Register (Default Value: 0x00000000)	287
6.1.4.25.	CSI Channel_0 FIFO Statistic Register (Default Value: 0x00000000).....	287

6.1.4.26.	CSI Channel_0 PCLK Statistic Register (Default Value: 0x00007FFF) .....	287
6.1.4.27.	CCI Control Register (Default Value: 0x00000000) .....	288
6.1.4.28.	CCI Transmission Configuration Register (Default Value: 0x10000000) .....	289
6.1.4.29.	CCI Packet Format Register (Default Value: 0x00110001) .....	290
6.1.4.30.	CCI Bus Control Register (Default Value: 0x00002500) .....	290
6.1.4.31.	CCI Interrupt Control Register (Default Value: 0x00000000).....	291
6.1.4.32.	CCI Line Counter Trigger Control Register (Default Value: 0x00000000).....	291
6.1.4.33.	CCI FIFO Access Register (Default Value: 0x00000000) .....	291
6.2.	MIPI CSI2 .....	292
6.2.1.	Overview .....	292
Chapter 7	Display .....	293
7.1.	Display Engine 2.0 .....	293
7.1.1.	Overview .....	293
7.2.	TCON .....	294
7.2.1.	Overview .....	294
7.2.2.	Block Diagram .....	294
7.2.3.	Functionalities Description.....	295
7.2.3.1.	Panel Interface .....	295
7.2.3.2.	RGB gamma correction .....	298
7.2.3.3.	CEU module.....	298
7.2.3.4.	CMAP module .....	298
7.2.4.	TCON Module Register List.....	299
7.2.5.	TCON Module Register Description .....	300
7.2.5.1.	TCON_GCTL_REG (Default Value: 0x00000000).....	300

7.2.5.2.	TCON_GINT0_REG (Default Value: 0x00000000) .....	300
7.2.5.3.	TCON_GINT1_REG (Default Value: 0x00000000) .....	301
7.2.5.4.	TCON0_TRM_CTL_REG (Default Value: 0x00000000) .....	302
7.2.5.5.	TCON0_FRM_SEED_REG (Default Value: 0x00000000) .....	302
7.2.5.6.	TCON0_FRM_TAB_REG (Default Value: 0x00000000) .....	302
7.2.5.7.	TCON0_CTL_REG (Default Value: 0x00000000) .....	303
7.2.5.8.	TCON0_DCLK_REG (Default Value: 0x00000000) .....	304
7.2.5.9.	TCON0_BASIC0_REG (Default Value: 0x00000000) .....	304
7.2.5.10.	TCON0_BASIC1_REG (Default Value: 0x00000000) .....	304
7.2.5.11.	TCON0_BASIC2_REG (Default Value: 0x00000000) .....	305
7.2.5.12.	TCON0_BASIC3_REG (Default Value: 0x00000000) .....	305
7.2.5.13.	TCON0_HV_IF_REG (Default Value: 0x00000000) .....	305
7.2.5.14.	TCON0_CPU_IF_REG (Default Value: 0x00000000) .....	306
7.2.5.15.	TCON0_CPU_WR_REG (Default Value: 0x00000000) .....	307
7.2.5.16.	TCON0_CPU_RD0_REG (Default Value: 0x00000000) .....	308
7.2.5.17.	TCON0_CPU_RD1_REG (Default Value: 0x00000000) .....	308
7.2.5.18.	TCON0_IO_POL_REG (Default Value: 0x00000000) .....	308
7.2.5.19.	TCON0_IO_TRI_REG (Default Value: 0x0FFFFFFF) .....	309
7.2.5.20.	TCON_ECC_FIFO_REG (Default Value: 0x00000000) .....	309
7.2.5.21.	TCON_DEBUG_REG (Default Value: 0x00000000) .....	310
7.2.5.22.	TCON_CEU_CTL_REG (Default Value: 0x00000000) .....	310
7.2.5.23.	TCON_CEU_COEF_MUL_REG (Default Value: 0x00000000) .....	311
7.2.5.24.	TCON_CEU_COEF_ADD_REG (Default Value: 0x00000000) .....	311
7.2.5.25.	TCON_CEU_COEF_RANG_REG (Default Value: 0x00000000) .....	311

7.2.5.26.	TCON0_CPU_TRIO_REG (Default Value: 0x00000000).....	312
7.2.5.27.	TCON0_CPU_TRI1_REG (Default Value: 0x00000000).....	312
7.2.5.28.	TCON0_CPU_TRI2_REG (Default Value: 0x00200000).....	312
7.2.5.29.	TCON0_CPU_TRI3_REG (Default Value: 0x00000000).....	312
7.2.5.30.	TCON_CMAP_CTL_REG (Default Value: 0x00000000).....	313
7.2.5.31.	TCON_CMAP_ODD0_REG (Default Value: 0x00000000).....	313
7.2.5.32.	TCON_CMAP_ODD1_REG (Default Value: 0x00000000).....	314
7.2.5.33.	TCON_CMAP_EVEN0_REG (Default Value: 0x00000000).....	314
7.2.5.34.	TCON_CMAP_EVEN1_REG (Default Value: 0x00000000).....	314
7.2.5.35.	TCON_SAFE_PERIOD_REG (Default Value: 0x00000000).....	314
<b>Chapter 8</b>	<b>Interfaces.....</b>	<b>316</b>
8.1.	TWI.....	317
8.1.1.	Overview.....	317
8.1.2.	Timing Diagram.....	317
8.1.3.	TWI Controller Special Requirement.....	318
8.1.3.1.	TWI Pin List.....	318
8.1.3.2.	TWI Controller Operation.....	318
8.1.4.	TWI Controller Register List.....	318
8.1.5.	TWI Controller Register Description.....	319
8.1.5.1.	TWI Slave Address Register(Default Value: 0x00000000).....	319
8.1.5.2.	TWI Extend Address Register(Default Value: 0x00000000).....	320
8.1.5.3.	TWI Data Register(Default Value: 0x00000000).....	320
8.1.5.4.	TWI Control Register(Default Value: 0x00000000).....	320
8.1.5.5.	TWI Status Register(Default Value: 0x000000F8).....	321

8.1.5.6.	TWI Clock Register(Default Value: 0x00000000) .....	322
8.1.5.7.	TWI Soft Reset Register(Default Value: 0x00000000).....	323
8.1.5.8.	TWI Enhance Feature Register(Default Value: 0x00000000).....	323
8.1.5.9.	TWI Line Control Register(Default Value: 0x0000003A) .....	323
8.1.5.10.	TWI DVFS Control Register(Default Value: 0x00000000).....	324
8.2.	SPI.....	326
8.2.1.	Overview .....	326
8.2.2.	SPI Timing Diagram .....	326
8.2.3.	SPI Special Requirement.....	327
8.2.3.1.	SPI Pin List .....	327
8.2.3.2.	SPI Module Clock Source and Frequency.....	328
8.2.4.	SPI Register List .....	328
8.2.5.	SPI Register Description .....	329
8.2.5.1.	SPI Global Control Register(Default Value: 0x00000080) .....	329
8.2.5.2.	SPI Transfer Control Register(Default Value: 0x00000087).....	329
8.2.5.3.	SPI Interrupt Control Register(Default Value: 0x00000000) .....	331
8.2.5.4.	SPI Interrupt Status Register(Default Value: 0x00000022) .....	333
8.2.5.5.	SPI FIFO Control Register(Default Value: 0x00400001).....	334
8.2.5.6.	SPI FIFO Status Register(Default Value: 0x00000000) .....	336
8.2.5.7.	SPI Wait Clock Register(Default Value: 0x0000_0000).....	336
8.2.5.8.	SPI Clock Control Register(Default Value: 0x00000002) .....	337
8.2.5.9.	SPI Master Burst Counter Register(Default Value: 0x00000000) .....	337
8.2.5.10.	SPI Master Transmit Counter Register(Default Value: 0x00000000) .....	338
8.2.5.11.	SPI Master Burst Control Counter Register(Default Value: 0x00000000) .....	338

8.2.5.12.	SPI TX Data Register(Default Value: 0x00000000) .....	339
8.2.5.13.	SPI RX Data Register(Default Value: 0x00000000) .....	339
8.3.	UART.....	340
8.3.1.	Overview .....	340
8.3.2.	UART Timing Diagram .....	341
8.3.3.	UART Pin List .....	341
8.3.4.	UART Register List .....	342
8.3.5.	UART Register Description.....	342
8.3.5.1.	UART Receiver Buffer Register(Default Value: 0x00000000) .....	342
8.3.5.2.	UART Transmit Holding Register(Default Value: 0x00000000) .....	343
8.3.5.3.	UART Divisor Latch Low Register(Default Value: 0x00000000).....	343
8.3.5.4.	UART Divisor Latch High Register(Default Value: 0x00000000).....	343
8.3.5.5.	UART Interrupt Enable Register(Default Value: 0x00000000) .....	344
8.3.5.6.	UART Interrupt Identity Register(Default Value: 0x00000000).....	345
8.3.5.7.	UART FIFO Control Register(Default Value: 0x00000000).....	346
8.3.5.8.	UART Line Control Register(Default Value: 0x00000000) .....	347
8.3.5.9.	UART Modem Control Register(Default Value: 0x00000000) .....	348
8.3.5.10.	UART Line Status Register(Default Value: 0x00000060) .....	350
8.3.5.11.	UART Modem Status Register(Default Value: 0x00000000) .....	352
8.3.5.12.	UART Scratch Register(Default Value: 0x00000000) .....	353
8.3.5.13.	UART Status Register(Default Value: 0x00000006).....	354
8.3.5.14.	UART Transmit FIFO Level Register(Default Value: 0x00000000) .....	354
8.3.5.15.	UART Receive FIFO Level Register(Default Value: 0x00000000) .....	355
8.3.5.16.	UART Halt TX Register(Default Value: 0x00000000) .....	355



8.4.	USB .....	357
8.4.1.	USB OTG Controller .....	357
8.4.1.1.	Block Diagram .....	357
8.4.1.2.	USB OTG Register List .....	358
8.4.1.3.	EHCI Register Description .....	359
8.4.1.4.	OHCI Register Description .....	373
8.4.1.5.	HCI Interface Control and PHY Interface Description .....	390
8.5.	EMAC .....	394
8.5.1.	Overview .....	394
8.5.2.	Block Diagram .....	394
8.5.3.	EMAC Core Register List .....	395
8.5.4.	EMAC Core Register Description .....	396
8.5.4.1.	Basic Control 0 Register(Default Value: 0x00000000) .....	396
8.5.4.2.	Basic Control 1 Register(Default Value: 0x08000000) .....	396
8.5.4.3.	Interrupt Status Register(Default Value: 0x00000000) .....	397
8.5.4.4.	Interrupt Enable Register(Default Value: 0x00000000) .....	398
8.5.4.5.	Transmit Control 0 Register(Default Value: 0x00000000) .....	399
8.5.4.6.	Transmit Control 1 Register(Default Value: 0x00000000) .....	399
8.5.4.7.	Transmit Flow Control Register(Default Value: 0x00000000) .....	400
8.5.4.8.	Transmit DMA Descriptor List Address Register(Default Value: 0x00000000) .....	401
8.5.4.9.	Receive Control 0 Register(Default Value: 0x00000000) .....	401
8.5.4.10.	Receive Control 1 Register(Default Value: 0x00000000) .....	401
8.5.4.11.	Receive DMA Descriptor List Address Register(Default Value: 0x00000000) .....	403
8.5.4.12.	Receive Frame Filter Register(Default Value: 0x00000000) .....	403

8.5.4.13.	Receive Hash Table 0 Register(Default Value: 0x00000000).....	404
8.5.4.14.	Receive Hash Table 1 Register(Default Value: 0x00000000).....	404
8.5.4.15.	MII Command Register(Default Value: 0x00000000) .....	405
8.5.4.16.	MII Data Register(Default Value: 0x00000000).....	405
8.5.4.17.	MAC Address 0 High Register(Default Value: 0x0000FFFF) .....	405
8.5.4.18.	MAC Address 0 Low Register(Default Value: 0xFFFFFFFF) .....	406
8.5.4.19.	MAC Address x High Register(Default Value: 0x0000FFFF).....	406
8.5.4.20.	MAC Address x Low Register(Default Value: 0xFFFFFFFF) .....	406
8.5.4.21.	Transmit DMA Status Register(Default Value: 0x00000000).....	407
8.5.4.22.	Transmit DMA Current Descriptor Register(Default Value: 0x00000000).....	407
8.5.4.23.	Transmit DMA Current Buffer Address Register(Default Value: 0x00000000) .....	407
8.5.4.24.	Receive DMA Status Register(Default Value: 0x00000000) .....	407
8.5.4.25.	Receive DMA Current Descriptor Register(Default Value: 0x00000000) .....	408
8.5.4.26.	Receive DMA Current Buffer Address Register(Default Value: 0x00000000) .....	408
8.5.4.27.	RGMII Status Register(Default Value: 0x00000000).....	408
8.5.5.	EMAC RX/TX Descriptor.....	408
8.5.5.1.	Transmit Descriptor .....	409
8.5.5.2.	Receive Descriptor .....	410
Chapter 9	Electrical Characteristics .....	413
9.1.	Absolute Maximum Ratings .....	413
1.98	.....	413
9.2.	Recommended Operating Conditions .....	414
9.3.	DC Electrical Characteristics .....	415
9.4.	Oscillator Electrical Characteristics .....	416

---

9.5. Power on and Power off Sequence .....	417
Appendix .....	419
Pin Map .....	419
Package dimension.....	420

# Chapter 1 About This Documentation

## 1.1. Documentation Overview

This documentation provides an overall description of the Allwinner V3s application processor, which will provide instructions to programmers from several sections, including system, memory, image, display and interface.

## 1.2. Acronyms and abbreviations

The table below contains acronyms and abbreviations used in this document.

A		
AES	Advanced Encryption Standard	A specification for the encryption of electronic data established by the U.S. National Institute of Standards and Technology (NIST) in 2001
AGC	Automatic Gain Control	An adaptive system found in electronic devices that automatically controls the gain of a signal: the average output signal level is fed back to adjust the gain to an appropriate level for a range of input signal levels
AHB	AMBA High-speed Bus	A bus protocol introduced in Advanced Microcontroller Bus Architecture version 2 published by ARM Ltd company
APB	Advanced Peripheral Bus	APB is designed for low bandwidth control accesses, which has an address and data phase similar to AHB, but a much reduced, low complexity signal list (for example no bursts)
AVS	Audio Video Standard	A compression standard for digital audio and video
C		
CRC	Cyclic Redundancy Check	A type of hash function used to produce a checksum in order to detect errors in data storage or transmission
CSI	CMOS Sensor Interface	The hardware block that interfaces with different image sensor interfaces and provides a standard output that can be used for subsequent image processing.

CE	Crypto Engine	The Crypto Engine is one encrypt/ decrypt function accelerator of Allwinner. It can support encryption/ decryption and calculate the hash value.
D		
DES	Data Encryption Standard	A previously predominant algorithm for the encryption of electronic data
DLL	Delay-Locked Loop	A digital circuit similar to a phase-locked loop (PLL), with the main difference being the absence of an internal voltage-controlled oscillator, replaced by a delay line
DRC	Dynamic Range Compression	It reduces the volume of loud sounds or amplifies quiet sounds by narrowing or "compressing" an audio signal's dynamic range.
DVFS	Dynamic Voltage and Frequency Scaling	Dynamic voltage scaling is a power management technique where the voltage used in a component is increased or decreased, depending on circumstances. Dynamic frequency scaling is a technique whereby the frequency of a microprocessor can be automatically adjusted on the fly so that the power consumption or heat generated by the chip can be reduced. These two are often used together to save power in mobile devices.
E		
EHCI	Enhanced Host Controller Interface	The register-level interface for a Host Controller for the USB Revision 2.0.
eMMC	Embedded Multi-Media Card	An architecture consisting of an embedded storage solution with MMC interface, flash memory and controller, all in a small BGA package.
F		
FBGA	Fine Ball Grid Array	FBGA is based on BGA technology, but comes with thinner contacts and is mainly used in SoC design
G		
GIC	Generic Interrupt Controller	A centralized resource for supporting and managing interrupts in a system that includes at least one processor
I		

I2S	Inter IC Sound	An electrical serial bus interface standard used for connecting digital audio devices together
L		
LSB	Least Significant Bit	The bit position in a binary integer giving the units value, that is, determining whether the number is even or odd. It is sometimes referred to as the right-most bit, due to the convention in positional notation of writing less significant digits further to the right.
LRADC	Analog to Digital Converter	Used for KEY Application
M		
MAC	Media Access Control	A sublayer of the data link layer, which provides addressing and channel access control mechanisms that make it possible for several terminals or network nodes to communicate within a multiple access network that incorporates a shared medium, e.g. Ethernet.
MII	Media Independent Interface	An interface originally designed to connect a fast Ethernet MAC-block to a PHY chip, which now has been extended to support reduced signals and increased speeds.
MIPI	Mobile Industry Processor Interface	MIPI alliance is an open membership organization that includes leading companies in the mobile industry that share the objective of defining and promoting open specifications for interfaces inside mobile terminals.
MSB	Most Significant Bit	The bit position in a binary number having the greatest value, which is sometimes referred to as the left-most bit due to the convention in positional notation of writing more significant digits further to the left
N		
NTSC	National Television System Committee	An analog television system that is used in most of North America, and many other countries
O		
OHCI	Open Host Controller Interface	A register-level interface that enables a host controller for USB to communicate with a host controller driver in software
P		

PAL	Phase Alternating Line	An analogue television color encoding system used in broadcast television systems in many countries
PCM	Pulse Code Modulation	A method used to digitally represent sampled analog signals
S		
SPI	Synchronous Peripheral Interface	A synchronous serial data link standard that operates in full duplex mode. Devices communicate in master/slave mode where the master device initiates the data frame.
T		
TWI	Two Wire Interface	A two-wire, bidirectional serial bus that provides simple, efficient method of data exchange, minimizing the interconnection between devices.
U		
USB OTG	Universal Serial Bus On The Go	A Dual Role Device controller, which supports both USB Host and USB Device functions.
UART	Universal Asynchronous Receiver/Transmitter	A serial communication interface, which translates data between parallel and serial forms. UARTs are commonly used in conjunction with communication standards.

## Chapter 2 Overview

The V3s processor represents Allwinner's latest achievement in video encoding processors, which integrates a single ARM Cortex™-A7 CPU that operates at speed up to 1.2GHz with supporting numerous peripherals. The processor targets the need of the growing Car Digital Video Record (DVR) and IP Camera (IPC) Monitor System.

A 512Mbit DDR2 is highly integrated in the V3s, in addition the V3s has optimized external memory interfaces to SPI NAND /Nor flash, SD/MMC.

Dedicated video engine is included to provide an advanced multimedia applications and services. Video Engine supports multi-format such as H.264 encoder by 720p@60fps, H.264 decoder by 1080p@30fps, JPEG/MJPEG decoder by 1080p@30fps. To enrich camera feature, V3s equips an 8M HawkView™ ISP with advanced features like spatial de-noise, chrominance de-noise, zone-based AE/AF/AWB statistics, black level correction, lens shading correction, color correction and anti-flick detection statistics.

To reduce total system cost and enhance overall functionality ,V3s has some popular hardware peripherals such as UART, SPI, USB HS/FS OTG , TWI etc.



## 2.1. Processor Features

### 2.1.1. CPU Architecture

- ARM Cortex™-A7 MP1 Processor
- Thumb-2 Technology
- Support NEON Advanced SIMD(Single Instruction Multiple Data)instruction for acceleration of media and signal processing functions
- Support Large Physical Address Extensions(LPAE)
- VFPv4 Floating Point Unit
- 32KB L1 Instruction cache and 32KB L1 Data cache
- 128KB L2 cache

### 2.1.2. Memory Subsystem

#### 2.1.2.1. Boot ROM

- Internal on-chip memory
- Size:32KB
- Support system boot from the following device:
  - SPI Nor flash
  - SPI Nand flash
  - SD/TF card
  - eMMC
- Support system code download through USB OTG

#### 2.1.2.2. SDRAM

- Internal on-chip memory
- Integrated a 512Mbit DDR2 in V3s processor
- Support clock frequency up to 400MHz
- Support Memory Dynamic Frequency Scale(MDFS)

#### 2.1.2.3. SD/MMC Interface

- External off-chip memory and storage device
- Up to three SD/MMC controllers
- 1/4-bit SD,SDIO,MMC mode

- Complies with eMMC standard specification V4.41, SD physical layer specification V2.0, SDIO card specification V2.0
- Support hardware CRC generation and error detection
- Support block size from 1 to 65535 bytes

### 2.1.3. System Peripheral

#### 2.1.3.1. Timer

- Three on-chip timers with interrupt-based operation
- One watchdogs to generate reset signal or interrupts
- 33 bits Audio/Video Sync(AVS) Counter
- 24MHz or Internal OSC clock input

#### 2.1.3.2. High Speed Timer

- Up to two high speed timers
- Counters up to 56 bits
- Clock source is synchronized with AHB1 clock, much more accurate than other timers

#### 2.1.3.3. GIC

- Support 16 Software Generated Interrupts(SGIs), 16 Private Peripheral Interrupts(PPIs) and 125 Shared Peripheral Interrupts(SPIs)

#### 2.1.3.4. DMA

- Up to 8-channel DMA
- Flexible data width of 8/16/32 bits
- Support linear and IO address modes
- Support data transfer types with memory-to-memory, memory-to-peripheral, peripheral-to-memory

#### 2.1.3.5. CCU

- 9 PLLs
- One on-chip RC oscillator
- One 24MHz external oscillator
- One 32.768KHz external oscillator

- Clock management: clock gating ,clock enabling to the device modules, clock reset, clock generation, clock division

#### 2.1.3.6. PWM

- Up to two PWM channels
- Support outputting two kinds of waveform: continuous waveform and pulse waveform
- 0% to 100% adjustable duty cycle
- Up to 24MHz output frequency

#### 2.1.3.7. RTC

- Time,calendar
- Counters second,minutes,hours,day,week,month and year with leap year generator
- Alarm:general alarm and weekly alarm

#### 2.1.3.8. LRADC

- 6-bit resolution
- Support hold key and continuous key
- Support single key, normal key and continuous key

#### 2.1.3.9. Crypto Engine

- Support AES 128/192/256-bits with ECB,CBC,CTS,CTR mode
- Support DES/TDES with ECB,CBC,CTR mode
- Support SHA1 and MD5
- 160-bits hardware PRNG with 175-bits seed

### 2.1.4. Display Subsystem

#### 2.1.4.1. Display Engine2.0

- Output size up to 1024x1024
- Support three alpha blending channel for main display
- Support four overlay layers in each channel, and has a independent scale
- Support potter-duff compatible blending operation
- Support input format YUV422/YUV420/YUV411/ARGB8888/XRGB8888/RGB888/ARGB4444/ARGB1555/RGB565

### 2.1.4.2. Display Output

- Support RGB interface with DE/SYNC mode, up to 1024x768@60fps
- Support serial RGB/dummy RGB/CCIR656 interface, up to 800x480@60fps
- Support i80 interface with 18/16/9/8 bit, support TE, up to 800x480@60fps
- Support pixel format: RGB888, RGB666 and RGB565
- Dither function from RGB666/RGB565 to RGB888
- Gamma correction with R/G/B channel independence

## 2.1.5. Video Engine

### 2.1.5.1. Video Decoding

- Support video decoder for H.264 and JPEG/MJPEG
- Support H.264 BP/MP/HP up to 1080p@30fps
- Support H.264 output formats :NV21,NV12,YU12,YV12
- Support JPEG/MJPEG up to 1080p@30fps

### 2.1.5.2. Video Encoding

- Support H.264 video encoding up to 720p@60fps
- JPEG baseline: picture size up to 8192x8192
- Support input picture size up to 4800x4800
- Support input format: YU12/YV12/NV12/NV21/YUYV/YVYU/UYVY/VYUY
- Support Alpha blending
- Support thumb generation
- Support 4x2 scaling ratio: from 1/16 to 64 arbitrary non-integer ratio
- Support rotated input

## 2.1.6. Image Subsystem

### 2.1.6.1. Image Input

- Support 8/10/12-bits CMOS sensor parallel interface
- Support 8bit CCIR656 protocol for NTSC and PAL
- Support ITU-R BT 1120 protocol for HD-CIF system
- Support 16bit interface with separate syncs
- Support MIPI-CSI2 interface compliant with MIPI-DPHY v1.0 and MIPI-CSI2 v1.0
- Support MIPI-CSI2 1/2 data lanes configuration
- Support Format:

- YUV422-8/10 bit
- YUV420-8/10bit(for MIPI-CSI2 only)
- RAW-8/10/12bit
- RGB888/RGB565(for MIPI-CSI2 only)
- Performance:
  - Still capture resolution up to 5M with parallel interface
  - Video capture resolution up to 1080p@30fps with parallel interface
  - Still capture resolution up to 5M with MIPI-CSI2 interface
  - Video capture resolution up to 1080p@30fps with MIPI-CSI2 interface
  - MIPI-DPHY maximum data rate up to 1Gbps per lane

### 2.1.6.2. ISP

- Support input formats:8/10-bits RAW RGB,8-bits YCbCr
- Support output formats: YCbCr420 semi-planar,YCrCb420 semi-planar, YCbCr422 semi-planar,YCrCb422 semi-planar,YUV420 planar,YUV422 planar
- Support image mirror flip and rotation
- Support two output channels
- Speed up to 8MPixels@24fps
- Defect pixel correction
- Super lens shading correction
- Anisotropic non-linear Bayer interpolation with false color suppression
- Programmable color correction
- Advanced contrast enhance and sharpening
- Advanced saturation adjust
- Advanced spatial(2D) de-noise filter
- Advanced chrominance noise reduction
- Zone-based AE/AF/AWB statistics
- Anti-flick detection statistics
- Histogram statistics

## 2.1.7. Audio Subsystem

### 2.1.7.1. Audio codec

- Two audio digital-to-analog(DAC) channels
- Support analog/ digital volume control
- One low-noise analog microphone bias output
- Analog low-power loop from microphone to headphone outputs
- Support Dynamic Range Controller adjusting the DAC playback output
- One differential microphone input
- One Stereo Headphone output

- Two audio analog-to-digital(ADC) channels
  - 92dB SNR@A-weight
  - Supports ADC Sample Rates from 8KHz to 48KHz
- Support Automatic Gain Control(AGC) and Dynamic Range Control(DRC) adjusting the ADC recording input

## 2.1.8. External Peripherals

### 2.1.8.1. USB

- One USB 2.0 OTG controller with integrated PHY
- Complies with USB2.0 Specification
- Support High-Speed(HS,480Mbps),Full-Speed(FS,12Mbps),and Low-Speed(LS,1.5Mbps) in host mode
- Complies with Enhanced Host Controller Interface (EHCI) Specification, Version 1.0,and the Open Host Controller Interface(OHCI) Specification,Version 1.0a for host mode
- Up to 8 User-Configurable Endpoints in device mode
- Support point-to-point and point-to-multipoint transfer in both host and peripheral mode

### 2.1.8.2. Ethernet

- Integrated an internal 10/100M PHY
- Support 10/100/1000Mbps data transfer rate
- Support full-duplex and half-duplex operation
- Support linked-list descriptor list structure
- Programmable frame length to support Standard or Jumbo Ethernet frames with sizes up to 16 KB
- Supports a variety of flexible address filtering modes

### 2.1.8.3. UART

- Up to three UART controllers
- 64-Bytes Transmit and receive data FIFOs for all UART
- Compliant with industry-standard 16550 UARTs
- Support Infrared Data Association(IrDA) 1.0 SIR

### 2.1.8.4. SPI

- Full-duplex synchronous serial interface
- Master/Slave configurable
- Mode0~3 are supported for both transmit and receive operations
- Support single and dual read mode

- Two 64-Bytes FIFO for SPI-TX and SPI-RX operation
- DMA-based or interrupt-based operation
- SPI\_Clock(SPI\_CLK) are configurable

#### 2.1.8.5. TWI

- Up to two Two Wire Interface(TWI)controllers
- Support Standard mode(up to 100K bps) and Fast mode(up to 400K bps)
- Master/Slave configurable
- Allows 10-bit addressing transactions

#### 2.1.9. Package

- eLQFP 128(integrated a 512Mbit DDR2)

## 2.2. System Block Diagram

Figure 2-1 shows the block diagram of the V3s.

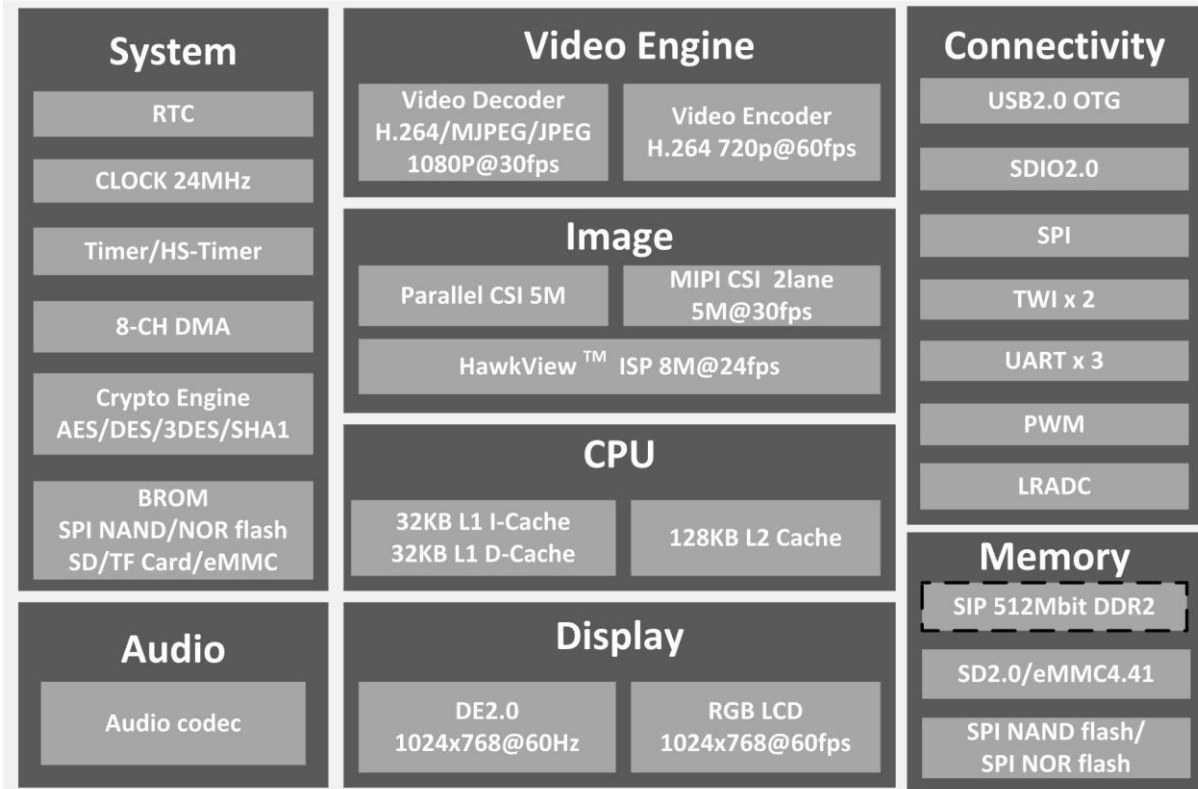

Figure 2-1. V3s Block Diagram



# Chapter 3 Pin Description

## 3.1. Pin Characteristics

Table 3-1 lists the characteristics of V3s Pins from seven aspects: BALL#, Pin Name, Default Function, Type, Reset State, Default Pull Up/Down, and Buffer Strength.

Table 3-1. Pin Characteristics

Ball#	Pin Name	Default Function	Type	Reset State	Default Pull Up/Down	Buffer Strength (mA)
<b>DRAM</b>						
59	VCC-DRAM8	DRAM	P	-	-	-
60	VCC-DRAM9	DRAM	P	-	-	-
61	VCC-DRAM10	DRAM	P	-	-	-
62	VCC-DRAM11	DRAM	P	-	-	-
63	SVREF1	DRAM	P	-	-	-
65	VCC-DRAM0	DRAM	P	-	-	-
66	VCC-DRAM1	DRAM	P	-	-	-
67	VCC-DRAM2	DRAM	P	-	-	-
68	VCC-DRAM3	DRAM	P	-	-	-
69	VCC-DRAM4	DRAM	P	-	-	-
70	VCC-DRAM5	DRAM	P	-	-	-
71	SVREF0	DRAM	P	-	-	-
72	VCC-DRAM6	DRAM	P	-	-	-
73	SZQ	DRAM	A	-	-	-
79	VCC-DRAM7	DRAM	P	-	-	-
<b>GPIO B</b>						
39	PB0	GPIO	I/O	Z	NO PULL	20
40	PB1	GPIO	I/O	Z	NO PULL	20
41	PB2	GPIO	I/O	Z	NO PULL	20
42	PB3	GPIO	I/O	Z	NO PULL	20
43	PB4	GPIO	I/O	Z	NO PULL	20
44	PB5	GPIO	I/O	Z	NO PULL	20
45	PB6	GPIO	I/O	Z	NO PULL	20
46	PB7	GPIO	I/O	Z	NO PULL	20
48	PB8	GPIO	I/O	Z	NO PULL	20
49	PB9	GPIO	I/O	Z	NO PULL	20
<b>GPIO C</b>						
52	PC0	GPIO	I/O	Z	NO PULL	20

Ball#	Pin Name	Default Function	Type	Reset State	Default Pull Up/Down	Buffer Strength (mA)
53	PC1	GPIO	I/O	Z	NO PULL	20
54	PC2	GPIO	I/O	Z	NO PULL	20
55	PC3	GPIO	I/O	Z	NO PULL	20
<b>GPIO E</b>						
37	PE0	GPIO	I/O	Z	NO PULL	20
36	PE1	GPIO	I/O	Z	NO PULL	20
35	PE2	GPIO	I/O	Z	NO PULL	20
34	PE3	GPIO	I/O	Z	NO PULL	20
33	PE4	GPIO	I/O	Z	NO PULL	20
32	PE5	GPIO	I/O	Z	NO PULL	20
31	PE6	GPIO	I/O	Z	NO PULL	20
30	PE7	GPIO	I/O	Z	NO PULL	20
28	PE8	GPIO	I/O	Z	NO PULL	20
27	PE9	GPIO	I/O	Z	NO PULL	20
24	PE10	GPIO	I/O	Z	NO PULL	20
23	PE11	GPIO	I/O	Z	NO PULL	20
22	PE12	GPIO	I/O	Z	NO PULL	20
18	PE13	GPIO	I/O	Z	NO PULL	20
17	PE14	GPIO	I/O	Z	NO PULL	20
16	PE15	GPIO	I/O	Z	NO PULL	20
15	PE16	GPIO	I/O	Z	NO PULL	20
14	PE17	GPIO	I/O	Z	NO PULL	20
13	PE18	GPIO	I/O	Z	NO PULL	20
11	PE19	GPIO	I/O	Z	NO PULL	20
10	PE20	GPIO	I/O	Z	NO PULL	20
9	PE21	GPIO	I/O	Z	NO PULL	20
8	PE22	GPIO	I/O	Z	NO PULL	20
7	PE23	GPIO	I/O	Z	NO PULL	20
6	PE24	GPIO	I/O	Z	NO PULL	20
12	VCC-PE0	POWER	P	-	-	-
29	VCC-PE1	POWER	P	-	-	-
<b>GPIO F</b>						
107	PF0	GPIO	I/O	Z	NO PULL	20
106	PF1	GPIO	I/O	Z	NO PULL	20
105	PF2	GPIO	I/O	Z	NO PULL	20
103	PF3	GPIO	I/O	Z	NO PULL	20
102	PF4	GPIO	I/O	Z	NO PULL	20
101	PF5	GPIO	I/O	Z	NO PULL	20
100	PF6	GPIO	I/O	Z	NO PULL	20
<b>GPIO G</b>						
5	PG0	GPIO	I/O	Z	NO PULL	20

Ball#	Pin Name	Default Function	Type	Reset State	Default Pull Up/Down	Buffer Strength (mA)
4	PG1	GPIO	I/O	Z	NO PULL	20
3	PG2	GPIO	I/O	Z	NO PULL	20
2	PG3	GPIO	I/O	Z	NO PULL	20
1	PG4	GPIO	I/O	Z	NO PULL	20
128	PG5	GPIO	I/O	Z	NO PULL	20
<b>RTC&amp;PLL</b>						
97	RTC-VIO	-	P	-	-	-
96	X32KIN	-	A	-	-	-
95	X32KOUT	-	A	-	-	-
98	VCC-RTC	-	P	-	-	-
76	VCC-PLL	-	P	-	-	-
<b>System Control</b>						
99	RESET	-	I	-	NO PULL	-
75	X24MIN	-	A	-	-	-
74	X24MOUT	-	A	-	-	-
<b>USB</b>						
109	VCC-USB	-	P	-	-	-
110	USB-DM	-	A	-	-	-
111	USB-DP	-	A	-	-	-
<b>AUDIO CODEC</b>						
113	MICIN1P	-	A	-	-	-
114	MICIN1N	-	A	-	-	-
115	AVCC	-	P	-	-	-
116	AGND	-	G	-	-	-
117	VRA1	-	A	-	-	-
118	VRA2	-	A	-	-	-
119	HBIAS	-	A	-	-	-
120	HPOUTR	-	A	-	-	-
121	HPOUTL	-	A	-	-	-
122	HPVCCIN	-	P	-	-	-
123	HPVCCBP	-	A	-	-	-
124	HPCOMFB	-	A	-	-	-
125	HPCOM	-	A	-	-	-
<b>EPHY</b>						
77	EPHY_LINK_LED	-	O	-	-	-
78	EPHY_SPD_LED	-	O	-	-	-
88	EPHY_VDD	-	P	-	-	-
89	EPHY_RXN	-	A	-	-	-
90	EPHY_RXP	-	A	-	-	-
91	EPHY_TXN	-	A	-	-	-
92	EPHY_TXP	-	A	-	-	-

Ball#	Pin Name	Default Function	Type	Reset State	Default Pull Up/Down	Buffer Strength (mA)
93	EPHY_VCC	-	P	-	-	-
94	EPHY_RTX	-	A	-	-	-
<b>LRADC</b>						
112	LRADC0	-	A	-	-	-
<b>MIPI CSI</b>						
81	MCSI-D0P	-	A	-	-	-
82	MCSI-D0N	-	A	-	-	-
83	MCSI-D1P	-	A	-	-	-
84	MCSI-D1N	-	A	-	-	-
85	VCC-MCSI	-	P	-	-	-
86	MCSI-CKP	-	A	-	-	-
87	MCSI-CKN	-	A	-	-	-
<b>Power</b>						
19	VDD-SYS3	-	P	-	-	-
20	VDD-CPU3	-	P	-	-	-
21	VDD-CPU2	-	P	-	-	-
25	VDD-CPU1	-	P	-	-	-
26	VDD-CPU0	-	P	-	-	-
38	VDD-CPU4	-	P	-	-	-
47	VDD-CPU5	-	P	-	-	-
50	VCC-IO3	-	P	-	-	-
51	VDD-CPU6	-	P	-	-	-
56	VDD-CPU7	-	P	-	-	-
57	VCC-IO2	-	P	-	-	-
58	VDD-SYS4	-	P	-	-	-
64	VDD-SYS5	-	P	-	-	-
80	VDD-SYS0	-	P	-	-	-
104	VCC-IO0	-	P	-	-	-
108	VDD-SYS1	-	P	-	-	-
126	VDD-SYS2	-	P	-	-	-
127	VCC-IO1	-	P	-	-	-

**Note:**

- 1) **Default Function** defines the default function of each pin, especially for pins with multiplexing functions;
- 2) **Type** defines the signal direction: I (Input), O (Output), I/O(Input / Output), OD(Open-Drain),A (Analog), AI(Analog Input),AO(Analog Output),A I/O(Analog Input /Output),P (Power), G (Ground);
- 3) **Reset State** defines the state of the terminal at reset: Z for high-impedance ;
- 4) **Default Pull Up/Down** defines the presence of an internal pull up or pull down resistor. Unless otherwise specified, the pin is default to be floating, and can be configured as pull up or pull down;
- 5) **Buffer Strength** defines drive strength of the associated output buffer.

### 3.2. GPIO Multiplex Functions

The following table provides a description of the V3s GPIO multiplexing functions.

Table 3-2. Multiplexing Functions

Pin Name	Default Function	IO Type	Default IO State	Default Pull-up/down	Function 2	Function3	Function 4	Function 5	Function 6
PB0	GPIO	I/O	DIS	Z	UART2_TX	-	-	-	PB_EINT0
PB1		I/O	DIS	Z	UART2_RX	-	-	-	PB_EINT1
PB2		I/O	DIS	Z	UART2_RTS	-	-	-	PB_EINT2
PB3		I/O	DIS	Z	UART2_CTS	-	-	-	PB_EINT3
PB4		I/O	DIS	Z	PWM0	-	-	-	PB_EINT4
PB5		I/O	DIS	Z	PWM1	-	-	-	PB_EINT5
PB6		I/O	DIS	Z	TWI0_SCK	-	-	-	PB_EINT6
PB7		I/O	DIS	Z	TWI0_SDA	-	-	-	PB_EINT7
PB8		I/O	DIS	Z	TWI1_SCK	UART0_TX	-	-	PB_EINT8
PB9		I/O	DIS	Z	TWI1_SDA	UART0_RX	-	-	PB_EINT9
PC0	GPIO	I/O	DIS	Z	SDC2_CLK	SPIO_MISO	-	-	-
PC1		I/O	DIS	Z	SDC2_CMD	SPIO_CLK	-	-	-
PC2		I/O	DIS	Z	SDC2_RST	SPIO_CS	-	-	-
PC3		I/O	DIS	Z	SDC2_D0	SPIO_MOSI	-	-	-
PE0	GPIO	I/O	DIS	Z	CSI_PCLK	LCD_CLK	-	-	-
PE1		I/O	DIS	Z	CSI_MCLK	LCD_DE	-	-	-
PE2		I/O	DIS	Z	CSI_HSYNC	LCD_HSYNC	-	-	-
PE3		I/O	DIS	Z	CSI_VSYNC	LCD_VSYNC	-	-	-
PE4		I/O	DIS	Z	CSI_D0	LCD_D2	-	-	-
PE5		I/O	DIS	Z	CSI_D1	LCD_D3	-	-	-
PE6		I/O	DIS	Z	CSI_D2	LCD_D4	-	-	-
PE7		I/O	DIS	Z	CSI_D3	LCD_D5	-	-	-
PE8		I/O	DIS	Z	CSI_D4	LCD_D6	-	-	-
PE9		I/O	DIS	Z	CSI_D5	LCD_D7	-	-	-
PE10		I/O	DIS	Z	CSI_D6	LCD_D10	-	-	-
PE11		I/O	DIS	Z	CSI_D7	LCD_D11	-	-	-
PE12		I/O	DIS	Z	CSI_D8	LCD_D12	-	-	-
PE13		I/O	DIS	Z	CSI_D9	LCD_D13	-	-	-
PE14		I/O	DIS	Z	CSI_D10	LCD_D14	-	-	-
PE15		I/O	DIS	Z	CSI_D11	LCD_D15	-	-	-
PE16		I/O	DIS	Z	CSI_D12	LCD_D18	-	-	-
PE17		I/O	DIS	Z	CSI_D13	LCD_D19	-	-	-
PE18	I/O	DIS	Z	CSI_D14	LCD_D20	-	-	-	

Pin Name	Default Function	IO Type	Default IO State	Default Pull-up/down	Function 2	Function3	Function 4	Function 5	Function 6
PE19		I/O	DIS	Z	CSI_D15	LCD_D21	-	-	-
PE20		I/O	DIS	Z	CSI_FIELD	CSI_MIPI_M CLK	-	-	-
PE21		I/O	DIS	Z	CSI_SCK	TWI1_SCK	UART1_TX	-	-
PE22		I/O	DIS	Z	CSI_SDA	TWI1_SDA	UART1_RX	-	-
PE23		I/O	DIS	Z	-	LCD_D22	UART1_RTS	-	-
PE24		I/O	DIS	Z	-	LCD_D23	UART1_CTS	-	-
PF0	GPIO	I/O	JTAG_MS	Z	SDC0_D1	JTAG_MS	-	-	-
PF1		I/O	JTAG_DI	Z	SDC0_D0	JTAG_DI	-	-	-
PF2		I/O	DIS	Z	SDC0_CLK	UART0_TX	-	-	-
PF3		I/O	JTAG_DO	Z	SDC0_CMD	JTAG_DO	-	-	-
PF4		I/O	DIS	Z	SDC0_D3	UART0_RX	-	-	-
PF5		I/O	JTAG_CK	Z	SDC0_D2	JTAG_CK	-	-	-
PF6		I/O	DIS	Z	-	-	-	-	-
PG0	GPIO	I/O	DIS	Z	SDC1_CLK	-	-	-	PG_EINT0
PG1		I/O	DIS	Z	SDC1_CMD	-	-	-	PG_EINT1
PG2		I/O	DIS	Z	SDC1_D0	-	-	-	PG_EINT2
PG3		I/O	DIS	Z	SDC1_D1	-	-	-	PG_EINT3
PG4		I/O	DIS	Z	SDC1_D2	-	-	-	PG_EINT4
PG5		I/O	DIS	Z	SDC1_D3	-	-	-	PG_EINT5

### 3.3. Detailed Pin/Signal Description

The following table shows the detailed function description of every pin/signal based on the different interface.

Table 3-3. Detailed Pin Description

Pin/Signal Name	Description	Type
<b>System Control</b>		
RESET	RESET Signal	I
X24MIN	Clock Input Of 24MHz Crystal	AI
X24MOUT	Clock Output Of 24MHz Crystal	AO
<b>RTC&amp;PLL</b>		
RTC-VIO	Internal LDO Output Bypass	P
X32KIN	Clock input of 32768Hz Crystal	AI
X32KOUT	Clock output of 32768Hz Crystal	AO
VCC-RTC	RTC Power Supply	P
<b>USB</b>		
USB-DM0	USB DM Signal	A I/O
USB-DP0	USB DP Signal	A I/O
VCC-USB	USB Power Supply	P
<b>LRADC</b>		
LRADC0	ADC input for key0	AI
<b>AUDIO CODEC</b>		
HPOUTL	Headphone Output Left Channel	AO
HPOUTR	Headphone Output Right Channel	AO
HPVCCIN	Headphone VCC Input	P
HPVCCBP	Headphone VCC Bypass	AO
HPCOM	Headphone Common Reference	AO
HPCOMFB	Headphone Common Reference Feedback Input	AI
HBIAS	Master Analog Microphone Bias	AO
MICIN1N	MIC Negative Input 1	AI
MICIN1P	MIC Positive Input 1	AI
VRA1	Reference Voltage	AO
VRA2	Reference Voltage	AO
AVCC	Power Supply for Analog Part	P
AGND	Ground for Analog Part	G
<b>EPHY</b>		
EPHY_RXP	Transceiver Positive Output/Input	A I/O
EPHY_RXN	Transceiver Negative Output/Input	A I/O
EPHY_TXP	Transceiver Positive Output/Input	A I/O
EPHY_TXN	Transceiver Negative Output/Input	A I/O
EPHY_RTX	EPHY External Resistance to Ground	AI

Pin/Signal Name	Description	Type
EPHY_LINK_LED	EPHY LINK Up/Down Indicator LED	O
EPHY_SPD_LED	EPHY 10M/100M Indicator LED	O
EPHY_VDD	Analog Power Supply for EPHY	P
EPHY_VCC	Analog Power Supply for EPHY	P
<b>SD /MMC</b>		
SDC0_CMD	SD0/MMC0/SDIO0 Command Signal	I/O
SDC0_CLK	SD0/MMC0/SDIO0 Clock	O
SDC0_D[3:0]	SD0/MMC0/SDIO0 Data Input and Output	I/O
SDC1_CMD	SD1/MMC1/SDIO1 Command Signal	I/O
SDC1_CLK	SD1/MMC1/SDIO1 Clock	O
SDC1_D[3:0]	SD1/MMC1/SDIO1 Data Input and Output	I/O
SDC2_CMD	SD2/MMC2/SDIO2 Command Signal	I/O
SDC2_CLK	SD2/MMC2/SDIO2 Clock	O
SDC2_D0	SD2/MMC2/SDIO2 Data 0	I/O
SDC2_RST	SD2/MMC2/SDIO2 Reset Signal	O
<b>Interrupt</b>		
PB_EINT9:0]	GPIO B Interrupt	I
PG_EINT[5:0]	GPIO G Interrupt	I
<b>PWM</b>		
PWM0	Pulse Width Modulation output channel0	O
PWM1	Pulse Width Modulation output channel1	O
<b>LCD</b>		
LCD_D[23:0]	LCD Data Output	O
LCD_CLK	LCD Clock Signal	O
LCD_DE	LCD Data Enable	O
LCD_HSYNC	LCD Horizontal SYNC	O
LCD_VSYNC	LCD Vertical SYNC	O
<b>CSI</b>		
CSI_PCLK	CSI Pixel Clock	I
CSI_MCLK	CSI Master Clock	O
CSI_HSYNC	CSI Horizontal SYNC	I
CSI_VSYNC	CSI Vertical SYNC	I
CSI_D[15:0]	CSI Data bit	I
CSI_SCK	CSI Command Serial Clock Signal	I/O
CSI_SDA	CSI Command Serial Data Signal	I/O
CSI_FIELD	CSI Field Signal	I/O
<b>MIPI_CSI</b>		
MCSI-CKN	MIPI CSI Clock Negative	AI
MCSI-CKP	MIPI CSI Clock Positive	AI
MCSI-DON	MIPI CSI Data0 Negative	AI
MCSI-DOP	MIPI CSI Data0 Positive	AI
MCSI-D1N	MIPI CSI Data1 Negative	AI



Pin/Signal Name	Description	Type
MCSI-D1P	MIPI CSI Data1 Positive	AI
VCC-MCSI	MIPI CSI Power Supply	P
<b>SPI</b>		
SPI_CS0	SPI Chip Select signal	I/O
SPI_CLK	SPI Clock signal	I/O
SPI_MOSI	SPI Master data Out, Slave data In	I/O
SPI_MISO	SPI Master data In, Slave data Out	I/O
<b>UART</b>		
UART0_TX	UART0 Data Transmit	O
UART0_RX	UART0 Data Receive	I
UART1_TX	UART1 Data Transmit	O
UART1_RX	UART1 Data Receive	I
UART1_CTS	UART1 Data Clear To Send	I
UART1_RTS	UART1 Data Request To Send	O
UART2_TX	UART2 Data Transmit	O
UART2_RX	UART2 Data Receive	I
UART2_CTS	UART2 Data Clear To Send	I
UART2_RTS	UART2 Data Request To Send	O
<b>TWI</b>		
TWIO_SCK	TWIO Serial Clock Signal	I/O
TWIO_SDA	TWIO Serial Data Signal	I/O
TWI1_SCK	TWI1 Serial Clock Signal	I/O
TWI1_SDA	TWI1 Serial Data Signal	I/O

## Chapter 4 System

The chapter describes the V3s system from following sections:

- Memory mapping
- Boot system
- CCU
- System control
- Timer
- High-speed Timer
- PWM
- DMA
- GIC
- Crypto Engine
- LRADC
- RTC
- Audio Codec
- Port controller

## 4.1. Memory Mapping

Module	Address	Size (byte)
SRAM A1	0x0000 0000---0x0000 3FFF	16K
SRAM C	0x0000 4000---0x0000 EFFF	44K
DE	0x0100 0000---0x011F FFFF	2M
System Control	0x01C0 0000---0x01C0 0FFF	4K
DMA	0x01C0 2000---0x01C0 2FFF	4K
TCON	0x01C0 C000---0x01C0 CFFF	4K
VE	0x01C0 E000---0x01C0 EFFF	4K
SD/MMC 0	0x01C0 F000---0x01C0 FFFF	4K
SD/MMC 1	0x01C1 0000---0x01C1 0FFF	4K
SD/MMC 2	0x01C1 1000---0x01C1 1FFF	4K
Crypto Engine	0x01C1 5000---0x01C1 5FFF	4K
USB OTG_Device	0x01C1 9000---0x01C1 9FFF	4K
USB OTG_EHCI0/OHCI0	0x01C1 A000---0x01C1 AFFF	4K
CCU	0x01C2 0000---0x01C2 03FF	1K
PIO	0x01C2 0800---0x01C2 0BFF	1K
TIMER	0x01C2 0C00---0x01C2 0FFF	1K
PWM	0x01C2 1400---0x01C2 17FF	1K
LRADC	0x01C2 2800---0x01C2 2BFF	1K
AC	0x01C2 2C00---0x01C2 33FF	2K
UART 0	0x01C2 8000---0x01C2 83FF	1K
UART 1	0x01C2 8400---0x01C2 87FF	1K
UART 2	0x01C2 8800---0x01C2 8BFF	1K
TWI 0	0x01C2 AC00---0x01C2 AFFF	1K
TWI 1	0x01C2 B000---0x01C2 B3FF	1K
EMAC	0x01C3 0000---0x01C3 FFFF	64K
HSTMR	0x01C6 0000---0x01C6 0FFF	4K
DRAMCOM	0x01C6 2000---0x01C6 2FFF	4K
DRAMCTL0	0x01C6 3000---0x01C6 3FFF	4K
DRAMPHY0	0x01C6 5000---0x01C6 5FFF	4K
SPI0	0x01C6 8000---0x01C6 8FFF	4K
SCU Space	0x01C80000 GIC_DIST: 0x01C80000 + 0x1000 GIC_CPUIF:0x01C80000 + 0x2000	
CSI	0x01CB 0000---0x01CF FFFF	320K
RTC	0x01c2 0400---0x01C2 07FF	1K
CoreSight Debug	0x3F50 0000---0x3F51 FFFF	128K
TSGEN RO	0x3F50 6000---0x3F50 6FFF	4K
TSGEN CTRL	0x3F50 7000---0x3F50 7FFF	4K
DDR2	0x4000 0000---0xBFFF FFFF	2G

BROM	0xFFFF 0000—0xFFFF 7FFF	32K
------	-------------------------	-----

## 4.2. Boot System

The boot system can boot from SPI NOR Flash, SPI NAND Flash, SD Card and USB for different application. There is one 32KB ROM In the system .The SPI0,SDC0 controller are used for booting system. One external boot select pin is used for whether system should jump to USB boot. The boot select pin is pull up by internal 50K resistor in normal state. After power up, boot system checks the state of this pin. If it is on low-level state, the system will jump to USB boot.

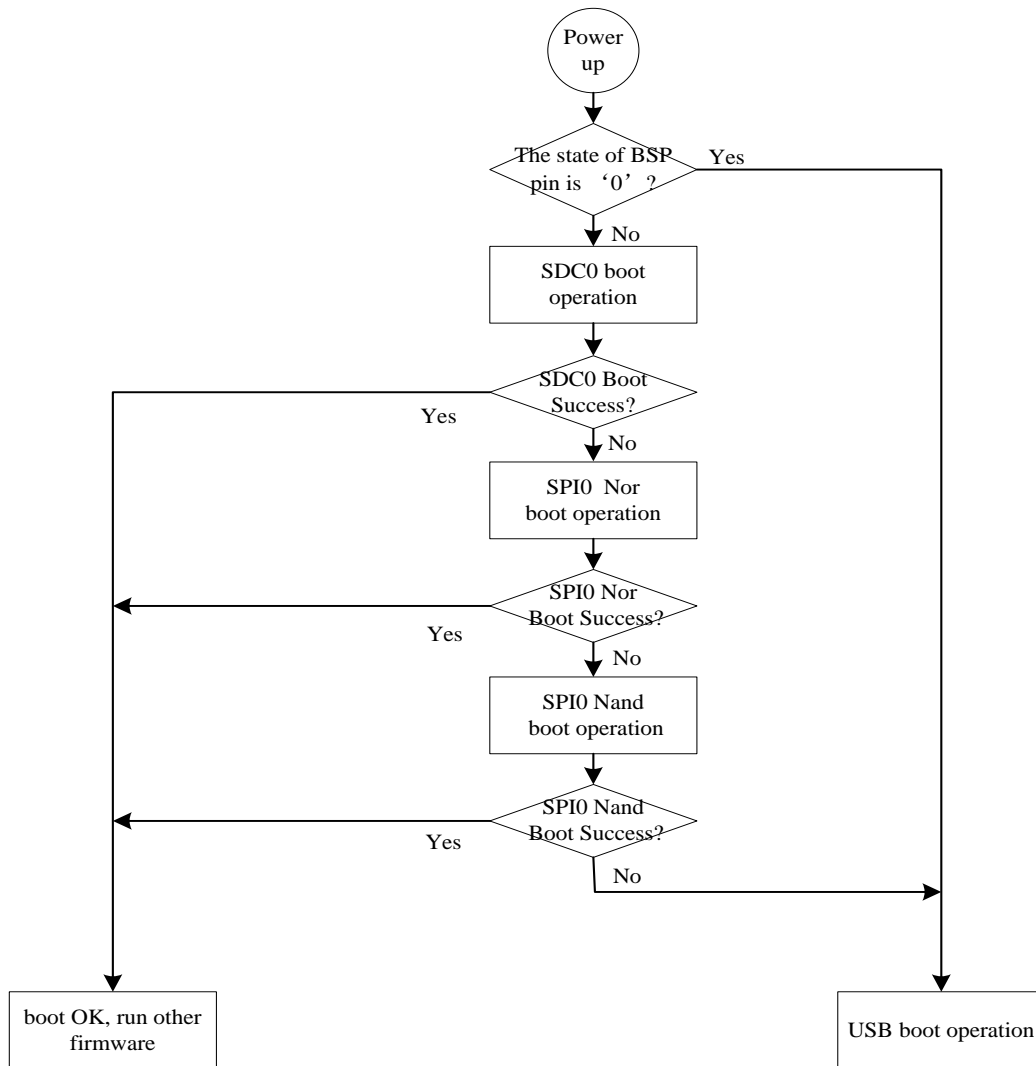

Figure 4-1. Boot System Sequence Diagram

## 4.3. CCU

### 4.3.1. Overview

The CCU controls the PLLs configuration and most of the clock generation, division, distribution, synchronization and gating. CCU input signals include the external clock for the reference frequency (24MHz). The outputs from CCU are mostly clocks to other blocks in the system.

The CCU includes the following features:

- 9 PLLs, independent PLL for CPU
- Bus Source and Divisions
- Clock Output Control
- PLLs Bias Control
- PLLs Tuning Control
- PLLs Pattern Control
- Configuring Modules Clock
- Bus Clock Gating
- Bus Software Reset

### 4.3.2. Functionalities Description

#### 4.3.2.1. System Bus

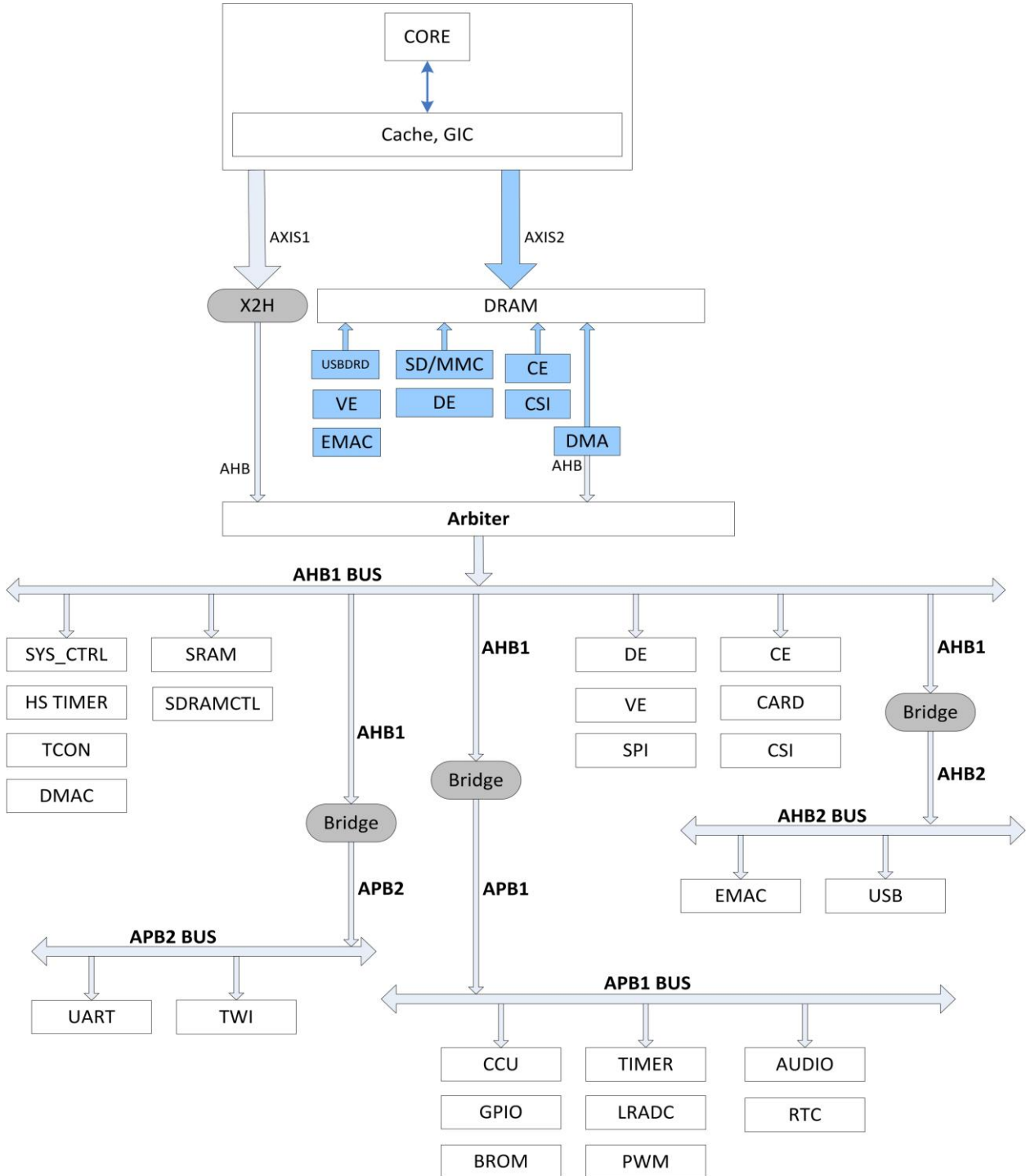

Figure 4-2. System Bus Tree



Clock output of PLL\_DDR1 can be used for DRAM, and dynamic frequency scaling is supported;

#### 4.3.4. Register List

Module Name	Base Address
CCU	0x01C20000

Register Name	Offset	Description
PLL_CPU_CTRL_REG	0x0000	PLL_CPU Control Register
PLL_AUDIO_CTRL_REG	0x0008	PLL_AUDIO Control Register
PLL_VIDEO_CTRL_REG	0x0010	PLL_VIDEO Control Register
PLL_VE_CTRL_REG	0x0018	PLL_VE Control Register
PLL_DDR0_CTRL_REG	0x0020	PLL_DDR0 Control Register
PLL_PERIPH0_CTRL_REG	0x0028	PLL_PERIPH0 Control Register
PLL_ISP_CTRL_REG	0x002C	PLL_ISP Control Register
PLL_PERIPH1_CTRL_REG	0x0044	PLL_PERIPH1 Control Register
PLL_DDR1_CTRL_REG	0x004C	PLL_DDR1 Control Register
CPU_AXI_CFG_REG	0x0050	CPU/AXI Configuration Register
AHB_APB0_CFG_REG	0x0054	AHB/APB0 Configuration Register
APB1_CFG_REG	0x0058	APB1 Configuration Register
AHB2_CFG_REG	0x005C	AHB2 Configuration Register
BUS_CLK_GATING_REG0	0x0060	Bus Clock Gating Register 0
BUS_CLK_GATING_REG1	0x0064	Bus Clock Gating Register 1
BUS_CLK_GATING_REG2	0x0068	Bus Clock Gating Register 2
BUS_CLK_GATING_REG3	0x006C	Bus Clock Gating Register 3
BUS_CLK_GATING_REG4	0x0070	Bus Clock Gating Register4
SDMMC0_CLK_REG	0x0088	SDMMC0 Clock Register
SDMMC1_CLK_REG	0x008C	SDMMC1 Clock Register
SDMMC2_CLK_REG	0x0090	SDMMC2 Clock Register
CE_CLK_REG	0x009C	CE Clock Register
SPI0_CLK_REG	0x00A0	SPI0 Clock Register
USBPHY_CFG_REG	0x00CC	USBPHY Configuration Register
DRAM_CFG_REG	0x00F4	DRAM Configuration Register
PLL_DDR1_CFG_REG	0x00F8	PLL_DDR Configuration Register
MBUS_RST_REG	0x00FC	MBUS Reset Register
DRAM_CLK_GATING_REG	0x0100	DRAM Clock Gating Register
DE_CLK_REG	0x0104	DE Clock Register
TCON_CLK_REG	0x0118	TCON Clock Register
CSI_MISC_CLK_REG	0x0130	CSI_MISC Clock Register
CSI_CLK_REG	0x0134	CSI Clock Register
VE_CLK_REG	0x013C	VE Clock Register
AC_DIG_CLK_REG	0x0140	AC Digital Clock Register
AVS_CLK_REG	0x0144	AVS Clock Register



MBUS_CLK_REG	0x015C	MBUS Clock Register
MIPI_CSI_REG	0x016C	MIPI_CSI Register
PLL_STABLE_TIME_REG0	0x0200	PLL Stable Time Register0
PLL_STABLE_TIME_REG1	0x0204	PLL Stable Time Register1
PLL_CPU_BIAS_REG	0x0220	PLL_CPU Bias Register
PLL_AUDIO_BIAS_REG	0x0224	PLL_AUDIO Bias Register
PLL_VIDEO_BIAS_REG	0x0228	PLL_VIDEO Bias Register
PLL_VE_BIAS_REG	0x022C	PLL_VE Bias Register
PLL_DDR0_BIAS_REG	0x0230	PLL_DDR0 Bias Register
PLL_PERIPH0_BIAS_REG	0x0234	PLL_PERIPH0 Bias Register
PLL_ISP_BIAS_REG	0x0238	PLL_ISP Bias Register
PLL_PERIPH1_BIAS_REG	0x0244	PLL_PERIPH1 Bias Register
PLL_DDR1_BIAS_REG	0x024C	PLL_DDR1 Bias Register
PLL_CPU_TUN_REG	0x0250	PLL_CPU Tuning Register
PLL_DDR0_TUN_REG	0x0260	PLL_DDR0 Tuning Register
PLL_CPU_PAT_CTRL_REG	0x0280	PLL_CPU Pattern Control Register
PLL_AUDIO_PAT_CTRL_REG	0x0284	PLL_AUDIO Pattern Control Register
PLL_VIDEO_PAT_CTRL_REG	0x0288	PLL_VIDEO Pattern Control Register
PLL_VE_PAT_CTRL_REG	0x028C	PLL_VE Pattern Control Register
PLL_DDR0_PAT_CTRL_REG	0x0290	PLL_DDR0 Pattern Control Register
PLL_ISP_PAT_CTRL_REG	0x0298	PLL_ISP Pattern Control Register
PLL_PERIPH1_PAT_CTRL_REG	0x02A4	PLL_PERIPH1 Pattern Control Register
PLL_DDR1_PAT_CTRL_REG0	0x02AC	PLL_DDR1 Pattern Control Register0
PLL_DDR1_PAT_CTRL_REG1	0x02B0	PLL_DDR1 Pattern Control Register1
BUS_SOFT_RST_REG0	0x02C0	Bus Software Reset Register 0
BUS_SOFT_RST_REG1	0x02C4	Bus Software Reset Register 1
BUS_SOFT_RST_REG2	0x02C8	Bus Software Reset Register 2
BUS_SOFT_RST_REG3	0x02D0	Bus Software Reset Register 3
BUS_SOFT_RST_REG4	0x02D8	Bus Software Reset Register 4
PS_CTRL_REG	0x0300	PS Control Register
PS_CNT_REG	0x0304	PS Counter Register

### 4.3.5. Register Description

#### 4.3.5.1. PLL\_CPU Control Register (Default Value: 0x00001000)

Offset: 0x0000			Register Name: <b>PLL_CPU_CTRL_REG</b>
Bit	R/W	Default/Hex	Description
31	R/W	0x0	PLL_ENABLE. 0: Disable

			1: Enable The PLL Output= (24MHz*N*K)/(M*P). The PLL output is for the CPUX Clock. Note: The PLL output clock must be in the range of 200MHz~2.6GHz. Its default is 408MHz.
30:29	/	/	/
28	R	0x0	LOCK 0: Unlocked 1: Locked (It indicates that the PLL has been stable.)
27:25	/	/	/
24	R/W	0x0	CPUX_SDM_EN. 0: Disable 1: Enable
23:18	/	/	/
17:16	R/W	0x0	PLL_OUT_EXT_DIVP PLL Output external divider P 00: /1 01: /2 10: /4 11: / Note:The P factor only use in the condition that PLL output less than 288 MHz.
15:13	/	/	/
12:8	R/W	0x10	PLL_FACTOR_N PLL Factor N. Factor=0, N=1 Factor=1, N=2 Factor=2, N=3 ..... Factor=31, N=32
7:6	/	/	/
5:4	R/W	0x0	PLL_FACTOR_K. PLL Factor K.(K=Factor + 1 ) The range is from 1 to 4.
3:2	/	/	/
1:0	R/W	0x0	PLL_FACTOR_M. PLL Factor M. (M=Factor + 1) The range is from 1 to 4.

#### 4.3.5.2. PLL\_Audio Control Register (Default Value: 0x00035514)

Offset: 0x0008			Register Name: <b>PLL_AUDIO_CTRL_REG</b>
Bit	R/W	Default/Hex	Description
31	R/W	0x0	PLL_ENABLE.

			0: Disable 1: Enable. The PLL is for Audio. $PLL\_AUDIO = (24MHz * N) / (M * P)$ $PLL\_AUDIO(8X) = (24MHz * N * 2) / M$ $PLL\_AUDIO(4X) = PLL\_AUDIO(8X) / 2$ $PLL\_AUDIO(2X) = PLL\_AUDIO(4X) / 2$ The PLL output clock must be in the range of 20MHz~200MHz. Its default is 24.571MHz.
30:29	/	/	/
28	R	0x0	LOCK. 0: Unlocked 1: Locked (It indicates that the PLL has been stable.)
27:25	/	/	/
24	R/W	0x0	PLL_SDM_EN. 0: Disable 1: Enable In this case, the PLL_FACTOR_N only low 4 bits are valid (N: The range is from 1 to 16).
23:20	/	/	/
19:16	R/W	0x3	PLL_POSTDIV_P. Post-div factor (P= Factor+1) The range is from 1 to 16.
15	/	/	/
14:8	R/W	0x55	PLL_FACTOR_N. PLL Factor N. Factor=0, N=1 Factor=1, N=2 ..... Factor=127, N=128
7:5	/	/	/
4:0	R/W	0x14	PLL_PREDIV_M. PLL Pre-div Factor(M = Factor+1). The range is from 1 to 32.

#### 4.3.5.3. PLL\_VIDEO Control Register (Default Value: 0x03006207)

Offset: 0x0010			Register Name: <b>PLL_VIDEO_CTRL_REG</b>
Bit	R/W	Default/Hex	Description
31	R/W	0x0	PLL_ENABLE. 0: Disable 1: Enable In the integer mode, the PLL Output = $(24MHz * N) / M$ . In the fractional mode, the PLL Output is select by bit 25.

			Note: In the Clock Control Module, PLL(1X) Output=PLL while PLL(2X) Output=PLL * 2. The PLL output clock must be in the range of 30MHz~600MHz. Its default is 297MHz.
30	R/W	0x0	PLL_MODE. 0: Manual Mode 1: Auto Mode (Controlled by DE)
29	/	/	/
28	R	0x0	LOCK. 0: Unlocked 1: Locked (It indicates that the PLL has been stable.)
27:26	/	/	/
25	R/W	0x1	FRAC_CLK_OUT. PLL clock output when PLL_MODE_SEL=0(PLL_PREDIV_M factor must be set to 0); No meaning when PLL_MODE_SEL =1. 0: PLL Output=270MHz 1: PLL Output =297MHz
24	R/W	0x1	PLL_MODE_SEL. 0: Fractional Mode 1: Integer Mode Note: When in Fractional mode, the Per Divider M should be set to 0.
23:21	/	/	/
20	R/W	0x0	PLL_SDM_EN. 0: Disable 1: Enable
19:15	/	/	/
14:8	R/W	0x62	PLL_FACTOR_N. PLL Factor N. Factor=0, N=1 Factor=1, N=2 Factor=2, N=3 ..... Factor=127, N=128
7:4	/	/	/
3:0	R/W	0x7	PLL_PREDIV_M. PLL Pre-div Factor(M = Factor+1). The range is from 1 to 16.

#### 4.3.5.4. PLL\_VE Control Register (Default Value: 0x03006207)

Offset: 0x0018			Register Name: <b>PLL_VE_CTRL_REG</b>
Bit	R/W	Default/Hex	Description
31	R/W	0x0	PLL_ENABLE. 0: Disable

			1: Enable In the integer mode, The PLL Output = (24MHz*N)/M. In the fractional mode, the PLL Output is select by bit 25. Note: The PLL output clock must be in the range of 30MHz~600MHz. Its default is 297MHz.
30:29	/	/	/
28	R	0x0	LOCK 0: Unlocked 1: Locked (It indicates that the PLL has been stable.)
27:26	/	/	/
25	R/W	0x1	FRAC_CLK_OUT. PLL clock output when PLL_MODE_SEL=0(PLL_PREDIV_M factor must be set to 0); No meaning when PLL_MODE_SEL =1. 0: PLL Output=270MHz 1: PLL Output =297MHz
24	R/W	0x1	PLL_MODE_SEL. 0: Fractional Mode 1: Integer Mode Note: When in Fractional mode, the Per Divider M should be set to 0.
23:21	/	/	/
20	R/W	0x0	PLL_SDM_EN. 0: Disable 1: Enable
19:15	/	/	/
14:8	R/W	0x62	PLL_FACTOR_N. PLL Factor N. Factor=0, N=1 Factor=1, N=2 Factor=2, N=3 ..... Factor=31, N=32 ... Factor=127, N=128
7:4	/	/	/
3:0	R/W	0x7	PLL_PREDIV_M. PLL Pre Divider (M = Factor+1). The range is from 1 to 16.

#### 4.3.5.5. PLL\_DDR0 Control Register (Default Value: 0x00001000)

Offset: 0x0020			Register Name: <b>PLL_DDR0_CTRL_REG</b>
Bit	R/W	Default/Hex	Description
31	R/W	0x0	PLL_ENABLE. 0: Disable

			1: Enable Set bit20 to validate the PLL after this bit is set to 1. The PLL Output = (24MHz*N*K)/M. Note: the PLL output clock must be in the range of 200MHz~2.6GHz. Its default is 408MHz.
30:29	/	/	/
28	R	0x0	LOCK 0: Unlocked 1: Locked (It indicates that the PLL has been stable.)
27:25	/	/	/
24	R/W	0x0	PLL_SDM_EN. 0: Disable 1: Enable
23:21	/	/	/
20	R/W	0x0	PLL_DDR_CFG_UPDATE. PLL_DDR Configuration Update. When PLL_DDR has been changed, this bit should be set to 1 to validate the PLL, otherwise the change would be invalid. And this bit would be cleared automatically after the PLL change is valid. 0: No effect 1: Validating the PLL_DDR
19:13	/	/	/
12:8	R/W	0x10	PLL_FACTOR_N. PLL Factor N. Factor=0, N=1 Factor=1, N=2 Factor=2, N=3 ..... Factor=31, N=32
7:6	/	/	/
5:4	R/W	0x0	PLL_FACTOR_K. PLL Factor K.(K=Factor + 1) The range is from 1 to 4.
3:2	/	/	/
1:0	R/W	0x0	PLL_FACTOR_M. PLL Factor M.(M = Factor + 1) The range is from 1 to 4.

#### 4.3.5.6. PLL\_PERIPH0 Control Register (Default Value: 0x00041811)

Offset: 0x0028			Register Name: <b>PLL_PERIPH0_CTRL_REG</b>
Bit	R/W	Default/Hex	Description
31	R/W	0x0	PLL_ENABLE. 0: Disable

			<p>1: Enable</p> <p>The PLL Output = <math>24\text{MHz} * N * K / 2</math>.</p> <p>Note: The PLL Output should be fixed to 600MHz, it is not recommended to vary this value arbitrarily.</p> <p>In the Clock Control Module, PLL(2X) output= <math>\text{PLL} * 2 = 24\text{MHz} * N * K</math>.</p> <p>The PLL output clock must be in the range of 200MHz~1.8GHz.</p> <p>Its default is 600MHz.</p>
30:29	/	/	/
28	R	0x0	<p>LOCK.</p> <p>0: Unlocked</p> <p>1: Locked (It indicates that the PLL has been stable.)</p>
27:26	/	/	/
25	R/W	0x0	<p>PLL_BYPASS_EN.</p> <p>PLL Output Bypass Enable.</p> <p>0: Disable</p> <p>1: Enable</p> <p>If the bypass is enabled, the PLL output is 24MHz.</p>
24	R/W	0x0	<p>PLL_CLK_OUT_EN.</p> <p>PLL clock output enable.</p> <p>0: Disable</p> <p>1: Enable</p>
23:19	/	/	/
18	R/W	0x1	<p>PLL_24M_OUT_EN.</p> <p>PLL 24MHz Output Enable.</p> <p>0: Disable</p> <p>1: Enable</p> <p>When 25MHz crystal used, this PLL can output 24MHz.</p>
17:16	R/W	0x0	<p>PLL_24M_POST_DIV.</p> <p>PLL 24M Output Clock Post Divider (When 25MHz crystal used).</p> <p>1/2/3/4.</p>
15:13	/	/	/
12:8	R/W	0x18	<p>PLL_FACTOR_N.</p> <p>PLL Factor N.</p> <p>Factor=0, N=1</p> <p>Factor=1, N=2</p> <p>Factor=2, N=3</p> <p>.....</p> <p>Factor=31, N=32</p>
7:6	/	/	/
5:4	R/W	0x1	<p>PLL_FACTOR_K.</p> <p>PLL Factor K.(<math>K = \text{Factor} + 1</math>)</p> <p>The range is from 1 to 4.</p>
3:2	/	/	/
1:0	R/W	0x1	<p>PLL_FACTOR_M.</p> <p>PLL Factor M (<math>M = \text{Factor} + 1</math>) is only valid in plltest debug.</p>

			<p>The PLL_PERIPH back door clock output =24MHz*N*K/M. The range is from 1 to 4.</p>
--	--	--	--

**4.3.5.7. PLL\_ISP Control Register (Default Value: 0x03006207)**

Offset: 0x002C			Register Name: PLL_ISP_CTRL_REG
Bit	R/W	Default/Hex	Description
31	R/W	0x0	<p>PLL_ENABLE. 0: Disable 1: Enable In the integer mode,the PLL Output = (24MHz*N)/M. In the fractional mode, the PLL Output is select by bit 25. Note: In the Clock Control Module, PLL(1X) Output=PLL while PLL(2X) Output=PLL * 2. The PLL output clock must be in the range of 30MHz~600MHz. Its default is 297MHz.</p>
30	R/W	0x0	<p>PLL_MODE. 0: Manual Mode 1: Auto Mode (Controlled by DE)</p>
29	/	/	/
28	R	0x0	<p>LOCK. 0: Unlocked 1: Locked (It indicates that the PLL has been stable.)</p>
27:26	/	/	/
25	R/W	0x1	<p>FRAC_CLK_OUT. PLL clock output when PLL_MODE_SEL=0(PLL_PREDIV_M factor must be set to 0); No meaning when PLL_MODE_SEL =1. 0: PLL Output=270MHz 1: PLL Output =297MHz</p>
24	R/W	0x1	<p>PLL_MODE_SEL. 0: Fractional Mode 1: Integer Mode Note: When in Fractional mode, the Per Divider M should be set to 0.</p>
23:21	/	/	/
20	R/W	0x0	<p>PLL_SDM_EN. 0: Disable 1: Enable</p>
19:15	/	/	/
14:8	R/W	0x62	<p>PLL_FACTOR_N. PLL Factor N. Factor=0, N=1 Factor=1, N=2 Factor=2, N=3 .....</p>



			Factor=127,N=128
7:4	/	/	/
3:0	R/W	0x7	PLL_PREDIV_M. PLL Pre-div Factor(M = Factor+1). The range is from 1 to 16.

#### 4.3.5.8. PLL\_PERIPH1 Control Register (Default Value: 0x00041811)

Offset: 0x0044			Register Name: PLL_PERIPH1_CTRL_REG
Bit	R/W	Default/Hex	Description
31	R/W	0x0	PLL_ENABLE. 0: Disable 1: Enable The PLL Output = 24MHz*N*K/2. Note: The PLL Output should be fixed to 600MHz, it is not recommended to vary this value arbitrarily. In the Clock Control Module, PLL(2X) output= PLL*2 = 24MHz*N*K. The PLL output clock must be in the range of 200MHz~1.8GHz. Its default is 600MHz.
30:29	/	/	/
28	R	0x0	LOCK. 0: Unlocked 1: Locked (It indicates that the PLL has been stable.)
27:26	/	/	/
25	R/W	0x0	PLL_BYPASS_EN. PLL Output Bypass Enable. 0: Disable 1: Enable If the bypass is enabled, the PLL output is 24MHz.
24	R/W	0x0	PLL_CLK_OUT_EN. PLL clock output enable(Just for the SATA Phy) 0: Disable 1: Enable
23:21	/	/	/
20	R/W	0x0	PLL_SDM_EN. 0: Disable 1: Enable
19	/	/	/
18	R/W	0x1	PLL_24M_OUT_EN. PLL 24MHz Output Enable. 0: Disable 1: Enable When 25MHz crystal used, this PLL can output 24MHz.
17:16	R/W	0x0	PLL_24M_POST_DIV.

			PLL 24M Output Clock Post Divider (When 25MHz crystal used). 1/2/3/4.
15:13	/	/	/
12:8	R/W	0x18	PLL_FACTOR_N. PLL Factor N. Factor=0, N=1 Factor=1, N=2 Factor=2, N=3 ..... Factor=31, N=32
7:6	/	/	/
5:4	R/W	0x1	PLL_FACTOR_K. PLL Factor K.(K=Factor + 1 ) The range is from 1 to 4.
3:2	/	/	/
1:0	R/W	0x1	PLL_FACTOR_M. PLL Factor M (M = Factor + 1) is only valid in plltest debug. The PLL_PERIPH back door clock output =24MHz*N*K/M. The range is from 1 to 4.

#### 4.3.5.9. PLL\_DDR1 Control Register (Default Value: 0x00001800)

Offset: 0x004C			Register Name: PLL_DDR1_CTRL_REG
Bit	R/W	Default/Hex	Description
31	R/W	0x0	PLL_ENABLE. 0: Disable 1: Enable. The PLL Output = 24MHz*N/M. Its default is 600 MHz.
30	R/W	0x0	SDRPLL_UPD. SDRPLL Configuration Update. Note: When PLL_DDR1 has changed, this bit should be set to 1 to validate the PLL, otherwise the change is invalid. It will be auto cleared after the PLL is valid. 0: No effect 1: To validate the PLL_DDR1.
29	/	/	/
28	R	0x0	LOCK 0:Unlocked 1: Locked (It indicates that the PLL has been stable.)
27:25	/	/	/
24	R/W	0x0	PLL_SDM_EN. 0: Disable 1: Enable.

23:16	/	/	/
15:8	R/W	0x18	PLL_FACTOR_N. PLL Factor N. (N = Factor + 1 ) The range is from 0 to 127. Note: Bit 15 can not be accessed.
7:2	/	/	/
1:0	R/W	0x0	PLL_FACTOR_M. PLL Factor M.(M = Factor + 1 ) The range is from 1 to 4.

#### 4.3.5.10. CPU/AXI Configuration Register (Default Value: 0x00010000)

Offset: 0x0050			Register Name: <b>CPU_AXI_CFG_REG</b>
Bit	R/W	Default/Hex	Description
31:18	/	/	/
17:16	R/W	0x1	CPU_CLK_SRC_SEL. CPU Clock Source Select. CPU Clock = Clock Source 00: LOSC 01: OSC24M 1X: PLL_CPU If the clock source is changed, at most to wait for 8 present running clock cycles.
15:10	/	/	/
9:8	R/W	0x0	CPU_APB_CLK_DIV. 00: /1 01: /2 1x: /4 Note: System APB clock source is CPU clock source.
7:2	/	/	/
1:0	R/W	0x0	AXI_CLK_DIV_RATIO. AXI Clock Divide Ratio. AXI Clock source is CPU clock source. 00: /1 01: /2 10: /3 11: /4

#### 4.3.5.11. AHB1/APB1 Configuration Register (Default Value: 0x00001010)

Offset: 0x0054			Register Name: <b>AHB1_APB1_CFG_REG</b>
Bit	R/W	Default/Hex	Description

31:14	/	/	/
13:12	R/W	0x1	AHB1_CLK_SRC_SEL. 00: LOSC 01: OSC24M 10: AXI 11: PLL_PERIPH0/ AHB1_PRE_DIV
11:10	/	/	/
9:8	R/W	0x0	APB1_CLK_RATIO. APB1 Clock Divide Ratio. APB1 clock source is AHB1 clock. 00: /2 01: /2 10: /4 11: /8
7:6	R/W	0x0	AHB1_PRE_DIV AHB1 Clock Pre Divide Ratio 00: /1 01: /2 10: /3 11: /4
5:4	R/W	0x1	AHB1_CLK_DIV_RATIO. AHB1 Clock Divide Ratio. 00: /1 01: /2 10: /4 11: /8
3:0	/	/	/

#### 4.3.5.12. APB2 Configuration Register (Default Value: 0x01000000)

Offset: 0x0058			Register Name: <b>APB2_CFG_REG</b>
Bit	R/W	Default/Hex	Description
31:26	/	/	/
25:24	R/W	0x1	APB2_CLK_SRC_SEL. APB2 Clock Source Select 00: LOSC 01: OSC24M 1X: PLL_PERIPH0 This clock is used for some special module apbclk(UART、TWI). Because these modules need special clock rate even if the apb1clk changed.
23:18	/	/	/
17:16	R/W	0x0	CLK_RAT_N Clock Pre Divide Ratio (n) The select clock source is pre-divided by 2^n. The divider is 1/2/4/8.
15:5	/	/	/

4:0	R/W	0x0	CLK_RAT_M. Clock Divide Ratio (m) The Pre Divide clock is divided by (m+1). The divider M is from 1 to 32.
-----	-----	-----	--

**4.3.5.13. AHB2 Configuration Register (Default Value: 0x00000000)**

Offset: 0x005C			Register Name: <b>AHB2_CFG_REG</b>
Bit	R/W	Default/Hex	Description
31:2	/	/	/
1:0	R/W	0x0	AHB2_CLK_CFG. 00: AHB1 Clock 01: PLL_PERIPH0 / 2 1X: / EMAC,USB OTG_EHCI0/OHCI0 and USB OTG_Device0 default clock source is AHB2 Clock.

**4.3.5.14. Bus Clock Gating Register0 (Default Value: 0x00000000)**

Offset: 0x0060			Register Name: <b>BUS_CLK_GATING_REG0</b>
Bit	R/W	Default/Hex	Description
31:30	/	/	/
29	R/W	0x0	USB OTG_OHCI_GATING. Gating Clock for USB OTG_OHCI 0: Mask 1: Pass
28:27	/	/	/
26	R/W	0x0	USB OTG_EHCI_GATING. Gating Clock For USB OTG_EHCI 0: Mask 1: Pass
25	/	/	/
24	R/W	0x0	USB OTG_Device_GATING. Gating Clock For USB OTG_Device 0: Mask 1: Pass
23:21	/	/	/
20	R/W	0x0	SPIO_GATING. Gating Clock For SPIO 0: Mask 1: Pass
19	R/W	0x0	HSTMR_GATING. Gating Clock For High Speed Timer

			0: Mask 1: Pass
18	/	/	/
17	R/W	0x0	EMAC_GATING. Gating Clock For EMAC 0: Mask 1: Pass
16:15	/	/	/
14	R/W	0x0	DRAM_GATING. Gating Clock For DRAM 0: Mask 1: Pass
13:11	/	/	/
10	R/W	0x0	MMC2_GATING. Gating Clock For MMC2 0: Mask 1: Pass
9	R/W	0x0	MMC1_GATING. Gating Clock For MMC1 0: Mask 1: Pass
8	R/W	0x0	MMC0_GATING. Gating Clock For MMC0 0: Mask 1: Pass
7	/	/	/
6	R/W	0x0	DMA_GATING. Gating Clock For DMA 0: Mask 1: Pass
5	R/W	0x0	CE_GATING. Gating Clock For CE. 0: Mask 1: Pass
4:0	/	/	/

#### 4.3.5.15. Bus Clock Gating Register1 (Default Value: 0x00000000)

Offset: 0x0064			Register Name: <b>BUS_CLK_GATING_REG1</b>
Bit	R/W	Default/Hex	Description
31:13	/	/	/
12	R/W	0x0	DE_GATING. 0: Mask 1: Pass.

11:9	/	/	/
8	R/W	0x0	CSI_GATING. Gating Clock For CSI 0: Mask 1: Pass
7:5	/	/	/
4	R/W	0x0	TCON_GATING. Gating Clock For TCON 0: Mask 1: Pass
3:1	/	/	/
0	R/W	0x0	VE_GATING. Gating Clock For VE 0: Mask 1: Pass

#### 4.3.5.16. Bus Clock Gating Register2 (Default Value: 0x00000000)

Offset: 0x0068			Register Name: <b>BUS_CLK_GATING_REG2</b>
Bit	R/W	Default/Hex	Description
31:13	/	/	/
12	R/W	0x0	/
11:6	/	/	/
5	R/W	0x0	PIO_GATING. Gating Clock For PIO 0: Mask 1: Pass
4:1	/	/	/
0	R/W	0x0	AC_DIG_GATING. Gating Clock For AC Digital 0: Mask 1: Pass

#### 4.3.5.17. Bus Clock Gating Register3 (Default Value: 0x00000000)

Offset: 0x006C			Register Name: <b>BUS_CLK_GATING_REG3</b>
Bit	R/W	Default/Hex	Description
31:19	/	/	/
18	R/W	0x0	UART2_GATING. Gating Clock For UART2 0: Mask 1: Pass

17	R/W	0x0	UART1_GATING. Gating Clock For UART1 0: Mask 1: Pass
16	R/W	0x0	UART0_GATING. Gating Clock For UART0 0: Mask 1: Pass
15:2	/	/	/
1	R/W	0x0	TWI1_GATING. Gating Clock For TWI1 0: Mask 1: Pass
0	R/W	0x0	TWI0_GATING. Gating Clock For TWI0 0: Mask 1: Pass

#### 4.3.5.18. Bus Clock Gating Register4 (Default Value: 0x00000000)

Offset: 0x0070			Register Name: <b>BUS_CLK_GATING_REG4</b>
Bit	R/W	Default/Hex	Description
31:8	/	/	/
7	R/W	0x0	DBGSYS_GATING. Gating Clock For DBGSYS 0: Mask 1: Pass
6:1	/	/	/
0	R/W	0x0	EPHY_GATING. Gating Clock For EPHY 0: Mask 1: Pass

#### 4.3.5.19. SDMMC0 Clock Register (Default Value: 0x00000000)

Offset: 0x0088			Register Name: <b>SDMMC0_CLK_REG</b>
Bit	R/W	Default/Hex	Description
31	R/W	0x0	SCLK_GATING. Gating Special Clock(Max Clock = 200MHz) 0: Clock is OFF 1: Clock is ON. SCLK = Clock Source/Divider N/Divider M.



30:26	/	/	/
25:24	R/W	0x0	CLK_SRC_SEL. Clock Source Select 00: OSC24M 01: PLL_PERIPH0 10: PLL_PERIPH1 11: /
23	/	/	/
22:20	R/W	0x0	SAMPLE_CLK_PHASE_CTR. Sample Clock Phase Control. The sample clock phase delay is based on the number of source clock that is from 0 to 7.
19:18	/	/	/
17:16	R/W	0x0	CLK_DIV_RATIO_N. Clock Pre Divide Ratio (n) 00: /1 01: /2 10: /4 11: /8.
15:11	/	/	/
10:8	R/W	0x0	OUTPUT_CLK_PHASE_CTR. Output Clock Phase Control. The output clock phase delay is based on the number of source clock that is from 0 to 7.
7:4	/	/	/
3:0	R/W	0x0	CLK_DIV_RATIO_M. Clock Divide Ratio (m) The pre-divided clock is divided by (m+1). The divider M is from 1 to 16.

#### 4.3.5.20. SDMMC1 Clock Register (Default Value: 0x00000000)

Offset: 0x008C			Register Name: <b>SDMMC1_CLK_REG</b>
Bit	R/W	Default/Hex	Description
31	R/W	0x0	SCLK_GATING. Gating Special Clock(Max Clock = 200MHz) 0: Clock is OFF 1: Clock is ON.
30:26	/	/	/
25:24	R/W	0x0	CLK_SRC_SEL. Clock Source Select 00: OSC24M 01: PLL_PERIPH0 10: PLL_PERIPH1 11: /

23	/	/	/
22:20	R/W	0x0	SAMPLE_CLK_PHASE_CTR. Sample Clock Phase Control. The sample clock phase delay is based on the number of source clock that is from 0 to 7.
19:18	/	/	/
17:16	R/W	0x0	CLK_DIV_RATIO_N. Clock Pre-Divide Ratio (n) 00: /1 01: /2 10: /4 11: /8.
15:11	/	/	/
10:8	R/W	0x0	OUTPUT_CLK_PHASE_CTR. Output Clock Phase Control. The output clock phase delay is based on the number of source clock that is from 0 to 7.
7:4	/	/	/
3:0	R/W	0x0	CLK_DIV_RATIO_M. Clock Divide Ratio (m) The pre-divided clock is divided by (m+1). The divider M is from 1 to 16.

#### 4.3.5.21. SDMMC2 Clock Register (Default Value: 0x00000000)

Offset: 0x0090			Register Name: <b>SDMMC2_CLK_REG</b>
Bit	R/W	Default/Hex	Description
31	R/W	0x0	SCLK_GATING. Gating Special Clock(Max Clock = 200MHz) 0: Clock is OFF 1: Clock is ON. If SDMMC2 is in old mode, SCLK = Clock Source/Divider N/Divider M. If SDMMC2 is in new mode, SCLK= Clock Source/Divider N/Divider M/2.
30	R/W	0x0	MMC2_MODE_SELECT. 0: Old Mode 1: New Mode.
29:26	/	/	/
25:24	R/W	0x0	CLK_SRC_SEL. Clock Source Select 00: OSC24M 01: PLL_PERIPH0 10: PLL_PERIPH1 11: /
23	/	/	/
22:20	R/W	0x0	CLK_PHASE_CTR.

			Sample Clock Phase Control. The sample clock phase delay is based on the number of source clock that is from 0 to 7.
19:18	/	/	/
17:16	R/W	0x0	CLK_DIV_RATIO_N. Clock Pre Divide Ratio (n) 00: /1 01: /2 10: /4 11: /8.
15:11	/	/	/
10:8	R/W	0x0	OUTPUT_CLK_PHASE_CTR. Output Clock Phase Control. The output clock phase delay is based on the number of source clock that is from 0 to 7.
7:4	/	/	/
3:0	R/W	0x0	CLK_DIV_RATIO_M. Clock Divide Ratio (m) The pre-divided clock is divided by (m+1). The divider M is from 1 to 16.

#### 4.3.5.22. CE Clock Register (Default Value: 0x00000000)

Offset: 0x009C			Register Name: CE_CLK_REG
Bit	R/W	Default/Hex	Description
31	R/W	0x0	SCLK_GATING. Gating Special Clock(Max Clock = 200MHz) 0: Clock is OFF 1: Clock is ON. SCLK = Clock Source/Divider N/Divider M.
30:26	/	/	/
25:24	R/W	0x0	CLK_SRC_SEL. Clock Source Select 00: OSC24M 01: PLL_PERIPH0 10: / 11: /
23:18	/	/	/
17:16	R/W	0x0	CLK_DIV_RATIO_N. Clock Pre Divide Ratio (n) 00: /1 01: /2 10: /4 11: /8.
15:4	/	/	/

3:0	R/W	0x0	CLK_DIV_RATIO_M. Clock divide ratio (m) The pre-divided clock is divided by (m+1). The divider M is from 1 to 16.
-----	-----	-----	---

#### 4.3.5.23. SPI0 Clock Register (Default Value: 0x00000000)

Offset: 0x00A0			Register Name: <b>SPI0_CLK_REG</b>
Bit	R/W	Default/Hex	Description
31	R/W	0x0	SCLK_GATING. Gating Special Clock(Max Clock = 200MHz) 0: Clock is OFF 1: Clock is ON. SCLK = Clock Source/Divider N/Divider M.
30:26	/	/	/
25:24	R/W	0x0	CLK_SRC_SEL. Clock Source Select 00: OSC24M 01: PLL_PERIPH0 10: PLL_PERIPH1 11: /
23:18	/	/	/
17:16	R/W	0x0	CLK_DIV_RATIO_N. Clock Pre Divide Ratio (n) 00: /1 01: /2 10: /4 11: /8.
15:4	/	/	/
3:0	R/W	0x0	CLK_DIV_RATIO_M. Clock Divide Ratio (m) The pre-divided clock is divided by (m+1). The divider M is from 1 to 16.

#### 4.3.5.24. USBPHY Configuration Register (Default Value: 0x00000000)

Offset: 0x00CC			Register Name: <b>USBPHY_CFG_REG</b>
Bit	R/W	Default/Hex	Description
31:17	/	/	/
16	R/W	0x0	SCLK_GATING_OTG_OHCI0. Gating Special Clock For USB OTG_OHCI0 0: Clock is OFF 1: Clock is ON
15:9	/	/	/

8	R/W	0x0	SCLK_GATING_USBPHY0. Gating Special Clock For USB PHY0 0: Clock is OFF 1: Clock is ON
7:1	/	/	/
0	R/W	0x0	USBPHY0_RST. USB PHY0 Reset Control 0: Assert 1: De-assert

#### 4.3.5.25. DRAM Configuration Register (Default Value: 0x00000001)

Offset: 0x00F4			Register Name: <b>DRAM_CFG_REG</b>
Bit	R/W	Default/Hex	Description
31	R/W	0x0	DRAM_CTR_RST. DRAM Controller Reset For AHB Clock Domain. 0: Assert 1: De-assert.
30:22	/	/	/
21:20	R/W	0x0	CLK_SRC_SEL. 00: PLL_DDR0 01: PLL_DDR1 10: PLL_PERIPH0 (2X) 11: /
19:17	/	/	/
16	R/W	0x0	SDRCLK_UPD. SDRCLK Configuration Update. 0:Invalid 1:Valid. Note: Set this bit will validate Configuration 0 . It will be auto cleared after the Configuration 0 is valid. The DRAMCLK Source is from PLL_DDR.
15:4	/	/	/
3:0	R/W	0x1	DRAM_DIV_M. DRAMCLK Divider of Configuration. The clock is divided by (m+1). The divider M should be from 2 to 16.

#### 4.3.5.26. PLL\_DDR1 Configuration Register (Default Value: 0x00000030)

Offset: 0x00F8			Register Name: <b>PLL_DDR_CFG_REG</b>
Bit	R/W	Default/Hex	Description
31:13	/	/	/

12	R/W	0x0	PLL_DDR1_MODE. 0: Normal Mode 1: Continuously Frequency Scale
11:7	/	/	/
6:4	R/W	0x3	PLL_DDR1_PHASE_COMPENSATE. The value of bit[6:4] is based on 24M clock, then the default PLL_DDR phase compensate is (3/24000000) s.
3:0	R/W	0x0	PLL_DDR1_STEP. 0000: 0.004MHz/us (576/2 <sup>17</sup> ) 0001: 0.008MHz/us (576/2 <sup>16</sup> ) 0010: 0.016MHz/us (576/2 <sup>15</sup> ) 0011: 0.032MHz/us (576/2 <sup>14</sup> ) 0100: 0.064MHz/us (576/2 <sup>13</sup> ) 0101: 0.128MHz/us (576/2 <sup>12</sup> ) 0110: 0.256MHz/us (576/2 <sup>11</sup> ) 0111: 0.512MHz/us (576/2 <sup>10</sup> ) 1000: 1.024MHz/us (576/2 <sup>9</sup> ) 1001: 2.048MHz/us (576/2 <sup>8</sup> ) Others: 0.004MHz/us (576/2 <sup>17</sup> )

#### 4.3.5.27. MBUS Reset Register (Default Value: 0x80000000)

Offset: 0x00FC			Register Name: <b>MBUS_RST_REG</b>
Bit	R/W	Default/Hex	Description
31	R/W	0x1	MBUS_RESET. 0: Reset Mbus Domain 1: Assert Mbus Domain.
30:0	/	/	/

#### 4.3.5.28. DRAM Clock Gating Register (Default Value: 0x00000000)

Offset: 0x0100			Register Name: <b>DRAM_CLK_GATING_REG</b>
Bit	R/W	Default/Hex	Description
31:19	/	/	/
18	R/W	0x0	USB_OTG_OHCI_DCLK_GATING. Gating DRAM Clock For USB_OTG_OHCI 0: Mask 1: Pass
17	R/W	0x0	USB_OTG_EHCI_DCLK_GATING. Gating DRAM Clock For USB_OTG_EHCI 0: Mask 1: Pass

16:2	/	/	/
1	R/W	0x0	CSI_DCLK_GATING. Gating DRAM Clock For CSI 0: Mask 1: Pass
0	R/W	0x0	VE_DCLK_GATING. Gating DRAM Clock For VE 0: Mask 1: Pass

#### 4.3.5.29. DE Clock Gating Register (Default Value: 0x00000000)

Offset: 0x0104			Register Name: <b>DE_CLK_REG</b>
Bit	R/W	Default/Hex	Description
31	R/W	0x0	SCLK_GATING. Gating Special Clock 0: Clock is OFF 1: Clock is ON This special clock = Clock Source/Divider M.
30:27	/	/	/
26:24	R/W	0x0	CLK_SRC_SEL. Clock Source Select 000: PLL_VIDEO 010: PLL_PERIPH0 Others: /
23:4	/	/	/
3:0	R/W	0x0	CLK_DIV_RATIO_M. Clock Divide Ratio (m) The pre-divided clock is divided by (m+1). The divider is from 1 to 16.

#### 4.3.5.30. TCON Clock Register (Default Value: 0x00000000)

Offset: 0x0118			Register Name: <b>TCON_CLK_REG</b>
Bit	R/W	Default/Hex	Description
31	R/W	0x0	SCLK_GATING. Gating Special Clock 0: Clock is OFF 1: Clock is ON This special clock = Clock Source/Divider M.
30:27	/	/	/
26:24	R/W	0x0	CLK_SRC_SEL. Clock Source Select

			000: PLL_VIDEO 001: PLL_PERIPH0 Others: /
23:4	/	/	/
3:0	R/W	0x0	CLK_DIV_RATIO_M. Clock Divide Ratio (m) The pre-divided clock is divided by (m+1). The divider is from 1 to 16.

#### 4.3.5.31. CSIO Clock Register (Default Value: 0x00000000)

Offset: 0x0130			Register Name: <b>CSIO_CLK_REG</b>
Bit	R/W	Default/Hex	Description
31	R/W	0x0	CSI_MISC_SCLK_GATING. Gating Special Clock 0: Clock is OFF 1: Clock is ON SCLK = OSC24M.
30:16	/	/	/
15	R/W	0x0	CSIO_MCLK_GATING. Gating Master Clock 0: Clock is OFF 1: Clock is ON SCLK =CSIO Master Clock Source/ CSIO_MCLK_DIV_M.
14:11	/	/	/
10:8	R/W	0x0	CSIO_MCLK_SRC_SEL. CSIO Master Clock Source Select 000: OSC24M 001: PLL_VIDEO 010: PLL_PERIPH1 011: PLL_PERIPH0 Others: /
7:5	/	/	/
4:0	R/W	0x0	CSIO_MCLK_DIV_M. CSIO Master Clock Divide Ratio (m) The pre-divided clock is divided by (m+1). The divider is from 1 to 32.

#### 4.3.5.32. CSI1 Clock Register (Default Value: 0x00000000)

Offset: 0x0134			Register Name: <b>CSI1_CLK_REG</b>
Bit	R/W	Default/Hex	Description
31	R/W	0x0	CSI_TOP_SCLK_GATING. Gating Special Clock



			0: Clock is OFF 1: Clock is ON SCLK = Special Clock Source/CSI_SCLK_DIV_M.
30:27	/	/	/
26:24	R/W	0x0	SCLK_SRC_SEL. Special Clock Source Select 000: PLL_VIDEO 001: PLL_ISP Others: /
23:20	/	/	/
19:16	R/W	0x0	CSI_SCLK_DIV_M. CSI Clock Divide Ratio (m) The pre-divided clock is divided by (m+1). The divider is from 1 to 16.
15	R/W	0x0	CSI1_MCLK_GATING. Gating Master Clock 0: Clock is OFF 1: Clock is ON SCLK =CSI1 Master Clock Source/ CSI1_MCLK_DIV_M.
14:11	/	/	/
10:8	R/W	0x0	CSI1_MCLK_SRC_SEL. CSI1 Master Clock Source Select 000: OSC24M 001: PLL_VIDEO 010: PLL_PERIPH1 011: PLL_PERIPH0 Others: /
7:5	/	/	/
4:0	R/W	0x0	CSI1_MCLK_DIV_M. CSI1 Master Clock Divide Ratio (m) The pre-divided clock is divided by (m+1). The divider is from 1 to 32.

#### 4.3.5.33. VE Clock Register (Default Value: 0x00000000)

Offset: 0x013C			Register Name: <b>VE_CLK_REG</b>
Bit	R/W	Default/Hex	Description
31	R/W	0x0	VE_SCLK_GATING. Gating Special Clock 0: Clock is OFF 1: Clock is ON. SCLK = PLL_VE /Divider N.
30:19	/	/	/.
18:16	R/W	0x0	CLK_DIV_RATIO_N. Clock Pre Divide Ratio (N) The select clock source is pre-divided by n+1. The divider N is from 1 to 8.

15:0	/	/	/
------	---	---	---

**4.3.5.34. AC Digital Clock Register (Default Value: 0x00000000)**

Offset: 0x0140			Register Name: <b>AC_DIG_CLK_REG</b>
Bit	R/W	Default/Hex	Description
31	R/W	0x0	SCLK_1X_GATING. Gating Special Clock 0: Clock is OFF 1: Clock is ON SCLK = PLL_AUDIO Output.
30:0	/	/	/

**4.3.5.35. AVS Clock Register (Default Value: 0x00000000)**

Offset: 0x0144			Register Name: <b>AVS_CLK_REG</b>
Bit	R/W	Default/Hex	Description
31	R/W	0x0	SCLK_GATING. Gating Special Clock 0: Clock is OFF 1: Clock is ON. SCLK= OSC24M.
30:0	/	/	/

**4.3.5.36. MBUS Clock Register (Default Value: 0x00000000)**

Offset: 0x015C			Register Name: <b>MBUS_CLK_REG</b>
Bit	R/W	Default/Hex	Description
31	R/W	0x0	MBUS_SCLK_GATING. Gating Clock for MBUS 0: Clock is OFF 1: Clock is ON. MBUS_CLOCK = Clock Source/Divider M
30:26	/	/	/
25:24	R/W	0x0	MBUS_SCLK_SRC Clock Source Select 00: OSC24M 01: PLL_PERIPH0(2X) 10: PLL_DDR0 11: /.
23:3	/	/	/

2:0	R/W	0x0	<b>MBUS_SCLK_RATIO_M</b> Clock Divide Ratio (m) The pre-divided clock is divided by (m+1). The divider M is from 1 to 8. The divide ratio must be changed smoothly. Note: If the clock has been changed ,it must wait for at least 16 cycles.
-----	-----	-----	---

**4.3.5.37. MIPI\_CSI Register (Default Value: 0x00000000)**

Offset: 0x016C			Register Name: <b>MIPI_CSI_REG</b>
Bit	R/W	Default/Hex	Description
31	R/W	0x0	<b>MIPICSI2_DPHY_CLK_GATING.</b> Gating Clock For CSI_DPHY 0: Clock is OFF 1: Clock is ON SCLK= Clock Source/Divider M
30:26	/	/	/
25:24	R/W	0x0	<b>CLK_SRC_SEL.</b> Clock Source Select 00: PLL_VIDEO 01: PLL_PERIPH0 10: PLL_ISP 11: /
23:3	/	/	/
3:0	R/W	0x0	<b>CLK_DIV_RATIO_M.</b> Clock divide ratio (m) The pre-divided clock is divided by (m+1). The divider is from 1 to 16.

**4.3.5.38. PLL Stable Time Register0 (Default Value: 0x000000FF)**

Offset: 0x0200			Register Name: <b>PLL_STABLE_TIME_REG0</b>
Bit	R/W	Default/Hex	Description
31:16	/	/	/
15:0	R/W	0x00FF	<b>PLL_LOCK_TIME</b> PLL Lock Time (Unit: us). Note: When any PLL (except PLL_CPU) is enabled or changed, the corresponding PLL lock bit will be set after the PLL STABLE Time.

**4.3.5.39. PLL Stable Time Register1 (Default Value: 0x000000FF)**

Offset: 0x0204			Register Name: <b>PLL_STABLE_TIME_REG1</b>
Bit	R/W	Default/Hex	Description

31:16	/	/	/
15:0	R/W	0x00FF	PLL_CPU_LOCK_TIME PLL_CPU Lock Time (Unit: us). Note: When PLL_CPU is enabled or changed, the PLL_CPU lock bit will be set after the PLL_CPU STABLE Time.

#### 4.3.5.40. PLL\_CPUX Bias Register (Default Value: 0x08100200)

Offset: 0x0220			Register Name: PLL_CPUX_BIAS_REG
Bit	R/W	Default/Hex	Description
31	R/W	0x0	VCO_RST. VCO reset in.
30:29	/	/	/
28	R/W	0x0	EXG_MODE. Exchange Mode. Note: CPU PLL source will select PLL_PERIPH0 instead of PLL_CPU
27:24	R/W	0x8	PLL_VCO_BIAS_CTRL. PLL VCO Bias Control[3:0].
23:21	/	/	/
20:16	R/W	0x10	PLL_BIAS_CUR_CTRL. PLL Bias Current Control[4:0].
15:11	/	/	/
10:8	R/W	0x2	PLL_LOCK_CTRL. PLL Lock Time Control[2:0].
7:4	/	/	/
3:0	R/W	0x0	PLL_DAMP_FACT_CTRL. PLL Damping Factor Control[3:0].

#### 4.3.5.41. PLL\_AUDIO Bias Register (Default Value: 0x10100000)

Offset: 0x0224			Register Name: PLL_AUDIO_BIAS_REG
Bit	R/W	Default/Hex	Description
31:29	/	/	/
28:24	R/W	0x10	PLL_VCO_BIAS. PLL VCO Bias Current[4:0].
23:21	/	/	/
20:16	R/W	0x10	PLL_BIAS_CUR. PLL Bias Current[4:0].
15:0	/	/	/

**4.3.5.42. PLL\_VIDEO Bias Register (Default Value: 0x10100000)**

Offset: 0x0228			Register Name: <b>PLL_VIDEO_BIAS_REG</b>
Bit	R/W	Default/Hex	Description
31:29	/	/	/
28:24	R/W	0x10	PLL_VCO_BIAS_CTRL. PLL VCO Bias Control[4:0].
23:21	/	/	/
20:16	R/W	0x10	PLL_BIAS_CTRL. PLL Bias Control[4:0].
15:3	/	/	/
2:0	R/W	0x0	PLL_DAMP_FACTOR_CTRL. PLL Damping Factor Control[2:0].

**4.3.5.43. PLL\_VE Bias Register (Default Value: 0x10100000)**

Offset: 0x022C			Register Name: <b>PLL_VE_BIAS_REG</b>
Bit	R/W	Default/Hex	Description
31:29	/	/	/
28:24	R/W	0x10	PLL_VCO_BIAS_CTRL. PLL VCO Bias Control[4:0].
23:21	/	/	/
20:16	R/W	0x10	PLL_BIAS_CTRL. PLL Bias Control[4:0].
15:3	/	/	/
2:0	R/W	0x0	PLL_DAMP_FACTOR_CTRL. PLL Damping Factor Control[2:0].

**4.3.5.44. PLL\_DDR0 Bias Register (Default Value: 0x81104000)**

Offset: 0x0230			Register Name: <b>PLL_DDR0_BIAS_REG</b>
Bit	R/W	Default/Hex	Description
31:28	R/W	0x8	PLL_VCO_BIAS. PLL VCO Bias[3:0].
27:26	/	/	/.
25	R/W	0x0	PLL_VCO_GAIN_CTRL_EN. PLL VCO Gain Control Enable. 0: Disable 1: Enable.
24	R/W	0x1	PLL_BANDW_CTRL. PLL Band Width Control.

			0: Narrow 1: Wide.
23:21	/	/	/
20:16	R/W	0x10	PLL_BIAS_CUR_CTRL. PLL Bias Current Control.
15	/	/	/
14:12	R/W	0x4	PLL_VCO_GAIN_CTRL. PLL VCO Gain Control Bit[2:0].
11:4	/	/	/
3:0	R/W	0x0	PLL_DAMP_FACTOR_CTRL. PLL Damping Factor Control[3:0].

#### 4.3.5.45. PLL\_PERIPH0 Bias Register (Default Value: 0x10100010)

Offset: 0x0234			Register Name: <b>PLL_PERIPH0_BIAS_REG</b>
Bit	R/W	Default/Hex	Description
31:29	/	/	/
28:24	R/W	0x10	PLL_VCO_BIAS. PLL VCO Bias[4:0].
23:21	/	/	/
20:16	R/W	0x10	PLL_BIAS_CUR_CTRL. PLL Bias Current Control.
15:5	/	/	/
4	R/W	0x1	PLL_BANDW_CTRL. PLL Band Width Control. 0: Narrow 1: Wide
3:2	/	/	/
1:0	R/W	0x0	PLL_DAMP_FACTOR_CTRL. PLL Damping Factor Control[1:0].

#### 4.3.5.46. PLL\_ISP Bias Register (Default Value: 0x10100000)

Offset: 0x0238			Register Name: <b>PLL_ISP_BIAS_REG</b>
Bit	R/W	Default/Hex	Description
31:29	/	/	/
28:24	R/W	0x10	PLL_VCO_BIAS_CTRL. PLL VCO Bias Control[4:0].
23:21	/	/	/
20:16	R/W	0x10	PLL_BIAS_CTRL. PLL Bias Control[4:0].
15:3	/	/	/

2:0	R/W	0x0	PLL_DAMP_FACTOR_CTRL. PLL Damping Factor Control[2:0].
-----	-----	-----	---

**4.3.5.47. PLL\_PERIPH1 Bias Register (Default Value: 0x10100010)**

Offset: 0x0244			Register Name: <b>PLL_PERIPH1_BIAS_REG</b>
Bit	R/W	Default/Hex	Description
31:29	/	/	/
28:24	R/W	0x10	PLL_VCO_BIAS. PLL VCO Bias[4:0].
23:21	/	/	/
20:16	R/W	0x10	PLL_BIAS_CUR_CTRL. PLL Bias Current Control.
15:5	/	/	/
4	R/W	0x1	PLL_BANDW_CTRL. PLL Band Width Control. 0: Narrow 1: Wide
3:2	/	/	/
1:0	R/W	0x0	PLL_DAMP_FACTOR_CTRL. PLL Damping Factor Control[1:0].

**4.3.5.48. PLL\_DDR1 Bias Register (Default Value: 0x10010000)**

Offset: 0x024C			Register Name: <b>PLL_DDR1_BIAS_REG</b>
Bit	R/W	Default/Hex	Description
31:29	/	/	/
28:24	R/W	0x10	PLL_VCO_BIAS_CTRL. PLL VCO Bias Control[4:0].
23:21	/	/	/
20:16	R/W	0x01	PLL_BIAS_CUR_CTRL. PLL Bias Current Control[4:0].
15:0	/	/	/

**4.3.5.49. PLL\_CPU Tuning Register (Default Value: 0x0A101000)**

Offset: 0x0250			Register Name: <b>PLL_CPU_TUN_REG</b>
Bit	R/W	Default/Hex	Description
31:28	/	/	/
27	R/W	0x1	PLL_BAND_WID_CTRL. PLL Band Width Control.

			0: Narrow 1: Wide
26	R/W	0x0	VCO_GAIN_CTRL_EN. VCO Gain Control Enable. 0: Disable 1: Enable
25:23	R/W	0x4	VCO_GAIN_CTRL. VCO Gain Control Bits[2:0].
22:16	R/W	0x10	PLL_INIT_FREQ_CTRL. PLL Initial Frequency Control[6:0].
15	R/W	0x0	C_OD. C-Reg-Od For Verify.
14:8	R/W	0x10	C_B_IN. C-B-In[6:0] For Verify.
7	R/W	0x0	C_OD1. C-Reg-Od1 For Verify.
6:0	R	0x0	C_B_OUT. C-B-Out[6:0] For Verify.

#### 4.3.5.50. PLL\_DDR0 Tuning Register (Default Value: 0x14880000)

Offset: 0x0260			Register Name: PLL_DDR0_TUN_REG
Bit	R/W	Default/Hex	Description
31:29	/	/	/
28	R/W	0x1	VREG1_OUT_EN. Vreg1 Out Enable. 0: Disable 1: Enable
27	/	/	/
26:24	R/W	0x4	PLL_LTIME_CTRL. PLL Lock Time Control[2:0].
23	R/W	0x1	VCO_RST. VCO Reset In.
22:16	R/W	0x08	PLL_INIT_FREQ_CTRL. PLL Initial Frequency Control[6:0].
15	R/W	0x0	OD1. Reg-Od1 For Verify.
14:8	R/W	0x0	B_IN. B-In[6:0] For Verify.
7	R/W	0x0	OD. Reg-Od For Verify.
6:0	R	0x0	B_OUT. B-Out[6:0] For Verify.



**4.3.5.51. PLL\_CPU Pattern Control Register (Default Value: 0x00000000)**

Offset: 0x0280			Register Name: PLL_CPU_PAT_CTRL_REG
Bit	R/W	Default/Hex	Description
31	R/W	0x0	SIG_DELT_PAT_EN. Sigma-delta Pattern Enable.
30:29	R/W	0x0	SPR_FREQ_MODE. Spread Frequency Mode. 00: DC=0 01: DC=1 1X: Triangular
28:20	R/W	0x0	WAVE_STEP. Wave Step.
19	/	/	/
18:17	R/W	0x0	FREQ. Frequency. 00: 31.5KHz 01: 32KHz 10: 32.5KHz 11: 33KHz
16:0	R/W	0x0	WAVE_BOT. Wave Bottom.

**4.3.5.52. PLL\_AUDIO Pattern Control Register(Default Value: 0x00000000)**

Offset: 0x0284			Register Name: PLL_AUDIO_PAT_CTRL_REG
Bit	R/W	Default/Hex	Description
31	R/W	0x0	SIG_DELT_PAT_EN. Sigma-delta Pattern Enable.
30:29	R/W	0x0	SPR_FREQ_MODE. Spread Frequency Mode. 00: DC=0 01: DC=1 1X: Triangular
28:20	R/W	0x0	WAVE_STEP. Wave Step.
19	/	/	/
18:17	R/W	0x0	FREQ. Frequency. 00: 31.5KHz 01: 32KHz 10: 32.5KHz 11: 33KHz

16:0	R/W	0x0	WAVE_BOT. Wave Bottom.
------	-----	-----	---------------------------

**4.3.5.53. PLL\_VIDEO Pattern Control Register (Default Value: 0x00000000)**

Offset: 0x0288			Register Name: PLL_VIDEO_PAT_CTRL_REG
Bit	R/W	Default/Hex	Description
31	R/W	0x0	SIG_DELT_PAT_EN. Sigma-delta Pattern Enable.
30:29	R/W	0x0	SPR_FREQ_MODE. Spread Frequency Mode. 00: DC=0 01: DC=1 1X: Triangular
28:20	R/W	0x0	WAVE_STEP. Wave Step.
19	/	/	/
18:17	R/W	0x0	FREQ. Frequency. 00: 31.5KHz 01: 32KHz 10: 32.5KHz 11: 33KHz
16:0	R/W	0x0	WAVE_BOT. Wave Bottom.

**4.3.5.54. PLL\_VE Pattern Control Register (Default Value: 0x00000000)**

Offset: 0x028C			Register Name: PLL_VE_PAT_CTRL_REG
Bit	R/W	Default/Hex	Description
31	R/W	0x0	SIG_DELT_PAT_EN. Sigma-delta Pattern Enable.
30:29	R/W	0x0	SPR_FREQ_MODE. Spread Frequency Mode. 00: DC=0 01: DC=1 1X: Triangular
28:20	R/W	0x0	WAVE_STEP. Wave Step.
19	/	/	/
18:17	R/W	0x0	FREQ. Frequency.

			00: 31.5KHz 01: 32KHz 10: 32.5KHz 11: 33KHz
16:0	R/W	0x0	WAVE_BOT. Wave Bottom.

#### 4.3.5.55. PLL\_DDR0 Pattern Control Register (Default Value: 0x00000000)

Offset: 0x0290			Register Name: <b>PLL_DDR0_PAT_CTRL_REG</b>
Bit	R/W	Default/Hex	Description
31	R/W	0x0	SIG_DELT_PAT_EN. Sigma-delta Pattern Enable.
30:29	R/W	0x0	SPR_FREQ_MODE. Spread Frequency Mode. 00: DC=0 01: DC=1 1X: Triangular
28:20	R/W	0x0	WAVE_STEP. Wave step.
19	/	/	/
18:17	R/W	0x0	FREQ. Frequency. 00: 31.5KHz 01: 32KHz 10: 32.5KHz 11: 33KHz
16:0	R/W	0x0	WAVE_BOT. Wave Bottom.

#### 4.3.5.56. PLL\_ISP Pattern Control Register (Default Value: 0x00000000)

Offset: 0x0298			Register Name: <b>PLL_ISP_PAT_CTRL_REG</b>
Bit	R/W	Default/Hex	Description
31	R/W	0x0	SIG_DELT_PAT_EN. Sigma-delta Pattern Enable.
30:29	R/W	0x0	SPR_FREQ_MODE. Spread Frequency Mode. 00: DC=0 01: DC=1 1X: Triangular
28:20	R/W	0x0	WAVE_STEP.

			Wave step.
19	/	/	/
18:17	R/W	0x0	FREQ. Frequency. 00: 31.5KHz 01: 32KHz 10: 32.5KHz 11: 33KHz
16:0	R/W	0x0	WAVE_BOT. Wave Bottom.

#### 4.3.5.57. PLL\_PERIPH1 Pattern Control Register (Default Value: 0x00000000)

Offset: 0x02A4			Register Name: <b>PLL_PERIPH1_PAT_CTRL_REG</b>
Bit	R/W	Default/Hex	Description
31	R/W	0x0	SIG_DELT_PAT_EN. Sigma-Delta Pattern Enable.
30:29	R/W	0x0	SPR_FREQ_MODE. Spread Frequency Mode. 00: DC=0 01: DC=1 1X: Triangular
28:20	R/W	0x0	WAVE_STEP. Wave Step.
19	/	/	/
18:17	R/W	0x0	FREQ. Frequency. 00: 31.5KHz 01: 32KHz 10: 32.5KHz 11: 33KHz
16:0	R/W	0x0	WAVE_BOT. Wave Bottom.

#### 4.3.5.58. PLL\_DDR1 Pattern Control Register (Default Value: 0x00000000)

Offset: 0x02AC			Register Name: <b>PLL_DDR1_PAT_CTRL_REG0</b>
Bit	R/W	Default/Hex	Description
31	R/W	0x0	SIG_DELT_PAT_EN. Sigma-Delta Pattern Enable.
30:29	R/W	0x0	SPR_FREQ_MODE. Spread Frequency Mode.

			00: DC=0 01: DC=1 1X: Triangular
28:20	R/W	0x0	WAVE_STEP. Wave Step.
19	/	/	/
18:17	R/W	0x0	FREQ. Frequency. 00: 31.5KHz 01: 32KHz 10: 32.5KHz 11: 33KHz
16:0	R/W	0x0	WAVE_BOT. Wave Bottom.

#### 4.3.5.59. PLL\_DDR1 Pattern Control Register1 (Default Value: 0x00000000)

Offset: 0x02B0			Register Name: <b>PLL_DDR1_PAT_CTRL_REG1</b>
Bit	R/W	Default/Hex	Description
30:25	/	/	/
24	R/W	0x0	DITHER_EN.
23:21	/	/	/
20	R/W	0x0	FRAC_EN.
19:17	/	/	/
16:0	R/W	0x0	FRAC_IN.

#### 4.3.5.60. Bus Software Reset Register 0 (Default Value: 0x00000000)

Offset: 0x02C0			Register Name: <b>BUS_SOFT_RST_REG0</b>
Bit	R/W	Default/Hex	Description
31:30	/	/	/
29	R/W	0x0	USB OTG_OHCI_RST. USB OTG_OHCI Reset Control 0: Assert 1: De-assert
27:28	/	/	/
26	R/W	0x0	USB OTG_EHCI_RST. USB OTG_EHCI Reset Control 0: Assert 1: De-assert
25	/	/	/
24	R/W	0x0	USB OTG_Device_RST.

			USB OTG_Device Reset Control 0: Assert 1: De-assert
23:21	/	/	/
20	R/W	0x0	SPIO_RST. SPIO Reset. 0: Assert 1: De-assert
19	R/W	0x0	HSTMR_RST. HSTMR Reset. 0: Assert 1: De-assert
18	/	/	/
17	R/W	0x0	EMAC_RST. EMAC Reset. 0: Assert 1: De-assert
16:15	/	/	/
14	R/W	0x0	SDRAM_RST. SDRAM AHB Reset. 0: Assert 1: De-assert
13:11	/	/	/
10	R/W	0x0	SD2_RST. SD/MMC2 Reset. 0: Assert 1: De-assert
9	R/W	0x0	SD1_RST. SD/MMC1 Reset. 0: Assert 1: De-assert
8	R/W	0x0	SD0_RST. SD/MMC0 Reset. 0: Assert 1: De-assert
7	/	/	/
6	R/W	0x0	DMA_RST. DMA Reset. 0: Assert 1: De-assert
5	R/W	0x0	CE_RST. CE Reset. 0: Assert 1: De-assert
4:0	/	/	/

**4.3.5.61. Bus Software Reset Register 1 (Default Value: 0x00000000)**

Offset: 0x02C4			Register Name: <b>BUS_SOFT_RST_REG1</b>
Bit	R/W	Default/Hex	Description
31	R/W	0x0	DBGSYS_RST. DBGSYS Reset 0: Assert 1: De-assert
30:13	/	/	/
12	R/W	0x0	DE_RST. DE Reset. 0: Assert 1: De-assert
11:9	/	/	/
8	R/W	0x0	CSI_RST. CSI Reset. 0: Assert 1: De-assert
7:5	/	/	/
4	R/W	0x0	TCON_RST. TCON Reset. 0: Assert 1: De-assert
3:1	/	/	/
0	R/W	0x0	VE_RST. VE Reset. 0: Assert 1: De-assert

**4.3.5.62. Bus Software Reset Register 2 (Default Value: 0x00000000)**

Offset: 0x02C8			Register Name: <b>BUS_SOFT_RST_REG2</b>
Bit	R/W	Default/Hex	Description
31:3	/	/	/
2	R/W	0x0	EPHY_RST. EPHY Reset. 0: Assert 1: De-assert
1	/	/	/
0	R/W	0x0	/

**4.3.5.63. Bus Software Reset Register 3 (Default Value: 0x00000000)**

Offset: 0x02D0			Register Name: <b>BUS_SOFT_RST_REG3</b>
Bit	R/W	Default/Hex	Description
31:13	/	/	/
12	R/W	0x0	/
11:1	/	/	/
0	R/W	0x0	AC_DIG_RST. AC Digital Reset. 0: Assert 1: De-assert

**4.3.5.64. Bus Software Reset Register 4 (Default Value: 0x00000000)**

Offset: 0x02D8			Register Name: <b>BUS_SOFT_RST_REG4</b>
Bit	R/W	Default/Hex	Description
31:19	/	/	/
18	R/W	0x0	UART2_RST. UART2 Reset. 0: Assert 1: De-assert
17	R/W	0x0	UART1_RST. UART1 Reset. 0: Assert 1: De-assert
16	R/W	0x0	UART0_RST. UART0 Reset. 0: Assert 1: De-assert
15:2	/	/	/
1	R/W	0x0	TWI1_RST. TWI1 Reset. 0: Assert 1: De-assert
0	R/W	0x0	TWI0_RST. TWI0 Reset. 0: Assert 1: De-assert

**4.3.5.65. PS Control Register (Default Value: 0x00000000)**

Offset: 0x0300		Register Name: <b>PS_CTRL_REG</b>
----------------	--	-----------------------------------



Bit	R/W	Default/Hex	Description
31:8	/	/	/
7	R/W	0x0	DET_FIN. Detect Finish. 0: Unfinished 1: Finished Set 1 to this bit will clear it.
6	R/W	0x0	DLY_SEL. Delay Select 0: 1 Cycle 1: 2 Cycles
5:4	R/W	0x0	OSC_SEL OSC Select. 00: IDLE 01: SVT 10: LVT 11: ULVT
3:1	R/W	0x0	TIME_DET. Time detect. 000: 0.5/4 us 001: 0.5/2 us 002: 0.5/1 us 003: 0.5*2us ..... 111:0.5*2 <sup>5</sup> us
0	R/W	0x0	MOD_EN. Module enable. 0: Disable 1: Enable

#### 4.3.5.66. PS Counter Register (Default Value: 0x00000000)

Offset: 0x0304			Register Name: PS_CNT_REG
Bit	R/W	Default/Hex	Description
31:16	/	/	/
15:0	R/W	0x0	PS_CNT. PS Counter.

### 4.3.6. Programming Guidelines

#### 4.3.6.1. PLL

- 1) In practical application, other PLLs doesn't support dynamic frequency scaling except for PLL\_CPU and PLL\_DDR1;
- 2) After the PLL\_DDR0 frequency changes, the 20-bit of PLL\_DDR0 Control Register should be written 1 to make it valid;
- 3) After the PLL\_DDR1 frequency changes, the 30-bit of PLL\_DDR1 Control Register should be written 1 to make it valid.

#### 4.3.6.2. BUS

- 1) When setting the BUS clock , you should set the division factor first, and after the division factor becomes valid, switch the clock source. The clock source will be switched after at least three clock cycles;
- 2) The BUS clock should not be dynamically changed in most applications.

#### 4.3.6.3. Clock Switch

Make sure that the clock source output is valid before the clock source switch, and then set a proper divide ratio; after the division factor becomes valid, switch the clock source.

#### 4.3.6.4. Gating and reset

Make sure that the reset signal has been released before the release of module clock gating;

## 4.4. System Control

### 4.4.1. Overview

Area	Size(Bytes)
SRAM A1	16K
SRAM C	44K
CPU I-Cache	32K
CPU D-Cache	32K
CPU L2 Cache	128K
Total	252K

### 4.4.2. System Control Register List

Module Name	Base Address
System Control	0x01C00000

Register Name	Offset	Description
VER_REG	0x24	Version Register
EMAC_CLK_REG	0x30	EMAC-EPHY Clock Register

### 4.4.3. System Control Register Description

#### 4.4.3.1. Version Register (Default Value: 0x00000000)

Offset:0x24			Register Name: <b>VER_REG</b>
Bit	R/W	Default/Hex	Description
31:9	/	/	/
8	R	x	UBOOT_SEL_PAD_STA. U_boot Select Pin Status. 0: U_Boot; 1: Normal Boot.
7:0	R	0x0	VER_BITS. This read-only bit field always reads back the mask revision level of the chip.

**4.4.3.2. EMAC-EPHY Clock Register (Default Value: 0x00058000)**

Offset:0x30			Register Name: <b>EMAC_EPHY_CLK_REG</b>
Bit	R/W	Default/Hex	Description
31:28	R/W	0x0	BPS_EFFUSE
27	R/W	0x0	XMII_SEL 0: Internal SMI and MII 1: External SMI and MII
26:25	R/W	0x0	EPHY_MODE Operation Mode Selection 00 : Normal Mode 01 : Sim Mode 10 : AFE Test Mode 11 : /
24:20	R/W	0x0	PHY_ADDR PHY Address
19	R/W	0x0	BIST_CLK_EN 0 : BIST clk disable 1 : BIST clk enable
18	R/W	0x1	CLK_SEL 0 : 25MHz 1 : 24MHz
17	R/W	0x0	LED_POL 0 : High active 1 : Low active
16	R/W	0x1	SHUTDOWN 0 : Power up 1 : Shutdown
15	R/W	0x1	PHY_SELECT. 0 : External PHY 1 : Internal PHY
14	/	/	/
13	R/W	0x0	RMII_EN 0 : Disable RMII Module 1 : Enable RMII Module When this bit assert, MII or RGMII interface is disabled( This means bit13 is prior to bit2)
12:10	R/W	0x0	ETXDC. Configure EMAC Transmit Clock Delay Chain.
9:5	R/W	0x0	ERXDC. Configure EMAC Receive Clock Delay Chain.
4	R/W	0x0	ERXIE Enable EMAC Receive Clock Invertor. 0: Disable

			1: Enable
3	R/W	0x0	ETXIE Enable EMAC Transmit Clock Invertor. 0: Disable 1: Enable
2	R/W	0x0	EPIT EMAC PHY Interface Type 0: MII 1: RGMII
1:0	R/W	0x0	ETCS. EMAC Transmit Clock Source 00: Transmit clock source for MII 01: External transmit clock source for GMII and RGMII 10: Internal transmit clock source for GMII and RGMII 11: Reserved

## 4.5. Timer

### 4.5.1. Overview

Timer 0/1/2 can take their inputs from Internal OSC or OSC24M. They provide the operating system’s scheduler interrupt. It is designed to offer maximum accuracy and efficient management, even for systems with long or short response time. They provide 24-bit programmable overflow counter and work in auto-reload mode or no-reload mode. When the current value in *Current Value Register* is counting down to zero, the timer will generate interrupt if set interrupt enable bit.

The watchdog is used to resume the controller operation when it had been disturbed by malfunctions such as noise and system errors. It features a down counter that allows a watchdog period of up to 16 seconds (512000 cycles). It can generate a general reset or interrupt request.

AVS counter is used to synchronize video and audio in the player.

### 4.5.2. Block Diagram

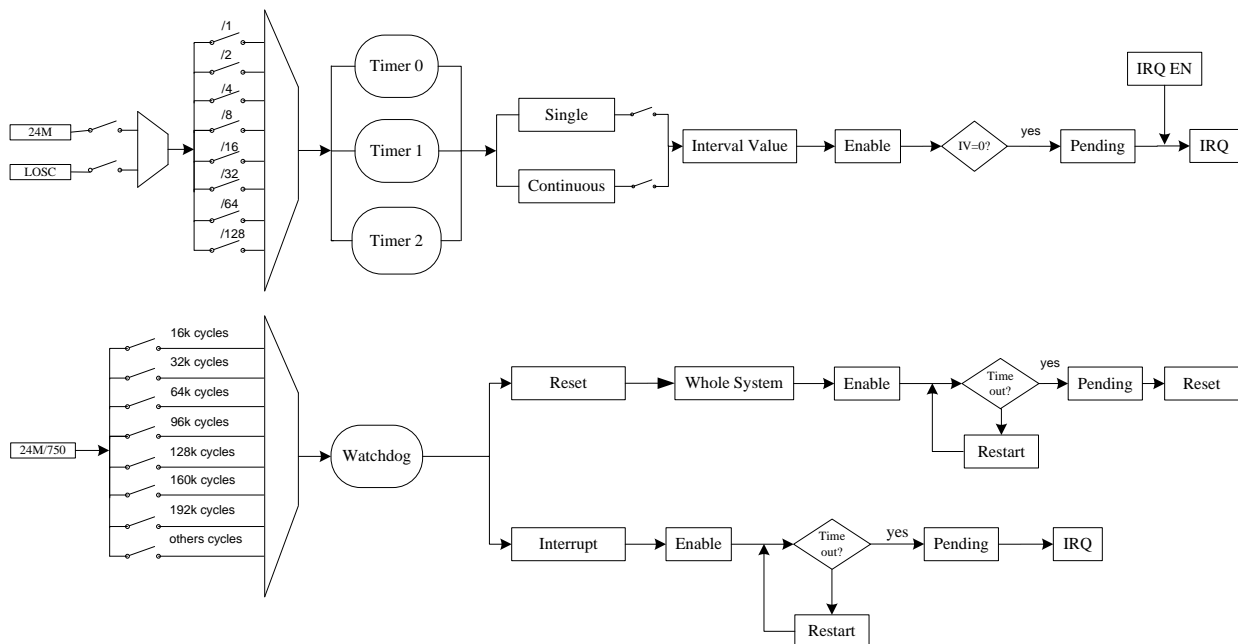

Figure 4-4. Timer Block Diagram

### 4.5.3. Timer Register List

Module Name	Base Address
TIMER	0x01C20C00

Register Name	Offset	Description
TMR_IRQ_EN_REG	0x0	Timer IRQ Enable Register
TMR_IRQ_STA_REG	0x4	Timer Status Register
TMR0_CTRL_REG	0x10	Timer 0 Control Register
TMR0_INTV_VALUE_REG	0x14	Timer 0 Interval Value Register
TMR0_CUR_VALUE_REG	0x18	Timer 0 Current Value Register
TMR1_CTRL_REG	0x20	Timer 1 Control Register
TMR1_INTV_VALUE_REG	0x24	Timer 1 Interval Value Register
TMR1_CUR_VALUE_REG	0x28	Timer 1 Current Value Register
TMR2_CTRL_REG	0x30	Timer 2 Control Register
TMR2_INTV_VALUE_REG	0x34	Timer 2 Interval Value Register
TMR2_CUR_VALUE_REG	0x38	Timer 2 Current Value Register
AVS_CNT_CTL_REG	0x80	AVS Control Register
AVS_CNT0_REG	0x84	AVS Counter 0 Register
AVS_CNT1_REG	0x88	AVS Counter 1 Register
AVS_CNT_DIV_REG	0x8C	AVS Divisor Register
WDOG_IRQ_EN_REG	0xA0	Watchdog IRQ Enable Register
WDOG_IRQ_STA_REG	0xA4	Watchdog Status Register
WDOG_CTRL_REG	0xB0	Watchdog Control Register
WDOG_CFG_REG	0xB4	Watchdog Configuration Register
WDOG_MODE_REG	0xB8	Watchdog Mode Register
CNT64_TEST_REG	0xD0	64-bit Counter Test Mode Register
CNT64_CTRL_REG	0xD4	64-bit Counter Control Register
CNT64_LOW_REG	0xD8	64-bit Counter Low Register
CNT64_HIGH_REG	0xDC	64-bit Counter High Register

### 4.5.4. Timer Register Description

#### 4.5.4.1. Timer IRQ Enable Register (Default Value: 0x00000000)

Offset:0x0			Register Name: <b>TMR_IRQ_EN_REG</b>
Bit	R/W	Default/Hex	Description
31:3	/	/	/
2	R/W	0x0	TMR2_IRQ_EN. Timer 2 Interrupt Enable. 0: No effect; 1: Timer 2 Interval Value reached interrupt enable.

1	R/W	0x0	TMR1_IRQ_EN. Timer 1 Interrupt Enable. 0: No effect; 1: Timer 1 Interval Value reached interrupt enable.
0	R/W	0x0	TMRO_IRQ_EN. Timer 0 Interrupt Enable. 0: No effect; 1: Timer 0 Interval Value reached interrupt enable.

#### 4.5.4.2. Timer IRQ Status Register (Default Value: 0x00000000)

Offset:0x04			Register Name: TMR_IRQ_STA_REG
Bit	R/W	Default/Hex	Description
31:3	/	/	/
2	R/W	0x0	TMR2_IRQ_PEND. Timer 2 IRQ Pending. Set 1 to the bit will clear it. 0: No effect; 1: Pending, timer 2 interval value is reached.
1	R/W	0x0	TMR1_IRQ_PEND. Timer 1 IRQ Pending. Set 1 to the bit will clear it. 0: No effect; 1: Pending, timer 1 interval value is reached.
0	R/W	0x0	TMRO_IRQ_PEND. Timer 0 IRQ Pending. Set 1 to the bit will clear it. 0: No effect; 1: Pending, timer 0 interval value is reached.

#### 4.5.4.3. Timer 0 Control Register (Default Value: 0x00000004)

Offset:0x10			Register Name: TMRO_CTRL_REG
Bit	R/W	Default/Hex	Description
31:8	/	/	/
7	R/W	0x0	TMRO_MODE. Timer 0 mode. 0: Continuous mode. When interval value reached, the timer will not disable automatically. 1: Single mode. When interval value reached, the timer will disable automatically.
6:4	R/W	0x0	TMRO_CLK_PRES. Select the pre-scale of timer 0 clock source. 000: /1 001: /2



			010: /4 011: /8 100: /16 101: /32 110: /64 111: /128
3:2	R/W	0x1	TMRO_CLK_SRC. Timer 0 Clock Source. 00: Internal OSC / 512 01: OSC24M. 10: / 11: / Internal OSC / N is about 32KHz.
1	R/W	0x0	TMRO_RELOAD. Timer 0 Reload. 0: No effect 1: Reload timer 0 Interval value. After the bit is set, it can not be written again before it's cleared automatically.
0	R/W	0x0	TMRO_EN. Timer 0 Enable. 0: Stop/Pause 1: Start. When the timer is started, it will reload the interval value to internal register, and the current counter will count from interval value to 0. If the current counter does not reach the zero, the timer enable bit is set to "0", the current value counter will pause. At least wait for 2 cycles, the start bit can be set to 1. In timer pause state; the interval value register can be modified. If the timer is started again, and the Software hope the current value register to down-count from the new interval value, the reload bit and the enable bit should be set to 1 at the same time.

#### 4.5.4.4. Timer 0 Interval Value Register

Offset:0x14			Register Name: <b>TMRO_INTV_VALUE_REG</b>
Bit	R/W	Default/Hex	Description
31:0	R/W	0x0	TMRO_INTV_VALUE. Timer 0 Interval Value. <b>Note:</b> The value setting should consider the system clock and the timer clock source.

**4.5.4.5. Timer 0 Current Value Register**

Offset:0x18			Register Name: <b>TMR0_CUR_VALUE_REG</b>
Bit	R/W	Default/Hex	Description
31:0	R/W	0x0	TMR0_CUR_VALUE. Timer 0 Current Value. <b>Note:</b> It is a 32-bit down-counter (from interval value to 0).

**4.5.4.6. Timer 1 Control Register (Default Value: 0x00000004)**

Offset:0x20			Register Name: <b>TMR1_CTRL_REG</b>
Bit	R/W	Default/Hex	Description
31:8	/	/	/
7	R/W	0x0	TMR1_MODE. Timer 1 mode. 0: Continuous mode. When interval value reached, the timer will not disable automatically. 1: Single mode. When interval value reached, the timer will disable automatically.
6:4	R/W	0x0	TMR1_CLK_PRES. Select the pre-scale of timer 1 clock source. 000: /1 001: /2 010: /4 011: /8 100: /16 101: /32 110: /64 111: /128
3:2	R/W	0x1	TMR1_CLK_SRC. 00: Internal OSC / 512 01: OSC24M. 10: / 11: /. Internal OSC / N is about 32KHz.
1	R/W	0x0	TMR1_RELOAD. Timer 1 Reload. 0: No effect 1: Reload timer 1 Interval value. After the bit is set, it can not be written again before it's cleared automatically.
0	R/W	0x0	TMR1_EN. Timer 1 Enable.

			<p>0: Stop/Pause 1: Start.</p> <p>If the timer is started, it will reload the interval value to internal register, and the current counter will count from interval value to 0.</p> <p>If the current counter does not reach the zero, the timer enable bit is set to "0", the current value counter will pause. At least wait for 2 cycles, the start bit can be set to 1.</p> <p>In timer pause state, the interval value register can be modified. If the timer is started again, and the Software hope the current value register to down-count from the new interval value, the reload bit and the enable bit should be set to 1 at the same time.</p>
--	--	--	---

**4.5.4.7. Timer 1 Interval Value Register**

Offset:0x24			Register Name: <b>TMR1_INTV_VALUE_REG</b>
Bit	R/W	Default/Hex	Description
31:0	R/W	0x0	<p>TMR1_INTV_VALUE. Timer 1 Interval Value.</p> <p><b>Note:</b>The value setting should consider the system clock and the timer clock source.</p>

**4.5.4.8. Timer 1 Current Value Register**

Offset:0x28			Register Name: <b>TMR1_CUR_VALUE_REG</b>
Bit	R/W	Default/Hex	Description
31:0	R/W	0x0	<p>TMR1_CUR_VALUE. Timer 1 Current Value.</p> <p>It is a 32-bit down-counter (from interval value to 0).</p>

**4.5.4.9. Timer 2 Control Register**

Offset:0x30			Register Name: <b>TMR2_CTRL_REG</b>
Bit	R/W	Default/Hex	Description
31:8	/	/	/
7	R/W	0x0	<p>TMR2_MODE. Timer 2 mode.</p> <p>0: Continuous mode. When interval value reached, the timer will not disable automatically.</p> <p>1: Single mode. When interval value reached, the timer will disable automatically.</p>
6:4	R/W	0x0	TMR2_CLK_PRES.

			<p>Select the pre-scale of timer 2 clock source.</p> <p>000: /1 001: /2 010: /4 011: /8 100: /16 101: /32 110: /64 111: /128</p>
3:2	R/W	0x1	<p>TMR2_CLK_SRC.</p> <p>00: Internal OSC / 512 01: OSC24M. 10: / 11: /.</p>
1	R/W	0x0	<p>TMR2_RELOAD.</p> <p>Timer 2 Reload.</p> <p>0: No effect, 1: Reload timer 2 Interval value. After the bit is set, it can not be written again before it's cleared automatically.</p>
0	R/W	0x0	<p>TMR2_EN.</p> <p>Timer 2 Enable.</p> <p>0: Stop/Pause, 1: Start.</p> <p>If the timer is started, it will reload the interval value to internal register, and the current counter will count from interval value to 0.</p> <p>If the current counter does not reach the zero, the timer enable bit is set to "0", the current value counter will pause. At least wait for 2 cycles, the start bit can be set to 1.</p> <p>In timer pause state, the interval value register can be modified. If the timer is started again, and the Software hope the current value register to down-count from the new interval value, the reload bit and the enable bit should be set to 1 at the same time.</p>

#### 4.5.4.10. Timer 2 Interval Value Register

Offset:0x34			Register Name: <b>TMR2_INTV_VALUE_REG</b>
Bit	R/W	Default/Hex	Description
31:0	R/W	0x0	<p>TMR2_INTV_VALUE.</p> <p>Timer 2 Interval Value.</p> <p><b>Note:</b>The value setting should consider the system clock and the timer clock source.</p>

**4.5.4.11. Timer 2 Current Value Register**

Offset:0x38			Register Name: <b>TMR2_CUR_VALUE_REG</b>
Bit	R/W	Default/Hex	Description
31:0	R/W	0x0	TMR2_CUR_VALUE. Timer 2 Current Value. <b>Note:</b> Timer 2 current value is a 32-bit down-counter (from interval value to 0).

**4.5.4.12. AVS Counter Control Register (Default Value: 0x00000000)**

Offset:0x80			Register Name: <b>AVS_CNT_CTL_REG</b>
Bit	R/W	Default/Hex	Description
31:10	/	/	/
9	R/W	0x0	AVS_CNT1_PS. Audio/Video Sync Counter 1 Pause Control 0: Not pause 1: Pause Counter 1.
8	R/W	0x0	AVS_CNT0_PS. Audio/Video Sync Counter 0 Pause Control 0: Not pause 1: Pause Counter 0.
7:2	/	/	/
1	R/W	0x0	AVS_CNT1_EN. Audio/Video Sync Counter 1 Enable/ Disable. The counter source is OSC24M. 0: Disable 1: Enable.
0	R/W	0x0	AVS_CNT0_EN. Audio/Video Sync Counter 1 Enable/ Disable. The counter source is OSC24M. 0: Disable 1: Enable.

**4.5.4.13. AVS Counter 0 Register (Default Value: 0x00000000)**

Offset:0x84			Register Name: <b>AVS_CNT0_REG</b>
Bit	R/W	Default/Hex	Description
31:0	R/W	0x0	AVS_CNT0. Counter 0 for Audio/ Video Sync Application The high 32 bits of the internal 33-bits counter register. The initial value of the internal 33-bits counter register can be set by software. The LSB bit of the 33-bits counter register should be zero when the initial value is updated. It will count from the initial value. The initial value can be updated at any time. It can also be paused by setting AVS_CNT0_PS to '1'. When it is paused,

			the counter won't increase.
--	--	--	-----------------------------

#### 4.5.4.14. AVS Counter 1 Register (Default Value: 0x00000000)

Offset:0x88			Register Name: <b>AVS_CNT1_REG</b>
Bit	R/W	Default/Hex	Description
31:0	R/W	0x0	<p>AVS_CNT1.</p> <p>Counter 1 for Audio/ Video Sync Application</p> <p>The high 32 bits of the internal 33-bits counter register. The initial value of the internal 33-bits counter register can be set by software. The LSB bit of the 33-bits counter register should be zero when the initial value is updated. It will count from the initial value. The initial value can be updated at any time. It can also be paused by setting AVS_CNT1_PS to '1'. When it is paused, the counter won't increase.</p>

#### 4.5.4.15. AVS Counter Divisor Register (Default Value: 0x05DB05DB)

Offset:0x8C			Register Name: <b>AVS_CNT_DIV_REG</b>
Bit	R/W	Default/Hex	Description
31:28	/	/	/
27:16	R/W	0x5DB	<p>AVS_CNT1_D.</p> <p>Divisor N for AVS Counter 1</p> <p>AVS CN1 CLK=24MHz/Divisor_N1.</p> <p>Divisor N1 = Bit [27:16] + 1.</p> <p>The number N is from 1 to 0x7ff. The zero value is reserved.</p> <p>The internal 33-bits counter engine will maintain another 12-bits counter. The 12-bits counter is used for counting the cycle number of one 24Mhz clock. When the 12-bits counter reaches (<math>\geq</math> N) the divisor value, the internal 33-bits counter register will increase 1 and the 12-bits counter will reset to zero and restart again.</p> <p><b>Note:</b> It can be configured by software at any time.</p>
15:12	/	/	/
11:0	R/W	0x5DB	<p>AVS_CNT0_D.</p> <p>Divisor N for AVS Counter 0</p> <p>AVS CN0 CLK=24MHz/Divisor_N0.</p> <p>Divisor N0 = Bit [11:0] + 1</p> <p>The number N is from 1 to 0x7ff. The zero value is reserved.</p> <p>The internal 33-bits counter engine will maintain another 12-bits counter. The 12-bits counter is used for counting the cycle number of one 24Mhz clock. When the 12-bits counter reaches (<math>\geq</math> N) the divisor value, the internal 33-bits counter register will increase 1 and the 12-bits counter will reset to zero and restart again.</p>

			<b>Note:</b> It can be configured by software at any time.
--	--	--	--

**4.5.4.16. Watchdog IRQ Enable Register (Default Value: 0x00000000)**

Offset:0xA0			Register Name: <b>WDOG_IRQ_EN_REG</b>
Bit	R/W	Default/Hex	Description
31:1	/	/	/
0	R/W	0x0	WDOG_IRQ_EN. Watchdog Interrupt Enable. 0: No effect 1: Watchdog0 interrupt enable.

**4.5.4.17. Watchdog Status Register (Default Value: 0x00000000)**

Offset:0xA4			Register Name: <b>WDOG_IRQ_STA_REG</b>
Bit	R/W	Default/Hex	Description
31:1	/	/	/
0	R/W	0x0	WDOG_IRQ_PEND. Watchdog IRQ Pending. Set 1 to the bit will clear it. 0: No effect, 1: Pending, watchdog0 interval value is reached.

**4.5.4.18. Watchdog Control Register (Default Value: 0x00000000)**

Offset:0xB0			Register Name: <b>WDOG_CTRL_REG</b>
Bit	R/W	Default/Hex	Description
31:13	/	/	/
12:1	R/W	0x0	WDOG_KEY_FIELD. Watchdog Key Field. Should be written at value 0xA57. Writing any other value in this field aborts the write operation.
0	R/W	0x0	WDOG_RSTART. Watchdog Restart. 0: No effect, 1: Restart watchdog.

**4.5.4.19. Watchdog Configuration Register (Default Value: 0x00000001)**

Offset:0xB4	Register Name: <b>WDOG_CFG_REG</b>
-------------	------------------------------------

Bit	R/W	Default/Hex	Description
31:2	/	/	/
1:0	R/W	0x1	WDOG_CONFIG. Watchdog generates a reset signal 00: / 01: To whole system 10: Only interrupt 11: /

#### 4.5.4.20. Watchdog Mode Register (Default Value: 0x00000000)

Offset:0xB8			Register Name: <b>WDOG_MODE_REG</b>
Bit	R/W	Default/Hex	Description
31:8	/	/	/
7:4	R/W	0x0	WDOG_INTV_VALUE. Watchdog Interval Value Watchdog clock source is <i>OSC24M / 750</i> . If the clock source is turned off, Watchdog will not work. 0000: 16000 cycles (0.5s) 0001: 32000 cycles (1s) 0010: 64000 cycles (2s) 0011: 96000 cycles (3s) 0100: 128000 cycles (4s) 0101: 160000 cycles (5s) 0110: 192000 cycles (6s) 0111: 256000 cycles (8s) 1000: 320000 cycles (10s) 1001: 384000 cycles (12s) 1010: 448000 cycles (14s) 1011: 512000 cycles (16s) others: /
3:1	/	/	/
0	R/W	0x0	WDOG_EN. Watchdog Enable. 0: No effect; 1: Enable watchdog.

#### 4.5.4.21. 64-bit Counter Control Register (Default Value: 0x00000000)

Offset:0xD0			Register Name: <b>CNT64_CTRL_REG</b>
Bit	R/W	Default/Hex	Description
31	R/W	0x0	CNT64_TEST_EN.



			64-bit Counter Test Mode Enable. 0: Normal Mode, 1: Test Mode. In the Test Mode, this Counter Low/Hi registers will count simultaneously.
30:3	/	/	/.
2	R/W	0x0	CNT64_CLK_SRC_SEL. 64-bit Counter Clock Source Select. 0: OSC24M 1: /
1	R/W	0x0	CNT64_RL_EN. 64-bit Counter Read Latch Enable. 0: no effect, 1: to latch the 64-bit Counter to the Low/Hi registers and it will change to zero after the registers are latched.
0	R/W	0x0	CNT64_CLR_EN. 64-bit Counter Clear Enable. 0: no effect, 1: to clear the 64-bit Counter Low/Hi registers and it will change to zero after the registers are cleared. <b>Note:</b> It is not recommended to clear this counter arbitrarily.

#### 4.5.4.22. 64-bit Counter Low Register (Default Value: 0x00000000)

Offset:0xD4			Register Name: <b>CNT64_LOW_REG</b>
Bit	R/W	Default/Hex	Description
31:0	R/W	0x0	CNT64_LO. 64-bit Counter [31:0].

#### 4.5.4.23. 64-bit Counter High Register (Default Value: 0x00000000)

Offset:0xD8			Register Name: <b>CNT64_HIGH_REG</b>
Bit	R/W	Default/Hex	Description
31:0	R/W	0x0	CNT64_HI. 64-bit Counter [63:32].

## 4.6. High-speed Timer

### 4.6.1. Overview

High Speed Timer Clock Source are fixed to AHBCLK, which is much higher than OSC24M. Compared with other timers, High Speed Timer clock source is synchronized with AHB clock, and when the relevant bit in the Control Register is set 1, timer goes into the test mode, which is used to System Simulation. When the current value in both LO and HI Current Value Register are counting down to zero, the timer will generate interrupt if set interrupt enable bit.

The High Speed Timer includes the following features:

- 56-bit counter
- Clock source is synchronized with AHB clock, which means calculating much more accurate than other timers

### 4.6.2. Operation Principle

#### 4.6.2.1. HSTimer clock gating and software reset

By default the HSTimer clock gating is mask. When it is necessary to use HSTimer, it's clock gating should be open in **BUS Clock Gating Register0** and then de-assert the software reset in **BUS Software Reset Register0** on CCU module. If it is no need to use HSTimer, both the gating bit and software reset bit should be set 0.

#### 4.6.2.2. HSTimer reload bit

Differing from the reload of Timer, when interval value is reloaded into current value register, the reload bit would not turn to 0 automatically until you clear it. If software hopes the current value register to down-count from the new interval value in pause status, the reload bit and the enable bit should be written 1 at the same time.

### 4.6.3. HSTimer Register List

Module Name	Base Address
High Speed Timer	0x01C60000

Register Name	Offset	Description
HS_TMR_IRQ_EN_REG	0x00	HS Timer IRQ Enable Register
HS_TMR_IRQ_STAS_REG	0x04	HS Timer Status Register

HS_TMR0_CTRL_REG	0x10	HS Timer0 Control Register
HS_TMR0_INTV_LO_REG	0x14	HS Timer0 Interval Value Low Register
HS_TMR0_INTV_HI_REG	0x18	HS Timer0 Interval Value High Register
HS_TMR0_CURNT_LO_REG	0x1C	HS Timer0 Current Value Low Register
HS_TMR0_CURNT_HI_REG	0x20	HS Timer0 Current Value High Register
HS_TMR1_CTRL_REG	0x30	HS Timer1 Control Register
HS_TMR1_INTV_LO_REG	0x34	HS Timer1 Interval Value Low Register
HS_TMR1_INTV_HI_REG	0x38	HS Timer1 Interval Value High Register
HS_TMR1_CURNT_LO_REG	0x3C	HS Timer1 Current Value Low Register
HS_TMR1_CURNT_HI_REG	0x40	HS Timer1 Current Value High Register

#### 4.6.4. HSTimer Register Description

##### 4.6.4.1. HS Timer IRQ Enable Register (Default Value: 0x00000000)

Offset:0x0			Register Name: <b>HS_TMR_IRQ_EN_REG</b>
Bit	R/W	Default/Hex	Description
31:2	/	/	/
1	R/W	0x0	HS_TMR1_INT_EN. High Speed Timer1 Interrupt Enable. 0: No effect; 1: High Speed Timer1 Interval Value reached interrupt enable.
0	R/W	0x0	HS_TMR0_INT_EN. High Speed Timer0 Interrupt Enable. 0: No effect; 1: High Speed Timer0 Interval Value reached interrupt enable.

##### 4.6.4.2. HS Timer IRQ Status Register (Default Value: 0x00000000)

Offset:0x4			Register Name: <b>HS_TMR_IRQ_STAS_REG</b>
Bit	R/W	Default/Hex	Description
31:2	/	/	/
1	R/W	0x0	HS_TMR1_IRQ_PEND. High Speed Timer1 IRQ Pending. Set 1 to the bit will clear it. 0: No effect; 1: Pending, High speed timer interval value is reached.
0	R/W	0x0	HS_TMR0_IRQ_PEND. High Speed Timer0 IRQ Pending. Set 1 to the bit will clear it. 0: No effect; 1: Pending, High speed timer interval value is reached.

**4.6.4.3. HS Timer0 Control Register (Default Value: 0x00000000)**

Offset:0x10			Register Name: <b>HS_TMRO_CTRL_REG</b>
Bit	R/W	Default/Hex	Description
31	R/W	0x0	HS_TMRO_TEST. High speed timer0 test mode. In test mode, the low register should be set to 0x1, the high register will down counter. The counter needs to be reloaded. 0: normal mode; 1: test mode.
30:8	/	/	/
7	R/W	0x0	HS_TMRO_MODE. High Speed Timer0 mode. 0: Continuous mode. When interval value reached, the timer will not disable automatically. 1: Single mode. When interval value reached, the timer will disable automatically.
6:4	R/W	0x0	HS_TMRO_CLK Select the pre-scale of the high speed timer0 clock sources. 000: /1 001: /2 010: /4 011: /8 100: /16 101: / 110: / 111: /
3:2	/	/	/
1	R/W	0x0	HS_TMRO_RELOAD. High Speed Timer0 Reload. 0: No effect, 1: Reload High Speed Timer0 Interval Value.
0	R/W	0x0	HS_TMRO_EN. High Speed Timer0 Enable. 0: Stop/Pause, 1: Start. If the timer is started, it will reload the interval value to internal register, and the current counter will count from interval value to 0. If the current counter does not reach the zero, the timer enable bit is set to "0", the current value counter will pause. At least wait for 2 cycles, the start bit can be set to 1. In timer pause state, the interval value register can be modified. If the timer is started again, and the Software hope the current value register to down-count from the new interval value, the reload bit and the enable bit should be set to 1 at the same time.

**4.6.4.4. HS Timer0 Interval Value Lo Register**

Offset:0x14			Register Name: <b>HS_TMRO_INTV_LO_REG</b>
Bit	R/W	Default/Hex	Description
31:0	R/W	x	HS_TMRO_INTV_VALUE_LO. High Speed Timer Interval Value [31:0].

**4.6.4.5. HS Timer0 Interval Value Hi Register**

Offset:0x18			Register Name: <b>HS_TMRO_INTV_HI_REG</b>
Bit	R/W	Default/Hex	Description
31:24	/	/	/
23:0	R/W	x	HS_TMRO_INTV_VALUE_HI. High Speed Timer0 Interval Value [55:32].

**Note:**The interval value register is a 56-bit register. When read or write the interval value, the Lo register should be read or write first. And the Hi register should be written after the Lo register.

**4.6.4.6. HS Timer0 Current Value Lo Register**

Offset:0x1C			Register Name: <b>HS_TMRO_CURNT_LO_REG</b>
Bit	R/W	Default/Hex	Description
31:0	R/W	x	HS_TMRO_CUR_VALUE_LO. High Speed Timer0 Current Value [31:0].

**4.6.4.7. HS Timer0 Current Value Hi Register**

Offset:0x20			Register Name: <b>HS_TMRO_CURNT_HI_REG</b>
Bit	R/W	Default/Hex	Description
31:24	/	/	/
23:0	R/W	x	HS_TMRO_CUR_VALUE_HI. High Speed Timer0 Current Value [55:32].

**Note 1:**HSTimer0 current value is a 56-bit down-counter (from interval value to 0).

**Note2:**The current value register is a 56-bit register. When read or write the current value, the Lo register should be read or write first.

**4.6.4.8. HS Timer1 Control Register (Default Value: 0x00000000)**

Offset:0x30			Register Name: <b>HS_TMR1_CTRL_REG</b>
Bit	R/W	Default/Hex	Description

31	R/W	0x0	<p>HS_TMR1_TEST.</p> <p>High speed timer1 test mode. In test mode, the low register should be set to 0x1, the high register will down counter. The counter needs to be reloaded.</p> <p>0: normal mode; 1: test mode.</p>
30:8	/	/	/
7	R/W	0x0	<p>HS_TMR1_MODE.</p> <p>High Speed Timer1 mode.</p> <p>0: Continuous mode. When interval value reached, the timer will not disable automatically.</p> <p>1: Single mode. When interval value reached, the timer will disable automatically.</p>
6:4	R/W	0x0	<p>HS_TMR1_CLK</p> <p>Select the pre-scale of the high speed timer1 clock sources.</p> <p>000: /1 001: /2 010: /4 011: /8 100: /16 101: / 110: / 111: /</p>
3:2	/	/	/
1	R/W	0x0	<p>HS_TMR1_RELOAD.</p> <p>High Speed Timer1 Reload.</p> <p>0: No effect, 1: Reload High Speed Timer1 Interval Value.</p>
0	R/W	0x0	<p>HS_TMR1_EN.</p> <p>High Speed Timer1 Enable.</p> <p>0: Stop/Pause, 1: Start.</p> <p>If the timer is started, it will reload the interval value to internal register, and the current counter will count from interval value to 0.</p> <p>If the current counter does not reach the zero, the timer enable bit is set to "0", the current value counter will pause. At least wait for 2 cycles, the start bit can be set to 1.</p> <p>In timer pause state, the interval value register can be modified. If the timer is started again, and the Software hope the current value register to down-count from the new interval value, the reload bit and the enable bit should be set to 1 at the same time.</p>

#### 4.6.4.9. HS Timer1 Interval Value Lo Register

Offset:0x34			Register Name: <b>HS_TMR1_INTV_LO_REG</b>
Bit	R/W	Default/Hex	Description
31:0	R/W	x	HS_TMR0_INTV_VALUE_LO.

		High Speed Timer Interval Value [31:0].
--	--	---

**4.6.4.10. HS Timer1 Interval Value Hi Register**

Offset:0x38			Register Name: <b>HS_TMR1_INTV_HI_REG</b>
Bit	R/W	Default/Hex	Description
31:24	/	/	/
23:0	R/W	x	HS_TMR1_INTV_VALUE_HI. High Speed Timer1 Interval Value [55:32].

**Note:** The interval value register is a 56-bit register. When read or write the interval value, the Lo register should be read or write first. And the Hi register should be written after the Lo register.

**4.6.4.11. HS Timer1 Current Value Lo Register**

Offset:0x3C			Register Name: <b>HS_TMR1_CURNT_LO_REG</b>
Bit	R/W	Default/Hex	Description
31:0	R/W	x	HS_TMR1_CUR_VALUE_LO. High Speed Timer1 Current Value [31:0].

**4.6.4.12. HS Timer1 Current Value Hi Register**

Offset:0x40			Register Name: <b>HS_TMR1_CURNT_HI_REG</b>
Bit	R/W	Default/Hex	Description
31:24	/	/	/
23:0	R/W	x	HS_TMR1_CUR_VALUE_HI. High Speed Timer1 Current Value [55:32].

**Note1:** HS timer1 current value is a 56-bit down-counter (from interval value to 0).

**Note2:** The current value register is a 56-bit register. When read or write the current value, the Lo register should be read or write first.

**4.6.5. Programming Guidelines**

Take making a 1us delay using HSTimer for an instance as follow, AHB1CLK will be configured as 100MHz and n\_mode, Single mode and 2 pre-scale will be selected in this instance.

```
writel(0x0, HS_TMR_INTV_HI); //Set interval value Hi 0x0
writel(0x32, HS_TMR_INTV_LO); //Set interval value Lo 0x32
```

```
writel(0x90, HS_TMR_CTRL); //Select n_mode,2 pre-scale,single mode
writel(readl(HS_TMR_CTRL)|(1<<1), HS_TMR_CTRL); //Set Reload bit
writel(readl(HS_TMR_CTRL)|(1<<0), HS_TMR_CTRL); //Enable HSTimer
While(!(readl(HS_TMR_IRQ_STAT)&1)); //Wait for HSTimer to generate pending
Writel(1,HS_TMR_IRQ_STAT); //Clear HSTimer pending
```



## 4.7. PWM

### 4.7.1. Overview

The output of the PWM is a toggling signal whose frequency and duty cycle can be modulated by its programmable registers. Each channel has a dedicated internal 16-bit up counter. If the counter reaches the value stored in the channel period register, it resets. At the beginning of a count period cycle, the PWMOUT is set to active state and count from 0x0000. The PWM divider divides the clock (24MHz) by 1~4096 according to the pre-scalar bits in the PWM control register.

In PWM cycle mode, the output will be a square waveform, the frequency is set to the period register. In PWM pulse mode, the output will be a positive pulse or a negative pulse.

### 4.7.2. Functionalities Description

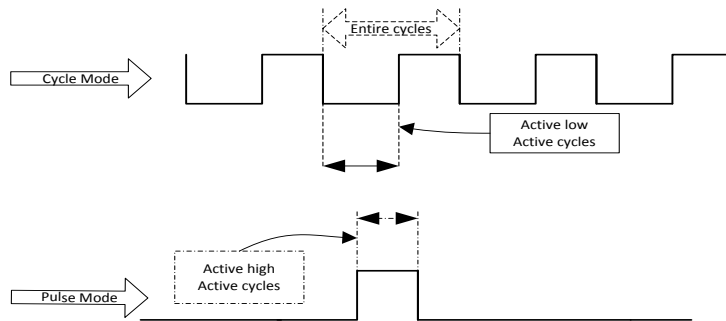

Figure 4-5. PWM Block Diagram

When PWM is enabling, the PWM can output two signals, which are reversed on two pins. And when PWM is disabling, the PWM can control the status of two pins. The PWM divider divides the clock (24MHz) by 1-64 according to the pre-scalar bits in the PWM control register. The PWM output Frequency can be divided by 65536 at most. In PWM cycle mode, the output will be a square waveform; the frequency is set to the period register. In PWM pulse mode, the output will be a positive pulse or a negative pulse.

### 4.7.3. PWM Register List

Module Name	Base Address
PWM	0x01C21400

Register Name	Offset	Description
---------------	--------	-------------

PWM_CH_CTRL	0x00	PWM Control Register
PWM_CH0_PERIOD	0x04	PWM Channel 0 Period Register
PWM_CH1_PERIOD	0x08	PWM Channel 1 Period Register

#### 4.7.4. PWM Register Description

##### 4.7.4.1. PWM Control Register(Default Value: 0x00000000)

Offset:0x0			Register Name: <b>PWM_CTRL_REG</b>
Bit	R/W	Default/Hex	Description
31:30	/	/	/.
29	RO	0x0	PWM1_RDY. PWM1 period register ready. 0: PWM1 period register is ready to write, 1: PWM1 period register is busy.
28	RO	0x0	PWM0_RDY. PWM0 period register ready. 0: PWM0 period register is ready to write, 1: PWM0 period register is busy.
27:25	/	/	/
24	R/W	0x0	PWM1_BYPASS. PWM CH1 bypass enable. If the bit is set to 1, PWM1's output is OSC24MHz. 0: disable 1: enable
23	R/W	0x0	PWM_CH1_PULSE_OUT_START. PWM Channel 1 pulse output start. 0: no effect, 1: output 1 pulse. The pulse width should be according to the period 1 register[15:0],and the pulse state should be according to the active state. After the pulse is finished, the bit will be cleared automatically.
22	R/W	0x0	PWM_CH1_MODE. PWM Channel 1 mode. 0: cycle mode, 1: pulse mode.
21	R/W	0x0	PWM_CH1_CLK_GATING Gating the Special Clock for PWM1(0: mask, 1: pass).
20	R/W	0x0	PWM_CH1_ACT_STATE. PWM Channel 1 Active State. 0: Low Level, 1: High Level.
19	R/W	0x0	PWM_CH1_EN.

			<p>PWM Channel 1 Enable.</p> <p>0: Disable, 1: Enable.</p>
18:15	R/W	0x0	<p>PWM_CH1_PRESCAL.</p> <p>PWM Channel 1 Prescalar.</p> <p>These bits should be setting before the PWM Channel 1 clock gate on.</p> <p>0000: /120 0001: /180 0010: /240 0011: /360 0100: /480 0101: / 0110: / 0111: / 1000: /12k 1001: /24k 1010: /36k 1011: /48k 1100: /72k 1101: / 1110: / 1111: /1</p>
14:10	/	/	/
9	R/W	0x0	<p>PWM0_BYPASS.</p> <p>PWM CH0 bypass enable.</p> <p>If the bit is set to 1, PWM0's output is OSC24MHz.</p> <p>0: disable, 1: enable.</p>
8	R/W	0x0	<p>PWM_CH0_PUL_START.</p> <p>PWM Channel 0 pulse output start.</p> <p>0: no effect, 1: output 1 pulse.</p> <p>The pulse width should be according to the period 0 register[15:0],and the pulse state should be according to the active state.</p> <p>After the pulse is finished,the bit will be cleared automatically.</p>
7	R/W	0x0	<p>PWM_CHANNELO_MODE.</p> <p>0: cycle mode, 1: pulse mode.</p>
6	R/W	0x0	<p>SCLK_CH0_GATING.</p> <p>Gating the Special Clock for PWM0(0: mask, 1: pass).</p>
5	R/W	0x0	<p>PWM_CH0_ACT_STA.</p> <p>PWM Channel 0 Active State.</p> <p>0: Low Level, 1: High Level.</p>
4	R/W	0x0	<p>PWM_CH0_EN.</p>

			PWM Channel 0 Enable. 0: Disable, 1: Enable.
3:0	R/W	0x0	PWM_CH0_PRESCAL. PWM Channel 0 Prescalar. These bits should be setting before the PWM Channel 0 clock gate on. 0000: /120 0001: /180 0010: /240 0011: /360 0100: /480 0101: / 0110: / 0111: / 1000: /12k 1001: /24k 1010: /36k 1011: /48k 1100: /72k 1101: / 1110: / 1111: /1

#### 4.7.4.2. PWM Channel 0 Period Register

Offset:0x4			Register Name: <b>PWM_CH0_PERIOD</b>
Bit	R/W	Default/Hex	Description
31:16	R/W	x	PWM_CH0_ENTIRE_CYS Number of the entire cycles in the PWM clock. 0 = 1 cycle 1 = 2 cycles ..... N = N+1 cycles If the register need to be modified dynamically, the PCLK should be faster than the PWM CLK (PWM CLK = 24MHz/pre-scale).
15:0	R/W	x	PWM_CH0_ENTIRE_ACT_CYS Number of the active cycles in the PWM clock. 0 = 0 cycle 1 = 1 cycles ..... N = N cycles

**Note:**The active cycles should be no larger than the period cycles.

**4.7.4.3. PWM Channel 1 Period Register**

Offset:0x8			Register Name: <b>PWM_CH1_PERIOD</b>
Bit	R/W	Default/Hex	Description
31:16	R/W	x	<b>PWM_CH1_ENTIRE_CYS</b> Number of the entire cycles in the PWM clock. 0 = 1 cycle 1 = 2 cycles ..... N = N+1 cycles If the register need to be modified dynamically, the PCLK should be faster than the PWM CLK (PWM CLK = 24MHz/pre-scale).
15:0	R/W	x	<b>PWM_CH1_ENTIRE_ACT_CYS</b> Number of the active cycles in the PWM clock. 0 = 0 cycle 1 = 1 cycles ..... N = N cycles

**Note:**The active cycles should be no larger than the period cycles.

## 4.8. DMA

### 4.8.1. Overview

There are 8 DMA channels in the chip. Each DMA channel can generate interrupts. According to different pending status, the referenced DMA channel generates corresponding interrupt. And, the configuration information of every DMA channel are storing in the DDR or SRAM. When start a DMA transferring, the **DMA Channel Descriptor Address Register** contains the address information in the DDR or SRAM, where has the relevance configuration information of the DMA transferring.

### 4.8.2. Functionalities Description

#### 4.8.2.1. Block Diagram

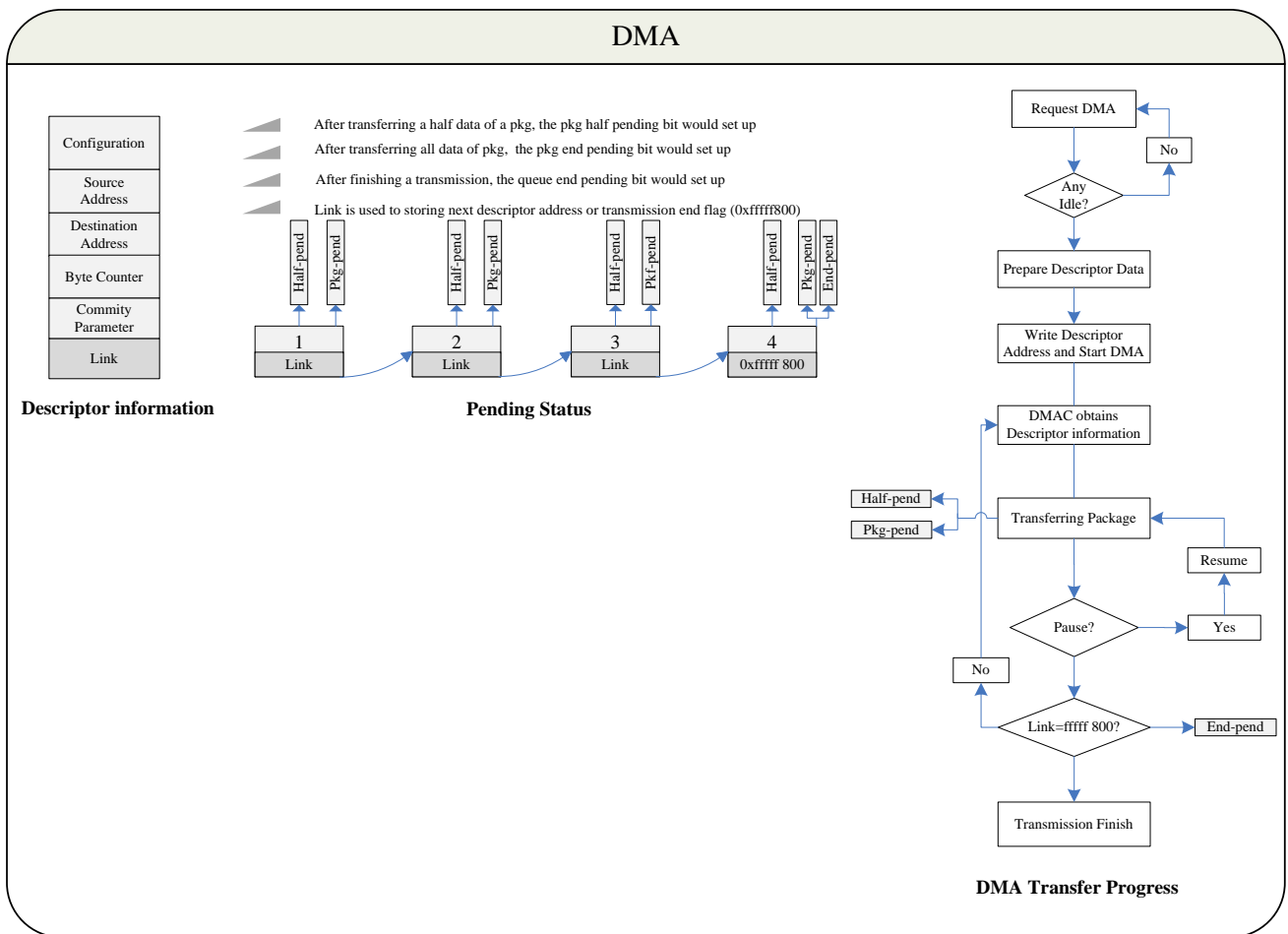

Figure 4-6. DMA Block Diagram

4.8.2.2. DRQ Type and Corresponding Relation

Table 4-1. DMA DRQ Table

Source DRQ Type		Destination DRQ Type	
Port NO.	Module Name	Port NO.	Module Name
Port 0	SRAM	Port 0	SRAM
Port 1	SDRAM	Port 1	SDRAM
Port 2		Port 2	
Port 3		Port 3	
Port 4		Port 4	
Port 5		Port 5	
Port 6	UART0_RX	Port 6	UART0_TX
Port 7	UART1_RX	Port 7	UART1_TX
Port 8	UART2_RX	Port 8	UART2_TX
Port 9	/	Port 9	/
Port 10	/	Port 10	/
Port 11	/	Port 11	/
Port 12	/	Port 12	/
Port 13	/	Port 13	/
Port 14	/	Port 14	/
Port 15	Audio Codec	Port 15	Audio Codec
Port 16	CE_RX	Port 16	CE_TX
Port 17	USB OTG_Device_EP1	Port 17	USB OTG_Device_EP1
Port 18	USB OTG_Device_EP2	Port 18	USB OTG_Device_EP2
Port 19	USB OTG_Device_EP3	Port 19	USB OTG_Device_EP3
Port20	USB OTG_Device_EP4	Port 20	USB OTG_Device_EP4
Port 21	/	Port 21	/
Port 22	/	Port 22	/
Port 23	SPI0_RX	Port 23	SPI0_TX
Port 24		Port 24	
Port 25		Port 25	
Port 26		Port 26	
Port 27		Port 27	
Port 28		Port 28	
Port 29		Port 29	
Port 30		Port 30	

4.8.2.3. DMA Descriptor

In this section, the DMA descriptor registers will be introduced in detail.

When starting a DMA transmission, the module data are transferred as packages, which have the link data information. And, by reading the DMA Status Register, the status of a DMA channel could be known. Reading back the descriptor

address register, the value is the link data in the transferring package. If only the value is equal to 0xffff800, then it can be regarded as NULL, which means the package is the last package in this DMA transmission. Otherwise, the value means the start address of the next package. And, the Descriptor Address Register can be changed during a package transferring.

When transferring the half of a package, the relevant pending bit will be set up automatically, and if the corresponding interrupt is enabled, DMA generates an interrupt to the system. The similar thing would occur when transferring a package completely. Meanwhile, if DMA have transferred the last package in the data, the relevant pending bit would be set up, and generates an interrupt if the corresponding interrupt is enabled. The flow-process diagram is showed in Block Diagram section.

During a DMA transmission, the configuration could be obtained via the Configuration Register. And, behind the address of the config register in DDR or SRAM, there are some registers including other information of a DMA transmission. The structure chart is showed in Block Diagram section. Also, other information of a transferring data can be obtained by reading the Current Source Address Register, Current Destination Address Register and Byte Counter Left Register. The configuration must be word-aligning.

The transferring data would be paused when setting up the relevant Pause Register, if coming up emergency. And the pausing data could be presumable when set 0 to the same bit in Pause Register.

### 4.8.3. DMA Register List

Module Name	Base Address
DMA	0x01C02000

Register Name	Offset	Description
DMA_IRQ_EN_REG	0x00	DMA IRQ Enable Register
DMA_IRQ_PEND_REG	0x10	DMA IRQ Pending Register
DMA_AUTO_GATE_REG	0x20	DMA Auto Gating Register
DMA_STA_REG	0x30	DMA Status Register
DMA_EN_REG	0x100+N*0x40	DMA Channel Enable Register (N=0~7)
DMA_PAU_REG	0x100+N*0x40+0x4	DMA Channel Pause Register(N=0~7)
DMA_DESC_ADDR_REG	0x100+N*0x40+0x8	DMA Channel Start Address Register(N=0~7)
DMA_CFG_REG	0x100+N*0x40+0xC	DMA Channel Configuration Register(N=0~7)
DMA_CUR_SRC_REG	0x100+N*0x40+0x10	DMA Channel Current Source Register(N=0~7)
DMA_CUR_DEST_REG	0x100+N*0x40+0x14	DMA Channel Current Destination Register(N=0~7)
DMA_BCNT_LEFT_REG	0x100+N*0x40+0x18	DMA Channel Byte Counter Left Register(N=0~7)
DMA_PARA_REG	0x100+N*0x40+0x1C	DMA Channel Parameter Register(N=0~7)



#### 4.8.4. DMA Register Description

##### 4.8.4.1. DMA IRQ Enable Register0 (Default Value: 0x00000000)

Offset: 0x0000			Register Name: <b>DMA_IRQ_EN_REG0</b>
Bit	R/W	Default/Hex	Description
31	/	/	/
30	R/W	0x0	DMA7_QUEUE_IRQ_EN DMA 7 Queue End Transfer Interrupt Enable. 0: Disable, 1: Enable.
29	R/W	0x0	DMA7_PKG_IRQ_EN DMA 7 Package End Transfer Interrupt Enable. 0: Disable, 1: Enable.
28	R/W	0x0	DMA7_HLAF_IRQ_EN DMA 7 Half Package Transfer Interrupt Enable. 0: Disable, 1: Enable.
27	/	/	/
26	R/W	0x0	DMA6_QUEUE_IRQ_EN DMA 6 Queue End Transfer Interrupt Enable. 0: Disable, 1: Enable.
25	R/W	0x0	DMA6_PKG_IRQ_EN DMA 6 Package End Transfer Interrupt Enable. 0: Disable, 1: Enable.
24	R/W	0x0	DMA6_HLAF_IRQ_EN DMA 6 Half Package Transfer Interrupt Enable. 0: Disable, 1: Enable.
23	/	/	/
22	R/W	0x0	DMA5_QUEUE_IRQ_EN DMA 5 Queue End Transfer Interrupt Enable. 0: Disable, 1: Enable.
21	R/W	0x0	DMA5_PKG_IRQ_EN DMA 5 Package End Transfer Interrupt Enable. 0: Disable, 1: Enable.
20	R/W	0x0	DMA5_HLAF_IRQ_EN DMA 5 Half package Transfer Interrupt Enable. 0: Disable, 1: Enable.
19	/	/	/
18	R/W	0x0	DMA4_QUEUE_IRQ_EN DMA 4 Queue End Transfer Interrupt Enable. 0: Disable, 1: Enable.
17	R/W	0x0	DMA4_PKG_IRQ_EN DMA 4 Package End Transfer Interrupt Enable. 0: Disable, 1: Enable.
16	R/W	0x0	DMA4_HLAF_IRQ_EN

			DMA 4 Half Package Transfer Interrupt Enable. 0: Disable, 1: Enable.
15	/	/	/
14	R/W	0x0	DMA3_QUEUE_IRQ_EN DMA 3 Queue End Transfer Interrupt Enable. 0: Disable, 1: Enable.
13	R/W	0x0	DMA3_PKG_IRQ_EN DMA 3 Package End Transfer Interrupt Enable. 0: Disable, 1: Enable.
12	R/W	0x0	DMA3_HLAF_IRQ_EN DMA 3 Half Package Transfer Interrupt Enable. 0: Disable, 1: Enable.
11	/	/	/
10	R/W	0x0	DMA2_QUEUE_IRQ_EN DMA 2 Queue End Transfer Interrupt Enable. 0: Disable, 1: Enable.
9	R/W	0x0	DMA2_PKG_IRQ_EN DMA 2 Package End Transfer Interrupt Enable. 0: Disable, 1: Enable.
8	R/W	0x0	DMA2_HLAF_IRQ_EN DMA 2 Half Package Transfer Interrupt Enable. 0: Disable, 1: Enable.
7	/	/	/
6	R/W	0x0	DMA1_QUEUE_IRQ_EN DMA 1 Queue End Transfer Interrupt Enable. 0: Disable, 1: Enable.
5	R/W	0x0	DMA1_PKG_IRQ_EN DMA 1 Package End Transfer Interrupt Enable. 0: Disable, 1: Enable.
4	R/W	0x0	DMA1_HLAF_IRQ_EN DMA 1 Half Package Transfer Interrupt Enable. 0: Disable, 1: Enable.
3	/	/	/
2	R/W	0x0	DMA0_QUEUE_IRQ_EN DMA 0 Queue End Transfer Interrupt Enable. 0: Disable, 1: Enable.
1	R/W	0x0	DMA0_PKG_IRQ_EN DMA 0 Package End Transfer Interrupt Enable. 0: Disable, 1: Enable.
0	R/W	0x0	DMA0_HLAF_IRQ_EN DMA 0 Half Package Transfer Interrupt Enable. 0: Disable, 1: Enable

**4.8.4.2. DMA IRQ Pending Status Register (Default Value: 0x00000000)**

Offset:0x10			Register Name: <b>DMA_IRQ_PEND_REG</b>
Bit	R/W	Default/Hex	Description
31	/	/	/
30	R/W	0x0	DMA7_QUEUE_IRQ_PEND. DMA 7 Queue End Transfer Interrupt Pending. Set 1 to the bit will clear it. 0: No effect, 1: Pending.
29	R/W	0x0	DMA7_PKG_IRQ_PEND DMA 7 Package End Transfer Interrupt Pending. Set 1 to the bit will clear it. 0: No effect, 1: Pending.
28	R/W	0x0	DMA7_HLAF_IRQ_PEND. DMA 7 Half Package Transfer Interrupt Pending. Set 1 to the bit will clear it. 0: No effect, 1: Pending.
27	/	/	/
26	R/W	0x0	DMA6_QUEUE_IRQ_PEND. DMA 6 Queue End Transfer Interrupt Pending. Set 1 to the bit will clear it. 0: No effect, 1: Pending.
25	R/W	0x0	DMA6_PKG_IRQ_PEND DMA 6 Package End Transfer Interrupt Pending. Set 1 to the bit will clear it. 0: No effect, 1: Pending.
24	R/W	0x0	DMA6_HLAF_IRQ_PEND. DMA 6 Half Package Transfer Interrupt Pending. Set 1 to the bit will clear it. 0: No effect, 1: Pending.
23	/	/	/
22	R/W	0x0	DMA5_QUEUE_IRQ_PEND. DMA 5 Queue End Transfer Interrupt Pending. Set 1 to the bit will clear it. 0: No effect, 1: Pending.
21	R/W	0x0	DMA5_PKG_IRQ_PEND DMA 5 Package End Transfer Interrupt Pending. Set 1 to the bit will clear it. 0: No effect, 1: Pending.
20	R/W	0x0	DMA5_HLAF_IRQ_PEND. DMA 5 Half Package Transfer Interrupt Pending. Set 1 to the bit will clear it. 0: No effect, 1: Pending.
19	/	/	/
18	R/W	0x0	DMA4_QUEUE_IRQ_PEND. DMA 4 Queue End Transfer Interrupt Pending. Set 1 to the bit will clear it. 0: No effect, 1: Pending.
17	R/W	0x0	DMA4_PKG_IRQ_PEND DMA 4 Package End Transfer Interrupt Pending. Set 1 to the bit will clear it. 0: No effect, 1: Pending.
16	R/W	0x0	DMA4_HLAF_IRQ_PEND. DMA 4 Half Package Transfer Interrupt Pending. Set 1 to the bit will clear it. 0: No effect, 1: Pending.

15	/	/	/
14	R/W	0x0	DMA3_QUEUE_IRQ_PEND. DMA 3 Queue End Transfer Interrupt Pending. Set 1 to the bit will clear it. 0: No effect, 1: Pending.
13	R/W	0x0	DMA3_PKG_IRQ_PEND DMA 3 Package End Transfer Interrupt Pending. Set 1 to the bit will clear it. 0: No effect, 1: Pending.
12	R/W	0x0	DMA3_HLAF_IRQ_PEND. DMA 3 Half Package Transfer Interrupt Pending. Set 1 to the bit will clear it. 0: No effect, 1: Pending.
11	/	/	/
10	R/W	0x0	DMA2_QUEUE_IRQ_PEND. DMA 2 Queue End Transfer Interrupt Pending. Set 1 to the bit will clear it. 0: No effect, 1: Pending.
9	R/W	0x0	DMA2_PKG_IRQ_PEND DMA 2 Package End Transfer Interrupt Pending. Set 1 to the bit will clear it. 0: No effect, 1: Pending.
8	R/W	0x0	DMA2_HLAF_IRQ_PEND. DMA 2 Half Package Transfer Interrupt Pending. Set 1 to the bit will clear it. 0: No effect, 1: Pending.
7	/	/	/
6	R/W	0x0	DMA1_QUEUE_IRQ_PEND. DMA 1 Queue End Transfer Interrupt Pending. Set 1 to the bit will clear it. 0: No effect, 1: Pending.
5	R/W	0x0	DMA1_PKG_IRQ_PEND DMA 1 Package End Transfer Interrupt Pending. Set 1 to the bit will clear it. 0: No effect, 1: Pending.
4	R/W	0x0	DMA1_HLAF_IRQ_PEND. DMA 1 Half Package Transfer Interrupt Pending. Set 1 to the bit will clear it. 0: No effect, 1: Pending.
3	/	/	/
2	R/W	0x0	DMA0_QUEUE_IRQ_PEND. DMA 0 Queue End Transfer Interrupt Pending. Set 1 to the bit will clear it. 0: No effect, 1: Pending.
1	R/W	0x0	DMA0_PKG_IRQ_PEND DMA 0 Package End Transfer Interrupt Pending. Set 1 to the bit will clear it. 0: No effect, 1: Pending.
0	R/W	0x0	DMA0_HLAF_IRQ_PEND. DMA 0 Half Package Transfer Interrupt Pending. Set 1 to the bit will clear it. 0: No effect, 1: Pending.

#### 4.8.4.3. DMA Auto Gating Register (Default Value: 0x00000000)

Offset:0x20	Register Name: <b>DMA_AUTO_GATE_REG</b>
-------------	---

Bit	R/W	Default/Hex	Description
31:3	/	/	/
2	R/W	0x0	DMA_MCLK_CIRCUIT. DMA MCLK interface circuit auto gating bit. 0: Auto gating enable 1: Auto gating disable.
1	R/W	0x0	DMA_COMMON_CIRCUIT. DMA common circuit auto gating bit. 0: Auto gating enable 1: Auto gating disable.
0	R/W	0x0	DMA_CHAN_CIRCUIT. DMA channel circuit auto gating bit. 0: Auto gating enable 1: Auto gating disable.

**Note:** When initializing DMA Controller, bit-2 should be set up.

#### 4.8.4.4. DMA Status Register (Default Value: 0x00000000)

Offset:0x30			Register Name: <b>DMA_STA_REG</b>
Bit	R/W	Default/Hex	Description
31:8	/	/	/
7	RO	0x0	DMA7_STATUS DMA Channel 7 Status. 0: Idle 1: Busy
6	RO	0x0	DMA6_STATUS DMA Channel 6 Status. 0: Idle 1: Busy
5	RO	0x0	DMA5_STATUS DMA Channel 5 Status. 0: Idle 1: Busy
4	RO	0x0	DMA4_STATUS DMA Channel 4 Status. 0: Idle 1: Busy.
3	RO	0x0	DMA3_STATUS DMA Channel 3 Status. 0: Idle 1: Busy.
2	RO	0x0	DMA2_STATUS DMA Channel 2 Status. 0: Idle,

			1: Busy.
1	RO	0x0	DMA1_STATUS DMA Channel 1 Status. 0: Idle, 1: Busy.
0	RO	0x0	DMA0_STATUS DMA Channel 0 Status. 0: Idle, 1: Busy.

#### 4.8.4.5. DMA Channel Enable Register (Default Value: 0x00000000)

Offset: 0x100+N*0x40+0x0(N=0~7)			Register Name: <b>DMA_EN_REG</b>
Bit	R/W	Default/Hex	Description
31:1	/	/	/
0	R/W	0x0	DMA_EN. DMA Channel Enable 0: Disable 1: Enable.

**Note:**It's not recommended to disable dma while dma is transmitting.If it is necessary to do that,dma has to be paused first and then disabled.

#### 4.8.4.6. DMA Channel Pause Register (Default Value: 0x00000000)

Offset: 0x100+N*0x40+0x4(N=0~7)			Register Name: <b>DMA_PAU_REG</b>
Bit	R/W	Default/Hex	Description
31:1	/	/	/
0	R/W	0x0	DMA_PAUSE. Pausing DMA Channel Transfer Data. 0: Resume Transferring, 1: Pause Transferring.

#### 4.8.4.7. DMA Channel Descriptor Address Register(Default Value: 0x00000000)

Offset: 0x100+N*0x40+0x8(N=0~7)			Register Name: <b>DMA_DESC_ADDR_REG</b>
Bit	R/W	Default/Hex	Description
31:0	R/W	0x0	DMA_DESC_ADDR DMA Channel Descriptor Address.

**4.8.4.8. DMA Channel Configuration Register (Default Value: 0x00000000)**

Offset: 0x100+N*0x40+0xC(N=0~7)			Register Name: DMA_CFG_REG
Bit	R/W	Default/Hex	Description
31:27	/	/	/
26:25	RO	0x0	DMA_DEST_DATA_WIDTH. DMA Destination Data Width. 00: 8-bit 01: 16-bit 10: 32-bit 11: /
24:23	RO	0x0	DMA_DEST_BST_LEN. DMA Destination Burst Length. 00: 1 01: / 10: 8 11: /
22:21	RO	0x0	DMA_ADDR_MODE. DMA Destination Address Mode 0x0: Linear Mode 0x1: IO Mode 0x2: / 0x3: /
20:16	RO	0x0	DMA_DEST_DRQ_TYPE. DMA Destination DRQ Type The details in DRQ Type and Port Corresponding Relation.
15:11	/	/	/
10:9	RO	0x0	DMA_SRC_DATA_WIDTH. DMA Source Data Width. 00: 8-bit 01: 16-bit 10: 32-bit 11: /
8:7	RO	0x0	DMA_SRC_BST_LEN. DMA Source Burst Length. 00: 1 01: / 10: 8 11: /
6:5	RO	0x0	DMA_SRC_ADDR_MODE. DMA Source Address Mode 0x0: Linear Mode 0x1: IO Mode 0x2: / 0x3: /

4:0	RO	0x0	DMA_SRC_DRQ_TYPE. DMA Source DRQ Type The details in DRQ Type and Port Corresponding Relation.
-----	----	-----	--

**Note1:** If the DRQ type is dram, then, the corresponding burst length will be fixed, and the options will be invalid.

**Note2:** The address of the DMA Channel Configuration Register must be word-aligned.

**Note3:** If the DRQ type is SRAM, then, the source address or destination address must be word-aligned.

#### 4.8.4.9. DMA Channel Current Source Address Register (Default Value: 0x00000000)

Offset: 0x100+N*0x40+0x10(N=0~7)			Register Name: <b>DMA_CUR_SRC_REG</b>
Bit	R/W	Default/Hex	Description
31:0	RO	0x0	DMA_CUR_SRC. DMA Channel Current Source Address, read only.

**Note:** The address of the **DMA Channel Current Source Address Register** must be word-aligned.

#### 4.8.4.10. DMA Channel Current Destination Address Register (Default Value: 0x00000000)

Offset: 0x100+N*0x40+0x14(N=0~7)			Register Name: <b>DMA_CUR_DEST_REG</b>
Bit	R/W	Default/Hex	Description
31:0	RO	0	DMA_CUR_DEST. DMA Channel Current Destination Address, read only.

**Note:** The address of the **DMA Channel Current Destination Address Register** must be word-aligned.

#### 4.8.4.11. DMA Channel Byte Counter Left Register (Default Value: 0x00000000)

Offset: 0x100+N*0x40+0x18(N=0~11)			Register Name: <b>DMA_BCNT_LEFT_REG</b>
Bit	R/W	Default/Hex	Description
31:25	/	/	/
24:0	RO	0x0	DMA_BCNT_LEFT. DMA Channel Byte Counter Left, read only.

**Note:** The address of the **DMA Channel Byte Counter Left Register** must be word-aligned.

#### 4.8.4.12. DMA Channel Parameter Register (Default Value: 0x00000000)

Offset: 0x100+N*0x40+0x1C(N=0~7)			Register Name: <b>DMA_PARA_REG</b>
Bit	R/W	Default/Hex	Description
31:16	/	/	/



15:8	RO	0x0	DATA_BLK_SIZE. Data Block Size N.
7:0	RO	0x0	WAIT_CYC. Wait Clock Cycles n.

**Note1:** The number of data block size usually depends on the capacity of the device's FIFO in the practical application.

**Note2:** The data block size must be multiple of **burst\*width** (byte). For example: if burst is 4 and the width is 32-bit, so the data block size must be **m\*16**(byte), i.e. **N = m \* 16**.

**Note3:** When DMA controller has completed transferring **N** bytes data, and waiting **n** clock cycles to check the DRQ signal.

**Note4:** This register is only effective to devices, and the Data Block Size **N** should be **0** if it is less than **32**.

## 4.9. GIC

For details about GIC, please refer to the *GIC PL400 technical reference manual* and *ARM GIC Architecture Specification V2.0*.

### 4.9.1. Interrupt Source

Interrupt number	Vector	Interrupt Source	Description
0	0x0000	SGI 0	SGI 0 interrupt
1	0x0004	SGI 1	SGI 1 interrupt
2	0x0008	SGI 2	SGI 2 interrupt
3	0x000C	SGI 3	SGI 3 interrupt
4	0x0010	SGI 4	SGI 4 interrupt
5	0x0014	SGI 5	SGI 5 interrupt
6	0x0018	SGI 6	SGI 6 interrupt
7	0x001C	SGI 7	SGI 7 interrupt
8	0x0020	SGI 8	SGI 8 interrupt
9	0x0024	SGI 9	SGI 9 interrupt
10	0x0028	SGI 10	SGI 10 interrupt
11	0x002C	SGI 11	SGI 11 interrupt
12	0x0030	SGI 12	SGI 12 interrupt
13	0x0034	SGI 13	SGI 13 interrupt
14	0x0038	SGI 14	SGI 14 interrupt
15	0x003C	SGI 15	SGI 15 interrupt
16	0x0040	PPI 0	PPI 0 interrupt
17	0x0044	PPI 1	PPI 1 interrupt
18	0x0048	PPI 2	PPI 2 interrupt
19	0x004C	PPI 3	PPI 3 interrupt
20	0x0050	PPI 4	PPI 4 interrupt
21	0x0054	PPI 5	PPI 5 interrupt
22	0x0058	PPI 6	PPI 6 interrupt
23	0x005C	PPI 7	PPI 7 interrupt
24	0x0060	PPI 8	PPI 8 interrupt
25	0x0064	PPI 9	PPI 9 interrupt
26	0x0068	PPI 10	PPI 10 interrupt
27	0x006C	PPI 11	PPI 11 interrupt
28	0x0070	PPI 12	PPI 12 interrupt
29	0x0074	PPI 13	PPI 13 interrupt
30	0x0078	PPI 14	PPI 14 interrupt
31	0x007C	PPI 15	PPI 15 interrupt
32	0x0080	UART 0	UART 0 interrupt
33	0x0084	UART 1	UART 1 interrupt

34	0x0088	UART 2	UART 2 interrupt
35	0x008C		
36	0x0090		
37	0x0094		
38	0x0098	TWI 0	TWI 0 interrupt
39	0x009C	TWI 1	TWI 1 interrupt
40	0x00A0		
41	0x00A4		
42	0x00A8		
43	0x00AC		
44	0x00B0		
45	0x00B4		
46	0x00B8		
47	0x00BC	PB_EINT	PB_EINT interrupt
48	0x00C0		
49	0x00C4	PG_EINT	PG_EINT interrupt
50	0x00C8	Timer 0	Timer 0 interrupt
51	0x00CC	Timer 1	Timer 1 interrupt
52	0x00D0	Timer 2	Timer 2 interrupt
53	0x00D4		
54	0x00D8		
55	0x00DC		
56	0x00E0		
57	0x00E4	Watchdog	Watchdog interrupt
58	0x00E8		
59	0x00EC		
60	0x00F0		
61	0x00F4	Audio Codec	Audio Codec interrupt
62	0x00F8	LRADC	LRADC interrupt
63	0x00FC		
64	0x100	External NMI	External Non-Mask Interrupt
65	0x104		
66	0x108		
67	0x010C		
68	0x0110		
69	0x0114		
70	0x0118		
71	0x011C		
72	0x0120	Alarm 0	Alarm 0 interrupt
73	0x0124	Alarm 1	Alarm 1 interrupt
74	0x0128		
75	0x012C		
76	0x0130		
77	0x0134		

78	0x0138		
79	0x013C		
80	0x0140		
81	0x0144		
82	0x0148	DMA	DMA channel interrupt
83	0x014C	HS Timer0	HS Timer0 interrupt
84	0x0150	HS Timer1	HS Timer1 interrupt
85	0x0154		
86	0x0158		
87	0x015C		
88	0x0160		
89	0x0164		
90	0x0168	VE	VE interrupt
91	0x016C		
92	0x0170	SD/MMC 0	SD/MMC Host Controller 0 interrupt
93	0x0174	SD/MMC 1	SD/MMC Host Controller 1 interrupt
94	0x0178	SD/MMC 2	SD/MMC Host Controller 2 interrupt
95	0x017C		
96	0x0180		
97	0x0184	SPIO	SPIO interrupt
98	0x0188		
99	0x018C		
100	0x0190		
101	0x0194		
102	0x0198		
103	0x019C	USB OTG_Device	USB OTG_Device interrupt
104	0x01A0	USB OTG_EHCI	USB OTG_EHCI interrupt
105	0x01A4	USB OTG_OHCI	USB OTG_OHCI interrupt
106	0x01A8		
107	0x01AC		
108	0x01B0		
109	0x01B4		
110	0x01B8		
111	0x01BC		
112	0x01C0	CE	CE interrupt
113	0x01C4		
114	0x01C8	EMAC	EMAC interrupt
115	0x01CC	CSI0	CSI0 interrupt
116	0x01D0	CSI1	CSI1 interrupt
117	0x01D4	CSI_CCI	CSI_CCI interrupt
118	0x01D8	TCON	TCON Controller interrupt
119	0x01DC		
120	0x01E0		
121	0x01E4		

122	0x01E8	MIPI CSI	MIPI CSI interrupt
123	0x01EC		
124	0x01F0		
125	0x01F4		
126	0x01F8		
127	0x01FC	DE	DE interrupt
128	0x0200		
129	0x0204		
130	0x0208		
131	0x020C		
132	0x0210		
133	0x0214		
134	0x0218		
135	0x021C		
136	0x0220		
137	0x0224		
138	0x0228		
139	0x022C		
140	0x0230	CTI0	CTI0 interrupt
141	0x0234	CTI1	CTI1 interrupt
142	0x0238	CTI2	CTI2 interrupt
143	0x023C	CTI3	CTI3 interrupt
144	0x0240	COMMTX0	COMMTX0 interrupt
145	0x0244	COMMTX1	COMMTX1 interrupt
146	0x0248	COMMTX2	COMMTX2 interrupt
147	0x024C	COMMTX3	COMMTX3 interrupt
148	0x0250	COMMRX0	COMMRX0 interrupt
159	0x0254	COMMRX1	COMMRX1 interrupt
150	0x0258	COMMRX2	COMMRX2 interrupt
151	0x025C	COMMRX3	COMMRX3 interrupt
152	0x0260	PMU0	PMU0 interrupt
153	0x0264	PMU1	PMU1 interrupt
154	0x0268	PMU2	PMU2 interrupt
155	0x026C	PMU3	PMU3 interrupt
156	0x0270	AXI_ERROR	AXI_ERROR interrupt

## 4.10. Crypto Engine

### 4.10.1. Overview

The Crypto Engine (CE) is one encrypt/ decrypt function accelerator. It is suitable for a variety of applications. It can support encryption/decryption and calculate the hash value. Besides, both CPU mode and DMA method are supported for different applications.

It includes the following features:

- Support AES, DES, 3DES, SHA-1, MD5
- 160-bits hardware PRNG with 175-bits seed
- Support ECB, CBC ,CTR,CTS modes for AES/DES/3DES
- 128-bits, 192-bits and 256-bits key size for AES
- Support 32-words RX FIFO and 32-words TX FIFO for high speed application
- Support CPU mode and DMA mode

### 4.10.2. Block Diagram

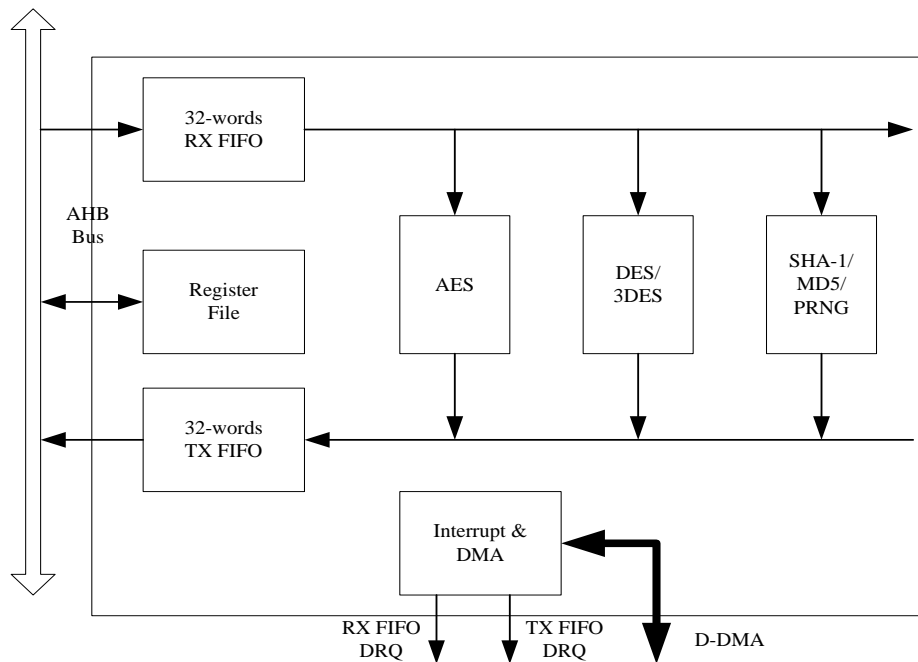

Figure 4-7. CE Block Diagram

### 4.10.3. Crypto Engine Register List

Module Name	Base Address
CE	0x01C15000

Register Name	Offset	Description
CE_CTL	0x00	Control Register
CE_KEY0	0x04	Input Key 0/ PRNG Seed 0
CE_KEY1	0x08	Input Key 1/ PRNG Seed 1
...	...	...
CE_KEY7	0x20	Input Key 7
CE_IV0	0x24	Initialization Vector 0
CE_IV1	0x28	Initialization Vector 1
CE_IV2	0x2C	Initialization Vector 2
CE_IV3	0x30	Initialization Vector 3
CE_CNT0	0x34	Preload Counter 0
CE_CNT1	0x38	Preload Counter 1
CE_CNT2	0x3C	Preload Counter 2
CE_CNT3	0x40	Preload Counter 3
CE_FCSR	0x44	FIFO Control/ Status Register
CE_ICSR	0x48	Interrupt Control/ Status Register
CE_MD0	0x4C	SHA1/MD5 Message Digest 0/PRNG Data0
CE_MD1	0x50	SHA1/MD5 Message Digest 1/PRNG Data1
CE_MD2	0x54	SHA1/MD5 Message Digest 2/PRNG Data2
CE_MD3	0x58	SHA1/MD5 Message Digest 3/PRNG Data3
CE_MD4	0x5C	SHA1/MD5 Message Digest 4/PRNG Data4
CE_CTS_LEN	0x60	AES-CTS ciphertext length
CE_RXFIFO	0x200	RX FIFO input port
CE_TXFIFO	0x204	TX FIFO output port

#### 4.10.4. Crypto Engine Register Description

##### 4.10.4.1. Control Register(Default Value: 0x00000000)

Offset: 0x00			Register Name: CE_CTL
Bit	R/W	Default/Hex	Description
31:28	/	/	/
27:24	R/W	0	SKEY_SELECT AES/DES/3DES key select 0: Select input CE_KEYx (Normal Mode) 1: / 2: /

			3-10: Select internal Key n (n from 0 to 7) Others: Reserved
18:16	R	x	DIE_ID Die Bonding ID
15	R/W	0	PRNG_MODE PRNG generator mode 0: One-shot mode 1: Continue mode
14	R/W	0	IV_MODE IV Steady of SHA-1/MD5 constants 0: Constants 1: Arbitrary IV Notes: It is only used for SHA-1/MD5 engine. If the number of IV word is beyond of 4, Counter 0 register is used for IV4.
13:12	R/W	0	CE_OP_MODE CE Operation Mode 00: Electronic Code Book (ECB) mode 01: Cipher Block Chaining (CBC) mode 10:/ 11: AES Ciphertext Stealing (CTS) mode
11:10	/	/	/
9:8	R/W	0	AES_KEY_SIZE Key Size for AES 00: 128-bits 01: 192-bits 10: 256-bits 11: Reserved
7	R/W	0	CE_OP_DIR CE Operation Direction 0: Encryption 1: Decryption
6:4	R/W	0	CE_METHOD CE Method 000: AES 001: DES 010: Triple DES (3DES) 011: SHA-1 100: MD5 101: PRNG Others: Reserved
3	/	/	/
2	R/W	0	SHA1_MD5_END_BIT SHA-1/MD5 Data End bit Write '1' to tell SHA-1/MD5 engine that the text data is end. If there is some data in FIFO, the engine would fetch these data and process them. After



			finishing message digest, this bit is clear to '0' by hardware and message digest can be read out from digest registers. Notes: It is only used for SHA-1/MD5 engine.
1	R/W	0	PRNG_START PRNG start bit In PRNG one-shot mode, write '1' to start PRNG. After generating one group random data (5 words), this bit is clear to '0' by hardware.
0	R/W	0	CE_ENABLE CE Enable A disable on this bit overrides any other block and flushes all FIFOs. 0: Disable 1: Enable

#### 4.10.4.2. Key [n] Register (Default Value: 0x00000000)

Offset: 0x04+4*n			Register Name: <b>CE_KEY[n]</b>
Bit	R/W	Default/Hex	Description
31:0	R/W	0	CE_KEY Key[n] Input Value (n= 0~7)/ PRNG Seed[n] (n= 0~5)

#### 4.10.4.3. IV[n] Register(Default Value: 0x00000000)

Offset: 0x24+4*n			Register Name: <b>CE_IV[n]</b>
Bit	R/W	Default/Hex	Description
31:0	R/W	0	CE_IV_VALUE Initialization Vector (IV[n]) Input Value (n= 0~3)

#### 4.10.4.4. Count [n] Register (Default Value: 0x00000000)

Offset: 0x34+4*n			Register Name: <b>CE_CNT[n]</b>
Bit	R/W	Default/Hex	Description
31:0	R/W	0	CE_CNT_VALUE Counter Input Value (n= 0~3)

#### 4.10.4.5. FIFO Control/ Status Register (Default Value: 0x60000F0F)

Offset: 0x44			Register Name: <b>CE_FCSR</b>
Bit	R/W	Default/Hex	Description
31	/	/	/

30	R	0x1	RXFIFO_STATUS RX FIFO Empty 0: No room for new word in RX FIFO 1: More than one room for new word in RX FIFO (>= 1 word)
29:24	R	0x20	RXFIFO_EMP_CNT RX FIFO Empty Space Word Counter
23	/	/	/
22	R	0	TXFIFO_STATUS TX FIFO Data Available Flag 0: No available data in TX FIFO 1: More than one data in TX FIFO (>= 1 word)
21:16	R	0	TXFIFO_AVA_CNT TX FIFO Available Word Counter
15:13	/	/	/
12:8	R/W	0xF	RXFIFO_INT_TRIG_LEVEL RX FIFO Empty Trigger Level Interrupt and DMA request trigger level for RXFIFO normal condition Trigger Level = RXTL + 1 Notes: RX FIFO is used for input the data.
7:5	/	/	/
4:0	R/W	0xF	TXFIFO_INT_TRIG_LEVEL TX FIFO Trigger Level Interrupt and DMA request trigger level for TXFIFO normal condition Trigger Level = TXTL + 1 Notes: TX FIFO is used for output the result data.

#### 4.10.4.6. Interrupt Control/ Status Register (Default Value: 0x00000000)

Offset: 0x48			Register Name: <b>CE_ICSR</b>
Bit	R/W	Default/Hex	Description
31:11	/	/	/
10	R/W	0	RXFIFO_EMP_PENDING_BIT RX FIFO Empty Pending bit 0: No pending 1: RX FIFO Empty pending Notes: Write '1' to clear or automatic clear if interrupt condition fails.
9	/	/	/
8	R/W	0	TXFIFO_AVA_PENDING_BIT TX FIFO Data Available Pending bit 0: No TX FIFO pending 1: TX FIFO pending Notes: Write '1' to clear or automatic clear if interrupt condition fails.
7:5	/	/	/

4	R/W	0	DRA_ENABLE DRQ Enable 0: Disable DRQ (CPU polling mode) 1: Enable DRQ (DMA mode)
3	/	/	/
2	R/W	0	RXFIFO_EMP_INT_ENABLE RX FIFO Empty Interrupt Enable 0: Disable 1: Enable Notes: If it is set to '1', when the number of empty room is great or equal (>=) the preset threshold, the interrupt is trigger and the correspond flag is set.
1	/	/	/
0	R/W	0	TXFIFO_AVA_INT_ENABLE TX FIFO Data Available Interrupt Enable 0: Disable 1: Enable Notes: If it is set to '1', when available data number is great or equal (>=) the preset threshold, the interrupt is trigger and the correspond flag is set.

#### 4.10.4.7. Message Digest[n] Register (Default Value: 0x00000000)

Offset: 0x4C+4*n			Register Name: <b>CE_MD[n]</b>
Bit	R/W	Default/Hex	Description
31:0	R	0	CE_MID_DATA SHA1/ MD5 Message digest MD[n] for SHA1/MD5 (n= 0~4)

#### 4.10.4.8. CTS Length Register (Default Value: 0x00000000)

Offset: 0x60			Register Name: <b>CE_CTS_LEN</b>
Bit	R/W	Default/Hex	Description
31:0	R/W	0	AES-CTS ciphertext length in byte unit The value of '0' means no data.

#### 4.10.4.9. RXFIFO Register (Default Value: 0x00000000)

Offset: 0x200			Register Name: <b>CE_RX</b>
Bit	R/W	Default/Hex	Description
31:0	W	0	CE_RX_FIFO 32-bits RX FIFO for Input

**4.10.4.10. TXFIFO Register (Default Value: 0x00000000)**

Offset: 0x204			Register Name: <b>CE_TX</b>
Bit	R/W	Default/Hex	Description
31:0	W	0	CE_RX_FIFO 32-bits TX FIFO for Output

**4.10.5. Crypto Engine Clock Requirement**

Clock Name	Description	Requirement
ahb_clk	AHB bus clock	>=24MHz
CE_clk	Crypto Engine serial clock	<= 150MHz

## 4.11. LRADC

### 4.11.1. Overview

LRADC is 6-bit resolution ADC for key application. The LRADC can work up to 250Hz conversion rate.

The LRADC includes the following features:

- Supports APB 32-bits bus width
- Support interrupt
- Support Hold Key and General Key
- Support Single Key and Continue Key mode
- 6-bits resolution
- Voltage input range between 0V to 2.0V
- Sample rate up to 250Hz

### 4.11.2. Clock Source

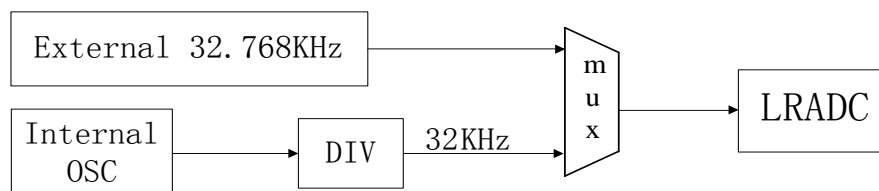

Figure 4-8. LRADC Clock Source

### 4.11.3. Operation Principle

The LRADC converted data can accessed by interrupt and polling method. If software can't access the last converted data instantly, the new converted data would update the old one at new sampling data.

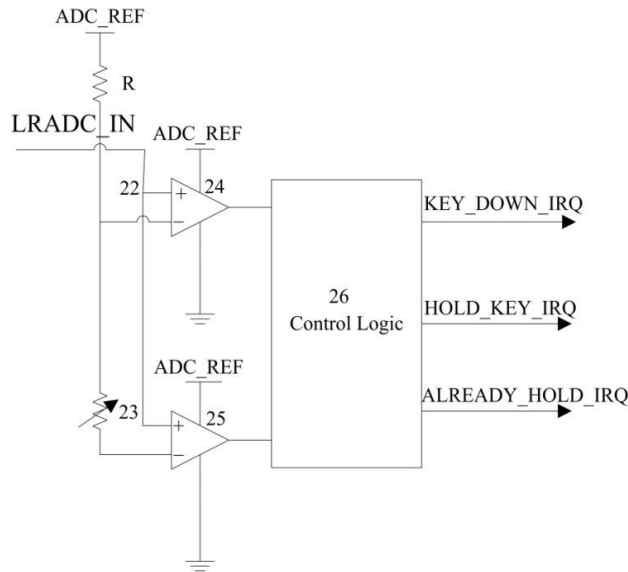

Figure 4-9. LRADC Data Converted Diagram

When ADC\_IN Signal change from 3.0V to less than 2.0V (Level A), the comparator24 send first interrupt to control logic; When ADC\_IN Signal change from 2.0V to less than certain level (Program can set), the comparator25 give second interrupt. If the control Logic get the first interrupt, In a certain time range (program can set), doesn't get second interrupt, it will send hold key interrupt to the host; If the control Logic get the first interrupt, In a certain time range (program can set), get second interrupt, it will send key down interrupt to the host; If the control logic only get the second interrupt, doesn't get the first interrupt, it will send already hold interrupt to the host.

The LRADC have three mode, Normal Mode、 Single Mode and Continue Mode. Normal mode is that the LRADC will report the result data of each convert all the time when the key is down. Single Mode is that the LRADC will only report the first convert result data when the key is down. Continue Mode is that the LRADC will report one of  $8*(N+1)$  (N is program can set) sample convert result data when key is down.

The LRADC is support four sample rate such as 250Hz、 125Hz、 62.5Hz and 32.25Hz, you can configure the value of LRADC\_SAMPLE\_RATE to select the fit sample rate.

#### 4.11.4. LRADC Register List

Module Name	Base Address
LRADC	0x01C22800

Register Name	Offset	Description
LRADC_CTRL	0x00	LRADC Control Register
LRADC_INTC	0x04	LRADC Interrupt Control Register
LRADC_INTS	0x08	LRADC Interrupt Status Register
LRADC_DATA0	0x0C	LRADC Data0 Register

### 4.11.5. LRADC Register Description

#### 4.11.5.1. LRADC Control Register (Default Value: 0x01000168)

Offset: 0x00			Register Name: LRADC_CTRL_REG
Bit	R/W	Default/Hex	Description
31: 24	R/W	0x1	FIRST_CONVERT_DLY. ADC First Convert Delay setting, ADC conversion is delayed by n samples
23:22	R/W	0x0	Reserved to 0
21:20	/	/	/
19:16	R/W	0x0	CONTINUE_TIME_SELECT. Continue Mode time select, one of 8*(N+1) sample as a valuable sample data
15:14	/	/	/
13:12	R/W	0x0	KEY_MODE_SELECT. Key Mode Select: 00: Normal Mode 01: Single Mode 10: Continue Mode
11:8	R/W	0x1	LEVELA_B_CNT. Level A to Level B time threshold select, judge ADC convert value in level A to level B in n+1 samples
7	R/W	0x0	LRADC_HOLD_KEY_EN LRADC Hold Key Enable 0: Disable 1: Enable
6	R/W	0x1	LRADC_HOLD_EN. LRADC Sample hold Enable 0: Disable 1: Enable
5: 4	R/W	0x2	LEVELB_VOL. Level B Corresponding Data Value setting (the real voltage value) 00: 0x3C (~1.9v) 01: 0x39 (~1.8v) 10: 0x36 (~1.7v) 11: 0x33 (~1.6v)
3: 2	R/W	0x2	LRADC_SAMPLE_RATE. LRADC Sample Rate 00: 250 Hz 01: 125 Hz 10: 62.5 Hz 11: 32.25 Hz
1	/	/	/
0	R/W	0x0	LRADC_EN.

			LRADC enable 0: Disable 1: Enable
--	--	--	---

#### 4.11.5.2. LRADC Interrupt Control Register (Default Value: 0x00000000)

Offset: 0x04			Register Name: LRADC_INTC_REG
Bit	R/W	Default/Hex	Description
31:5	/	/	/
4	R/W	0x0	ADC0_KEYUP_IRQ_EN. ADC0 Key Up IRQ Enable 0: Disable 1: Enable
3	R/W	0x0	ADC0_ALRDY_HOLD_IRQ_EN. ADC0 Already Hold IRQ Enable 0: Disable 1: Enable
2	R/W	0x0	ADC0_HOLD_IRQ_EN. ADC0 Hold Key IRQ Enable 0: Disable 1: Enable
1	R/W	0x0	ADC0_KEYDOWN_EN ADC0 Key Down Enable 0: Disable 1: Enable
0	R/W	0x0	ADC0_DATA_IRQ_EN. ADC0 Data IRQ Enable 0: Disable 1: Enable

#### 4.11.5.3. LRADC Interrupt Status Register (Default Value: 0x00000000)

Offset: 0x08			Register Name: LRADC_INTS_REG
Bit	R/W	Default/Hex	Description
31:5	/	/	/
4	R/W	0x0	ADC0_KEYUP_PENDING. ADC0 Key up Pending Bit When general key pull up, it the corresponding interrupt is enabled. 0: No IRQ 1: IRQ Pending <b>Notes:</b> Writing 1 to the bit will clear it and its corresponding interrupt if the interrupt is enable



3	R/W	0x0	<p>ADC0_ALRDY_HOLD_PENDING. ADC0 Already Hold Pending Bit</p> <p>When hold key pull down and pull the general key down, if the corresponding interrupt is enabled.</p> <p>0: No IRQ 1: IRQ Pending</p> <p><b>Notes:</b> Writing 1 to the bit will clear it and its corresponding interrupt if the interrupt is enable</p>
2	R/W	0x0	<p>ADC0_HOLDKEY_PENDING. ADC0 Hold Key Pending Bit</p> <p>When Hold key pull down, the status bit is set and the interrupt line is set if the corresponding interrupt is enabled.</p> <p>0: NO IRQ 1: IRQ Pending</p> <p><b>Notes:</b> Writing 1 to the bit will clear it and its corresponding interrupt if the interrupt is enable.</p>
1	R/W	0x0	<p>ADC0_KEYDOWN_PENDING. ADC0 Key Down IRQ Pending Bit</p> <p>When General key pull down, the status bit is set and the interrupt line is set if the corresponding interrupt is enabled.</p> <p>0: No IRQ 1: IRQ Pending</p> <p><b>Notes:</b> Writing 1 to the bit will clear it and its corresponding interrupt if the interrupt is enable.</p>
0	R/W	0x0	<p>ADC0_DATA_PENDING. ADC0 Data IRQ Pending Bit</p> <p>0: No IRQ 1: IRQ Pending</p> <p><b>Notes:</b> Writing 1 to the bit will clear it and its corresponding interrupt if the interrupt is enable.</p>

#### 4.11.5.4. LRADC Data0 Register (Default Value: 0x00000000)

Offset: 0x0C			Register Name: <b>LRADC_DATA0_REG</b>
Bit	R/W	Default/Hex	Description
31:6	/	/	/
5:0	R	0x0	LRADC_DATA0. LRADC Data0

## 4.12. RTC

### 4.12.1. Overview

The real time clock (RTC) is for calendar usage. It is built around a 30-bit counter and used to count elapsed time in YY-MM-DD and HH-MM-SS. The unit can be operated by the backup battery while the system power is off. It has a built-in leap year generator and a independent power pin (RTC\_VIO).

The alarm generates an alarm signal at a specified time in the power-off mode or normal operation mode. In normal operation mode, both the alarm interrupt and the power management wakeup are activated. In power-off mode, the power management wakeup signal is activated. In this section, there are two kinds of alarm. Alarm 0 is a general alarm, its counter is based on second. Alarm 1 is a weekly alarm, its counter is based on the real time.

The 32768Hz oscillator is used only to provide a low power, accurate reference for the RTC.

General Purpose Register can be flag register, and it will save the value all the time when the VDD\_RTC is not power off.

### 4.12.2. RTC Register List

Module Name	Base Address
RTC	0x01c20400

Register Name	Offset	Description
LOSC_CTRL_REG	0x0	Low Oscillator Control Register I
LOSC_AUTO_SWT_STA_REG	0x4	LOSC Auto Switch Status Register
RTC_YY_MM_DD_REG	0x10	RTC Year-Month-Day Register
RTC_HH_MM_SS_REG	0x14	RTC Hour-Minute-Second Register
ALARM0_COUNTER_REG	0x20	Alarm 0 Counter Register
ALARM0_CUR_VLU_REG	0x24	Alarm 0 Counter Current Value Register
ALARM0_ENABLE_REG	0x28	Alarm 0 Enable Register
ALARM0_IRQ_EN	0x2C	Alarm 0 IRQ Enable Register
ALARM0_IRQ_STA_REG	0x30	Alarm 0 IRQ Status Register
ALARM1_WK_HH_MM-SS	0x40	Alarm 1 Week HMS Register
ALARM1_ENABLE_REG	0x44	Alarm 1 Enable Register
ALARM1_IRQ_EN	0x48	Alarm 1 IRQ Enable Register
ALARM1_IRQ_STA_REG	0x4C	Alarm 1 IRQ Status Register
ALARM_CONFIG_REG	0x50	Alarm Config Register
LOSC_OUT_GATING_REG	0x60	LOSC output gating register
GP_DATA_REG	0x100 + N*0x4	General Purpose Register (N=0~7)

VDD_RTC_REG	0x190	VDD RTC Regulate Register
IC_CHARA_REG	0x1F0	IC Characteristic Register

### 4.12.3. RTC Register Description

#### 4.12.3.1. LOSC Control Register (Default Value: 0x00004000)

Offset: 0x00			Register Name: <b>LOSC_CTRL_REG</b>
Bit	R/W	Default/Hex	Description
31:16	W	0x0	KEY_FIELD. Key Field. This field should be filled with 0x16AA, and then the bit 0 can be written with the new value.
15	/	/	/
14	R/W	0x1	LOSC_AUTO_SWT_EN. LOSC auto switch enable. 0: Disable, 1: Enable.
13:10	/	/	/
9	R/W	0x0	ALM_DDHHMMSS_ACCE. ALARM DD-HH-MM-SS access. After writing the ALARM DD-HH-MM-SS register, this bit is set and it will be cleared until the real writing operation is finished.
8	R/W	0x0	RTC_HHMMSS_ACCE. RTC HH-MM-SS access. After writing the RTC HH-MM-SS register, this bit is set and it will be cleared until the real writing operation is finished. After writing the RTC YY-MM-DD register, the YY-MM-DD register will be refreshed for at most one second.
7	R/W	0x0	RTC_YMMDD_ACCE. RTC YY-MM-DD access. After writing the RTC YY-MM-DD register, this bit is set and it will be cleared until the real writing operation is finished. After writing the RTC YY-MM-DD register, the YY-MM-DD register will be refreshed for at most one second.
6:4	/	/	/
3:2	R/W	0x0	EXT_LOSC_GSM. External 32768Hz Crystal GSM. 00 low 01 10 11 high
1	/	/	/
0	R/W	0x0	LOSC_SRC_SEL. LOSC Clock source Select. 'N' is the value of Internal OSC Clock Prescaler

			register. 0: Internal 32KHz, 1: External 32.768KHz OSC. Note: Internal 32KHz is divided from OSC24MHz.
--	--	--	--

**Note1:** Any bit of [9:7] is set, the RTC HH-MM-SS, YY-MM-DD and ALARM DD-HH-MM-SS register can't be written .

**4.12.3.2. LOSC Auto Swith Status Register (Default Value: 0x00000000)**

Offset: 0x04			Register Name: LOSC_AUTO_SWT_STA_REG
Bit	R/W	Default/Hex	Description
31:2	/	/	/
1	R/W	0x0	LOSC_AUTO_SWT_PEND. LOSC auto switch pending. 0: No effect 1: Auto switches pending Set 1 to this bit will clear it.
0	RO	0x0	LOSC_SRC_SEL_STA. Checking LOSC Clock Source Status. 'N' is the value of Internal OSC Clock Prescalar register. 0: Internal 32KHz 1: External 32.768KHz OSC

**4.12.3.3. RTC YY-MM-DD Register (Default Value: 0x00000000)**

Offset: 0x10			Register Name: RTC_YY_MM_DD_REG
Bit	R/W	Default/Hex	Description
31:23	/	/	/
22	R/W	0x0	LEAP. Leap Year. 0: not, 1: Leap year. This bit can not set by hardware. It should be set or clear by software.
21:16	R/W	x	YEAR. Year. Range from 0~63.
15:12	/	/	/
11:8	R/W	x	MONTH. Month. Range from 1~12.
7:5	/	/	/
4:0	R/W	x	DAY. Day. Range from 1~31.

**Note1:** If the written value is not from 1 to 31 in Day Area, it turns into 31 automatically. Month Area and Year Area are similar to Day Area.

**Note2:** The number of days in different month may be different.

**4.12.3.4. RTC HH-MM-SS Register (Default Value: 0x00000000)**

Offset: 0x14			Register Name: <b>RTC_HH_MM_SS_REG</b>
Bit	R/W	Default/Hex	Description
31:29	R/W	0x0	WK_NO. Week number. 000: Monday 001: Tuesday 010: Wednesday 011: Thursday 100: Friday 101: Saturday 110: Sunday 111: /
28:21	/	/	/
20:16	R/W	x	HOUR. Range from 0~23
15:14	/	/	/
13:8	R/W	x	MINUTE. Range from 0~59
7:6	/	/	/
5:0	R/W	x	SECOND. Range from 0~59

**Note:** If the written value is not from 0 to 59 in Second Area, it turns into 59 automatically. Minute Area and Hour Area are similar to Second Area.

**4.12.3.5. Alarm 0 Counter Register (Default Value: 0x00000000)**

Offset: 0x20			Register Name: <b>ALARM0_COUNTER_REG</b>
Bit	R/W	Default/Hex	Description
31:0	R/W	0x0	ALARM0_COUNTER. Alarm 0 Counter is Based on Second.

**Note:** If the second is set to 0, it will be 1 second in fact.

**4.12.3.6. Alarm 0 Current Value Register (Default Value: 0x00000000)**

Offset: 0x24			Register Name: <b>ALARM0_CUR_VLU_REG</b>
Bit	R/W	Default/Hex	Description
31:0	RO	x	ALARM0_CUR_VLU. Check Alarm 0 Counter Current Values.

**Note:** If the second is set to 0, it will be 1 second in fact.

**4.12.3.7. Alarm 0 Enable Register (Default Value: 0x00000000)**

Offset: 0x28			Register Name: <b>ALARM0_ENABLE_REG</b>
Bit	R/W	Default/Hex	Description
31:1	/	/	/
0	R/W	0x0	ALM_0_EN Alarm 0 Enable. If this bit is set to “1”, the Alarm 0 Counter register’s valid bits will down count to zero, and the alarm pending bit will be set to “1”. 0: Disable 1: Enable

**4.12.3.8. Alarm 0 IRQ Enable Register (Default Value: 0x00000000)**

Offset: 0x2C			Register Name: <b>ALARM0_IRQ_EN_REG</b>
Bit	R/W	Default/Hex	Description
31:1	/	/	/
0	R/W	0x0	ALARM0_IRQ_EN. Alarm 0 IRQ Enable. 0: Disable 1: Enable

**4.12.3.9. Alarm 0 IRQ Status Register (Default Value: 0x00000000)**

Offset: 0x30			Register Name: <b>ALARM0_IRQ_STA_REG</b>
Bit	R/W	Default/Hex	Description
31:1	/	/	/
0	R/W	0x0	ALARM0_IRQ_PEND. Alarm 0 IRQ Pending bit. 0: No effect 1: Pending, alarm 0 counter value is reached

			If alarm 0 irq enable is set to 1, the pending bit will be sent to the interrupt controller.
--	--	--	--

**4.12.3.10. Alarm 1 Week HH-MM-SS Register (Default Value: 0x00000000)**

Offset: 0x40			Register Name: <b>ALARM0_WK_HH_MM-SS</b>
Bit	R/W	Default/Hex	Description
31:21	/	/	/
20:16	R/W	x	HOUR. Range from 0~23.
15:14	/	/	/
13:8	R/W	x	MINUTE. Range from 0~59.
7:6	/	/	/
5:0	R/W	x	SECOND. Range from 0~59.

**Note:** If the written value is not from 0 to 59 in Second Area, it turns into 59 automatically. Minute Area and Hour Area are similar to Second Area.

**4.12.3.11. Alarm 1 Enable Register (Default Value: 0x00000000)**

Offset: 0x44			Register Name: <b>ALARM1_EN_REG</b>
Bit	R/W	Default/Hex	Description
31:7	/	/	/
6	R/W	0x0	WK6_ALM1_EN. Week 6 (Sunday) Alarm 1 Enable. 0: Disable 1: Enable If this bit is set to "1", only when the Alarm 1 Week HH-MM-SS register valid bits is equal to RTC HH-MM-SS register and the register RTC HH-MM-SS bit [31:29] is 6, the week 6 alarm irq pending bit will be set to "1".
5	R/W	0x0	WK5_ALM1_EN. Week 5 (Saturday) Alarm 1 Enable. 0: Disable 1: Enable If this bit is set to "1", only when the Alarm 1 Week HH-MM-SS register valid bits is equal to RTC HH-MM-SS register and the register RTC HH-MM-SS bit [31:29] is 5, the week 5 alarm irq pending bit will be set to "1".
4	R/W	0x0	WK4_ALM1_EN. Week 4 (Friday) Alarm 1 Enable. 0: Disable

			<p>1: Enable</p> <p>If this bit is set to “1”, only when the Alarm 1 Week HH-MM-SS register valid bits is equal to RTC HH-MM-SS register and the register RTC HH-MM-SS bit [31:29] is 4, the week 4 alarm irq pending bit will be set to “1”.</p>
3	R/W	0x0	<p>WK3_ALM1_EN.</p> <p>Week 3 (Thursday) Alarm 1 Enable.</p> <p>0: Disable</p> <p>1: Enable</p> <p>If this bit is set to “1”, only when the Alarm 1 Week HH-MM-SS register valid bits is equal to RTC HH-MM-SS register and the register RTC HH-MM-SS bit [31:29] is 3, the week 3 alarm irq pending bit will be set to “1”.</p>
2	R/W	0x0	<p>WK2_ALM1_EN.</p> <p>Week 2 (Wednesday) Alarm 1 Enable.</p> <p>0: Disable</p> <p>1: Enable</p> <p>If this bit is set to “1”, only when the Alarm 1 Week HH-MM-SS register valid bits is equal to RTC HH-MM-SS register and the register RTC HH-MM-SS bit [31:29] is 2, the week 2 alarm irq pending bit will be set to “1”.</p>
1	R/W	0x0	<p>WK1_ALM1_EN.</p> <p>Week 1 (Tuesday) Alarm 1 Enable.</p> <p>0: Disable</p> <p>1: Enable</p> <p>If this bit is set to “1”, only when the Alarm 1 Week HH-MM-SS register valid bits is equal to RTC HH-MM-SS register and the register RTC HH-MM-SS bit [31:29] is 1, the week 1 alarm irq pending bit will be set to “1”.</p>
0	R/W	0x0	<p>WK0_ALM1_EN.</p> <p>Week 0 (Monday) Alarm 1 Enable.</p> <p>0: Disable</p> <p>1: Enable</p> <p>If this bit is set to “1”, only when the Alarm 1 Week HH-MM-SS register valid bits is equal to RTC HH-MM-SS register and the register RTC HH-MM-SS bit [31:29] is 0, the week 0 alarm irq pending bit will be set to “1”.</p>

#### 4.12.3.12. Alarm 1 IRQ Enable Register (Default Value: 0x00000000)

Offset: 0x48			Register Name: <b>ALARM1_IRQ_EN_REG</b>
Bit	R/W	Default/Hex	Description
31:1	/	/	/
0	R/W	0x0	<p>ALARM1_IRQ_EN.</p> <p>Alarm 1 IRQ Enable.</p> <p>0: Disable</p> <p>1: Enable</p>



**4.12.3.13. Alarm 1 IRQ Status Register (Default Value: 0x00000000)**

Offset: 0x4C			Register Name: <b>ALARM1_IRQ_STA_REG</b>
Bit	R/W	Default/Hex	Description
31:1	/	/	/
0	R/W	0x0	ALARM1_WEEK_IRQ_PEND. Alarm 1 Week (0/1/2/3/4/5/6) IRQ Pending. 0: No effect 1: Pending, week counter value is reached If alarm 1 week irq enable is set to 1, the pending bit will be sent to the interrupt controller.

**4.12.3.14. Alarm Config Register (Default Value: 0x00000000)**

Offset: 0x50			Register Name: <b>ALARM_CONFIG_REG</b>
Bit	R/W	Default/Hex	Description
31:1	/	/	/
0	R/W	0x0	ALARM_WAKEUP. Configuration of alarm wake up output. 0: Disable alarm wake up output 1: Enable alarm wake up output

**4.12.3.15. LOSC Output Gating Register (Default Value: 0x00000000)**

Offset: 0x60			Register Name: <b>LOSC_OUT_GATING_REG</b>
Bit	R/W	Default/Hex	Description
31:1	/	/	/
0	R/W	0x0	LOSC_OUT_GATING. Configuration of LOSC output, and no LOSC output by default. 0: Enable LOSC output gating 1: Disable LOSC output gating

**4.12.3.16. LOSC Output Gating Register (Default Value: 0x00000000)**

Offset: 0x100+N*0x4(N=0~7)			Register Name: <b>GP_DATA_REGn</b>
Bit	R/W	Default/Hex	Description
31:0	R/W	0x0	GP_DATA. Data [31:0].

**Note:** General purpose register 0~7 value can be stored if the VDD\_RTC is larger than 1.0v

**4.12.3.17. VDD RTC Regulation Register (Default Value: 0x00000004)**

Offset: 0x190			Register Name: <b>VDD_RTC_REG</b>
Bit	R/W	Default/Hex	Description
31:3	/	/	/
2:0	R/W	0x100	VDD_RTC_REGU. These bits are useful for regulating the RTC_VIO from 0.7v to 1.4v, and the regulation step is 0.1v. 000: 0.7v 001: 0.8v 010: 0.9v 011: 1.0v 100: 1.1v 101: 1.2v 110: 1.3v 111: 1.4v

**4.12.3.18. IC Characteristic Register (Default Value: 0x00000000)**

Offset: 0x1F0			Register Name: <b>IC_CHARA_REG</b>
Bit	R/W	Default/Hex	Description
31:16	R/W	0x0	IC_CHARA. Key Field. Should be written at value 0x16AA. Writing any other value in this field aborts the write operation.
15:0	R/W	0x0	ID_DATA. Return 0x16aa only if the KEY_FIELD is set as 0x16aa when read those bits, otherwise return 0x0.

## 4.13. Audio Codec

### 4.13.1. Overview

The embedded Audio Codec is a high-quality stereo audio codec designed for embed device. It provides a stereo DAC for playback, and a stereo ADC for recording.

The feature of Audio Codec:

- Two audio digital-to-analog(DAC) channels
- Support analog/ digital volume control
- One low-noise analog microphone bias output
- Analog low-power loop from microphone to headphone outputs
- Support Dynamic Range Controller adjusting the DAC playback output
- One differential microphone input
- One Stereo Headphone output
- Two audio analog-to-digital(ADC) channels
  - 92dB SNR@A-weight
  - Supports ADC Sample Rates from 8KHz to 48KHz
- Support Automatic Gain Control(AGC) and Dynamic Range Control(DRC) adjusting the ADC recording input
- Interrupt and DMA Support

### 4.13.2. Power and Signal Description

#### 4.13.2.1. Analog I/O Pins

Signal Name	Type	Description
MIC1P	I	First microphone positive input
MIC1N	I	First microphone negative input
HPOUTL	O	Headphone left output
HPOUTR	O	Headphone right output
HPCOM	O	HPCOM output
HPCOMFB	I	HPCOM feedback input

#### 4.13.2.2. Filter/Reference

HBIAS	O	Bias voltage output for headphone
VRA1	O	internal reference voltage
VRA2	O	internal reference voltage

HPVCCBP	O	HPVCC By Pass
---------	---	---------------

**4.13.2.3. Power/Ground**

AVCC	P	Analog power
HPVCCIN	P	Headphone Amplifier Power
AGND	G	Analog ground

**4.13.3. Data Path Diagram**

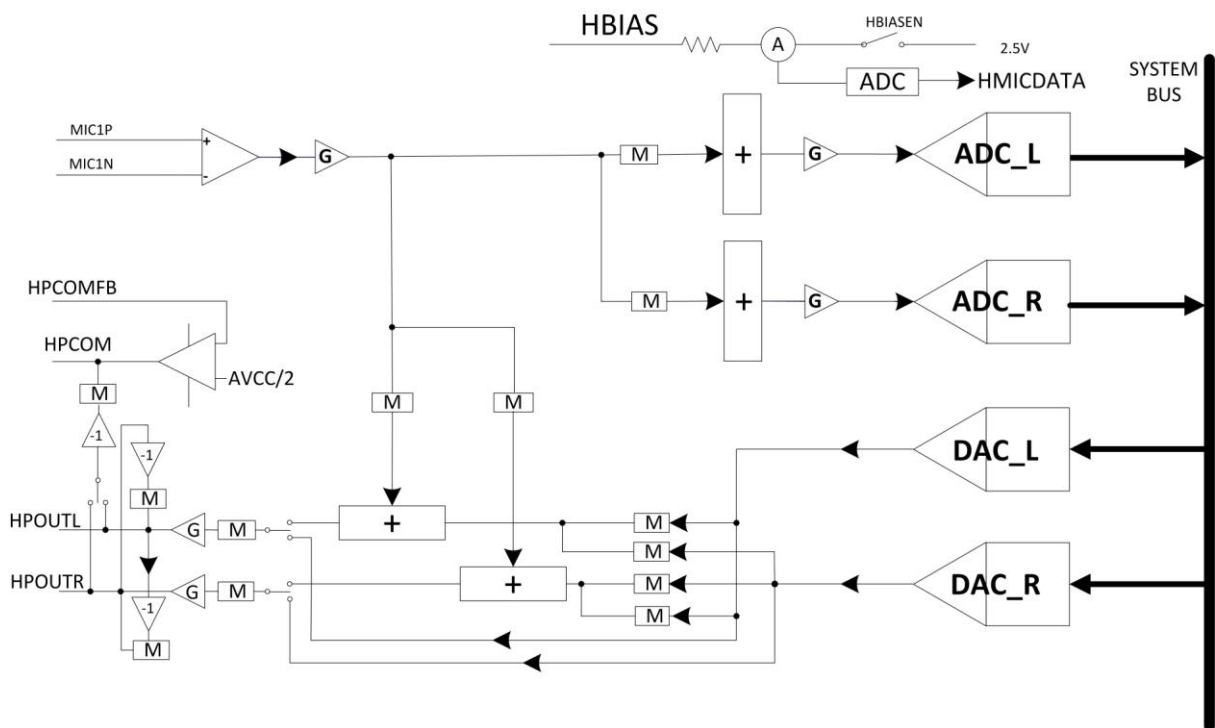

Figure 4-10. Analog Data Path Diagram

**4.13.4. Audio Codec Register List**

Module Name	Base Address
AC	0x01c22c00

Register Name	Offset	Description
AC_DAC_DPC	0x000	DAC Digital Part Control Register
AC_DAC_FIFOC	0x004	DAC FIFO Control Register
AC_DAC_FIFOS	0x008	DAC FIFO Status Register

AC_ADC_FIFOC	0x010	ADC FIFO Control Register
AC_ADC_FIFOS	0x014	ADC FIFO Status Register
AC_ADC_RXDATA	0x018	ADC RX Data Register
AC_DAC_TXDATA	0x020	DAC TX Data Register
AC_DAC_CNT	0x040	DAC TX FIFO Counter Register
AC_ADC_CNT	0x044	ADC RX FIFO Counter Register
AC_DAC_DG	0x048	DAC Debug Register
AC_ADC_DG	0x04C	ADC Debug Register
AC_DAC_DAP_CTR	0x060	DAC DAP Control Register
AC_ADC_DAP_CTR	0x070	ADC DAP Control Register
AC_ADC_DAP_LCTR	0x074	ADC DAP Left Control Register
AC_ADC_DAP_RCTR	0x078	ADC DAP Right Control Register
AC_ADC_DAP_PARA	0x07C	ADC DAP Parameter Register
AC_ADC_DAP_LAC	0x080	ADC DAP Left Average Coef Register
AC_ADC_DAP_LDAT	0x084	ADC DAP Left Decay and Attack Time Register
AC_ADC_DAP_RAC	0x088	ADC DAP Right Average Coef Register
AC_ADC_DAP_RDAT	0x08C	ADC DAP Right Decay and Attack Time Register
ADC_DAP_HPFC	0x090	ADC DAP HPF Coef Register
ADC_DAP_LINAC	0x094	ADC DAP Left Input Signal Low Average Coef Register
ADC_DAP_RINAC	0x098	ADC DAP Right Input Signal Low Average Coef Register
ADC_DAP_ORT	0x09C	ADC DAP Optimum Register
AC_DAC_DRC_HHPFC	0x100	DAC DRC High HPF Coef Register
AC_DAC_DRC_LHPFC	0x104	DAC DRC Low HPF Coef Register
AC_DAC_DRC_CTRL	0x108	DAC DRC Control Register
AC_DAC_DRC_LPFHAT	0x10C	DAC DRC Left Peak Filter High Attack Time Coef Register
AC_DAC_DRC_LPFLAT	0x110	DAC DRC Left Peak Filter Low Attack Time Coef Register
AC_DAC_DRC_RPFHAT	0x114	DAC DRC Right Peak Filter High Attack Time Coef Register
AC_DAC_DRC_RPFLAT	0x118	DAC DRC Peak Filter Low Attack Time Coef Register
AC_DAC_DRC_LPFHRT	0x11C	DAC DRC Left Peak Filter High Release Time Coef Register
AC_DAC_DRC_LPFLRT	0x120	DAC DRC Left Peak Filter Low Release Time Coef Register
AC_DAC_DRC_RPFHRT	0x124	DAC DRC Right Peak filter High Release Time Coef Register
AC_DAC_DRC_RPFLRT	0x128	DAC DRC Right Peak filter Low Release Time Coef Register
AC_DAC_DRC_LRMSHAT	0x12C	DAC DRC Left RMS Filter High Coef Register
AC_DAC_DRC_LRMSLAT	0x130	DAC DRC Left RMS Filter Low Coef Register
AC_DAC_DRC_RRMSHAT	0x134	DAC DRC Right RMS Filter High Coef Register
AC_DAC_DRC_RRMSLAT	0x138	DAC DRC Right RMS Filter Low Coef Register
AC_DAC_DRC_HCT	0x13C	DAC DRC Compressor Theshold High Setting Register
AC_DAC_DRC_LCT	0x140	DAC DRC Compressor Slope High Setting Register
AC_DAC_DRC_HKC	0x144	DAC DRC Compressor Slope High Setting Register
AC_DAC_DRC_LKC	0x148	DAC DRC Compressor Slope Low Setting Register

AC_DAC_DRC_HOPC	0x14C	DAC DRC Compressor High Output at Compressor Threshold Register
AC_DAC_DRC_LOPC	0x150	DAC DRC Compressor Low Output at Compressor Threshold Register
AC_DAC_DRC_HLT	0x154	DAC DRC Limiter Theshold High Setting Register
AC_DAC_DRC_LLT	0x158	DAC DRC Limiter Theshold Low Setting Register
AC_DAC_DRC_HKI	0x15C	DAC DRC Limiter Slope High Setting Register
AC_DAC_DRC_LKI	0x160	DAC DRC Limiter Slope Low Setting Register
AC_DAC_DRC_HOPL	0x164	DAC DRC Limiter High Output at Limiter Threshold
AC_DAC_DRC_LOPL	0x168	DAC DRC Limiter Low Output at Limiter Threshold
AC_DAC_DRC_HET	0x16C	DAC DRC Expander Theshold High Setting Register
AC_DAC_DRC_LET	0x170	DAC DRC Expander Theshold Low Setting Register
AC_DAC_DRC_HKE	0x174	DAC DRC Expander Slope High Setting Register
AC_DAC_DRC_LKE	0x178	DAC DRC Expander Slope Low Setting Register
AC_DAC_DRC_HOPE	0x17C	DAC DRC Expander High Output at Expander Threshold
AC_DAC_DRC_LOPE	0x180	DAC DRC Expander Low Output at Expander Threshold
AC_DAC_DRC_HKN	0x184	DAC DRC Linear Slope High Setting Register
AC_DAC_DRC_LKN	0x188	DAC DRC Linear Slope Low Setting Register
AC_DAC_DRC_SFHAT	0x18C	DAC DRC Smooth filter Gain High Attack Time Coef Register
AC_DAC_DRC_SFLAT	0x190	DAC DRC Smooth filter Gain Low Attack Time Coef Register
AC_DAC_DRC_SFHRT	0x194	DAC DRC Smooth filter Gain High Release Time Coef Register
AC_DAC_DRC_SFLRT	0x198	DAC DRC Smooth filter Gain Low Release Time Coef Register
AC_DAC_DRC_MXGHS	0x19C	DAC DRC MAX Gain High Setting Register
AC_DAC_DRC_MXGLS	0x1A0	DAC DRC MAX Gain Low Setting Register
AC_DAC_DRC_MNGHS	0x1A4	DAC DRC MIN Gain High Setting Register
AC_DAC_DRC_MNGLS	0x1A8	DAC DRC MIN Gain Low Setting Register
AC_DAC_DRC_EPSHC	0x1AC	DAC DRC Expander Smooth Time High Coef Register
AC_DAC_DRC_EPSLC	0x1B0	DAC DRC Expander Smooth Time Low Coef Register
/	0x1B4	/
AC_DAC_DRC_HPFHGAIN	0x 1B8	DAC DRC HPF Gain High
AC_DAC_DRC_HPFLGAIN	0x1BC	DAC DRC HPF Gain Low
AC_ADC_DRC_HHPFC	0x200	ADC DRC High HPF Coef Register
AC_ADC_DRC_LHPFC	0x204	ADC DRC Low HPF Coef Register
AC_ADC_DRC_CTRL	0x208	ADC DRC Control Register
AC_ADC_DRC_LPFHAT	0x20C	ADC DRC Left Peak Filter High Attack Time Coef Register
AC_ADC_DRC_LPFLAT	0x210	ADC DRC Left Peak Filter Low Attack Time Coef Register
AC_ADC_DRC_RPFHAT	0x214	ADC DRC Right Peak Filter High Attack Time Coef Register
AC_ADC_DRC_RPFLAT	0x218	ADC DRC Peak Filter Low Attack Time Coef Register
AC_ADC_DRC_LPFHRT	0x21C	ADC DRC Left Peak Filter High Release Time Coef Register
AC_ADC_DRC_LPFLRT	0x220	ADC DRC Left Peak Filter Low Release Time Coef Register
AC_ADC_DRC_RPFHRT	0x224	ADC DRC Right Peak filter High Release Time Coef Register
AC_ADC_DRC_RPFLRT	0x228	ADC DRC Right Peak filter Low Release Time Coef Register

AC_ADC_DRC_LRMSHAT	0x22C	ADC DRC Left RMS Filter High Coef Register
AC_ADC_DRC_LRMSLAT	0x230	ADC DRC Left RMS Filter Low Coef Register
AC_ADC_DRC_RRMSHAT	0x234	ADC DRC Right RMS Filter High Coef Register
AC_ADC_DRC_RRMSLAT	0x238	ADC DRC Right RMS Filter Low Coef Register
AC_ADC_DRC_HCT	0x23C	ADC DRC Compressor Theshold High Setting Register
AC_ADC_DRC_LCT	0x240	ADC DRC Compressor Slope High Setting Register
AC_ADC_DRC_HKC	0x244	ADC DRC Compressor Slope High Setting Register
AC_ADC_DRC_LKC	0x248	ADC DRC Compressor Slope Low Setting Register
AC_ADC_DRC_HOPC	0x24C	ADC DRC Compressor High Output at Compressor Threshold Register
AC_ADC_DRC_LOPC	0x250	ADC DRC Compressor Low Output at Compressor Threshold Register
AC_ADC_DRC_HLT	0x254	ADC DRC Limiter Theshold High Setting Register
AC_ADC_DRC_LLT	0x258	ADC DRC Limiter Theshold Low Setting Register
AC_ADC_DRC_HKI	0x25C	ADC DRC Limiter Slope High Setting Register
AC_ADC_DRC_LKI	0x260	ADC DRC Limiter Slope Low Setting Register
AC_ADC_DRC_HOPL	0x264	ADC DRC Limiter High Output at Limiter Threshold
AC_ADC_DRC_LOPL	0x268	ADC DRC Limiter Low Output at Limiter Threshold
AC_ADC_DRC_HET	0x26C	ADC DRC Expander Theshold High Setting Register
AC_ADC_DRC_LET	0x270	ADC DRC Expander Theshold Low Setting Register
AC_ADC_DRC_HKE	0x274	ADC DRC Expander Slope High Setting Register
AC_ADC_DRC_LKE	0x278	ADC DRC Expander Slope Low Setting Register
AC_ADC_DRC_HOPE	0x27C	ADC DRC Expander High Output at Expander Threshold
AC_ADC_DRC_LOPE	0x280	ADC DRC Expander Low Output at Expander Threshold
AC_ADC_DRC_HKN	0x284	ADC DRC Linear Slope High Setting Register
AC_ADC_DRC_LKN	0x288	ADC DRC Linear Slope Low Setting Register
AC_ADC_DRC_SFHAT	0x28C	ADC DRC Smooth filter Gain High Attack Time Coef Register
AC_ADC_DRC_SFLAT	0x290	ADC DRC Smooth filter Gain Low Attack Time Coef Register
AC_ADC_DRC_SFHRT	0x294	ADC DRC Smooth filter Gain High Release Time Coef Register
AC_ADC_DRC_SFLRT	0x298	ADC DRC Smooth filter Gain Low Release Time Coef Register
AC_ADC_DRC_MXGHS	0x29C	ADC DRC MAX Gain High Setting Register
AC_ADC_DRC_MXGLS	0x2A0	ADC DRC MAX Gain Low Setting Register
AC_ADC_DRC_MNGLS	0x2A4	ADC DRC MIN Gain High Setting Register
AC_ADC_DRC_MXGLS	0x2A8	ADC DRC MIN Gain Low Setting Register
AC_ADC_DRC_EPSHC	0x2AC	ADC DRC Expander Smooth Time High Coef Register
AC_ADC_DRC_EPSLC	0x2B0	ADC DRC Expander Smooth Time Low Coef Register
/	0x2B4	/
AC_ADC_DRC_HPFHGAIN	0x 2B8	ADC DRC HPF Gain High
AC_ADC_DRC_HPFLGAIN	0x2BC	ADC DRC HPF Gain Low
AC_PR_CFG	0x400	AC Parameter Configuration Register
Analog domain Register		
AC_PAG_HPVC	0x00	PA clock gating and Headphone Volume Control

AC_LOMIXSC	0x01	Left Output Mixer Source Select Control Register
AC_ROMIXSC	0x02	Right Output Mixer Source Select Control Register
DAC_PA_SRC	0x03	DAC Analog Enable and PA Source Control Register
MIC_GCTR	0x06	MIC1 Gain Control Register
HP_CTRL	0x07	HP Control
BIAS_MIC_CTRL	0x0B	BIAS and MIC1 boost
LADC_MIX_MUTE	0x0C	Left ADC Mixer Mute Control
RADC_MIX_MUTE	0x0D	Right ADC Mixer Mute Control
PA_ANTI_POP_CTRL	0x0E	PA Anti-pop time Control
AC_ADC_CTRL	0x0F	ADC Analog Control Register
OPADC_CTRL	0x10	OPDRV/OPCOM 、OPADC Control
OPMIC_CTRL	0x11	OPMIC、OPVR and OPADC Control
ZERO_CROSS_CTRL	0x12	ZERO CROSS Control
ADC_FUN_CTRL	0x13	ADC Function Control
CALIBRATION_CTRL	0x14	Bias & DA16 Calibration Control Register
DA16CALI_DATA	0x15	DA16 Calibration Data
BIAS16CALI_DATA	0x17	Bias Calibration Data
BIAS16CALI_SET	0x18	Bias Register Setting Data

### 4.13.5. Audio Codec Register Description

#### 4.13.5.1. 0x000 DAC Digital Part Control Register(Default Value: 0x00000000)

Offset: 0x000			Register Name: AC_DAC_DPC
Bit	R/W	Default/Hex	Description
31	R/W	0x0	EN_DAC DAC Digital Part Enable 0 : Disable 1 : Enable
30:29	/	/	/
28:25	R/W	0x0	MODQU Internal DAC Quantization Levels Levels= $[7*(21+MODQU[3:0])]/128$ Default levels= $7*21/128=1.15$
24:19	/	/	/
18	R/W	0x0	HPF_EN High Pass Filter Enable 0: Disable 1: Enable
17:12	R/W	0x0	DVOL Digital volume control: DVC, ATT=DVC[5:0]*(-1.16Db) 64 steps, -1.16Db/step



11:0	/	/	/
------	---	---	---

**4.13.5.2. 0x004 DAC FIFO Control Register(Default Value: 0x00000F00)**

Offset: 0x004			Register Name: <b>AC_DAC_FIFOC</b>
Bit	R/W	Default/Hex	Description
31:29	R/W	0X0	DAC_FS Sample Rate Of DAC 000: 48KHz 010: 24KHz 100: 12KHz 110: 192KHz 001: 32KHz 011: 16KHz 101: 8KHz 111: 96KHz 44.1KHz/22.05KHz/11.025KHz can be supported by Audio PLL Configure Bit
28	R/W	0x0	FIR_VER FIR Version 0: 64-Tap FIR; 1: 32-Tap FIR
27	/	/	/
26	R/W	0x0	SEND_LASAT Audio sample select when TX FIFO under run 0: Sending zero 1: Sending last audio sample
25:24	R/W	0x0	FIFO_MODE For 24-bits transmitted audio sample: 00/10: FIFO_I[23:0] = {TXDATA[31:8]} 01/11: Reserved For 16-bits transmitted audio sample: 00/10: FIFO_I[23:0] = {TXDATA[31:16], 8'b0} 01/11: FIFO_I[23:0] = {TXDATA[15:0], 8'b0}
23	/	/	/
22:21	R/W	0X0	DAC_DRQ_CLR_CNT When TX FIFO Available Room Less Than Or Equal N, DRQ Request Will Be De-Asserted. N Is Defined Here: 00: IRQ/DRQ De-Asserted When WLEVEL > TXTL 01: 4 10: 8 11: 16
20:15	/	/	/
14:8	R/W	0XF	TX_TRIG_LEVEL TX FIFO Empty Trigger Level (TXTL[12:0]) Interrupt and DMA request trigger level for TX FIFO normal condition.

			IRQ/DRQ Generated when WLEVEL ≤ TXTL Notes: 1. WLEVEL represents the number of valid samples in the TX FIFO 2. Only TXTL[6:0] valid when TXMODE = 0
7	R/W	0X0	ADDA_LOOP_EN ADDA Loop Enable 0: Disable 1: Enable
6	R/W	0X0	DAC_MONO_EN DAC Mono Enable 0: Stereo, 64 Levels FIFO 1: Mono, 128 Levels FIFO When Enabled, L & R Channel Send Same Data
5	R/W	0X0	TX_SAMPLE_BITS Transmitting Audio Sample Resolution 0: 16 bits 1: 24 bits
4	R/W	0X0	DAC_DRQ_EN DAC FIFO Empty DRQ Enable 0: Disable 1: Enable
3	R/W	0X0	DAC_IRQ_EN DAC FIFO Empty IRQ Enable 0: Disable 1: Enable
2	R/W	0X0	FIFO_UNDERRUN_IRQ_EN DAC FIFO Under Run IRQ Enable 0: Disable 1: Enable
1	R/W	0X0	FIFO_OVERRUN_IRQ_EN DAC FIFO Over Run IRQ Enable 0: Disable 1: Enable
0	R/W	0X0	FIFO_FLUSH DAC FIFO Flush Write '1' To Flush TX FIFO, Self Clear to '0'

#### 4.13.5.3. 0x008 DAC FIFO Status Register(Default Value: 0x00800088)

Offset: 0x008			Register Name: <b>AC_DAC_FIFOS</b>
Bit	R/W	Default/Hex	Description
31:24	/	/	/
23	R	0x1	TX_EMPTY TX FIFO Empty

			0: No room for new sample in TX FIFO 1: More than one room for new sample in TX FIFO (>= 1 word)
22:8	R	0x80	TXE_CNT TX FIFO Empty Space Word Counter
7:4	/	/	/
3	R/W	0x1	TXE_INT TX FIFO Empty Pending Interrupt 0: No Pending IRQ 1: FIFO Empty Pending Interrupt Write '1' to clear this interrupt or automatic clear if interrupt condition fails
2	R/W	0x0	TXU_INT TX FIFO Under run Pending Interrupt 0: No Pending Interrupt 1: FIFO Under run Pending Interrupt Write '1' to clear this interrupt
1	R/W	0x0	TXO_INT TX FIFO Overrun Pending Interrupt 0: No Pending Interrupt 1: FIFO Overrun Pending Interrupt Write '1' to clear this interrupt
0	/	/	/

#### 4.13.5.4. 0x010 ADC FIFO Control Register(Default Value: 0x0000F00)

Offset: 0x010			Register Name: AC_ADC_FIFOC
Bit	R/W	Default/Hex	Description
31:29	R/W	0X0	ADFS Sample Rate of ADC 000: 48KHz 010: 24KHz 100: 12KHz 110: Reserved 001: 32KHz 011: 16KHz 101: 8KHz 111: Reserved 44.1KHz/22.05KHz/11.025KHz can be supported by Audio PLL Configure Bit
28	R/W	0X0	EN_AD ADC Digital Part Enable 0: Disable 1: Enable
27:25	/	/	/
24	R/W	0X0	RX_FIFO_MODE RX FIFO Output Mode (Mode 0, 1)

			<p>0: Expanding '0' at LSB of TX FIFO register  1: Expanding received sample sign bit at MSB of TX FIFO register</p> <p>For 24-bits received audio sample:  Mode 0: RXDATA[31:0] = {FIFO_O[23:0], 8'h0}  Mode 1: Reserved</p> <p>For 16-bits received audio sample:  Mode 0: RXDATA[31:0] = {FIFO_O[23:8], 16'h0}  Mode 1: RXDATA[31:0] = {16{FIFO_O[23]}, FIFO_O[23:8]}</p>
23:19	/	/	/
18:17	R/W	0X0	<p>ADCFDT  ADC FIFO Delay Time For writing Data after EN_AD</p> <p>00:5ms  01:10ms  10:20ms  11:30ms</p>
16	R/W	0X0	<p>ADCFDEN  ADC FIFO Delay Function For writing Data after EN_AD</p> <p>0: Disable  1: Enable</p>
15:13	/	/	/
12:8	R/W	0XF	<p>RX_FIFO_TRG_LEVEL  RX FIFO Trigger Level (RXTL[4:0])</p> <p>Interrupt and DMA request trigger level for RX FIFO normal condition  IRQ/DRQ Generated when WLEVEL &gt; RXTL[4:0]</p> <p>Notes:  WLEVEL represents the number of valid samples in the RX FIFO</p>
7	R/W	0X0	<p>ADC_MONO_EN  ADC Mono Enable</p> <p>0: Stereo, 16 levels FIFO  1: mono, 32 levels FIFO</p> <p>When set to '1', Only left channel samples are recorded</p>
6	R/W	0x0	<p>RX_SAMPLE_BITS  Receiving Audio Sample Resolution</p> <p>0: 16 bits  1: 24 bits</p>
5	/	/	/
4	R/W	0X0	<p>ADC_DRQ_EN  ADC FIFO Data Available DRQ Enable</p> <p>0: Disable  1: Enable</p>
3	R/W	0X0	<p>ADC_IRQ_EN  ADC FIFO Data Available IRQ Enable</p> <p>0: Disable  1: Enable</p>
2	/	/	

1	R/W	0X0	ADC_OVERRUN_IRQ_EN ADC FIFO Over Run IRQ Enable 0: Disable 1: Enable
0	R/W	0X0	ADC_FIFO_FLUSH ADC FIFO Flush Write '1' to flush TX FIFO, self clear to '0'

#### 4.13.5.5. 0x014 ADC FIFO Status Register(Default Value: 0x00000000)

Offset: 0x014			Register Name: <b>AC_ADC_FIFOS</b>
Bit	R/W	Default/Hex	Description
31:24	/	/	/
23	R	0X0	RXA RX FIFO Available 0: No available data in RX FIFO 1: More than one sample in RX FIFO (>= 1 word)
22:14	/	/	/
13:8	R	0X0	RXA_CNT RX FIFO Available Sample Word Counter
7:4	/	/	/
3	R/W	0X0	RXA_INT RX FIFO Data Available Pending Interrupt 0: No Pending IRQ 1: Data Available Pending IRQ Write '1' to clear this interrupt or automatic clear if interrupt condition fails
2	/	/	/
1	R/W	0X0	RXO_INT RX FIFO Overrun Pending Interrupt 0: No Pending IRQ 1: FIFO Overrun Pending IRQ Write '1' to clear this interrupt
0	/	/	/

#### 4.13.5.6. 0x018 ADC RX DATA Register(Default Value: 0x00000000)

Offset: 0x018			Register Name: <b>AC_ADC_RXDATA</b>
Bit	R/W	Default/Hex	Description
31:0	R	0X0	RX_DATA RX Sample Host can get one sample by reading this register. The left channel sample data is first and then the right channel sample.

**4.13.5.7. 0x020 DAC TX DATA Register(Default Value: 0x00000000)**

Offset: 0x020			Register Name: <b>AC_DAC_TXDATA</b>
Bit	R/W	Default/Hex	Description
31:0	W	0X0	TX_DATA Transmitting left, right channel sample data should be written this register one by one. The left channel sample data is first and then the right channel sample

**4.13.5.8. 0x040 DAC TX Counter Register(Default Value: 0x00000000)**

Offset: 0x040			Register Name: <b>AC_DAC_CNT</b>
Bit	R/W	Default/Hex	Description
31:0	R/W	0X0	TX_CNT TX Sample Counter The audio sample number of sending into TXFIFO. When one sample is put into TXFIFO by DMA or by host IO, the TX sample counter register increases by one. The TX sample counter register can be set to any initial value at any time. After been updated by the initial value, the counter register should count on base of this initial value Notes: It is used for Audio/ Video Synchronization

**4.13.5.9. 0x044 ADC RX Counter Register(Default Value: 0x00000000)**

Offset: 0x044			Register Name: <b>AC_ADC_CNT</b>
Bit	R/W	Default/Hex	Description
31:0	R/W	0X0	RX_CNT RX Sample Counter The audio sample number of writing into RXFIFO. When one sample is written by Digital Audio Engine, the RX sample counter register increases by one. The RX sample counter register can be set to any initial value at any time. After been updated by the initial value, the counter register should count on base of this initial value Notes: It is used for Audio/ Video Synchronization

**4.13.5.10. 0x048 DAC Debug Register(Default Value: 0x00000000)**

Offset: 0x048			Register Name: <b>AC_DAC_DG</b>
Bit	R/W	Default/Hex	Description
31:12	/	/	/

11	R/W	0X0	DAC_MODU_SELECT DAC Modulator Debug 0: DAC Modulator Normal Mode 1: DAC Modulator Debug Mode
10:9	R/W	0X0	DAC_PATTERN_SELECT. DAC Pattern Select 00: Normal (Audio Sample from TX FIFO) 01: -6 dB Sin wave 10: -60 dB Sin wave 11: silent wave
8	R/W	0X0	CODEC_CLK_SELECT CODEC Clock Source Select 0: CODEC Clock from PLL 1: CODEC Clock from OSC (For Debug)
7	/	/	/
6	R/W	0X0	DA_SWP DAC output channel swap enable 0:Disable 1:Enable
5:0	/	/	/

**4.13.5.11. 0x04C ADC Debug Register(Default Value: 0x00000000)**

Offset: 0x4C			Register Name: <b>AC_ADC_DG</b>
Bit	R/W	Default/Hex	Description
31:25	/	/	/
24	R/W	0X0	AD_SWP ADC Output Channel Swap Enable (for digital filter) 0: Disable 1: Enable
23:0	/	/	/

**4.13.5.12. 0x050 HMIC Control Register(Default Value: 0x00000000)**

Offset: 0x50			Register Name: <b>HMIC_CTRL</b>
Bit	R/W	Default/Hex	Description
31:28	R/W	0x0	HMIC_M Debounce when key down or key up
27:24	R/W	0x0	HMIC_N Debounce when earphone plug in or pull out
23	R/W	0x0	HMIC_DATA_IRQ_MODE Hmic Data Irq Mode Select

			0: Hmic data irq once after key down 1: Hmic data irq from key down, until key up
22:21	R/W	0x0	HMIC_TH1_HYSTERESIS Hmic Hysteresis Threshold1 00: no Hysteresis 01: Pull Out when Data <= (Hmic_th2-1) 10: Pull Out when Data <= (Hmic_th2-2) 11: Pull Out when Data <= (Hmic_th2-3)
20	R/W	0x0	HMIC_PULLOUT_IRQ Hmic Earphone Pull out Irq Enable 00: disable, 11: enable
19	R/W	0x0	HMIC_PLUGIN_IRQ Hmic Earphone Plug in Irq Enable 00: disable 11: enable
18	R/W	0x0	HMIC_KEYUP_IRQ Hmic Key Up Irq Enable 00: disable 11: enable
17	R/W	0x0	HMIC_KEYDOWN_IRQ Hmic Key Down Irq Enable 00: disable 11: enable
16	R/W	0x0	HMIC_DATA_IRQ_EN Hmic Data Irq Enable 00: disable 11: enable
15:14	R/W	0x0	HMIC_SAMPLE_SELECT Down Sample Setting Select 00: Down by 1, 128Hz 01: Down by 2, 64Hz 10: Down by 4, 32Hz 11: Down by 8, 16Hz
13	R/W	0x0	HMIC_TH2_HYSTERESIS Hmic Hysteresis Threshold2 0: no Hysteresis 1: Key Up when Data <= (Hmic_th2-1)
12:8	R/W	0x0	HMIC_TH2 Hmic_th2 for detecting Key down or Key up.
7:6	R/W	0x0	HMIC_SF Hmic Smooth Filter setting 00: by pass 01: $(x1+x2)/2$ 10: $(x1+x2+x3+x4)/4$ 11: $(x1+x2+x3+x4+ x5+x6+x7+x8)/8$
5	R/W	0x0	KEYUP_CLEAR Key Up Irq Pending bit auto clear when Key Down Irq 0: don't clear    1: auto clear
4:0	R/W	0x0	HMIC_TH1



			Hmic_th1[4:0], detecting eraphone plug in or pull out.
--	--	--	--

**4.13.5.13. 0x054 HMIC Data Register(Default Value: 0x00000000)**

Offset: 0x54			Register Name: <b>HMIC_DATA</b>
Bit	Read/Write	Default	Description
31:21	/	/	/
20	R/W	0x0	HMIC_PULLOUT_PENDING Hmic Earphone Pull out Irq pending bit, write 1 to clear 0: No Pending Interrupt 1: Pull out Irq Pending Interrupt
19	R/W	0x0	HMIC_PLUGIN_PENDING Hmic Earphone Plug in Irq pending bit, write 1 to clear 0: No Pending Interrupt 1: Plug in Irq Pending Interrupt
18	R/W	0x0	HMIC_KEYUP_PENDING Hmic Key Up Irq pending bit, write 1 to clear 0: No Pending Interrupt 1: Key up Irq Pending Interrupt
17	R/W	0x0	HMIC_KEYDOWN_PENDING Hmic Key Down Irq pending bit, write 1 to clear 0: No Pending Interrupt 1: Key down Irq Pending Interrupt
16	R/W	0x0	HMIC_DATA_PENDING Hmic Data Irq pending bit, write 1 to clear 0: No Pending Interrupt 1: Data Irq Pending Interrupt
15:5	/	/	/
4:0	R	0x0	HMIC_DATA HMIC ADC Data

**4.13.5.14. 0x060 DAC DAP Control Register(Default Value: 0x00000000)**

Offset: 0x060			Register Name: <b>AC_DAC_DAP_CTR</b>
Bit	R/W	Default/Hex	Description
31	R/W	0X0	DDAP_EN DAP for dac Enable 0 : bypass 1 : enable
30:16	/	/	/
15	R/W	0X0	DDAP_DRC_EN DRC enable control

			0:disable 1:enable
14	R/W	0X0	DDAP_HPF_EN HPF enable control 0:disable 1:enable
13:0	/	/	/

**4.13.5.15. 0x070 ADC DAP Control Register(Default Value: 0x00000000)**

Offset: 0x070			Register Name: <b>AC_ADC_DAP_CTR</b>
Bit	R/W	Default/Hex	Description
31	R/W	0X0	ADAP_EN DAP for ADC enable 0 : bypass 1: enable
30	R/W	0x0	ADAP_START. DAP for ADC start up 0 : disable 1: start up
29:27	/	/	/
26	R/W	0x0	ENADC_DRC DRC for ADC enable 0 : bypass 1 : enable
25	R/W	0x0	ADC_DRC_EN ADC DRC function enable 0 : disable 1 : enable
24	R/W	0x0	ADC_DRC_HPF_EN ADC DRC HPF function enable 0 : disable 1 : enable
23:22	/	/	/
21	R	0x0	ADAP_LSATU_FLAG. Left channel AGC saturation flag 0 : no saturation 1: saturation
20	R	0x0	ADAP_LNOI_FLAG. Left channel AGC noise-threshold flag
19:12	R	0x0	ADAP_LCHAN_GAIN Left channel Gain applied by AGC (7.1format 2s component(-20dB - 40dB), 0.5dB/ step) 0x50 : 40dB

			0x4F : 39.5dB ----- 0x00 : 00dB 0xFF : -0.5dB
11:10	/	/	/
9	R	0x0	ADAP_RSATU_FLAG. Right AGC saturation flag 0 : no saturation 1: saturation
8	R	0x0	ADAP_RNOI_FLAG. Right channel AGC noise-threshold flag
7:0	R	0x0	ADAP_LCHAN_GAIN. Right Channel Gain applied by AGC (7.1format 2s component)(0.5dB step) 0x50 : 40dB 0x4F : 39.5dB ----- 0x00 : 00dB 0xFF : -0.5dB

**4.13.5.16. 0x074 ADC DAP Left Control Register(Default Value: 0x001F1800)**

Offset: 0x074			Register Name: AC_ADC_DAP_LCTR
Bit	R/W	Default/Hex	Description
31:24	/	/	/
23:16	R/W	0x1F  (-86dB)	ADAP_LNOI_SET. Left channel noise threshold setting 0x00 : -24dB 0x01 : -26dB 0x02 : -28dB ----- 0x1D: -82dB 0x1E: -84dB 0x1F: -86dB
15	/	/	/
14	R/W	0x1	AAGC_LCHAN_EN. Left AGC function enable 0:disable 1: enable
13	R/W	0x1	ADAP_LHPF_EN. Left HPF enable 0: disable 1: enable
12	R/W	0x1	ADAP_LNOI_DET. Left Noise detect enable

			0: disable 1: enable
11:10	/	/	/
9:8	R/W	0x0	ADAP_LCHAN_HYS. Left Hysteresis setting 00 : 1dB 01 : 2dB 10 : 4dB 11 : disable
7:4	R/W	0x0	ADAP_LNOI_DEB. Left Noise debounce time 0000:0/fs 0001:4/fs 0010:8/fs ----- 1111 :16*4096/fs T=2(N+1)/fs ,except N=0
3:0	R/W	0x0	ADAP_LSIG_DEB. Left Signal debounce time 0000:0/fs 0001:4/fs 0010:8/fs ----- 1111 :16*4096/fs T=2(N+1)/fs ,except N=0

**4.13.5.17. 0x078 ADC DAP Right Control Register(Default Value: 0x001F7000)**

Offset: 0x078			Register Name: AC_ADC_DAP_RCTR
Bit	R/W	Default/Hex	Description
31:21	/	/	/
20:16	R/W	0x1F (-86dB)	ADAP_RNOI_SET. Right channel noise threshold setting 0x00 : -24dB 0x01 : -26dB 0x02 : -28dB ----- 0x1D: -82dB 0x1E: -84dB 0x1F: -86dB
15	/	/	/
14	R/W	0x1	AAGC_RCHAN_EN. Right AGC enable 0:disable

			1:enable
13	R/W	0x1	ADAP_RHPF_EN. Right HPF enable 0: disable 1: enable
12	R/W	0x1	ADAP_RNOI_DET. Right Noise detect enable 0: disable 1:enable
11:10	/	/	/
9:8	R/W	0x0	ADAP_RCHAN_HYS. Right Hysteresis setting 00 : 1dB 01 : 2dB 10 : 4dB 11 : disable;
7:4	R/W	0x0	ADAP_RNOI_DEB. Right Noise debounce time 0000:0/fs 0001:4/fs 0010:8/fs ----- 1111: 16*4096/fs T=2(N+1)/fs ,except N=0
3:0	R/W	0x0	ADAP_RSIG_DEB. Right Signal debounce time 0000:0/fs 0001:4/fs 0010:8/fs ----- 1111: 16*4096/fs T=2(N+1)/fs ,except N=0

**4.13.5.18. 0x07CAD C DAP Parameter Register(Default Value: 0x2C2C2828)**

Offset: 0x07C			Register Name: <b>AC_ADC_DAP_PARA</b>
Bit	R/W	Default/Hex	Description
31:30	/	/	/
29:24	R/W	0x2C	ADAP_LTARG_SET. Left channel target level setting (-1dB -- -30dB). (6.0format 2s component)
23:22	/	/	/
21:16	R/W	0x2C	ADAP_RTARG_SET. Right channel target level setting (-1dB -- -30dB). (6.0format 2s component)
15:8	R/W	0x28	ADAP_LGAIN_MAX.

			Left channel max gain setting (0-40dB). (7.1format 2s component)
7:0	R/W	0x28	ADAP_RGAIN_MAX. Right channel max gain setting (0-40dB). (7.1format 2s component)

**4.13.5.19. 0x080 ADC DAP Left Average Coef Register(Default Value: 0x00051EB8)**

Offset: 0x080			Register Name: <b>AC_ADC_DAP_LAC</b>
Bit	R/W	Default/Hex	Description
31:27	/	/	/
26:0	R/W	0x0051EB8	ADAP_LAC. Average level coefficient setting(3.24format 2s component)

**4.13.5.20. 0x084 ADC DAP Left Decay & Attack Time Register(Default Value: 0x0000001F)**

Offset: 0x084			Register Name: <b>AC_ADC_DAP_LDAT</b>
Bit	R/W	Default/Hex	Description
31	/	/	/
30:16	R/W	0x0000	ADAP_LATT_SET Left attack time coefficient setting 0000 : 1x32/fs 0001 : 2x32/fs ----- 7FFF : 215 x32/fs $T=(n+1)*32*fs$ When the gain decreases, the actual gain will decrease 0.5dB at every attack time.
15	/	/	/
14:0	R/W	0x001F  (32x32fs)	ADAP_LDEC_SET Left decay time coefficient setting 0000 : 1x32/fs 0001 : 2x32/fs ----- 7FFF : 215 x32/fs $T=(n+1)*32/fs$ When the gain increases, the actual gain will increase 0.5dB at every decay time.

**4.13.5.21. 0x088 ADC DAP Right Average Coef Register(Default Value: 0x00051EB8)**

Offset: 0x088			Register Name: <b>AC_ADC_DAP_RAC</b>
Bit	R/W	Default/Hex	Description
31:27	/	/	/

26:0	R/W	0x0051EB8	ADAP_RAC. Average level coefficient setting(3.24format)
------	-----	-----------	--

**4.13.5.22. 0x08C ADC DAP Right Decay & Attack Time Register(Default Value: 0x0000001F)**

Offset: 0x8C			Register Name: AC_ADC_DAP_RDAT
Bit	R/W	Default/Hex	Description
31	/	/	/
30:16	R/W	0x0000	ADAP_RATT_SET. Right attack time coefficient setting 0000 : 1x32/fs 0001 : 2x32/fs ----- 7FFF : 215 x32/fs $T=(n+1)*32/fs$ When the gain decreases, the actual gain will decrease 0.5dB at every attack time.
15	/	/	/
14:0	R/W	0x001F	ADAP_RDEC_SET Right decay time coefficient setting 0000 : 1x32/fs 0001 : 2x32/fs ----- 7FFF : 215x32/fs $T=(n+1)*32/fs$ When the gain increases, the actual gain will increase 0.5dB at every decay time.

**4.13.5.23. 0x090 ADC DAP HPF Coef Register(Default Value: 0x00FFAC1)**

Offset: 0x090			Register Name: AC_ADC_DAP_HPFC
Bit	R/W	Default/Hex	Description
31:27	/	/	/
26:0	R/W	0x0FFAC1	ADAP_HPFC. HPF coefficient setting (3.24format)

**4.13.5.24. 0x094 ADC DAP Left Input Signal Low Average Coef Register(Default Value: 0x00051EB8)**

Offset: 0x094			Register Name: AC_ADC_DAP_LINAC
Bit	R/W	Default/Hex	Description
31:27	/	/	/

26:0	R/W	0x0051EB8	ADAP_LINAC Left input signal average filter coefficient to check noise or not (the coefficient is 3.24 format 2s complement) always the same as the left output signal average filter's
------	-----	-----------	--

**4.13.5.25. 0x098 ADC DAP Right Input Signal Low Average Coef Register(Default Value: 0x00051EB8)**

Offset: 0x098			Register Name: <b>AC_ADC_DAP_RNAC</b>
Bit	R/W	Default/Hex	Description
31:27	/	/	/
26:0	R/W	0x0051EB8	ADAP_RINAC Right input signal average filter coefficient to check noise or not (the coefficient is 3.24 format 2s complement) always the same as the left output signal average filter's

**4.13.5.26. 0x09C ADC DAP Optimum Register(Default Value: 0x00000000)**

Offset: 0x09C			Register Name: <b>AC_ADC_DAP_OPT</b>
Bit	R/W	Default/Hex	Description
31:11	/	/	/
10	R/W	0x0	Left energy default value setting(include the input and output) 0 : min 1 : max
9 :8	R/W	0x0	Left channel gain hysteresis setting. The different between target level and the signal level must larger than the hysteresis when the gain change. 00 : 0.4375db 01 : 0.9375db 10 : 1.9375db 11 : 3db
7:3	/	/	/
5	R/W	0x0	The input signal average filter coefficient setting 0 : is the reg94/reg98 1 : is the reg80/reg88;
4	R/W	0x0	AGC output when the channel in noise state 0 : output is zero 1 : output is the input data
3	/	/	/
2	R/W	0x0	Right energy default value setting(include the input and output) 0 : min 1 : max
1 :0	R/W	0x0	Right channel gain hysteresis setting.



			<p>The different between target level and the signal level must larger than the hysteresis when the gain change.</p> <p>00 : 0.4375db          01 : 0.9375db          10 : 1.9375db          11 : 3db</p>
--	--	--	---

**4.13.5.27. 0x100 DAC DRC High HPF Coef Register(Default Value: 0x000000FF)**

Offset: 0x100			Register Name: <b>AC_DAC_DRC_HHPFC</b>
Bit	R/W	Default/Hex	Description
15:11	/	/	/
10:0	R/W	0xFF	HPF coefficient setting and the data is 3.24 format.

**4.13.5.28. 0x104 DAC DRC Low HPF Coef Register(Default Value: 0x0000FAC1)**

Offset: 0x104			Register Name: <b>AC_DAC_DRC_LHPFC</b>
Bit	R/W	Default/Hex	Description
15:0	R/W	0xFAC1	HPF coefficient setting and the data is 3.24 format.

**4.13.5.29. 0x108 DAC DRC Control Register(Default Value: 0x00000080)**

Offset: 0x108			Register Name: <b>AC_DAC_DRC_CTRL</b>
Bit	R/W	Default/Hex	Description
15	R	0	<p>DRC delay buffer data output state when drc delay function is enable and the drc function disable. After disable drc function and this bit go to 0, the user should write the drc delay function bit to 0;</p> <p>0 : not complete          1 : is complete</p>
14:10	/	/	/
13:8	R/W	0	<p>Signal delay time setting</p> <p>6'h00 : (8x1)fs          6'h01 : (8x2)fs          6'h02 : (8x3)fs          -----          6'h2e : (8*47)fs          6'h2f : (8*48)fs          6'h30 -- 6'h3f : (8*48)fs          Delay time = 8*(n+1)fs, n&lt;6'h30;          When the delay function is disable, the signal delay time is unused.</p>
7	R/W	0x1	The delay buffer use or not when the drc disable and the drc buffer data

			output completely 0 : don't use the buffer 1 : use the buffer
6	R/W	0x0	DRC gain max limit enable 0 : disable 1 : enable
5	R/W	0x0	DRC gain min limit enable. when this fuction enable, it will overwrite the noise detect fuction. 0 : disable 1 : enable
4	R/W	0x0	Control the drc to detect noise when ET enable 0 : disable 1 : enable
3	R/W	0x0	Signal function Select 0 : RMS filter 1 : Peak filter When Signal function Select Peak filter, the RMS parameter is unused. (AC_DRC_LRMSHAT / AC_DRC_LRMSLAT / AC_DRC_LRMSHAT / AC_DRC_LRMSLAT) When Signal function Select RMS filter, the Peak filter parameter is unused.(AC_DRC_LPFHAT / AC_DRC_LPFLAT / AC_DRC_RPFHAT / AC_DRC_RPFLAT / AC_DRC_LPFHRT / AC_DRC_LPFLRT / AC_DRC_RPFHRT / AC_DRC_RPFLRT)
2	R/W	0x0	Delay function enable 0 : disable 1 : enable When the Delay function enable is disable, the Signal delay time is unused.
1	R/W	0x0	DRC LT enable 0 : disable 1 : enable When the DRC LT is disable the LT, KI and OPL parameter is unused.
0	R/W	0x0	DRC ET enable 0 : disable 1 : enable When the DRC ET is disable the ET, Ke and OPE parameter is unused.

#### 4.13.5.30. 0x10C DAC DRC Left Peak Filter High Attack Time Coef Register(Default Value: 0x0000000B)

Offset: 0x10C			Register Name: <b>AC_DAC_DRC_LPFHAT</b>
Bit	R/W	Default/Hex	Description
15:11	/	/	/
10:0	R/W	0x000B	The left peak filter attack time parameter setting, which determine by the equation that $AT = 1 - \exp(-2.2T_s/ta)$ . The format is 3.24. (1ms)

**4.13.5.31. 0x110 DAC DRC Left Peak Filter Low Attack Time Coef Register(Default Value: 0x000077BF)**

Offset: 0x110			Register Name: <b>AC_DAC_DRC_LPFLAT</b>
Bit	R/W	Default/Hex	Description
15:0	R/W	0x77BF	The left peak filter attack time parameter setting, which determine by the equation that $AT = 1 - \exp(-2.2T_s/ta)$ . The format is 3.24. (1ms)

**4.13.5.32. 0x114 DAC DRC Right Peak Filter High Attack Time Coef Register(Default Value: 0x0000000B)**

Offset: 0x114			Register Name: <b>AC_DAC_DRC_RPFHAT</b>
Bit	R/W	Default/Hex	Description
15:11	/	/	/
10:0	R/W	0x000B	The left peak filter attack time parameter setting, which determine by the equation that $AT = 1 - \exp(-2.2T_s/ta)$ . The format is 3.24. (1ms)

**4.13.5.33. 0x118 DAC DRC Peak Filter Low Attack Time Coef Register(Default Value: 0x000077BF)**

Offset: 0x118			Register Name: <b>AC_DAC_DRC_RPFLAT</b>
Bit	R/W	Default/Hex	Description
15:0	R/W	0x77BF	The left peak filter attack time parameter setting, which determine by the equation that $AT = 1 - \exp(-2.2T_s/ta)$ . The format is 3.24. (1ms)

**4.13.5.34. 0x11C DAC DRC Left Peak Filter High Release Time Coef Register(Default Value: 0x000000FF)**

Offset: 0x11C			Register Name: <b>AC_DAC_DRC_LPFHRT</b>
Bit	R/W	Default/Hex	Description
15:11	/	/	/
10:0	R/W	0x00FF	The left peak filter release time parameter setting, which determine by the equation that $RT = \exp(-2.2T_s/tr)$ . The format is 3.24. (100ms)

**4.13.5.35. 0x120 DAC DRC Left Peak Filter Low Release Time Coef Register(Default Value: 0x0000E1F8)**

Offset: 0x120			Register Name: <b>AC_DAC_DRC_LPFLRT</b>
Bit	R/W	Default/Hex	Description
15:0	R/W	0xE1F8	The left peak filter release time parameter setting, which determine by the equation that $RT = \exp(-2.2T_s/tr)$ . The format is 3.24. (100ms)

**4.13.5.36. 0x124 DAC DRC Right Peak filter High Release Time Coef Register(Default Value: 0x000000FF)**

Offset: 0x124			Register Name: <b>AC_DAC_DRC_RPFHRT</b>
Bit	R/W	Default/Hex	Description
15:11	/	/	/
10:0	R/W	0x00FF	The left peak filter attack time parameter setting, which determine by the equation that $RT = \exp(-2.2Ts/tr)$ . The format is 3.24. (100ms)

**4.13.5.37. 0x128 DAC DRC Right Peak filter Low Release Time Coef Register(Default Value: 0x0000E1F8)**

Offset: 0x128			Register Name: <b>AC_DAC_DRC_RPFLRT</b>
Bit	R/W	Default/Hex	Description
15:0	R/W	0xE1F8	The left peak filter release time parameter setting, which determine by the equation that $AT = \exp(-2.2Ts/tr)$ . The format is 3.24. (100ms)

**4.13.5.38. 0x12C DAC DRC Left RMS Filter High Coef Register(Default Value: 0x00000001)**

Offset: 0x12C			Register Name: <b>AC_DAC_DRC_LRMSHAT</b>
Bit	R/W	Default/Hex	Description
15:11	/	/	/
10:0	R/W	0x0001	The left RMS filter average time parameter setting, which determine by the equation that $AT = 1-\exp(-2.2Ts/tav)$ . The format is 3.24. (10ms)

**4.13.5.39. 0x130 DAC DRC Left RMS Filter Low Coef Register(Default Value: 0x00002BAF)**

Offset: 0x130			Register Name: <b>AC_DAC_DRC_LRMSLAT</b>
Bit	R/W	Default/Hex	Description
15:0	R/W	0x2BAF	The left RMS filter average time parameter setting, which determine by the equation that $AT = 1-\exp(-2.2Ts/tav)$ . The format is 3.24. (10ms)

**4.13.5.40. 0x134 DAC DRC Right RMS Filter High Coef Register(Default Value: 0x00000001)**

Offset: 0x134			Register Name: <b>AC_DAC_DRC_RRMSHAT</b>
Bit	R/W	Default/Hex	Description
15:11	/	/	/
10:0	R/W	0x0001	The right RMS filter average time parameter setting, which determine by the equation that $AT = 1-\exp(-2.2Ts/tav)$ . The format is 3.24. (10ms)

**4.13.5.41. 0x138 DAC DRC Right RMS Filter Low Coef Register(Default Value: 0x00002BAF)**

Offset: 0x138			Register Name: <b>AC_DAC_DRC_RRMSLAT</b>
Bit	R/W	Default/Hex	Description
15:0	R/W	0x2BAF	The right RMS filter average time parameter setting, which determine by the equation that $AT = 1 - \exp(-2.2Ts/tav)$ . The format is 3.24. (10ms)

**4.13.5.42. 0x13C DAC DRC Compressor Theshold High Setting Register(Default Value: 0x000006A4)**

Offset: 0x13C			Register Name: <b>AC_DAC_DRC_HCT</b>
Bit	R/W	Default/Hex	Description
15:0	R/W	0x06A4	The compressor threshold setting, which set by the equation that $CTin = -CT/6.0206$ . The format is 8.24 (-40dB)

**4.13.5.43. 0x140 DAC DRC Compressor Slope High Setting Register(Default Value: 0x0000D3C0)**

Offset: 0x140			Register Name: <b>AC_DAC_DRC_LCT</b>
Bit	R/W	Default/Hex	Description
15:0	R/W	0xD3C0	The compressor threshold setting, which set by the equation that $CTin = -CT/6.0206$ . The format is 8.24 (-40dB)

**4.13.5.44. 0x144 DAC DRC Compressor Slope High Setting Register(Default Value: 0x00000080)**

Offset: 0x144			Register Name: <b>AC_DAC_DRC_HKC</b>
Bit	R/W	Default/Hex	Description
15:13	/	/	/
13:0	R/W	0x0080	The slope of the compressor which determine by the equation that $Kc = 1/R$ , there, R is the ratio of the compressor, which always is interger. The format is 8.24. (2 : 1)

**4.13.5.45. 0x148 DAC DRC Compressor Slope Low Setting Register(Default Value: 0x00000000)**

Offset: 0x148			Register Name: <b>AC_DAC_DRC_LKC</b>
Bit	R/W	Default/Hex	Description
15:0	R/W	0x0000	The slope of the compressor which determine by the equation that $Kc = 1/R$ , there, R is the ratio of the compressor, which always is interger. The format is 8.24. (2 : 1)

**4.13.5.46. 0x14C DAC DRC Compressor High Output at Compressor Threshold Register(Default Value: 0x0000F95B)**

Offset: 0x14C			Register Name: <b>AC_DAC_DRC_HOPC</b>
Bit	R/W	Default/Hex	Description
15:0	R/W	0xF95B	The output of the compressor which determine by the equation $-OPC/6.0206$ The format is 8.24 (-40dB)

**4.13.5.47. 0x150 DAC DRC Compressor Low Output at Compressor Threshold Register(Default Value: 0x00002C3F)**

Offset: 0x150			Register Name: <b>AC_DAC_DRC_LOPC</b>
Bit	R/W	Default/Hex	Description
15:0	R/W	0x2C3F	The output of the compressor which determine by the equation $OPC/6.0206$ The format is 8.24 (-40dB)

**4.13.5.48. 0x154 DAC DRC Limiter Theshold High Setting Register(Default Value: 0x000001A9)**

Offset: 0x154			Register Name: <b>AC_DAC_DRC_HLT</b>
Bit	R/W	Default/Hex	Description
15:0	R/W	0x01A9	The limiter threshold setting, which set by the equation that $LT_{in} = -LT/6.0206$ , The format is 8.24. (-10dB)

**4.13.5.49. 0x158 DAC DRC Limiter Theshold Low Setting Register(Default Value: 0x000034F0)**

Offset: 0x158			Register Name: <b>AC_DAC_DRC_LLT</b>
Bit	R/W	Default/Hex	Description
15:0	R/W	0x34F0	The limiter threshold setting, which set by the equation that $LT_{in} = -LT/6.0206$ , The format is 8.24. (-10dB)

**4.13.5.50. 0x15C DAC DRC Limiter Slope High Setting Register(Default Value: 0x00000005)**

Offset: 0x15C			Register Name: <b>AC_DAC_DRC_HKI</b>
Bit	R/W	Default/Hex	Description
15:11	/	/	/
13:0	R/W	0x0005	The slope of the limiter which determine by the equation that $KI = 1/R$ , there, R is the ratio of the limiter, which always is interger. The format is 8.24. (50 :1)

**4.13.5.51. 0x160 DAC DRC Limiter Slope Low Setting Register(Default Value: 0x1EB8)**

Offset: 0x160			Register Name: <b>AC_DAC_DRC_LKI</b>
Bit	R/W	Default/Hex	Description
15:0	R/W	0x1EB8	The slope of the limiter which determine by the equation that $KI = 1/R$ , there, R is the ratio of the limiter, which always is interger. The format is 8.24. (50 :1)

**4.13.5.52. 0x164 DAC DRC Limiter High Output at Limiter Threshold(Default Value: 0x0000FBD8)**

Offset: 0x164			Register Name: <b>AC_DAC_DRC_HOPL</b>
Bit	R/W	Default/Hex	Description
15:0	R/W	0xFBD8	The output of the limiter which determine by equation $OPT/6.0206$ . The format is 8.24 (-25dB)

**4.13.5.53. 0x168 DAC DRC Limiter Low Output at Limiter Threshold(Default Value: 0x0000FBA7)**

Offset: 0x168			Register Name: <b>AC_DAC_DRC_LOPL</b>
Bit	R/W	Default/Hex	Description
15:0	R/W	0xFBA7	The output of the limiter which determine by equation $OPT/6.0206$ . The format is 8.24 (-25dB)

**4.13.5.54. 0x16C DAC DRC Expander Theshold High Setting Register(Default Value: 0x00000BA0)**

Offset: 0x16C			Register Name: <b>AC_DAC_DRC_HET</b>
Bit	R/W	Default/Hex	Description
15:0	R/W	0x0BA0	The expander threshold setting, which set by the equation that $ET_{in} = -ET/6.0206$ , The format is 8.24. (-70dB)

**4.13.5.55. 0x170 DAC DRC Expander Theshold Low Setting Register(Default Value: 0x00007291)**

Offset: 0x170			Register Name: <b>AC_DAC_DRC_LET</b>
Bit	R/W	Default/Hex	Description
15:0	R/W	0x7291	The expander threshold setting, which set by the equation that $ET_{in} = -ET/6.0206$ , The format is 8.24. (-70dB)

**4.13.5.56. 0x174 DAC DRC Expander Slope High Setting Register(Default Value: 0x00000500)**

Offset: 0x174			Register Name: <b>AC_DAC_DRC_HKE</b>
---------------	--	--	--------------------------------------

Bit	R/W	Default/Hex	Description
15:14	/	/	/
13:0	R/W	0x0500	The slope of the expander which determine by the equation that $K_e = 1/R$ , there, R is the ratio of the expander, which always is interger and the ke must larger than 50. The format is 8.24. (1:5)

**4.13.5.57. 0x178 DAC DRC Expander Slope Low Setting Register(Default Value: 0x00000000)**

Offset: 0x178			Register Name: AC_DAC_DRC_LKE
Bit	R/W	Default/Hex	Description
15:0	R/W	0x0000	The slope of the expander which determine by the equation that $K_e = 1/R$ , there, R is the ratio of the expander, which always is interger and the ke must larger than 50. The format is 8.24. (1:5)

**4.13.5.58. 0x17C DAC DRC Expander High Output at Expander Threshold(Default Value: 0xF45F)**

Offset: 0x17C			Register Name: AC_DAC_DRC_HOPE
Bit	R/W	Default/Hex	Description
15:0	R/W	0xF45F	The output of the expander which determine by equation $OPE/6.0206$ . The format is 8.24 (-70dB)

**4.13.5.59. 0x180 DAC DRC Expander Low Output at Expander Threshold(Default Value: 0x00008D6E)**

Offset: 0x180			Register Name: AC_DAC_DRC_LOPE
Bit	R/W	Default/Hex	Description
15:0	R/W	0x8D6E	The output of the expander which determine by equation $OPE/6.0206$ . The format is 8.24 (-70dB)

**4.13.5.60. 0x184 DAC DRC Linear Slope High Setting Register(Default Value: 0x00000100)**

Offset: 0x184			Register Name: AC_DAC_DRC_HKN
Bit	R/W	Default/Hex	Description
15:14	/	/	/
13:0	R/W	0x0100	The slope of the linear which determine by the equation that $K_n = 1/R$ , there, R is the ratio of the linear, which always is interger . The format is 8.24. (1:1)



**4.13.5.61. 0x188 DAC DRC Linear Slope Low Setting Register(Default Value: 0x00000000)**

Offset: 0x188			Register Name: <b>AC_DAC_DRC_LKN</b>
Bit	R/W	Default/Hex	Description
15:0	R/W	0x0000	The slope of the linear which determine by the equation that $K_n = 1/R$ , there, R is the ratio of the linear, which always is interger . The format is 8.24. (1:1)

**4.13.5.62. 0x18C DAC DRC Smooth filter Gain High Attack Time Coef Register(Default Value: 0x00000002)**

Offset: 0x18C			Register Name: <b>AC_DAC_DRC_SFHAT</b>
Bit	R/W	Default/Hex	Description
15:11	/	/	/
10:0	R/W	0x0002	The smooth filter attack time parameter setting, which determine by the equation that $AT = 1 - \exp(-2.2T_s/tr)$ . The format is 3.24. (5ms)

**4.13.5.63. 0x190 DAC DRC Smooth filter Gain Low Attack Time Coef Register(Default Value: 0x00005600)**

Offset: 0x190			Register Name: <b>AC_DAC_DRC_SFLAT</b>
Bit	R/W	Default/Hex	Description
15:0	R/W	0x5600	The smooth filter attack time parameter setting, which determine by the equation that $AT = 1 - \exp(-2.2T_s/tr)$ . The format is 3.24. (5ms)

**4.13.5.64. 0x194 DAC DRC Smooth filter Gain High Release Time Coef Register(Default Value: 0x00000000)**

Offset: 0x194			Register Name: <b>AC_DAC_DRC_SFHRT</b>
Bit	R/W	Default/Hex	Description
15:11	/	/	/
10:0	R/W	0x0000	The gain smooth filter release time parameter setting, which determine by the equation that $RT = 1 - \exp(-2.2T_s/tr)$ . The format is 3.24. (200ms)

**4.13.5.65. 0x198 DAC DRC Smooth filter Gain Low Release Time Coef Register(Default Value: 0x00000F04)**

Offset: 0x198			Register Name: <b>AC_DAC_DRC_SFLRT</b>
Bit	R/W	Default/Hex	Description
15:0	R/W	0x0F04	The gain smooth filter release time parameter setting, which determine by the equation that $RT = 1 - \exp(-2.2T_s/tr)$ . The format is 3.24. (200ms)

**4.13.5.66. 0x19C DAC DRC MAX Gain High Setting Register(Default Value: 0x0000FE56)**

Offset: 0x19C			Register Name: <b>AC_DAC_DRC_MXGHS</b>
Bit	R/W	Default/Hex	Description
15:0	R/W	0xFE56	The max gain setting which determine by equation MXG/6.0206. The format is 8.24 and must $-20\text{dB} < \text{MXG} < 30\text{dB}$ (-10dB)

**4.13.5.67. 0x1A0 DAC DRC MAX Gain Low Setting Register(Default Value: 0x0000CB0F)**

Offset: 0x1A0			Register Name: <b>AC_DAC_DRC_MXGLS</b>
Bit	R/W	Default/Hex	Description
15:0	R/W	0xCB0F	The max gain setting which determine by equation MXG/6.0206. The format is 8.24 and must $-20\text{dB} < \text{MXG} < 30\text{dB}$ (-10dB)

**4.13.5.68. 0x1A4 DAC DRC MIN Gain High Setting Register(Default Value: 0x0000\_F95B)**

Offset: 0x1A4			Register Name: <b>AC_DAC_DRC_MNGHS</b>
Bit	R/W	Default/Hex	Description
15:0	R/W	0xF95B	The min gain setting which determine by equation MXG/6.0206. The format is 8.24 and must $-60\text{dB} \leq \text{MNG} \leq -30\text{dB}$ (-40dB)

**4.13.5.69. 0x1A8 DAC DRC MIN Gain Low Setting Register(Default Value: 0x00002C3F)**

Offset: 0x1A8			Register Name: <b>AC_DAC_DRC_MNGLS</b>
Bit	R/W	Default/Hex	Description
15:0	R/W	0x2C3F	The min gain setting which determine by equation MNG/6.0206. The format is 8.24 and must $-60\text{dB} \leq \text{MNG} \leq -30\text{dB}$ (-40dB)

**4.13.5.70. 0x1AC DAC DRC Expander Smooth Time High Coef Register(Default Value: 0x00000000)**

Offset: 0x1AC			Register Name: <b>AC_DAC_DRC_EPSHC</b>
Bit	R/W	Default/Hex	Description
11:0	R/W	0x0000	The gain smooth filter release and attack time parameter setting in expander region, which determine by the equation that $RT = 1 - \exp(-2.2T_s/tr)$ . The format is 3.24. (30ms)

**4.13.5.71. 0x1B0 DAC DRC Expander Smooth Time Low Coef Register(Default Value: 0x0000640C)**

Offset: 0x1B0			Register Name: <b>AC_DAC_DRC_EPSLC</b>
Bit	R/W	Default/Hex	Description
15:0	R/W	0x640C	The gain smooth filter release and attack time parameter setting in expander region, which determine by the equation that $RT = 1 - \exp(-2.2Ts/tr)$ . The format is 3.24. (30ms)

**4.13.5.72. 0x1B8 DAC DRC HPF Gain High Coef Register(Default Value: 0x00000100)**

Offset: 0x1B8			Register Name: <b>AC_DAC_DRC_HPFHGAIN</b>
Bit	R/W	Default/Hex	Description
15:11	/	/	/
10:0	R/W	0X100	The gain of the hpf coefficient setting which format is 3.24.(gain = 1)

**4.13.5.73. 0x1BC DAC DRC HPF Gain Low Coef Register(Default Value: 0x00000000)**

Offset: 0x1BC			Register Name: <b>AC_DAC_DRC_HPFLGAIN</b>
Bit	R/W	Default/Hex	Description
15:0	R/W	0X0000	The gain of the hpf coefficient setting which format is 3.24.(gain = 1)

**4.13.5.74. 0x200 ADC DRC High HPF Coef Register(Default Value: 0x000000FF)**

Offset: 0x200			Register Name: <b>AC_ADC_DRC_HHPFC</b>
Bit	R/W	Default/Hex	Description
15:11	/	/	/
10:0	R/W	0xFF	HPF coefficient setting and the data is 3.24 format.

**4.13.5.75. 0x204 ADC DRC Low HPF Coef Register(Default Value: 0x0000FAC1)**

Offset: 0x204			Register Name: <b>AC_ADC_DRC_LHPFC</b>
Bit	R/W	Default/Hex	Description
15:0	R/W	0xFAC1	HPF coefficient setting and the data is 3.24 format.

**4.13.5.76. 0x208 ADC DRC Control Register(Default Value: 0x00000080)**

Offset: 0x208			Register Name: <b>AC_ADC_DRC_CTRL</b>
Bit	R/W	Default/Hex	Description

15	R	0	DRC delay buffer data output state when drc delay function is enable and the drc function disable. After disable drc function and this bit go to 0, the user should write the drc delay function bit to 0; 0 : not complete 1 : is complete
14:10	/	/	/
13:8	R/W	0	Signal delay time setting 6'h00 : (8x1)fs 6'h01 : (8x2)fs 6'h02 : (8x3)fs ----- 6'h2e : (8*47)fs 6'h2f : (8*48)fs 6'h30 -- 6'h3f : (8*48)fs Delay time = 8*(n+1)fs, n<6'h30; When the delay function is disable, the signal delay time is unused.
7	R/W	0x1	The delay buffer use or not when the drc disable and the drc buffer data output completely 0 : don't use the buffer 1 : use the buffer
6	R/W	0x0	DRC gain max limit enable 0 : disable 1 : enable
5	R/W	0x0	DRC gain min limit enable. when this function enable, it will overwrite the noise detect function. 0 : disable 1 : enable
4	R/W	0x0	Control the drc to detect noise when ET enable 0 : disable 1 : enable
3	R/W	0x0	Signal function Select 0 : RMS filter 1 : Peak filter When Signal function Select Peak filter, the RMS parameter is unused. (AC_DRC_LRMSHAT / AC_DRC_LRMSLAT / AC_DRC_LRMSHAT / AC_DRC_LRMSLAT)  When Signal function Select RMS filter, the Peak filter parameter is unused.(AC_DRC_LPFHAT / AC_DRC_LPFLAT / AC_DRC_RPFHAT / AC_DRC_RPFLAT / AC_DRC_LPFHRT / AC_DRC_LPFLRT / AC_DRC_RPFHRT / AC_DRC_RPFLRT)
2	R/W	0x0	Delay function enable 0 : disable 1 : enable When the Delay function enable is disable, the Signal delay time is unused.

1	R/W	0x0	DRC LT enable 0 : disable 1 : enable When the DRC LT is disable the LT, KI and OPL parameter is unused.
0	R/W	0x0	DRC ET enable 0 : disable 1 : enable When the DRC ET is disable the ET, Ke and OPE parameter is unused.

**4.13.5.77. 0x20C ADC DRC Left Peak Filter High Attack Time Coef Register(Default Value: 0x0000000B)**

Offset: 0x20C			Register Name: <b>AC_ADC_DRC_LPFHAT</b>
Bit	R/W	Default/Hex	Description
15:11	/	/	/
10:0	R/W	0x000B	The left peak filter attack time parameter setting, which determine by the equation that $AT = 1 - \exp(-2.2T_s/ta)$ . The format is 3.24. (1ms)

**4.13.5.78. 0x210 ADC DRC Left Peak Filter Low Attack Time Coef Register(Default Value: 0x000077BF)**

Offset: 0x210			Register Name: <b>AC_ADC_DRC_LPFLAT</b>
Bit	R/W	Default/Hex	Description
15:0	R/W	0x77BF	The left peak filter attack time parameter setting, which determine by the equation that $AT = 1 - \exp(-2.2T_s/ta)$ . The format is 3.24. (1ms)

**4.13.5.79. 0x214 ADC DRC Right Peak Filter High Attack Time Coef Register(Default Value: 0x0000000B)**

Offset: 0x214			Register Name: <b>AC_ADC_DRC_RPFHAT</b>
Bit	R/W	Default/Hex	Description
15:11	/	/	/
10:0	R/W	0x000B	The left peak filter attack time parameter setting, which determine by the equation that $AT = 1 - \exp(-2.2T_s/ta)$ . The format is 3.24. (1ms)

**4.13.5.80. 0x218 ADC DRC Peak Filter Low Attack Time Coef Register(Default Value: 0x000077BF)**

Offset: 0x218			Register Name: <b>AC_ADC_DRC_RPFLAT</b>
Bit	R/W	Default/Hex	Description
15:0	R/W	0x77BF	The left peak filter attack time parameter setting, which determine by the equation that $AT = 1 - \exp(-2.2T_s/ta)$ . The format is 3.24. (1ms)

**4.13.5.81. 0x21C ADC DRC Left Peak Filter High Release Time Coef Register(Default Value: 0x000000FF)**

Offset: 0x21C			Register Name: <b>AC_ADC_DRC_LPFHRT</b>
Bit	R/W	Default/Hex	Description
15:11	/	/	/
10:0	R/W	0x00FF	The left peak filter release time parameter setting, which determine by the equation that $RT = \exp(-2.2Ts/tr)$ . The format is 3.24. (100ms)

**4.13.5.82. 0x220 ADC DRC Left Peak Filter Low Release Time Coef Register(Default Value: 0x0000E1F8)**

Offset: 0x220			Register Name: <b>AC_ADC_DRC_LPFLRT</b>
Bit	R/W	Default/Hex	Description
15:0	R/W	0xE1F8	The left peak filter release time parameter setting, which determine by the equation that $RT = \exp(-2.2Ts/tr)$ . The format is 3.24. (100ms)

**4.13.5.83. 0x224 ADC DRC Right Peak filter High Release Time Coef Register(Default Value: 0x000000FF)**

Offset: 0x224			Register Name: <b>AC_ADC_DRC_RPFHRT</b>
Bit	R/W	Default/Hex	Description
15:11	/	/	/
10:0	R/W	0x00FF	The left peak filter attack time parameter setting, which determine by the equation that $RT = \exp(-2.2Ts/tr)$ . The format is 3.24. (100ms)

**4.13.5.84. 0x228 ADC DRC Right Peak filter Low Release Time Coef Register(Default Value: 0x0000E1F8)**

Offset: 0x228			Register Name: <b>AC_ADC_DRC_RPFLRT</b>
Bit	R/W	Default/Hex	Description
15:0	R/W	0xE1F8	The left peak filter release time parameter setting, which determine by the equation that $AT = \exp(-2.2Ts/tr)$ . The format is 3.24. (100ms)

**4.13.5.85. 0x22C ADC DRC Left RMS Filter High Coef Register(Default Value: 0x00000001)**

Offset: 0x22C			Register Name: <b>AC_ADC_DRC_LRMSHAT</b>
Bit	R/W	Default/Hex	Description
15:11	/	/	/
10:0	R/W	0x0001	The left RMS filter average time parameter setting, which determine by the equation that $AT = 1-\exp(-2.2Ts/tav)$ . The format is 3.24. (10ms)

**4.13.5.86. 0x230 ADC DRC Left RMS Filter Low Coef Register(Default Value: 0x00002BAF)**

Offset: 0x230			Register Name: <b>AC_ADC_DRC_LRMSLAT</b>
Bit	R/W	Default/Hex	Description
15:0	R/W	0x2BAF	The left RMS filter average time parameter setting, which determine by the equation that $AT = 1 - \exp(-2.2Ts/tav)$ . The format is 3.24. (10ms)

**4.13.5.87. 0x234 ADC DRC Right RMS Filter High Coef Register(Default Value: 0x00000001)**

Offset: 0x234			Register Name: <b>AC_ADC_DRC_RRMSHAT</b>
Bit	R/W	Default/Hex	Description
15:11	/	/	/
10:0	R/W	0x0001	The right RMS filter average time parameter setting, which determine by the equation that $AT = 1 - \exp(-2.2Ts/tav)$ . The format is 3.24. (10ms)

**4.13.5.88. 0x238 ADC DRC Right RMS Filter Low Coef Register(Default Value: 0x00002BAF)**

Offset: 0x238			Register Name: <b>AC_ADC_DRC_RRMSLAT</b>
Bit	R/W	Default/Hex	Description
15:0	R/W	0x2BAF	The right RMS filter average time parameter setting, which determine by the equation that $AT = 1 - \exp(-2.2Ts/tav)$ . The format is 3.24. (10ms)

**4.13.5.89. 0x23C ADC DRC Compressor Theshold High Setting Register(Default Value: 0x000006A4)**

Offset: 0x23C			Register Name: <b>AC_ADC_DRC_HCT</b>
Bit	R/W	Default/Hex	Description
15:0	R/W	0x06A4	The compressor threshold setting, which set by the equation that $CTin = -CT/6.0206$ . The format is 8.24 (-40dB)

**4.13.5.90. 0x240 ADC DRC Compressor Slope High Setting Register(Default Value: 0x0000D3C0)**

Offset: 0x240			Register Name: <b>AC_ADC_DRC_LCT</b>
Bit	R/W	Default/Hex	Description
15:0	R/W	0xD3C0	The compressor threshold setting, which set by the equation that $CTin = -CT/6.0206$ . The format is 8.24 (-40dB)

**4.13.5.91. 0x244 ADC DRC Compressor Slope High Setting Register(Default Value: 0x00000080)**

Offset: 0x244			Register Name: <b>AC_ADC_DRC_HKC</b>
Bit	R/W	Default/Hex	Description
15:13	/	/	/
13:0	R/W	0x0080	The slope of the compressor which determine by the equation that $K_c = 1/R$ , there, R is the ratio of the compressor, which always is interger. The format is 8.24. (2 : 1)

**4.13.5.92. 0x248 ADC DRC Compressor Slope Low Setting Register(Default Value: 0x00000000)**

Offset: 0x248			Register Name: <b>AC_ADC_DRC_LKC</b>
Bit	R/W	Default/Hex	Description
15:0	R/W	0x0000	The slope of the compressor which determine by the equation that $K_c = 1/R$ , there, R is the ratio of the compressor, which always is interger. The format is 8.24. (2 : 1)

**4.13.5.93. 0x24C ADC DRC Compressor High Output at Compressor Threshold Register(Default Value: 0x0000F95B)**

Offset: 0x24C			Register Name: <b>AC_ADC_DRC_HOPC</b>
Bit	R/W	Default/Hex	Description
15:0	R/W	0xF95B	The output of the compressor which determine by the equation $-OPC/6.0206$ The format is 8.24 (-40dB)

**4.13.5.94. 0x250 ADC DRC Compressor Low Output at Compressor Threshold Register(Default Value: 0x00002C3F)**

Offset: 0x250			Register Name: <b>AC_ADC_DRC_LOPC</b>
Bit	R/W	Default/Hex	Description
15:0	R/W	0x2C3F	The output of the compressor which determine by the equation $OPC/6.0206$ The format is 8.24 (-40dB)

**4.13.5.95. 0x254 ADC DRC Limiter Theshold High Setting Register(Default Value: 0x000001A9)**

Offset: 0x254			Register Name: <b>AC_ADC_DRC_HLT</b>
Bit	R/W	Default/Hex	Description
15:0	R/W	0x01A9	The limiter threshold setting, which set by the equation that $LT_{in} = -LT/6.0206$ , The format is 8.24. (-10dB)



**4.13.5.96. 0x258 ADC DRC Limiter Theshold Low Setting Register(Default Value: 0x000034F0)**

Offset: 0x258			Register Name: <b>AC_ADC_DRC_LLT</b>
Bit	R/W	Default/Hex	Description
15:0	R/W	0x34F0	The limiter threshold setting, which set by the equation that $LT_{in} = -LT/6.0206$ , The format is 8.24. (-10dB)

**4.13.5.97. 0x25C ADC DRC Limiter Slope High Setting Register(Default Value: 0x00000005)**

Offset: 0x25C			Register Name: <b>AC_ADC_DRC_HKI</b>
Bit	R/W	Default/Hex	Description
15:11	/	/	/
13:0	R/W	0x0005	The slope of the limiter which determine by the equation that $KI = 1/R$ , there, R is the ratio of the limiter, which always is interger. The format is 8.24. (50 :1)

**4.13.5.98. 0x260 ADC DRC Limiter Slope Low Setting Register(Default Value: 0x1EB8)**

Offset: 0x260			Register Name: <b>AC_ADC_DRC_LKI</b>
Bit	R/W	Default/Hex	Description
15:0	R/W	0x1EB8	The slope of the limiter which determine by the equation that $KI = 1/R$ , there, R is the ratio of the limiter, which always is interger. The format is 8.24. (50 :1)

**4.13.5.99. 0x264 ADC DRC Limiter High Output at Limiter Threshold(Default Value: 0x0000FBD8)**

Offset: 0x264			Register Name: <b>AC_ADC_DRC_HOPL</b>
Bit	R/W	Default/Hex	Description
15:0	R/W	0xFBD8	The output of the limiter which determine by equation $OPT/6.0206$ . The format is 8.24 (-25dB)

**4.13.5.100. 0x268 ADC DRC Limiter Low Output at Limiter Threshold(Default Value: 0x0000FBA7)**

Offset: 0x268			Register Name: <b>AC_ADC_DRC_LOPL</b>
Bit	R/W	Default/Hex	Description
15:0	R/W	0xFBA7	The output of the limiter which determine by equation $OPT/6.0206$ . The format is 8.24 (-25dB)

**4.13.5.101. 0x26C ADC DRC Expander Theshold High Setting Register(Default Value: 0x00000BA0)**

Offset: 0x26C			Register Name: <b>AC_ADC_DRC_HET</b>
Bit	R/W	Default/Hex	Description
15:0	R/W	0x0BA0	The expander threshold setting, which set by the equation that $ET_{in} = -ET/6.0206$ , The format is 8.24. (-70dB)

**4.13.5.102. 0x270 ADC DRC Expander Theshold Low Setting Register(Default Value: 0x00007291)**

Offset: 0x270			Register Name: <b>AC_ADC_DRC_LET</b>
Bit	R/W	Default/Hex	Description
15:0	R/W	0x7291	The expander threshold setting, which set by the equation that $ET_{in} = -ET/6.0206$ , The format is 8.24. (-70dB)

**4.13.5.103. 0x274 ADC DRC Expander Slope High Setting Register(Default Value: 0x00000500)**

Offset: 0x274			Register Name: <b>AC_ADC_DRC_HKE</b>
Bit	R/W	Default/Hex	Description
15:14	/	/	/
13:0	R/W	0x0500	The slope of the expander which determine by the equation that $Ke = 1/R$ , there, R is the ratio of the expander, which always is interger and the ke must larger than 50. The format is 8.24. (1:5)

**4.13.5.104. 0x278 ADC DRC Expander Slope Low Setting Register(Default Value: 0x00000000)**

Offset: 0x278			Register Name: <b>AC_ADC_DRC_LKE</b>
Bit	R/W	Default/Hex	Description
15:0	R/W	0x0000	The slope of the expander which determine by the equation that $Ke = 1/R$ , there, R is the ratio of the expander, which always is interger and the ke must larger than 50. The format is 8.24. (1:5)

**4.13.5.105. 0x27C ADC DRC Expander High Output at Expander Threshold(Default Value: 0xF45F)**

Offset: 0x27C			Register Name: <b>AC_ADC_DRC_HOPE</b>
Bit	R/W	Default/Hex	Description
15:0	R/W	0xF45F	The output of the expander which determine by equation $OPE/6.0206$ . The format is 8.24 (-70dB)

**4.13.5.106. 0x280 ADC DRC Expander Low Output at Expander Threshold(Default Value: 0x00008D6E)**

Offset: 0x280			Register Name: <b>AC_ADC_DRC_LOPE</b>
Bit	R/W	Default/Hex	Description
15:0	R/W	0x8D6E	The output of the expander which determine by equation $OPE/6.0206$ . The format is 8.24 (-70dB)

**4.13.5.107. 0x284 ADC DRC Linear Slope High Setting Register(Default Value: 0x00000100)**

Offset: 0x284			Register Name: <b>AC_ADC_DRC_HKN</b>
Bit	R/W	Default/Hex	Description
15:14	/	/	/
13:0	R/W	0x0100	The slope of the linear which determine by the equation that $Kn = 1/R$ , there, R is the ratio of the linear, which always is interger . The format is 8.24. (1:1)

**4.13.5.108. 0x288 ADC DRC Linear Slope Low Setting Register(Default Value: 0x00000000)**

Offset: 0x288			Register Name: <b>AC_ADC_DRC_LKN</b>
Bit	R/W	Default/Hex	Description
15:0	R/W	0x0000	The slope of the linear which determine by the equation that $Kn = 1/R$ , there, R is the ratio of the linear, which always is interger . The format is 8.24. (1:1)

**4.13.5.109. 0x28C ADC DRC Smooth filter Gain High Attack Time Coef Register(Default Value: 0x00000002)**

Offset: 0x28C			Register Name: <b>AC_ADC_DRC_SFHAT</b>
Bit	R/W	Default/Hex	Description
15:11	/	/	/
10:0	R/W	0x0002	The smooth filter attack time parameter setting, which determine by the equation that $AT = 1 - \exp(-2.2Ts/tr)$ . The format is 3.24. (5ms)

**4.13.5.110. 0x290 ADC DRC Smooth filter Gain Low Attack Time Coef Register(Default Value: 0x00005600)**

Offset: 0x290			Register Name: <b>AC_ADC_DRC_SFLAT</b>
Bit	R/W	Default/Hex	Description
15:0	R/W	0x5600	The smooth filter attack time parameter setting, which determine by the equation that $AT = 1 - \exp(-2.2Ts/tr)$ . The format is 3.24. (5ms)

**4.13.5.111. 0x294 ADC DRC Smooth filter Gain High Release Time Coef Register(Default Value: 0x00000000)**

Offset: 0x294			Register Name: <b>AC_ADC_DRC_SFHRT</b>
Bit	R/W	Default/Hex	Description
15:11	/	/	/
10:0	R/W	0x0000	The gain smooth filter release time parameter setting, which determine by the equation that $RT = 1 - \exp(-2.2T_s/tr)$ . The format is 3.24. (200ms)

**4.13.5.112. 0x298 ADC DRC Smooth filter Gain Low Release Time Coef Register(Default Value: 0x0000F04)**

Offset: 0x298			Register Name: <b>AC_ADC_DRC_SFLRT</b>
Bit	R/W	Default/Hex	Description
15:0	R/W	0x0F04	The gain smooth filter release time parameter setting, which determine by the equation that $RT = 1 - \exp(-2.2T_s/tr)$ . The format is 3.24. (200ms)

**4.13.5.113. 0x29C ADC DRC MAX Gain High Setting Register(Default Value: 0x0000FE56)**

Offset: 0x29C			Register Name: <b>AC_ADC_DRC_MXGHS</b>
Bit	R/W	Default/Hex	Description
15:0	R/W	0xFE56	The max gain setting which determine by equation $MXG/6.0206$ . The format is 8.24 and must $-20dB < MXG < 30dB$ (-10dB)

**4.13.5.114. 0x2A0 ADC DRC MAX Gain Low Setting Register(Default Value: 0x0000CB0F)**

Offset: 0x2A0			Register Name: <b>AC_ADC_DRC_MXGLS</b>
Bit	R/W	Default/Hex	Description
15:0	R/W	0xCB0F	The max gain setting which determine by equation $MXG/6.0206$ . The format is 8.24 and must $-20dB < MXG < 30dB$ (-10dB)

**4.13.5.115. 0x2A4 ADC DRC MIN Gain High Setting Register(Default Value: 0x0000F95B)**

Offset: 0x2A4			Register Name: <b>AC_ADC_DRC_MNGHS</b>
Bit	R/W	Default/Hex	Description
15:0	R/W	0xF95B	The min gain setting which determine by equation $MXG/6.0206$ . The format is 8.24 and must $-60dB \leq MNG \leq -30dB$ (-40dB)

**4.13.5.116. 0x2A8 ADC DRC MIN Gain Low Setting Register(Default Value: 0x00002C3F)**

Offset: 0x2A8			Register Name: <b>AC_ADC_DRC_MNGLS</b>
Bit	R/W	Default/Hex	Description
15:0	R/W	0x2C3F	The min gain setting which determine by equation $MNG/6.0206$ . The format is 8.24 and must $-60dB \leq MNG \leq -30dB$ (-40dB)

**4.13.5.117. 0x2AC ADC DAP Expander Smooth Time High Coef Register(Default Value: 0x00000000)**

Offset: 0x2AC			Register Name: <b>AC_ADC_DRC_EPSHC</b>
Bit	R/W	Default/Hex	Description
11:0	R/W	0x0000	The gain smooth filter release and attack time parameter setting in expander region, which determine by the equation that $RT = 1 - \exp(-2.2Ts/tr)$ . The format is 3.24. (30ms)

**4.13.5.118. 0x2B0 ADC DRC Expander Smooth Time Low Coef Register (Default Value: 0x0000640C)**

Offset: 0x2B0			Register Name: <b>AC_ADC_DRC_EPSLC</b>
Bit	R/W	Default/Hex	Description
15:0	R/W	0x640C	The gain smooth filter release and attack time parameter setting in expander region, which determine by the equation that $RT = 1 - \exp(-2.2Ts/tr)$ . The format is 3.24. (30ms)

**4.13.5.119. 0x2B8 ADC DRC HPF Gain High(Default Value: 0x00000100)**

Offset: 0x2B8			Register Name: <b>AC_ADC_DRC_HPFHGAIN</b>
Bit	R/W	Default/Hex	Description
15:11	/	/	/
10:0	R/W	0X100	The gain of the hpf coefficient setting which format is 3.24.(gain = 1)

**4.13.5.120. 0x2BC ADC DRC HPF Gain Low(Default Value: 0x00000000)**

Offset: 0x2BC			Register Name: <b>AC_ADC_DRC_HPFLGAIN</b>
Bit	R/W	Default/Hex	Description
15:0	R/W	0X0000	The gain of the hpf coefficient setting which format is 3.24.(gain = 1)

**4.13.5.121. AC Parameter Configuration Register(Default Value: 0x1000000)**

Address: 0X400			Register Name: AC_PR_CFG
Bit	R/W	Default/Hex	Description
31:29	/	/	/
28	R/W	0X1	AC_PR_RST AC_PR Reset 0: Assert 1: De-assert
27:25	/	/	/
24	R/W	0X0	AC_PR_RW AC_PR Read Or Write 0: read 1: write
23:21	/	/	/
20:16	R/W	0X0	AC_PR_ADDR AC_PR Address [4:0]
15:8	R/W	0X0	ADDA_PR_WDAT ADDA_PR Write Data [7:0]
7:0	R/W	0X0	ADDA_PR_RDAT ADDA_PR Read Data [7:0]

**Note:** The address of this Register is 0X01c23000, using this register to configure the AC\_PR register.  
 Reset: Reset signal; ADDR[4:0] : AC\_PR Address; W/R: Write/Read Enable;  
 WDAT[7:0]: Write Data; RDAT[7:0]: Read Data.

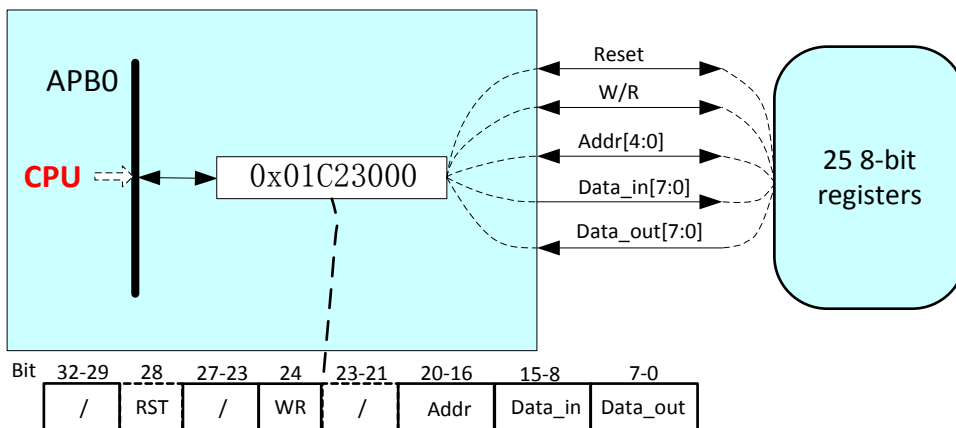

**4.13.5.122. 0x00 Headphone Volume Control(Default Value: 0x00)**

Offset:0x00			Register Name: AC_PAG_HP
Bit	R/W	Default/Hex	Description
7	/	/	/

6	/	/	/
5:0	R/W	0x0	HPVOL Headphone Volume Control, (HPVOL): Total 64 level, from 0dB to -62dB, 1dB/step, mute when 000000

**4.13.5.123. 0x01 Left Output Mixer Source Select Control Register(Default Value: 0x00)**

Offset:0x01			Register Name: <b>AC_LOMIXSC</b>
Bit	R/W	Default/Hex	Description
7	/	/	/
6:0	R/W	0x0	LMIXMUTE Left Output Mixer Mute Control 0-Mute, 1-Not Mute Bit 6: MIC1 Boost Stage Bit 5: / Bit 4: / Bit 3: / Bit 2: / Bit 1: Left Channel DAC Bit 0: Right Channel DAC

**4.13.5.124. 0x02 Right Output Mixer Source Select Control Register(Default Value: 0x00)**

Offset:0x02			Register Name: <b>AC_ROMIXSC</b>
Bit	R/W	Default/Hex	Description
7	/	/	/
6:0	R/W	0x0	RMIXMUTE Right Output Mixer Mute Control 0-Mute, 1-Not Mute Bit 6: MIC1 Boost Stage Bit 5: / Bit 4: / Bit 3: / Bit 2: / Bit 1: Right Channel DAC Bit 0: Left Channel DAC

**4.13.5.125. 0x03 DAC Analog Enable and PA Source Control Register(Default Value: 0x00)**

Offset:0x03			Register Name: <b>DAC_PA_SRC</b>
Bit	R/W	Default/Hex	Description

7	R/W	0x0	DACAREN Internal Analog Right channel DAC Enable 0:Disable; 1:Enable
6	R/W	0x0	DACALEN Internal Analog Left channel DAC Enable 0:Disable; 1:Enable
5	R/W	0x0	RMIXEN Right Analog Output Mixer Enable 0:Disable; 1:Enable
4	R/W	0x0	LMIXEN Left Analog Output Mixer Enable 0:Disable; 1:Enable
3	R/W	0x0	RHPPAMUTE All input source to Right Headphone PA mute, including Right Output mixer and Internal Right channel DAC: 0:Mute, 1: Not mute
2	R/W	0x0	LHPPAMUTE All input source to Left Headphone PA mute, including Left Output mixer and Internal Left channel DAC: 0:Mute, 1: Not mute
1	R/W	0x0	RHPIS Right Headphone Power Amplifier (PA) Input Source Select 0: Right channel DAC 1: Right Analog Mixer
0	R/W	0x0	LHPIS Left Headphone Power Amplifier (PA) Input Source Select 0: Left channel DAC 1: Left Analog Mixer

**4.13.5.126. 0x06 MIC1 Gain Control Register(Default Value: 0x33)**

Offset:0x06			Register Name: <b>MIC_GCTR</b>
Bit	R/W	Default/Hex	Description
7	/	/	/
6:4	R/W	0x3	MIC1_GAIN MIC1 BOOST stage to L or R output mixer Gain Control From -4.5dB to 6dB, 1.5dB/step, default is 0dB
3	/	/	/
2:0	R/W	0x3	/



**4.13.5.127. 0x07 PA Enable and HP Control Register(Default Value: 0x14)**

Offset:0x07			Register Name: <b>HP_CTRL</b>
Bit	R/W	Default/Hex	Description
7	R/W	0x0	HPPAEN Right & Left Headphone Power Amplifier Enable 0-disable 1-enable
6:5	R/W	0x0	HPCOM_FC, HPCOM function control 00: HPCOM off & output is floating 01: HPL inverting output 10: HPR inverting output 11: Direct driver for HPL & HPR
4	R/W	0x1	HPCOM output protection enable when it is set as Direct driver for HPL/R, (COMPTEN) 0: protection disable 1: protection enable
3:2	R/W	0x1	COS_SLOPE_CTRL COS slope time Control for Anti-pop 00:131ms; 01: 262ms; 10: 393ms; 11:524ms
1	R/W	0x0	LTRNMUTE, (hprisinvhpl) Left HPOUT Negative To Right HPOUT Mute 0: Mute, 1: Not mute
0	R/W	0x0	RTLNMUTE, (hplisinvhpr) Right HPOUT Negative To Left HPOUT Mute 0: Mute, 1: Not mute

**4.13.5.128. 0x0B BIAS and MIC1 boost(Default Value: 0x04)**

Offset:0x0B			Register Name: <b>BIAS_MIC_CTRL</b>
Bit	R/W	Default/Hex	Description
7	R/W	0x0	HMICBIASEN Headset Microphone Bias enable 0: disable, 1: enable
6	/	/	/
5	R/W	0x0	HMICADCEN Headset MIC Bias Current sensor & ADC enable 0: Current sensor & ADC disabled 1: Current sensor & ADC enabled
4	R/W	0x1	/
3	R/W	0	MIC1AMPEN MIC1 Boost AMP Enable 0-Disable; 1-Enable

2:0	R/W	0x4	MIC1BOOST MIC1 Boost AMP Gain Control 0dB when 000, 24dB to 42dB when 001 to 111, 3dB/step, default is 33dB
-----	-----	-----	---

**4.13.5.129. 0x0C Left ADC Mixer Mute Control(Default Value: 0x00)**

Offset:0x0C			Register Name: <b>LADC_MIX_MUTE</b>
Bit	R/W	Default/Hex	Description
7	/	/	/
6:0	R/W	0x0	LADCMIXMUTE Left ADC Mixer Mute Control: 0: Mute; 1:On Bit 6: MIC1 Boost stage Bit 5: / Bit 4: / Bit 3: / Bit 2: / Bit 1: Left output mixer Bit 0: Right output mixer

**4.13.5.130. 0x0D Right ADC Mixer Mute Control(Default Value: 0x00)**

Offset:0x0D			Register Name: <b>RADC_MIX_MUTE</b>
Bit	R/W	Default/Hex	Description
7	/	/	/
6:0	R/W	0x0	RADCMIXMUTE Right ADC Mixer Mute Control: 0: Mute; 1:On Bit 6: MIC1 Boost stage Bit 5: / Bit 4: / Bit 3: / Bit 2: / Bit 1: Right output mixer Bit 0: Left output mixer

**4.13.5.131. 0x0E PA Anti-pop time Control(Default Value: 0x04)**

Offset:0x0E			Register Name: <b>PA_ANTI_POP_CTRL</b>
Bit	R/W	Default/Hex	Description
7:3	R/W	0x0	/

2:0	R/W	0x4	PA_ANTI_POP_CTRL, (slopelengthsel) PA Anti-pop time Control 000: 131ms; 001: 262ms; 010: 393ms; 011: 524ms; 100: 655ms; 101: 786ms; 110: 786ms; 111: 1048ms;
-----	-----	-----	---

**4.13.5.132. 0x0F ADC Analog Control Register(Default Value: 0x03)**

Offset:0x0F			Register Name: <b>AC_ADC_CTRL</b>
Bit	R/W	Default/Hex	Description
7	R/W	0x0	ADCREN ADC Right Channel Enable 0-Disable; 1-Enable
6	R/W	0x0	ADCLEN ADC Left Channel Enable 0-Disable; 1-Enable
5:3	R/W	0x0	/
2:0	R/W	0x3	ADCG ADC Input Gain Control From -4.5dB to 6dB, 1.5dB/step default is 0dB

**4.13.5.133. 0x10 OPDRV/OPCOM/OPADC Control(Default Value: 0x55)**

Offset:0x10			Register Name: <b>OPADC_CTRL</b>
Bit	R/W	Default/Hex	Description
7:6	R/W	0x1	OPDRV_OPCOM_CUR. OPDRV/OPCOM output stage current setting
5:4	R/W	0x1	OPADC1_BIAS_CUR. OPADC1 Bias Current Select
3:2	R/W	0x1	OPADC2_BIAS_CUR. OPADC2 Bias Current Select
1:0	R/W	0x1	OPA AF_BIAS_CUR. OPA AF in ADC Bias Current Select

**4.13.5.134. 0x11 OPMIC、OPVR and OPADC Control(Default Value: 0x55)**

Offset:0x11			Register Name: <b>OPMIC_CTRL</b>
Bit	R/W	Default/Hex	Description
7:6	R/W	0x1	OPMIC_BIAS_CUR OPMIC Bias Current Control
5:4	R/W	0x1	OPVR_BIAS_CUR. OPVR Bias Current Control

			Especially, bit 5 can also control HPCOMFB: =0, HPCOMFB pin can be used to PA when R07_[6:5] is not 11; =1, HPCOMFB pin always can not be used to PA
3:2	R/W	0x1	OPDAC_BIAS_CUR. OPDAC Bias Current Control
1:0	R/W	0x1	OPMIX_BIAS_CUR. OPMIX/OPLPF/OPDRV/OPCOM Bias Current Control

**4.13.5.135. 0x12 ZERO CROSS Control(Default Value: 0x42)**

Offset:0x12			Register Name: <b>ZERO_CROSS_CTRL</b>
Bit	R/W	Default/Hex	Description
7	R/W	0x0	function enable for master volume change at zero cross over 0: disable; 1: enable
6	R/W	0x1	Timeout control for master volume change at zero cross over 0: 32ms; 1: 64ms
5:4	R/W	0x0	PTDBS HPCOM protect de-bounce time setting 00: 2-3ms; 01: 4-6ms; 10: 8-12ms; 11: 16-24ms at the same time, bit 17 is used to control the AVCCPORFLAG, write 1 to this bit, flag will be clear, and the calibration is done again
3	R/W	0x0	PA_SLOPE_SELECT PA slope select cosine or ramp 0: select cosine 1: select ramp
2:0	R/W	0x2	USB_BIAS_CUR. USB bias current tuning From 23uA to 30uA, Default is 25uA

**4.13.5.136. 0x13 ADC Function Control(Default Value: 0xD6)**

Offset:0x13			Register Name: <b>ADC_FUN_CTRL</b>
Bit	R/W	Default/Hex	Description
7	R/W	0x1	MMIC BIAS chopper enable 0: disable; 1:enable
6:5	R/W	0x2	MMIC BIAS chopper clock select 00: 250KHz; 01: 500KHz; 10: 1MHz; 11: 2MHz
4	R/W	0x1	DITHER ADC dither on/off control 0: dither off; 1: dither on
3:2	R/W	0x1	DITHER_CLK_SELECT ADC dither clock select

			00: ADC FS * (8/9), about 43KHz when FS=48KHz 01: ADC FS * (16/15), about 51KHz when FS=48KHz 10: ADC FS * (4/3), about 64KHz when FS=48KHz 11: ADC FS * (16/9), about 85KHz when FS=48KHz
1:0	R/W	0x2	BIHE_CTRL, BIHE control 00: no BIHE 01: BIHE=7.5 HOSC 10: BIHE=11.5 HOSC 11: BIHE=15.5 HOSC

#### 4.13.5.137. 0x14 Bias & DA16 Calibration Control Register(Default Value: 0x00)

Offset:0x14			Register Name: <b>CALIBRATION_CTRL</b>
bit	R/W	Default/Hex	Description
7	R/W	0x0	PA_SPEED_SELECT PA setup speed control (for testing) 0: slow; 1: fast
6	R/W	0x0	CURRENT_TEST_SELECT Internal current sink test enable (from LINEIN pin) 0:Normal; 1: For Debug
5	R/W	0x0	/
4	R/W	0x0	BIAS and DA16 calibration clock select 0: 1KHz; 1: 500Hz
3	R/W	0x0	BIAS calibration mode select 0: average; 1: single
2	R/W	0x0	BIAS and DA16 calibration control Write 1 to this bit, the calibration will be doing again. Then this bit will be reset to zero automatically
1	R/W	0x0	BIASCALVERIFY Bias Calibration Verify 0: Calibration; 1: Register setting
0	R/W	0x0	DA16CALVERIFY DA16 Calibration Verify 0: Calibration; 1: Register setting

#### 4.13.5.138. 0x15 DA16 Calibration Data(Default Value: 0x80)

Offset:0x15			Register Name: <b>DA16CALI_DATA</b>
Bit	R/W	Default/Hex	Description
7:0	R	0x80	DA16CALI DA16 Calibration Data

**4.13.5.139. 0x17 Bias Calibration Data(Default Value: 0x20)**

Offset:0x17			Register Name: <b>DA16CALI_DATA</b>
Bit	R/W	Default/Hex	Description
7:6	/	/	/
5:0	R	0x20	BIASCALI Bias Calibration Data, 6bit

**4.13.5.140. 0x18 Bias Register Setting Data(Default Value: 0x20)**

Offset:0x18			Register Name: <b>DA16CALI_SET</b>
Bit	R/W	Default/Hex	Description
7:6	/	/	/
5:0	R/W	0x20	BIASVERIFY Bias Register Setting Data, 6bit

## 4.14. Port Controller

The chip has 5 ports for multi-functional input/output pins. They are shown below:

- Port B(PB): 10 input/output port
- Port C(PC): 4 input/output port
- Port E(PE) : 25 input/output port
- Port F(PF) : 7 input/output port
- Port G(PG) : 6 input/output port

For various system configurations, these ports can be easily configured by software. All these ports can be configured as GPIO if multiplexed functions are not used. The total 2 group external PIO interrupt sources are supported and interrupt mode can be configured by software.

### 4.14.1. Port Controller Register List

Module Name	Base Address
PIO	0x01C20800

Register Name	Offset	Description
Pn_CFG0	n*0x24+0x00	Port n Configure Register 0 (n=1,2,4,5,6)
Pn_CFG1	n*0x24+0x04	Port n Configure Register 1 (n=1,2,4,5,6)
Pn_CFG2	n*0x24+0x08	Port n Configure Register 2 (n=1,2,4,5,6)
Pn_CFG3	n*0x24+0x0C	Port n Configure Register 3 (n=1,2,4,5,6)
Pn_DAT	n*0x24+0x10	Port n Data Register (n=1,2,4,5,6)
Pn_DRV0	n*0x24+0x14	Port n Multi-Driving Register 0 (n=1,2,4,5,6)
Pn_DRV1	n*0x24+0x18	Port n Multi-Driving Register 1 (n=1,2,4,5,6)
Pn_PUL0	n*0x24+0x1C	Port n Pull Register 0 (n=1,2,4,5,6)
Pn_PUL1	n*0x24+0x20	Port n Pull Register 1 (n=1,2,4,5,6)
Pn_INT_CFG0	0x200+n*0x20+0x00	PIO Interrupt Configure Register 0
Pn_INT_CFG1	0x200+n*0x20+0x04	PIO Interrupt Configure Register 1
Pn_INT_CFG2	0x200+n*0x20+0x08	PIO Interrupt Configure Register 2
Pn_INT_CFG3	0x200+n*0x20+0x0C	PIO Interrupt Configure Register 3
Pn_INT_CTL	0x200+n*0x20+0x10	PIO Interrupt Control Register
Pn_INT_STA	0x200+n*0x20+0x14	PIO Interrupt Status Register
Pn_INT_DEB	0x200+n*0x20+0x18	PIO Interrupt Debounce Register

## 4.14.2. Port Controller Register Description

### 4.14.2.1. PB Configure Register 0 (Default Value: 0x77777777)

Offset: 0x24			Register Name: <b>PB_CFG0_REG</b>
Bit	R/W	Default/Hex	Description
31	/	/	/
30:28	R/W	0x7	PB7_SELECT 000: Input                      001: Output 010: TWIO_SDA                011: Reserved 100: Reserved                101: Reserved 110: PB_EINT7                111: IO Disable
27	/	/	/
26:24	R/W	0x7	PB6_SELECT 000: Input                      001: Output 010: TWIO_SCK                011: Reserved 100: Reserved                101: Reserved 110: PB_EINT6                111: IO Disable
23	/	/	/
22:20	R/W	0x7	PB5_SELECT 000: Input                      001: Output 010: PWM1                      011: Reserved 100: Reserved                101: Reserved 110: PB_EINT5                111: IO Disable
19	/	/	/
18:16	R/W	0x7	PB4_SELECT 000: Input                      001: Output 010: PWM0                      011: Reserved 100: Reserved                101: Reserved 110: PB_EINT4                111: IO Disable
15	/	/	/
14:12	R/W	0x7	PB3_SELECT 000: Input                      001: Output 010: UART2_CTS                011: Reserved 100: Reserved                101: Reserved 110: PB_EINT3                111: IO Disable
11	/	/	/
10:8	R/W	0x7	PB2_SELECT 000: Input                      001: Output 010: UART2_RTS                011: Reserved 100: Reserved                101: Reserved 110: PB_EINT2                111: IO Disable
7	/	/	/
6:4	R/W	0x7	PB1_SELECT



			000: Input 010: UART2_RX 100: Reserved 110: PB_EINT1	001: Output 011: Reserved 101: Reserved 111: IO Disable
3	/	/	/	
2:0	R/W	0x7	PB0_SELECT 000: Input 010: UART2_TX 100: Reserved 110: PB_EINT0	001: Output 011: Reserved 101: Reserved 111: IO Disable

#### 4.14.2.2. PB Configure Register 1 (Default Value: 0x00777777)

Offset: 0x28			Register Name: <b>PB_CFG1_REG</b>	
Bit	R/W	Default/Hex	Description	
31:23	/	/	/	
22:20	R/W	0x7	/	
19	/	/	/	
18:16	R/W	0x7	/	
15	/	/		
14:12	R/W	0x7	/	
11	/	/	/	
10:8	R/W	0x7	/	
7	/	/	/	
6:4	R/W	0x7	PB9_SELECT 000: Input 010: TWI1_SDA 100: Reserved 110: PB_EINT9	001: Output 011: UART0_RX 101: Reserved 111: IO Disable
3	/	/	/	
2:0	R/W	0x7	PB8_SELECT 000: Input 010: TWI1_SCK 100: Reserved 110: PB_EINT8	001: Output 011: UART0_TX 101: Reserved 111: IO Disable

#### 4.14.2.3. PB Configure Register 2 (Default Value: 0x00000000)

Offset: 0x2C			Register Name: <b>PB_CFG2_REG</b>
Bit	R/W	Default/Hex	Description
31:0	/	/	

**4.14.2.4. PB Configure Register 3 (Default Value: 0x00000000)**

Offset: 0x30			Register Name: <b>PB_CFG3_REG</b>
Bit	R/W	Default/Hex	Description
31:0	/	/	/

**4.14.2.5. PB Data Register (Default Value: 0x00000000)**

Offset: 0x34			Register Name: <b>PB_DATA_REG</b>
Bit	R/W	Default/Hex	Description
31:14	/	/	/
13:0	R/W	0x0	<p>PB_DAT</p> <p>If the port is configured as input, the corresponding bit is the pin state. If the port is configured as output, the pin state is the same as the corresponding bit. The read bit value is the value setup by software. If the port is configured as functional pin, the undefined value will be read.</p>

**4.14.2.6. PB Multi-Driving Register 0 (Default Value: 0x05555555)**

Offset: 0x38			Register Name: <b>PB_DRV0_REG</b>
Bit	R/W	Default/Hex	Description
31:28	/	/	/
[2i+1:2i] (i=0~13)	R/W	0x1	<p>PB_DRV</p> <p>PB[n] Multi-Driving Select (n = 0~13)</p> <p>00: Level 0                      01: Level 1</p> <p>10: Level 2                     11: Level 3</p>

**4.14.2.7. PB Multi-Driving Register 1 (Default Value: 0x00000000)**

Offset: 0x3C			Register Name: <b>PB_DRV1_REG</b>
Bit	R/W	Default/Hex	Description
31:0	/	/	/

**4.14.2.8. PB PULL Register 0 (Default Value: 0x00000000)**

Offset: 0x40			Register Name: <b>PB_PULL0_REG</b>
Bit	R/W	Default/Hex	Description
31:28	/	/	/
[2i+1:2i]	R/W	0x0	PB_PULL



			000: Input 010: SDC2_CLK 100: Reserved 110: Reserved	001: Output 011: SPI0_MISO 101: Reserved 111: IO Disable
--	--	--	---	---

**4.14.2.11. PC Configure Register 1 (Default Value: 0x00000777)**

Offset: 0x4C			Register Name: <b>PC_CFG1_REG</b>
Bit	R/W	Default/Hex	Description
31:11	/	/	/
10:8	R/W	0x7	/
7	/	/	/
6:4	R/W	0x7	/
3	/	/	/
2:0	R/W	0x7	/

**4.14.2.12. PC Configure Register 2 (Default Value: 0x00000000)**

Offset: 0x50			Register Name: <b>PC_CFG2_REG</b>
Bit	R/W	Default/Hex	Description
31:0	/	/	/

**4.14.2.13. PC Configure Register 3 (Default Value: 0x00000000)**

Offset: 0x54			Register Name: <b>PC_CFG3_REG</b>
Bit	R/W	Default/Hex	Description
31:0	/	/	/

**4.14.2.14. PC Data Register (Default Value: 0x00000000)**

Offset: 0x58			Register Name: <b>PC_DATA_REG</b>
Bit	R/W	Default/Hex	Description
31:11	/	/	/
10:0	R/W	0x0	PC_DAT If the port is configured as input, the corresponding bit is the pin state. If the port is configured as output, the pin state is the same as the corresponding bit. The read bit value is the value setup by software. If the port is configured as functional pin, the undefined value will be read.

**4.14.2.15. PC Multi-Driving Register 0 (Default Value: 0x00155555)**

Offset: 0x5C			Register Name: <b>PC_DRV0_REG</b>
Bit	R/W	Default/Hex	Description
31:22	/	/	/
[2i+1:2i] (i=0~10)	R/W	0x1	PC_DRV PC[n] Multi-Driving SELECT (n = 0~10) 00: Level 0                      01: Level 1 10: Level 2                      11: Level 3

**4.14.2.16. PC Multi-Driving Register 1 (Default Value: 0x00000000)**

Offset: 0x60			Register Name: <b>PC_DRV1_REG</b>
Bit	R/W	Default/Hex	Description
31:0	/	/	/

**4.14.2.17. PC PULL Register 0 (Default Value: 0x00000000)**

Offset: 0x64			Register Name: <b>PC_PULL0_REG</b>
Bit	R/W	Default/Hex	Description
31:22	/	/	/
[2i+1:2i] (i=0~10)	R/W	0x0	PC_PULL PC[n] Pull-up/down Select (n = 0~10) 00: Pull-up/down disable    01: Pull-up 10: Pull-down                    11: Reserved

**4.14.2.18. PC PULL Register 1 (Default Value: 0x00000000)**

Offset: 0x68			Register Name: <b>PC_PULL1_REG</b>
Bit	R/W	Default/Hex	Description
31:0	/	/	/

**4.14.2.19. PE Configure Register 0 (Default Value: 0x77777777)**

Offset: 0x90			Register Name: <b>PE_CFG0_REG</b>
Bit	R/W	Default/Hex	Description
31	/	/	/
30:28	R/W	0x7	PE7_SELECT 000: Input                                      001: Output

			010: CSI_D3 100: Reserved 110: Reserved	011: LCD_D5 101: Reserved 111: IO Disable
27	/	/	/	
26:24	R/W	0x7	PE6_SELECT 000: Input 010: CSI_D2 100: Reserved 110: Reserved	001: Output 011: LCD_D4 101: Reserved 111: IO Disable
23	/	/	/	
22:20	R/W	0x7	PE5_SELECT 000: Input 010: CSI_D1 100: Reserved 110: Reserved	001: Output 011: LCD_D3 101: Reserved 111: IO Disable
19	/	/	/	
18:16	R/W	0x7	PE4_SELECT 000: Input 010: CSI_D0 100: Reserved 110: Reserved	001: Output 011: LCD_D2 101: Reserved 111: IO Disable
15	/	/	/	
14:12	R/W	0x7	PE3_SELECT 000: Input 010: CSI_VSYNC 100: Reserved 110: Reserved	001: Output 011: LCD_VSYNC 101: Reserved 111: IO Disable
11	/	/	/	
10:8	R/W	0x7	PE2_SELECT 000: Input 010: CSI_HSYNC 100: Reserved 110: Reserved	001: Output 011: LCD_HSYNC 101: Reserved 111: IO Disable
7	/	/	/	
6:4	R/W	0x7	PE1_SELECT 000: Input 010: CSI_MCLK 100: Reserved 110: Reserved	001: Output 011: LCD_DE 101: Reserved 111: IO Disable
3	/	/	/	
2:0	R/W	0x7	PE0_SELECT 000: Input 010: CSI_PCLK 100: Reserved 110: Reserved	001: Output 011: LCD_CLK 101: Reserved 111: IO Disable

**4.14.2.20. PE Configure Register 1 (Default Value: 0x77777777)**

Offset: 0x94			Register Name: PE_CFG1_REG
Bit	R/W	Default/Hex	Description
31	/	/	/
30:28	R/W	0x7	PE15_SELECT 000: Input                      001: Output 010: CSI_D11                    011: LCD_D15 100: Reserved                   101: Reserved 110: Reserved                   111: IO Disable
27	/	/	/
26:24	R/W	0x7	PE14_SELECT 000: Input                      001: Output 010: CSI_D10                    011: LCD_D14 100: Reserved                   101: Reserved 110: Reserved                   111: IO Disable
23	/	/	/
22:20	R/W	0x7	PE13_SELECT 000: Input                      001: Output 010: CSI_D9                     011: LCD_D13 100: Reserved                   101: Reserved 110: Reserved                   111: IO Disable
19	/	/	/
18:16	R/W	0x7	PE12_SELECT 000: Input                      001: Output 010: CSI_D8                     011: LCD_D12 100: Reserved                   101: Reserved 110: Reserved                   111: IO Disable
15	/	/	/
14:12	R/W	0x7	PE11_SELECT 000: Input                      001: Output 010: CSI_D7                     011: LCD_D11 100: Reserved                   101: Reserved 110: Reserved                   111: IO Disable
11	/	/	/
10:8	R/W	0x7	PE10_SELECT 000: Input                      001: Output 010: CSI_D6                     011: LCD_D10 100: Reserved                   101: Reserved 110: Reserved                   111: IO Disable
7	/	/	/
6:4	R/W	0x7	PE9_SELECT 000: Input                      001: Output

			010: CSI_D5 100: Reserved 110: Reserved	011: LCD_D7 101: Reserved 111: IO Disable
3	/	/	/	
2:0	R/W	0x7	PE8_SELECT 000: Input 010: CSI_D4 100: Reserved 110: Reserved	001: Output 011: LCD_D6 101: Reserved 111: IO Disable

**4.14.2.21. PE Configure Register 2 (Default Value: 0x77777777)**

Offset: 0x98			Register Name: PE_CFG2_REG	
Bit	R/W	Default/Hex	Description	
31	/	/	/	
30:28	R/W	0x7	PE23_SELECT 000: Input 010: Reserved 100: UART1_RTS 110: Reserved	001: Output 011: LCD_D22 101: Reserved 111: IO Disable
27	/	/	/	
26:24	R/W	0x7	PE22_SELECT 000: Input 010: CSI_SDA 100: UART1_RX 110: Reserved	001: Output 011: TWI1_SDA 101: Reserved 111: IO Disable
23	/	/	/	
22:20	R/W	0x7	PE21_SELECT 000: Input 010: CSI_SCK 100: UART1_TX 110: Reserved	001: Output 011: TWI1_SCK 101: Reserved 111: IO Disable
19	/	/	/	
18:16	R/W	0x7	PE20_SELECT 000: Input 010: CSI_FIELD 100: Reserved 110: Reserved	001: Output 011: CSI_MIPI_MCLK 101: Reserved 111: IO Disable
15	/	/	/	
14:12	R/W	0x7	PE19_SELECT 000: Input 010: CSI_D15 100: Reserved 110: Reserved	001: Output 011: LCD_D21 101: Reserved 111: IO Disable



11	/	/	/
10:8	R/W	0x7	PE18_SELECT 000: Input                      001: Output 010: CSI_D14                    011: LCD_D20 100: Reserved                   101: Reserved 110: Reserved                   111: IO Disable
7	/	/	/
6:4	R/W	0x7	PE17_SELECT 000: Input                      001: Output 010: CSI_D13                    011: LCD_D19 100: Reserved                   101: Reserved 110: Reserved                   111: IO Disable
3	/	/	/
2:0	R/W	0x7	PE16_SELECT 000: Input                      001: Output 010: CSI_D12                    011: LCD_D18 100: Reserved                   101: Reserved 110: Reserved                   111: IO Disable

**4.14.2.22. PE Configure Register 3 (Default Value: 0x00000007)**

Offset: 0x9C			Register Name: <b>PE_CFG3_REG</b>
Bit	R/W	Default/Hex	Description
31:3	/	/	/
2:0	R/W	0x7	PE24_SELECT 000: Input                      001: Output 010: Reserved                   011: LCD_D23 100: UART1_CTS                101: Reserved 110: Reserved                   111: IO Disable

**4.14.2.23. PE Data Register (Default Value: 0x00000000)**

Offset: 0xA0			Register Name: <b>PE_DATA_REG</b>
Bit	R/W	Default/Hex	Description
31:25	/	/	/
24:0	R/W	0x0	PE_DAT If the port is configured as input, the corresponding bit is the pin state. If the port is configured as output, the pin state is the same as the corresponding bit. The read bit value is the value setup by software. If the port is configured as functional pin, the undefined value will be read.

**4.14.2.24. PE Multi-Driving Register 0 (Default Value: 0x55555555)**

Offset: 0xA4			Register Name: <b>PE_DRV0_REG</b>
Bit	R/W	Default/Hex	Description
[2i+1:2i] (i=0~15)	R/W	0x1	PE_DRV PE[n] Multi-Driving SELECT (n = 0~15) 00: Level 0                      01: Level 1 10: Level 2                      11: Level 3

**4.14.2.25. PE Multi-Driving Register 1 (Default Value: 0x00015555)**

Offset: 0xA8			Register Name: <b>PE_DRV1_REG</b>
Bit	R/W	Default/Hex	Description
31:18	/	/	/
[2i+1:2i] (i=0~8)	R/W	0x1	PE_DRV PE[n] Multi-Driving Select (n = 16~24) 00: Level 0                      01: Level 1 10: Level 2                      11: Level 3

**4.14.2.26. PE PULL Register 0 (Default Value: 0x00000000)**

Offset: 0xAC			Register Name: <b>PE_PULL0_REG</b>
Bit	R/W	Default/Hex	Description
[2i+1:2i] (i=0~15)	R/W	0x0	PE_PULL PE[n] Pull-up/down Select (n = 0~15) 00: Pull-up/down disable    01: Pull-up 10: Pull-down                    11: Reserved

**4.14.2.27. PE PULL Register 1 (Default Value: 0x00000000)**

Offset: 0xB0			Register Name: <b>PE_PULL1_REG</b>
Bit	R/W	Default/Hex	Description
31:18	/	/	/
[2i+1:2i] (i=0~8)	R/W	0x0	PE_PULL PE[n] Pull-up/down Select (n = 16~24) 00: Pull-up/down disable    01: Pull-up 10: Pull-down                    11: Reserved

**4.14.2.28. PF Configure Register 0 (Default Value: 0x07373733)**

Offset: 0xB4			Register Name: PF_CFG0_REG
Bit	R/W	Default/Hex	Description
31:27	/	/	/
26:24	R/W	0x7	PF6_SELECT 000: Input                      001: Output 010: Reserved                      011: Reserved 100: Reserved                      101: Reserved 110: Reserved                      111: IO Disable
23	/	/	/
22:20	R/W	0x3	PF5_SELECT 000: Input                      001: Output 010: SDC0_D2                      011: JTAG_CK 100: Reserved                      101: Reserved 110: Reserved                      111: IO Disable
19	/	/	/
18:16	R/W	0x7	PF4_SELECT 000: Input                      001: Output 010: SDC0_D3                      011: UART0_RX 100: Reserved                      101: Reserved 110: Reserved                      111: IO Disable
15	/	/	/
14:12	R/W	0x3	PF3_SELECT 000: Input                      001: Output 010: SDC0_CMD                      011: JTAG_DO 100: Reserved                      101: Reserved 110: Reserved                      111: IO Disable
11	/	/	/
10:8	R/W	0x7	PF2_SELECT 000: Input                      001: Output 010: SDC0_CLK                      011: UART0_TX 100: Reserved                      101: Reserved 110: Reserved                      111: IO Disable
7	/	/	/
6:4	R/W	0x3	PF1_SELECT 000: Input                      001: Output 010: SDC0_D0                      011: JTAG_DI 100: Reserved                      101: Reserved 110: Reserved                      111: IO Disable
3	/	/	/
2:0	R/W	0x3	PF0_SELECT 000: Input                      001: Output 010: SDC0_D1                      011: JTAG_MS

			100: Reserved	101: Reserved
			110: Reserved	111: IO Disable

**4.14.2.29. PF Configure Register 1 (Default Value: 0x00000000)**

Offset: 0xB8			Register Name: <b>PF_CFG1_REG</b>
Bit	R/W	Default/Hex	Description
31:0	/	/	/

**4.14.2.30. PF Configure Register 2(Default Value: 0x00000000)**

Offset: 0xBC			Register Name: <b>PF_CFG2_REG</b>
Bit	R/W	Default/Hex	Description
31:0	/	/	/

**4.14.2.31. PF Configure Register 3(Default Value: 0x00000000)**

Offset: 0xC0			Register Name: <b>PF_CFG3_REG</b>
Bit	R/W	Default/Hex	Description
31:0	/	/	/

**4.14.2.32. PF Data Register (Default Value: 0x00000000)**

Offset: 0xC4			Register Name: <b>PF_DATA_REG</b>
Bit	R/W	Default/Hex	Description
31:7	/	/	/
6:0	R/W	0x0	PF_DAT If the port is configured as input, the corresponding bit is the pin state. If the port is configured as output, the pin state is the same as the corresponding bit. The read bit value is the value setup by software. If the port is configured as functional pin, the undefined value will be read.

**4.14.2.33. PF Multi-Driving Register 0 (Default Value: 0x00001555)**

Offset: 0xC8			Register Name: <b>PF_DRV0_REG</b>
Bit	R/W	Default/Hex	Description
31:14	/	/	/
[2i+1:2i]	R/W	0x1	PF_DRV

(i=0~6)			PF[n] Multi-Driving SELECT (n = 0~6) 00: Level 0                      01: Level 1 10: Level 2                      11: Level 3
---------	--	--	--

**4.14.2.34. PF Multi-Driving Register 1 (Default Value: 0x00000000)**

Offset: 0xCC			Register Name: <b>PF_DRV1_REG</b>
Bit	R/W	Default/Hex	Description
31:0	/	/	/

**4.14.2.35. PF PULL Register 0 (Default Value: 0x00000000)**

Offset: 0xD0			Register Name: <b>PF_PULL0_REG</b>
Bit	R/W	Default/Hex	Description
31:14	/	/	/
[2i+1:2i] (i=0~6)	R/W	0x5140	PF_PULL PF[n] Pull-up/down Select (n = 0~6) 00: Pull-up/down disable    01: Pull-up 10: Pull-down                    11: Reserved

**4.14.2.36. PF PULL Register 1 (Default Value: 0x00000000)**

Offset: 0xD4			Register Name: <b>PF_PULL1_REG</b>
Bit	R/W	Default/Hex	Description
31:0	/	/	/

**4.14.2.37. PG Configure Register 0 (Default Value: 0x77777777)**

Offset: 0xD8			Register Name: <b>PG_CFG0_REG</b>
Bit	R/W	Default/Hex	Description
31	/	/	/
30:28	R/W	0x7	/
27	/	/	/
26:24	R/W	0x7	/
23	/	/	/
22:20	R/W	0x7	PG5_SELECT 000: Input                      001: Output 010: SDC1_D3                    011: Reserved 100: Reserved                    101: Reserved

			110: PG_EINT5	111: IO Disable
19	/	/	/	
18:16	R/W	0x7	PG4_SELECT 000: Input 010: SDC1_D2 100: Reserved 110: PG_EINT4	001: Output 011: Reserved 101: Reserved 111: IO Disable
15	/	/	/	
14:12	R/W	0x7	PG3_SELECT 000: Input 010: SDC1_D1 100: Reserved 110: PG_EINT3	001: Output 011: Reserved 101: Reserved 111: IO Disable
11	/	/	/	
10:8	R/W	0x7	PG2_SELECT 000: Input 010: SDC1_D0 100: Reserved 110: PG_EINT2	001: Output 011: Reserved 101: Reserved 111: IO Disable
7	/	/	/	
6:4	R/W	0x7	PG1_SELECT 000: Input 010: SDC1_CMD 100: Reserved 110: PG_EINT1	001: Output 011: Reserved 101: Reserved 111: IO Disable
3	/	/	/	
2:0	R/W	0x7	PG0_SELECT 000: Input 010: SDC1_CLK 100: Reserved 110: PG_EINT0	001: Output 011: Reserved 101: Reserved 111: IO Disable

#### 4.14.2.38. PG Configure Register 1 (Default Value: 0x00777777)

Offset: 0xDC			Register Name: <b>PG_CFG1_REG</b>
Bit	R/W	Default/Hex	Description
31:0	R/W	0x00777777	/

#### 4.14.2.39. PG Configure Register 2 (Default Value: 0x00000000)

Offset: 0xE0			Register Name: <b>PG_CFG2_REG</b>
Bit	R/W	Default/Hex	Description

31:0	/	/	/
------	---	---	---

**4.14.2.40. PG Configure Register 3 (Default Value: 0x00000000)**

Offset: 0xE4			Register Name: <b>PG_CFG3_REG</b>
Bit	R/W	Default/Hex	Description
31:0	/	/	/

**4.14.2.41. PG Data Register (Default Value: 0x00000000)**

Offset: 0xE8			Register Name: <b>PG_DATA_REG</b>
Bit	R/W	Default/Hex	Description
31:14	/	/	/
13:0	R/W	0x0	<b>PG_DAT</b> If the port is configured as input, the corresponding bit is the pin state. If the port is configured as output, the pin state is the same as the corresponding bit. The read bit value is the value setup by software. If the port is configured as functional pin, the undefined value will be read.

**4.14.2.42. PG Multi-Driving Register 0 (Default Value: 0x05555555)**

Offset: 0xEC			Register Name: <b>PG_DRV0_REG</b>
Bit	R/W	Default/Hex	Description
31:28	/	/	/
$[2i+1:2i]$ $(i=0\sim13)$	R/W	0x1	<b>PF_DRV</b> PF[n] Multi-Driving SELECT (n = 0~13) 00: Level 0                      01: Level 1 10: Level 2                      11: Level 3

**4.14.2.43. PG Multi-Driving Register 1 (Default Value: 0x00000000)**

Offset: 0xF0			Register Name: <b>PG_DRV1_REG</b>
Bit	R/W	Default/Hex	Description
31:0	/	/	/

**4.14.2.44. PG PULL Register 0 (Default Value: 0x00000000)**

Offset: 0xF4			Register Name: <b>PG_PULL0_REG</b>
Bit	R/W	Default/Hex	Description
31:28	/	/	/

[2i+1:2i] (i=0~13)	R/W	0x0	<b>PF_PULL</b> PF[n] Pull-up/down Select (n = 0~13) 00: Pull-up/down disable    01: Pull-up 10: Pull-down                    11: Reserved
-----------------------	-----	-----	--

**4.14.2.45. PG PULL Register 1 (Default Value: 0x00000000)**

Offset: 0xF8			Register Name: <b>PG_PULL1_REG</b>
Bit	R/W	Default/Hex	Description
31:0	/	/	/

**4.14.2.46. PB External Interrupt Configure Register 0 (Default Value: 0x00000000)**

Offset: 0x220			Register Name: <b>PB_EINT_CFG0_REG</b>
Bit	R/W	Default/Hex	Description
[4i+3:4i] (i=0~7)	R/W	0	<b>EINT_CFG</b> External INTn Mode (n = 0~7) 0x0: Positive Edge 0x1: Negative Edge 0x2: High Level 0x3: Low Level 0x4: Double Edge (Positive/ Negative) Others: Reserved

**4.14.2.47. PB External Interrupt Configure Register 1 (Default Value: 0x00000000)**

Offset: 0x224			Register Name: <b>PB_EINT_CFG1_REG</b>
Bit	R/W	Default/Hex	Description
31:8	/	/	/
[4i+3:4i] (i=0~1)	R/W	0	<b>EINT_CFG</b> External INTn Mode (n = 8~9) 0x0: Positive Edge 0x1: Negative Edge 0x2: High Level 0x3: Low Level 0x4: Double Edge (Positive/ Negative) Others: Reserved



**4.14.2.48. PB External Interrupt Configure Register 2 (Default Value: 0x00000000)**

Offset: 0x228			Register Name: <b>PB_EINT_CFG2_REG</b>
Bit	R/W	Default/Hex	Description
31:0	/	/	/

**4.14.2.49. PB External Interrupt Configure Register 3 (Default Value: 0x00000000)**

Offset: 0x22C			Register Name: <b>PB_EINT_CFG3_REG</b>
Bit	R/W	Default/Hex	Description
31:0	/	/	/

**4.14.2.50. PB External Interrupt Control Register (Default Value: 0x00000000)**

Offset: 0x230			Register Name: <b>PB_EINT_CTL_REG</b>
Bit	R/W	Default/Hex	Description
31:10	/	/	/
[n] (n=0~9)	R/W	0	EINT_CTL External INTn Enable (n = 0~9) 0: Disable 1: Enable

**4.14.2.51. PB External Interrupt Status Register (Default Value: 0x00000000)**

Offset: 0x234			Register Name: <b>PB_EINT_STATUS_REG</b>
Bit	R/W	Default/Hex	Description
31:10	/	/	/
[n] (n=0~9)	R/W	0	EINT_STATUS External INTn Pending Bit (n = 0~9) 0: No IRQ pending 1: IRQ pending Write '1' to clear it.

**4.14.2.52. PB External Interrupt Debounce Register (Default Value: 0x00000000)**

Offset: 0x238			Register Name: <b>PB_EINT_DEB_REG</b>
Bit	R/W	Default/Hex	Description
31:7	/	/	/
6:4	R/W	0	DEB_CLK_PRE_SCALE

			Debounce Clock Pre-scale n The selected clock source is prescaled by 2 <sup>n</sup> .
3:1	/	/	/
0	R/W	0	PIO_INT_CLK_SELECT PIO Interrupt Clock Select 0: LOSC 32Khz 1: HOSC 24Mhz

#### 4.14.2.53. PG External Interrupt Configure Register 0 (Default Value: 0x00000000)

Offset: 0x240			Register Name: <b>PG_EINT_CFG0_REG</b>
Bit	R/W	Default/Hex	Description
31:24	/	/	/
[4i+3:4i] (i=0~5)	R/W	0	EINT_CFG External INTn Mode (n = 0~5) 0x0: Positive Edge 0x1: Negative Edge 0x2: High Level 0x3: Low Level 0x4: Double Edge (Positive/ Negative) Others: Reserved

#### 4.14.2.54. PG External Interrupt Configure Register 1 (Default Value: 0x00000000)

Offset: 0x244			Register Name: <b>PG_EINT_CFG1_REG</b>
Bit	R/W	Default/Hex	Description
31:0	/	/	/

#### 4.14.2.55. PG External Interrupt Configure Register 2 (Default Value: 0x00000000)

Offset: 0x248			Register Name: <b>PG_EINT_CFG2_REG</b>
Bit	R/W	Default/Hex	Description
31:0	/	/	/

#### 4.14.2.56. PG External Interrupt Configure Register 3 (Default Value: 0x00000000)

Offset: 0x24C			Register Name: <b>PG_EINT_CFG3_REG</b>
Bit	R/W	Default/Hex	Description
31:0	/	/	/

**4.14.2.57. PG External Interrupt Control Register (Default Value: 0x00000000)**

Offset: 0x250			Register Name: <b>PG_EINT_CTL_REG</b>
Bit	R/W	Default/Hex	Description
31:6	/	/	/
[n] (n=0~5)	R/W	0	EINT_CTL External INTn Enable (n = 0~5) 0: Disable 1: Enable

**4.14.2.58. PG External Interrupt Status Register (Default Value: 0x00000000)**

Offset: 0x254			Register Name: <b>PG_EINT_STATUS_REG</b>
Bit	R/W	Default/Hex	Description
31:6	/	/	/
[n] (n=0~5)	R/W	0	EINT_STATUS External INTn Pending Bit (n = 0~5) 0: No IRQ pending 1: IRQ pending Write '1' to clear it.

**4.14.2.59. PG External Interrupt Debounce Register (Default Value: 0x00000000)**

Offset: 0x258			Register Name: <b>PG_EINT_DEB_REG</b>
Bit	R/W	Default/Hex	Description
31:7	/	/	/
6:4	R/W	0	DEB_CLK_PRE_SCALE Debounce Clock Pre-scale n The selected clock source is prescaled by 2^n.
3:1	/	/	/
0	R/W	0	PIO_INT_CLK_SELECT PIO Interrupt Clock Select 0: LOSC 32Khz 1: HOSC 24Mhz

# Chapter 5 Memory

This section describes the V3s memory:

- SD/MMC

## 5.1. SD/MMC

### 5.1.1. Overview

The SD/MMC controller can be configured either as a Secure Digital Multimedia Card controller, which simultaneously supports Secure Digital memory (SD Memory), Secure Digital I/O (SDIO), Multimedia Cards (MMC), eMMC Card.

The SD/MMC controller includes the following features:

- Supports Secure Digital memory protocol commands (up to SD2.0)
- Supports Secure Digital I/O protocol commands
- Supports Multimedia Card protocol commands (up to eMMC4.41)
- Supports eMMC boot operation and alternative boot operation
- Supports Command Completion signal and interrupt to host processor and Command Completion Signal disable feature
- Supports one SD (Version 1.0 to 2.0) or MMC (Version 3.3 to eMMC4.41)
- Supports hardware CRC generation and error detection
- Supports programmable baud rate
- Supports host pull-up control
- Supports SDIO interrupts in 1-bit and 4-bit modes
- Supports SDIO suspend and resume operation
- Supports SDIO read wait
- Supports block size of 1 to 65535 bytes
- Supports descriptor-based internal DMA controller
- Internal 128 bytes FIFO for data transfer

### 5.1.2. Block Diagram

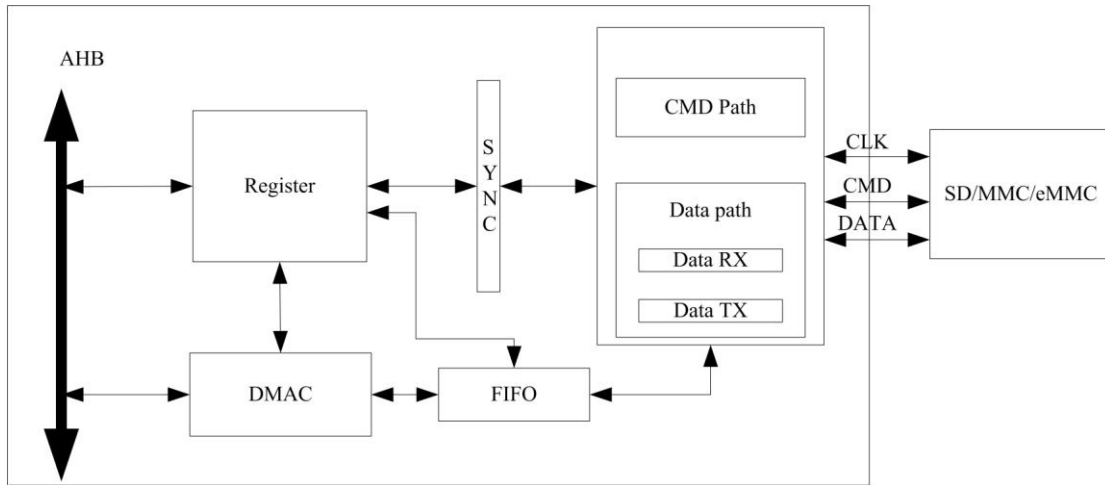

Figure 5-1. SD/MMC Controller Block Diagram

### 5.1.3. SD/MMC Controller Timing Diagram

Please refer to relative specifications:

- Physical Layer Specification Ver2.00
- SDIO Specification Ver2.00
- Multimedia Cards (MMC – version 4.2)
- JEDEC Standard – JESD84-44, Embedded Multimedia Card (e•MMC) Product Standard

### 5.1.4. SD/MMC Controller Special Requirement

#### 5.1.4.1. SD/MMC Pin List

Port Name	Width	Direction	Description
SDC_CLK	1	OUT	Clock output
SDC_CMD	1	IN/OUT	Command line
SDC_DATA	1/4	IN/OUT	Data line

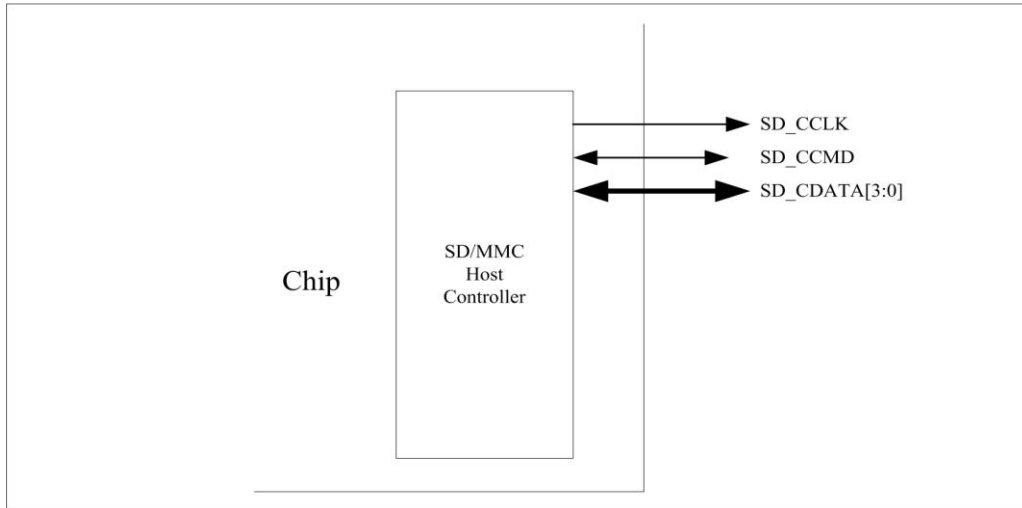

Figure 5-2. SD/MMC Pin Diagram

### 5.1.5. Internal DMA Controller Description

SD/MMC controller has an internal DMA controller (IDMAC) to transfer data between host memory and SDMMC port. With a descriptor, IDMAC can efficiently move data from source to destination by automatically loading next DMA transfer arguments, which need less CPU intervention. Before transfer data in IDMAC, host driver should construct a descriptor list, configure arguments of every DMA transfer, then launch the descriptor and start the DMA. IDMAC has an interrupt controller, when enabled, it can interrupt the HOST CPU in situations such as data transmission completed or some errors happened.

#### 5.1.5.1. IDMAC Descriptor Structure

The IDMAC uses a descriptor with a chain structure, and each descriptor points to a unique buffer and the next descriptor.

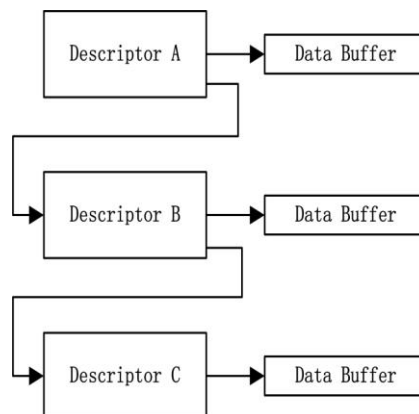

Figure 5-3. SD/MMC IDMAC Descriptor and Buffer

This figure illustrates the internal formats of a descriptor. The descriptor addresses must be aligned to the bus width used for 32-bit buses. Each descriptor contains 16 bytes of control and status information.

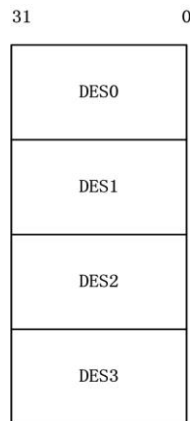

Figure 5-4. Internal Formats of A Descriptor

DES0 is a notation used to denote the [31:0] bits, DES1 to denote [63:32] bits, DES2 to denote [95:64] bits, and DES3 to denote [127:96]bits in a descriptor.

**5.1.5.2. DES0 definition**

Bits	Name	Descriptor
31	HOLD	DES_OWN_FLAG When set, this bit indicates that the descriptor is owned by the IDMAC. When this bit is reset, it indicates that the descriptor is owned by the host. This bit is cleared when transfer is over.
30	ERROR	ERR_FLAG When some error happened in transfer, this bit will be set.
29:5	/	/
4	Chain Flag	CHAIM_MOD When set, this bit indicates that the second address in descriptor is the next descriptor address. Must be set 1.
3	First DES Flag	FIRST_FLAG When set, this bit indicates that this descriptor contains the first buffer of data. Must be set to 1 in first DES.
2	Last DES Flag	LAST_FLAG When set, this bit indicates that the buffers pointed to by this descriptor are the last data buffer
1	Disable Interrupt on completion	CUR_TXRX_OVER_INT_DIS When set, this bit will prevent the setting of the TX/RX interrupt bit of the IDMAC status register for data that ends in the buffer pointed to by this descriptor

0	/	/
---	---	---

### 5.1.5.3. DES1 definition

Bits	Name	Descriptor
31:13	/	/
15:0	Buffer size	<b>BUFF_SIZE</b> These bits indicate the data buffer byte size, which must be a multiple of 4 bytes. If this field is 0, the DMA ignores this buffer and proceeds to the next descriptor.

### 5.1.5.4. DES2 definition

Bits	Name	Descriptor
31:0	Buffer address pointer	<b>BUFF_ADDR</b> These bits indicate the physical address of data buffer. The IDMAC ignores DES2[1:0], corresponding to the bus width of 32.

### 5.1.5.5. DES3 definition

Bits	Name	Descriptor
31:0	Next descriptor address	<b>NEXT_DESP_ADDR</b> These bits indicate the pointer to the physical memory where the next descriptor is present.

## 5.1.6. SD/MMC Register List

Module Name	Base Address
SD/MMC0	0x01C0F000
SD/MMC1	0x01C10000
SD/MMC2	0x01C11000

Register Name	Offset	Description
SD_GCTL	0x00	Control register
SD_CKCR	0x04	Clock Control register
SD_TMOR	0x08	Time out register
SD_BWDR	0x0C	Bus Width register
SD_BKSR	0x10	Block size register
SD_BYCR	0x14	Byte count register



SD_CMDR	0x18	Command register
SD_CAGR	0x1c	Command argument register
SD_RESP0	0x20	Response 0 register
SD_RESP1	0x24	Response 1 register
SD_RESP2	0x28	Response 2 register
SD_RESP3	0x2C	Response 3 register
SD_IMKR	0x30	Interrupt mask register
SD_MISR	0x34	Masked interrupt status register
SD_RISR	0x38	Raw interrupt status register
SD_STAR	0x3C	Status register
SD_FWLR	0x40	FIFO Water Level register
SD_FUNS	0x44	FIFO Function Select register
SD_A12A	0x58	Auto command 12 argument
SD_NTSR	0x5c	SD NewTiming Set Register
SD_SDBG	0x60	SD NewTiming Set Debug Register
SD_HWRST	0x78	Hardware Reset Register
SD_DMAC	0x80	BUS Mode Control
SD_DLBA	0x84	Descriptor List Base Address
SD_IDST	0x88	DMAC Status
SD_IDIE	0x8c	DMAC Interrupt Enable
SD_THLDC	0x100	Card Threshold Control register
SD_DSBD	0x10c	eMMC4.41 DDR Start Bit Detection Control
SD_RES_CRC	0x110	CRC status from card/eMMC in write operation
SD_DATA7_CRC	0x114	CRC Data7 from card/eMMC
SD_DATA6_CRC	0x118	CRC Data7 from card/eMMC
SD_DATA5_CRC	0x11c	CRC Data7 from card/eMMC
SD_DATA4_CRC	0x120	CRC Data7 from card/eMMC
SD_DATA3_CRC	0x124	CRC Data7 from card/eMMC
SD_DATA2_CRC	0x128	CRC Data7 from card/eMMC
SD_DATA1_CRC	0x12c	CRC Data7 from card/eMMC
SD_DATA0_CRC	0x130	CRC Data7 from card/eMMC
SD_CRC_STA	0x134	Response CRC from card/eMMC
SD_FIFO	0x200	Read/Write FIFO

### 5.1.7. SD/MMC Register Description

#### 5.1.7.1. SD Global Control Register(Default Value: 0x0000300)

Offset: 0x0000			Register Name: <b>SD_CTRL</b>
Bit	R/W	Default/Hex	Description
31	R/W	0	FIFO_AC_MOD FIFO Access Mode

			1-AHB bus 0-DMA bus
30:11	/	/	/
10	R/W	0	DDR_MOD_SEL DDR Mode Select 0 – SDR mode 1 – DDR mode
9	/	/	reserved
8	R/W	1	CD_DBC_ENB Card Detect (Data[3] status) De-bounce Enable 0 - disable de-bounce 1 – enable de-bounce
7:6	/	/	/
5	R/W	0	DMA_ENB DMA Global Enable 0 – Disable DMA to transfer data, using AHB bus 1 – Enable DMA to transfer data
4	R/W	0	INT_ENB Global Interrupt Enable 0 – Disable interrupts 1 – Enable interrupts
3	/	/	/
2	R/W	0	DMA_RST DMA Reset
1	R/W	0	FIFO_RST FIFO Reset 0 – No change 1 – Reset FIFO <i>This bit is auto-cleared after completion of reset operation.</i>
0	R/W	0	SOFT_RST Software Reset 0 – No change 1 – Reset SD/MMC controller <i>This bit is auto-cleared after completion of reset operation.</i>

**5.1.7.2. SD Clock Control Register(Default Value: 0x00000000)**

Offset: 0x0004			Register Name: <b>SD_CLKDIV</b>
Bit	R/W	Default/Hex	Description
31	R/W	0	MASK_DATA0 0 - Do not mask data0 when updata clock ; 1 - Mask data0 when updata clock; Default value : 0;
30:18	/	/	/

17	R/W	0	CCLK_CTRL Card Clock Output Control 0 – Card clock always on 1 – Turn off card clock when FSM in IDLE state
16	R/W	0	CCLK_ENB Card Clock Enable 0 – Card Clock off 1 – Card Clock on
15:8	/	/	/
7:0	R/W	0	CCLK_DIV Card clock divider n – Source clock is divided by 2*n.(n=0~255)

#### 5.1.7.3. SD Timeout Register (Default Value: 0xFFFFF40)

Offset: 0x0008			Register Name: <b>SD_TMOUT</b>
Bit	R/W	Default/Hex	Description
31:8	R/W	0xffffffff	DTO_LMT Data Timeout Limit
7:0	R/W	0x40	RTO_LMT Response Timeout Limit

#### 5.1.7.4. SD Bus Width Register (Default Value: 0x0000000)

Offset: 0x000c			Register Name: <b>SD_CTYPE</b>
Bit	R/W	Default/Hex	Description
31:2	/	/	/
1:0	R/W	0	CARD_WID Card width 2'b00 – 1-bit width 2'b01 – 4-bit width 2'b1x – 8-bit width

#### 5.1.7.5. SD Block Size Register (Default Value: 0x0000200)

Offset: 0x0010			Register Name: <b>SD_BLKSIZE</b>
Bit	R/W	Default/Hex	Description
31:16	/	/	/
15:0	R/W	0x200	BLK_SZ Block size

**5.1.7.6. SD Block Count Register (Default Value: 0x0000200)**

Offset: 0x0014			Register Name: <b>SD_BYTCNT</b>
Bit	R/W	Default/Hex	Description
31:0	R/W	0x200	<b>BYTE_CNT</b> Byte counter Number of bytes to be transferred; should be integer multiple of Block Size for block transfers.

**5.1.7.7. SD Command Register (Default Value: 0x00000000)**

Offset: 0x0018			Register Name: <b>SD_CMD</b>
Bit	R/W	Default/Hex	Description
31	R/W	0	<b>CMD_LOAD</b> Start Command. This bit is auto cleared when current command is sent. If there is no any response error happened, a command complete interrupt bit (CMD_OVER) will be set in interrupt register. You should not write any other command before this bit is cleared, or a command busy interrupt bit (CMD_BUSY) will be set in interrupt register.
30	/	/	/
29	R/W	0	<b>Use Hold Register</b> 0 - CMD and DATA sent to card bypassing HOLD Register 1 - CMD and DATA sent to card through the HOLD Register
28	R/W	0	<b>VOL_SW</b> Voltage Switch 0 – normal command 1 – Voltage switch command, set for CMD11 only
27	R/W	0	<b>BOOT_ABT</b> Boot Abort Setting this bit will terminate the boot operation.
26	R/W	0	<b>EXP_BOOT_ACK</b> Expect Boot Acknowledge. When Software sets this bit along in mandatory boot operation, controller expects a boot acknowledge start pattern of 0-1-0 from the selected card.
25:24	R/W	0	<b>BOOT_MOD</b> Boot Mode 2'b00 – normal command 2'b01 - Mandatory Boot operation 2'b10 - Alternate Boot operation 2'b11 - reserved
23	/	/	/
22	/	/	/

21	R/W	0	<b>PRG_CLK</b> Change Clock 0 – Normal command 1 – Change Card Clock; when this bit is set, controller will change clock domain and clock output. No command will be sent.
20:16	/	/	/
15	R/W	0	<b>SEND_INIT_SEQ</b> Send Initialization 0 – normal command sending 1 – Send initialization sequence before sending this command.
14	R/W	0	<b>STOP_ABT_CMD</b> Stop Abort Command 0 – normal command sending 1 – send Stop or abort command to stop current data transfer in progress.(CMD12, CMD52 for writing “I/O Abort” in SDIO CCCR)
13	R/W	0	<b>WAIT_PRE_OVER</b> Wait Data Transfer Over 0 – Send command at once, do not care of data transferring 1 – Wait for data transfer completion before sending current command
12	R/W	0	<b>STOP_CMD_FLAG</b> Send Stop CMD Automatically (CMD12) 0 – Do not send stop command at end of data transfer 1 – Send stop command automatically at end of data transfer
11	R/W	0	<b>TRANS_MODE</b> Transfer Mode 0 – Block data transfer command 1 – Stream data transfer command
10	R/W	0	<b>TRANS_DIR</b> Transfer Direction 0 – Read operation 1 – Write operation
9	R/W	0	<b>DATA_TRANS</b> Data Transfer 0 – without data transfer 1 – with data transfer
8	R/W	0	<b>CHK_RESP_CRC</b> Check Response CRC 0 – Do not check response CRC 1 – Check response CRC
7	R/W	0	<b>LONG_RESP</b> Response Type 0 –Short Response (48 bits) 1 –Long Response (136 bits)
6	R/W	0	<b>RESP_RCV</b> Response Receive

			0 – Command without Response 1 – Command with Response
5:0	R/W	0	CMD_IDX CMD Index Command index value

**5.1.7.8. SD Command Argument Register (Default Value: 0x00000000)**

Offset: 0x001c			Register Name: <b>SD_CMDARG</b>
Bit	R/W	Default/Hex	Description
31:0	R/W	0	CMD_ARG Command argument

**5.1.7.9. SD Response 0 Register (Default Value: 0x00000000)**

Offset: 0x0020			Register Name: <b>SD_RESP0</b>
Bit	R/W	Default/Hex	Description
31:0	R	0	CMD_RESP0 response 0 Bit[31:0] of response

**5.1.7.10. SD Response 1 Register (Default Value: 0x00000000)**

Offset: 0x0024			Register Name: <b>SD_RESP1</b>
Bit	R/W	Default/Hex	Description
31:0	R	0	CMD_RESP1 response 1 Bit[63:31] of response

**5.1.7.11. SD Response 2 Register (Default Value: 0x00000000)**

Offset: 0x0028			Register Name: <b>SD_RESP2</b>
Bit	R/W	Default/Hex	Description
31:0	R	0	CMD_RESP2 response 2 Bit[95:64] of response

**5.1.7.12. SD Response 3 Register (Default Value: 0x00000000)**

Offset: 0x002C			Register Name: <b>SD_RESP3</b>
Bit	R/W	Default/Hex	Description
31:0	R	0	CMD_RESP3 response 3 Bit[127:96] of response

**5.1.7.13. SD Interrupt Mask Register (Default Value: 0x00000000)**

Offset: 0x0030			Register Name: <b>SD_INTMASK</b>
Bit	R/W	Default/Hex	Description
31:0	R/W	0	INT_MASK 0 – interrupt masked 1 – interrupt enabled  Bit field defined as following: bit 31– card removed bit 30 – card inserted bit 17~29 - reserved bit 16 – SDIO interrupt bit 15 – Data End-bit error bit 14 – Auto Stop Command done bit 13 – Data Start Error bit 12 – Command Busy and illegal write bit 11 – FIFO under run/overflow bit 10 – Data starvation timeout /V1.8 Switch Done bit 9 – Data timeout/Boot data start bit 8 – Response timeout/Boot ACK received bit 7 – Data CRC error bit 6 – Response CRC error bit 5 – Data Receive Request bit 4 –Data Transmit Request bit 3 – Data Transfer Complete bit 2 – Command Complete bit 1 – Response Error (no response or response CRC error) bit 0 – Reserved

**5.1.7.14. SD Masked Interrupt Status Register (Default Value: 0x00000000)**

Offset: 0x0034			Register Name: <b>SD_MINTSTS</b>
Bit	R/W	Default/Hex	Description

31:0	R	0	<p>MSKD_ISTA</p> <p>Interrupt status. Enabled only if corresponding bit in mask register is set.</p> <p>Bit field defined as following:</p> <ul style="list-style-type: none"> <li>bit 31 – card removed</li> <li>bit 30 – card inserted</li> <li>bit 17~29 - reserved</li> <li>bit 16 – SDIO interrupt</li> <li>bit 15 – Data End-bit error</li> <li>bit 14 – Auto command done</li> <li>bit 13 – Data Start Error</li> <li>bit 12 – Command Busy and illegal write</li> <li>bit 11 – FIFO under run/overflow</li> <li>bit 10 – Data starvation timeout (HTO)/V1.8 Switch Done</li> <li>bit 9 – Data timeout/Boot data start</li> <li>bit 8 – Response timeout/Boot ACK received</li> <li>bit 7 – Data CRC error</li> <li>bit 6 – Response CRC error</li> <li>bit 5 – Data Receive Request</li> <li>bit 4 –Data Transmit Request</li> <li>bit 3 – Data Transfer Complete</li> <li>bit 2 – Command Complete</li> <li>bit 1 – Response Error (no response or response CRC error)</li> <li>bit 0 – Reserved</li> </ul>
------	---	---	--

**5.1.7.15. SD Raw Interrupt Status Register (Default Value: 0x00000000)**

Offset: 0x0038			Register Name: <b>SD_RINTSTS</b>
Bit	R/W	Default/Hex	Description
31:0	R/W	0	<p>RAW_ISTA</p> <p>Raw Interrupt Status.</p> <p><i>This is write-1-to-clear bits.</i></p> <p>Bit field defined as following:</p> <ul style="list-style-type: none"> <li>bit 31 – card removed</li> <li>bit 30 – card inserted</li> <li>bit 17~29 - reserved</li> <li>bit 16 – SDIO interrupt</li> <li>bit 15 – Data End-bit error</li> <li>bit 14 – Auto command done</li> <li>bit 13 – Data Start Error</li> <li>bit 12 – Command Busy and illegal write</li> <li>bit 11 – FIFO under run/overflow</li> <li>bit 10 – Data starvation timeout (HTO)/V1.8 Switch Done</li> </ul>



			bit 9 – Data timeout/Boot data start bit 8 – Response timeout/Boot ACK received bit 7 – Data CRC error bit 6 – Response CRC error bit 5 – Data Receive Request bit 4 – Data Transmit Request bit 3 – Data Transfer Complete bit 2 – Command Complete bit 1 – Response Error (no response or response CRC error) bit 0 – Reserved
--	--	--	---

**5.1.7.16. SD Status Register (Default Value: 0x00000006)**

Offset: 0x003C			Register Name: <b>SD_STATUS</b>
Bit	R/W	Default/Hex	Description
31	R	0	DMA_REQ dma_req DMA request signal state
30:22	/	/	/
21:17	R	0	FIFO_LEVEL FIFO Level Number of filled locations in FIFO
16:11	R	0	RESP_IDX Response Index Index of previous response, including any auto-stop sent by controller
10	R	0	FSM_BUSY Data FSM Busy Data transmit or receive state-machine is busy
9	R	0	CARD_BUSY Card data busy Inverted version of DATA[0] 0 – card data not busy 1 – card data busy
8	R	0	CARD_PRESENT Data[3] status level of DATA[3]; checks whether card is present 0 – card not present 1 – card present
7:4	R	0	FSM_STA Command FSM states: 0 – Idle 1 – Send init sequence 2 – Tx cmd start bit 3 – Tx cmd tx bit

			4 – Tx cmd index + arg 5 – Tx cmd crc7 6 – Tx cmd end bit 7 – Rx resp start bit 8 – Rx resp IRQ response 9 – Rx resp tx bit 10 – Rx resp cmd idx 11 – Rx resp data 12 – Rx resp crc7 13 – Rx resp end bit 14 – Cmd path wait NCC 15 – Wait; CMD-to-response turnaround
3	R	0	FIFO_FULL FIFO full 1 – FIFO full 0 – FIFO not full
2	R	1	FIFO_EMPTY FIFO Empty 1 - FIFO Empty 0 - FIFO not Empty
1	R	1	FIFO_TX_LEVEL FIFO TX Water Level flag 0 – FIFO didn't reach transmit trigger level 1 - FIFO reached transmit trigger level
0	R	0	FIFO_RX_LEVEL FIFO RX Water Level flag 0 – FIFO didn't reach receive trigger level 1 - FIFO reached receive trigger level

**5.1.7.17. SD FIFO Water Level Register (Default Value: 0x000F0000)**

Offset: 0x0040			Register Name: <b>SD_FIFOTH</b>
Bit	R/W	Default/Hex	Description
31	/	/	/
30:28	R/W	0	BSIZE_OF_TRANS Burst size of multiple transaction 000 – 1 transfers 001 – 4 010 – 8 011 – 16 100 – 32 101 – 64 110 – 128 111 – 256

			Should be programmed same as DMA controller multiple transaction size. The units for transfers are the DWORD. A single transfer would be signaled based on this value. Value should be sub-multiple of (RX_TL + 1) and (FIFO_DEPTH - TX_TL) Recommended: MSize = 8, TX_TL = 16, RX_TL = 15
27:21	R	0	/
20:16	R/W	0xF	RX_TL Rx Trigger Level 0x0~0x1e – RX Trigger Level is 0~30 0x1f – reserved FIFO threshold when FIFO request host to receive data from FIFO. When FIFO data level is greater than this value, DMA is request is raised if DMA enabled, or RX interrupt bit is set if interrupt enabled. At the end of packet, if the last transfer is less than this level, the value is ignored and relative request will be raised as usual. Recommended: 15 (means greater than 15)
15:5	R	0	/
4:0	R/W	0	TX_TL TX Trigger Level 0x1~0xf – TX Trigger Level is 1~31 0x0 – no trigger FIFO threshold when FIFO requests host to transmit data to FIFO. When FIFO data level is less than or equal to this value, DMA TX request is raised if DMA enabled, or TX request interrupt bit is set if interrupt enabled. At the end of packet, if the last transfer is less than this level, the value is ignored and relative request will be raised as usual. Recommended: 16 (means less than or equal to 16)

**5.1.7.18. SD Function Select Register (Default Value: 0x00000000)**

Offset: 0x0044			Register Name: <b>SD_CTRL</b>
Bit	R/W	Default/Hex	Description
31:16	R/W	0	CEATA_EN CEATA Support ON/OFF 0xceaa – CEATA support on. All hidden CEATA relative bits are accessible normally and these 16 bits return value of 0x1 when be read. Other value – CEATA support off. All hidden CEATA relative bits cannot be access and these 16 bits return value of 0 when be read.
15:11	/	0	/
10	/	/	/
9	/	/	/
8	/	/	/
7:3	/	/	/

2	R/W	0	<p>ABT_RDATA Abort Read Data 0 – Ignored 1 –After suspend command is issued during read-transfer, software polls card to find when suspend happened. Once suspend occurs, software sets bit to reset data state-machine, which is waiting for next block of data. Used in SDIO card suspends sequence. <i>This bit is auto-cleared once controller reset to idle state.</i></p>
1	R/W	0	<p>READ_WAIT Read Wait 0 – Clear SDIO read wait 1 – Assert SDIO read wait</p>
0	R/W	0	<p>HOST_SEND_MMC_IRQRESQ Host Send MMC IRQ Response 0 – Ignored 1 – Send auto IRQ response When host is waiting MMC card interrupt response, setting this bit will make controller cancel wait state and return to idle state, at which time, controller will receive IRQ response sent by itself. <i>This bit is auto-cleared after response is sent.</i></p>

**5.1.7.19. SD Auto Command 12 Register (Default Value: 0x0000ffff)**

Offset: 0x0058			Register Name: <b>SD_A12A</b>
Bit	R/W	Default/Hex	Description
31:16	/	/	/
0:15	R/W	0xffff	SD_A12A. SD_A12A set the argument of command 12 automatically send by controller

**5.1.7.20. SD NewTiming Set Register (Default Value: 0x00000001,only used in SDC2)**

Offset: 0x005C			Register Name: <b>SD_NTZR_REG</b>
Bit	R/W	Default/Hex	Description
31	R/W	0	<p>MODE_SELEC 0 - Old mode of Sample/Output Timing ; 1 - New mode of Sample/Output Timing; Default value : 0;</p>
30:6	R/W	0x00	<p>SAMPLE_TIMING_PHASE(RX) 00 - Sample timing phase offset 90。 ; 01 - Sample timing phase offset 180。 ; 10 - Sample timing phase offset 270。 ; 11 - Ignore;</p>

			Default value : 00;
3:2	/	/	/
1:0	R/W	0x01	OUTPUT_TIMING_PHASE(TX) 00 - Output timing phase offset 90。 ; 01 - Output timing phase offset 180。 ; 10 - Output timing phase offset 270。 ; 11 - Ignore; Default value : 01;

**5.1.7.21. SD Hardware Reset Register (Default Value: 0x00000001)**

Offset: 0x0078			Register Name: <b>SD_HWRST</b>
Bit	R/W	Default/Hex	Description
31:1	/	/	/
0	R/W	1	HW_RESET. 1 – Active mode 0 – Reset These bits cause the cards to enter pre-idle state, which requires them to be re-initialized.

**5.1.7.22. SD DMAC Control Register (Default Value: 0x00000000)**

Offset: 0x0080			Register Name: <b>SD_BUS_MODE</b>
Bit	R/W	Default/Hex	Description
31	W	0	DES_LOAD_CTRL When DMAC fetches a descriptor, if the valid bit of a descriptor is not set, DMAC FSM will go to the suspend state. Setting this bit will make DMAC re-fetch descriptor again and do the transfer normally.
30:11	/	/	/
10:8	R	0	PRG_BURST_LEN Programmable Burst Length. These bits indicate the maximum number of beats to be performed in one IDMAC transaction. The IDMAC will always attempt to burst as specified in PBL each time it starts a Burst transfer on the host bus. The permissible values are 1, 4, 8, 16, 32, 64, 128 and 256. This value is the mirror of MSIZE of FIFOTH register. In order to change this value, write the required value to FIFOTH register. This is an encode value as follows. 000 – 1 transfers 001 – 4 transfers 010 – 8 transfers 011 – 16 transfers 100 – 32 transfers

			101 – 64 transfers 110 – 128 transfers 111 – 256 transfers Transfer unit is either 16, 32, or 64 bits, based on HDATA_WIDTH. PBL is a read-only value.
7	R/W	0	IDMAC_ENB IDMAC Enable. When set, the IDMAC is enabled. DE is read/write.
6:2	R/W	0	DES_SKIP_LEN Descriptor Skip Length. Specifies the number of Word to skip between two unchained descriptors. This is applicable only for dual buffer structure. Default value is set to 4 DWORD.
1	R/W	0	FIX_BUST_CTRL Fixed Burst. Controls whether the AHB Master interface performs fixed burst transfers or not. When set, the AHB will use only SINGLE, INCR4, INCR8 during start of normal burst transfers. When reset, the AHB will use SINGLE and INCR burst transfer operations.
0	R/W	0	IDMAC_RST DMA Reset. When set, the DMA Controller resets all its internal registers. SWR is read/write. It is automatically cleared after 1 clock cycle.

**5.1.7.23. SD Descriptor List Base Address Register (Default Value: 0x00000000)**

Offset: 0x0084			Register Name: <b>SD_DLBA</b>
Bit	R/W	Default/Hex	Description
31:0	R/W	0	DES_BASE_ADDR Start of Descriptor List. Contains the base address of the First Descriptor. The LSB bits [1:0] are ignored and taken as all-zero by the IDMAC internally. Hence these LSB bits are read-only.

**5.1.7.24. SD DMAC Status Register (Default Value: 0x0000\_0000)**

Offset: 0x0088			Register Name: <b>SD_DSR</b>
Bit	R/W	Default/Hex	Description
31:17	/	/	/
16:13	R	0	DMAC_FSM_STA DMAC FSM present state. 0 – DMA_IDLE

			1 – DMA_SUSPEND 2 – DESC_RD 3 – DESC_CHK 4 – DMA_RD_REQ_WAIT 5 – DMA_WR_REQ_WAIT 6 – DMA_RD 7 – DMA_WR 8 – DESC_CLOSE This bit is read-only.
12:10	R	0	DMAC_ERR_STA Error Bits. Indicates the type of error that caused a Bus Error. Valid only with Fatal Bus Error bit (IDSTS[2]) set. This field does not generate an interrupt. 3'b001 – Host Abort received during transmission 3'b010 – Host Abort received during reception Others: Reserved EB is read-only.
9	R/W	0	ABN_INT_SUM Abnormal Interrupt Summary. Logical OR of the following: IDSTS[2] – Fatal Bus Interrupt IDSTS[4] – DU bit Interrupt IDSTS[5] – Card Error Summary Interrupt Only unmasked bits affect this bit. This is a sticky bit and must be cleared each time a corresponding bit that causes AIS to be set is cleared. Writing a 1 clears this bit.
8	R/W	0	NOR_INT_SUM Normal Interrupt Summary. Logical OR of the following: IDSTS[0] – Transmit Interrupt IDSTS[1] – Receive Interrupt Only unmasked bits affect this bit. This is a sticky bit and must be cleared each time a corresponding bit that causes NIS to be set is cleared. Writing a 1 clears this bit.
7:6	/	/	/
5	R/W	0	ERR_FLAG_SUM Card Error Summary. Indicates the status of the transaction to/from the card; also present in RINTSTS. Indicates the logical OR of the following bits: EBE – End Bit Error RTO – Response Timeout/Boot Ack Timeout RCRC – Response CRC SBE – Start Bit Error DRTO – Data Read Timeout/BDS timeout DCRC – Data CRC for Receive RE – Response Error

			<i>Writing 1 clears this bit.</i>
4	R/W	0	DES_UNAVL_INT Descriptor Unavailable Interrupt. This bit is set when the descriptor is unavailable due to OWN bit = 0 (DES0[31]=0). Writing a 1 clears this bit.
3	/	/	/
2	R/W	0	FATAL_BERR_INT Fatal Bus Error Interrupt. Indicates that a Bus Error occurred (IDSTS[12:10]). When this bit is set, the DMA disables all its bus accesses. Writing a 1 clears this bit.
1	R/W	0	RX_INT Receive Interrupt. Indicates the completion of data reception for a descriptor. Writing a 1 clears this bit.
0	R/W	0	TX_INT Transmit Interrupt. Indicates that data transmission is finished for a descriptor. Writing a '1' clears this bit.

**5.1.7.25. SD DMAC Interrupt Enable Register (Default Value: 0x00000000)**

Offset: 0x008C			Register Name: <b>SD_IDIE_REG</b>
Bit	R/W	Default/Hex	Description
31:10	/	/	/
9	R/W	0	ABN_INT_ENB Abnormal Interrupt Summary Enable. When set, an abnormal interrupt is enabled. This bit enables the following bits: IDINTEN[2] – Fatal Bus Error Interrupt IDINTEN[4] – DU Interrupt IDINTEN[5] – Card Error Summary Interrupt
8	R/W	0	NOR_INT_ENB Normal Interrupt Summary Enable. When set, a normal interrupt is enabled. When reset, a normal interrupt is disabled. This bit enables the following bits: IDINTEN[0] – Transmit Interrupt IDINTEN[1] – Receive Interrupt
7:6	/	/	/
5	R/W	0	ERR_SUM_INT_ENB Card Error summary Interrupt Enable. When set, it enables the Card Interrupt summary.
4	R/W	0	DES_UNAVL_INT_ENB Descriptor Unavailable Interrupt. When set along with Abnormal Interrupt Summary Enable, the DU interrupt



			is enabled.
3	/	/	/
2	R/W	0	FERR_INT_ENB Fatal Bus Error Enable. When set with Abnormal Interrupt Summary Enable, the Fatal Bus Error Interrupt is enabled. When reset, Fatal Bus Error Enable Interrupt is disabled.
1	R/W	0	RX_INT_ENB Receive Interrupt Enable. When set with Normal Interrupt Summary Enable, Receive Interrupt is enabled. When reset, Receive Interrupt is disabled.
0	R/W	0	TX_INT_ENB Transmit Interrupt Enable. When set with Normal Interrupt Summary Enable, Transmit Interrupt is enabled. When reset, Transmit Interrupt is disabled.

**5.1.7.26. Card Threshold Control Register (Default Value: 0x00000000)**

Offset: 0x0100			Register Name: <b>SD_THLD_REG</b>
Bit	R/W	Default/Hex	Description
31:28	/	/	/
27:16	R/W	0	CARD_RD_THLD Card Read Threshold Size
15:1	/	/	/
0	R/W	0	CARD_RD_THLD_ENB Card Read Threshold Enable 0 – Card Read Threshold Disable 1 - Card Read Threshold Enable Host controller initiates Read Transfer only if CARD_RD_THLD amount of space is available in receive FIFO

**5.1.7.27. eMMC4.41 DDR Start Bit Detection Control Register (Default Value: 0x00000000)**

Offset: 0x010C			Register Name: <b>EMMC_DDR_SBIT_DET_REG</b>
Bit	R/W	Default/Hex	Description
31:1	/	/	/
0	R/W	0	HALF_START_BIT Control for start bit detection mechanism inside mstorage based on duration of start bit. For eMMC 4.41, start bit can be: 0 - Full cycle 1 - Less than one full cycle

			Set HALF_START_BIT=1 for eMMC 4.41 and above; set to 0 for SD applications.
--	--	--	---

**5.1.7.28. SD Response CRC Register (Default Value: 0x00000000)**

Offset: 0x0110			Register Name: <b>RESP_CRC_REG</b>
Bit	R/W	Default/Hex	Description
31:7	/	/	/
6:0	R	0	RESP_CRC Response CRC Response CRC from card/eMMC.

**5.1.7.29. SD Data7 CRC Register (Default Value: 0x00000000)**

Offset: 0x0114			Register Name: <b>DATA7_CRC_REG</b>
Bit	R/W	Default/Hex	Description
31:0	R	0	DATA7_CRC Data[7] CRC CRC in data[7] from card/eMMC.In DDR mode,the higher 16 bits indicate the CRC of even data,and the lower 16bits indicate the CRC of odd data.In SDR mode,the higher of 16 bits indicate the CRC of all data.

**5.1.7.30. SD Data6 CRC Register (Default Value: 0x00000000)**

Offset: 0x0118			Register Name: <b>DATA6_CRC_REG</b>
Bit	R/W	Default/Hex	Description
31:0	R	0	DATA6_CRC Data[6] CRC CRC in data[6] from card/eMMC.In DDR mode,the higher 16 bits indicate the CRC of even data,and the lower 16bits indicate the CRC of odd data.In SDR mode,the higher of 16 bits indicate the CRC of all data.

**5.1.7.31. SD Data5 CRC Register (Default Value: 0x00000000)**

Offset: 0x011c			Register Name: <b>DATA5_CRC_REG</b>
Bit	R/W	Default/Hex	Description
31:0	R	0	DATA5_CRC Data[5] CRC CRC in data[5] from card/eMMC.In DDR mode,the higher 16 bits indicate the

			CRC of even data,and the lower 16bits indicate the CRC of odd data.In SDR mode,the higher of 16 bits indicate the CRC of all data.
--	--	--	--

**5.1.7.32. SD Data4 CRC Register (Default Value: 0x00000000)**

Offset: 0x0120			Register Name: <b>DATA4_CRC_REG</b>
Bit	R/W	Default/Hex	Description
31:0	R	0	DATA4_CRC Data[4] CRC CRC in data[4] from card/eMMC.In DDR mode,the higher 16 bits indicate the CRC of even data,and the lower 16bits indicate the CRC of odd data.In SDR mode,the higher of 16 bits indicate the CRC of all data.

**5.1.7.33. SD Data3 CRC Register (Default Value: 0x00000000)**

Offset: 0x0124			Register Name: <b>DATA3_CRC_REG</b>
Bit	R/W	Default/Hex	Description
31:0	R	0	DATA3_CRC Data[3] CRC CRC in data[3] from card/eMMC.In DDR mode,the higher 16 bits indicate the CRC of even data,and the lower 16bits indicate the CRC of odd data.In SDR mode,the higher of 16 bits indicate the CRC of all data.

**5.1.7.34. SD Data2 CRC Register (Default Value: 0x00000000)**

Offset: 0x0128			Register Name: <b>DATA2_CRC_REG</b>
Bit	R/W	Default/Hex	Description
31:0	R	0	DATA2_CRC Data[2] CRC CRC in data[2] from card/eMMC.In DDR mode,the higher 16 bits indicate the CRC of even data,and the lower 16bits indicate the CRC of odd data.In SDR mode,the higher of 16 bits indicate the CRC of all data.

**5.1.7.35. SD Data1 CRC Register (Default Value: 0x00000000)**

Offset: 0x012c			Register Name: <b>DATA1_CRC_REG</b>
Bit	R/W	Default/Hex	Description
31:0	R	0	DATA1_CRC Data[1] CRC CRC in data[1] from card/eMMC.In DDR mode,the higher 16 bits indicate the

			CRC of even data,and the lower 16bits indicate the CRC of odd data.In SDR mode,the higher of 16 bits indicate the CRC of all data.
--	--	--	--

**5.1.7.36. SD Data0 CRC Register (Default Value: 0x00000000)**

Offset: 0x0130			Register Name: <b>DATA0_CRC_REG</b>
Bit	R/W	Default/Hex	Description
31:0	R	0	DATA0_CRC Data[0] CRC CRC in data[0] from card/eMMC.In DDR mode,the higher 16 bits indicate the CRC of even data,and the lower 16bits indicate the CRC of odd data.In SDR mode,the higher of 16 bits indicate the CRC of all data.

**5.1.7.37. SD CRC Status Register (Default Value: 0x00000000)**

Offset: 0x0134			Register Name: <b>CRC_STA_REG</b>
Bit	R/W	Default/Hex	Description
31:3	/	/	/
2:0	R	0	CRC_STA CRC Status CRC status from card/eMMC in write operation Positive CRC status token:3'b010 Negative CRC status token:3'b101

**5.1.7.38. SD FIFO Register (Default Value: 0x00000000)**

Offset: 0x0200			Register Name: <b>SD_FIFO_REG</b>
Bit	R/W	Default/Hex	Description
31:0	R/W	0	TX/RX_FIFO Data FIFO

# Chapter 6 Image

This section describes the image of V3s:

- CSI
- MIPI CSI2

## 6.1. CSI

### 6.1.1. Overview

The CSI includes the following feature:

#### CSI

- Support 8/10/12bit yuv422 CMOS sensor interface
- Support 8bit BT656 interface ,support CCIR656 protocol for NTSC and PAL
- Support ITU-R BT1120 protocol for HD-CIF system
- Support 16bit interface with separate syncs
- Support parralel interface still capture resolution up to 5M,video capture resolution up to 1080p@30fps
- Support MIPI interface still capture resolution up to 5M,video capture resolution up to 1080p@30fps
- Support PIP(picture in picture)

#### CCI

- Compatible with i2c transmission in 7 bit slave ID + 1 bit R/W
- Automatic transmission
- 0/8/16/32 bit register address supported
- 8/16/32 bit data supported
- 64bytes-FIFO input CCI data supported
- Synchronized with CSI signal and delay trigger supported
- Repeated transmission with sync signal supported

### 6.1.2. Functionalities Description

#### 6.1.2.1. Block Diagram

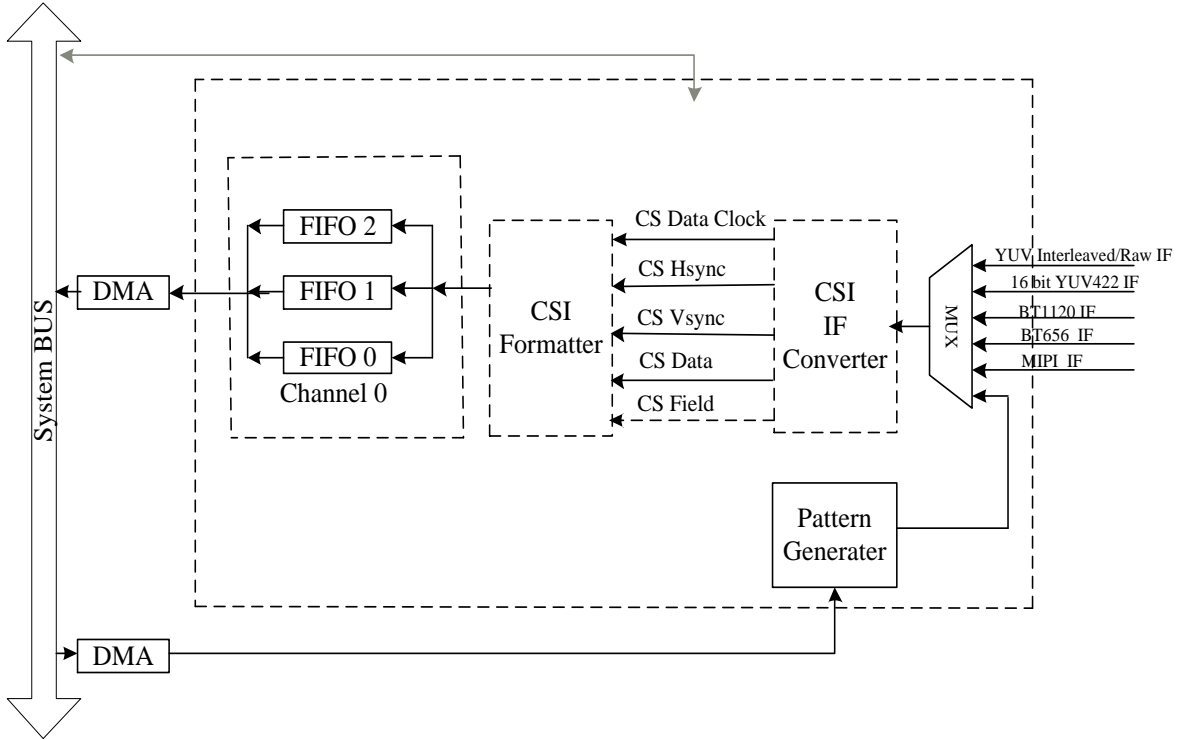

Figure 6-1. CSI Block Diagram

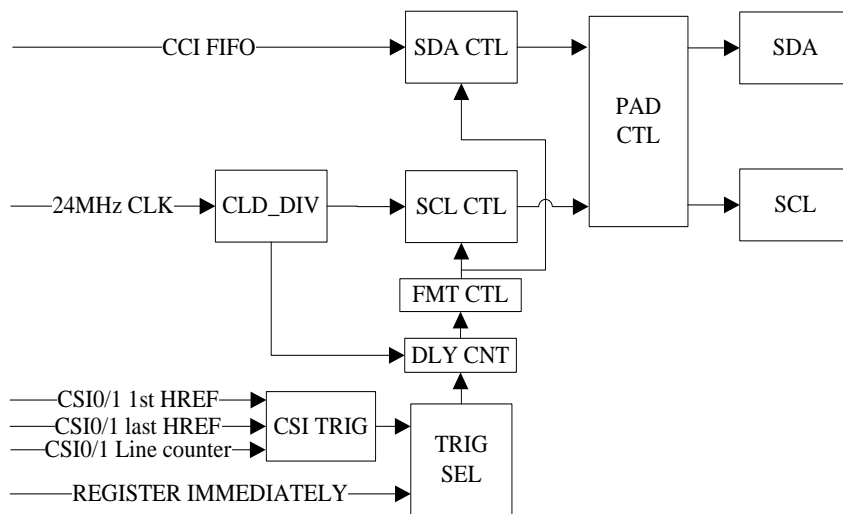

Figure 6-2. CCI Block Diagram

### 6.1.2.2. CSI FIFO Distribution

Interface	YUYV422 Interleaved/RAW			BT656 /BT1120 Interface		MIPI Interface		
	YUV422		Raw	YUV422		YUV422/YUV420		Raw
Output format	Planar	UV combine d/ MB	Raw/RGB /PRGB	Planar	UV combined/ MB	Planar	UV combine d/ MB	Pass-Through /Padding
CH0_FIFO0	Y pixel data	Y pixel data	All pixels data	Y	Y	Y	Y	All pixels data
CH0_FIFO1	Cb (U) pixel data	Cb (U) Cr (V) pixel data	-	Cb (U)	CbCr (UV)	Cb (U)	CbCr (UV)	-
CH0_FIFO2	Cr (V) pixel data	-	-	Cr (V)	-	Cr (V)	-	-

### 6.1.2.3. Pin Mapping

pin	8bit	10bit	12bit	16bit
P0	-	-	D0	Y0
P1	-	-	D1	Y1
P2	-	D0	D2	Y2
P3	-	D1	D3	Y3
P4	D0	D2	D4	Y4
P5	D1	D3	D5	Y5
P6	D2	D4	D6	Y6
P7	D3	D5	D7	Y7
P8	D4	D6	D8	C0
P9	D5	D7	D9	C1
P10	D6	D8	D10	C2
P11	D7	D9	D11	C3
P12	-	-	-	C4
P13	-	-	-	C5
P14	-	-	-	C6
P15	-	-	-	C7

6.1.2.4. Timing

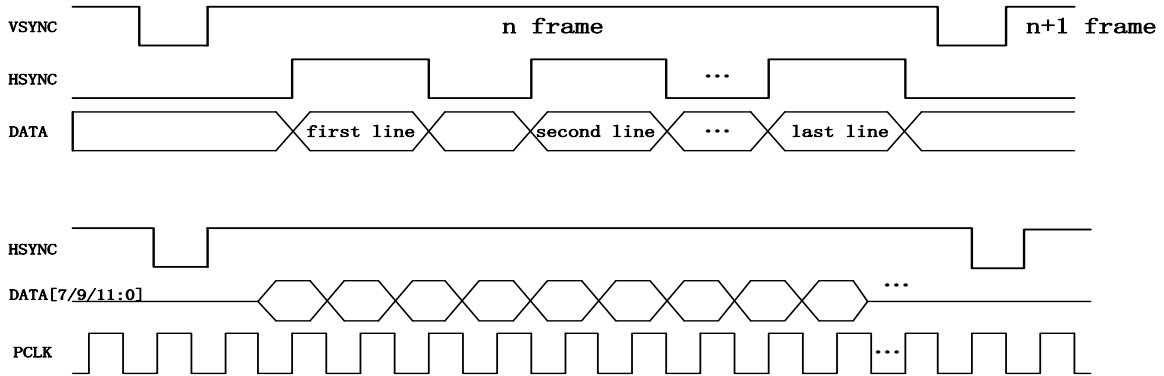

Figure 6-3. 8/10/12-bit CMOS Sensor Interface Timing  
(clock rising edge sample.vsync valid = positive,hsync valid = positive)

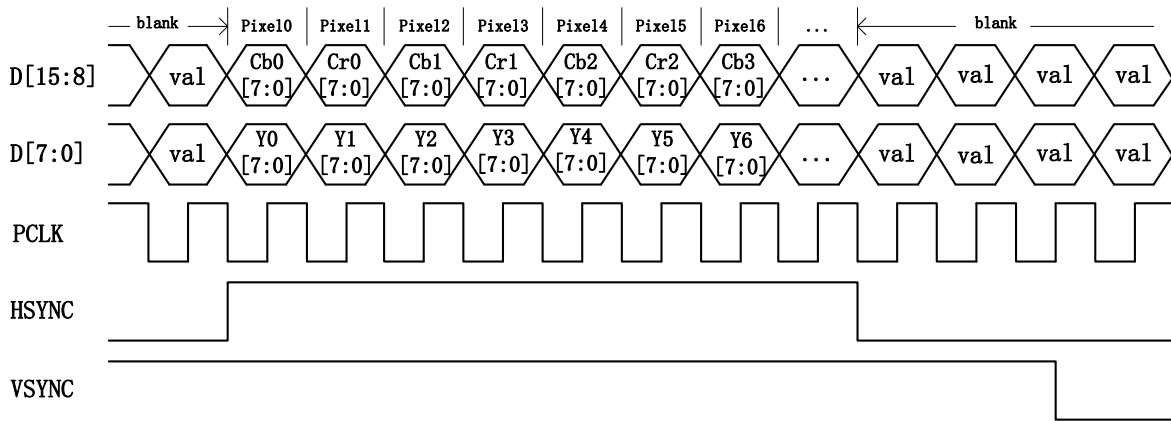

Figure 6-4. 16bit YCbCr4:2:2 with separate syncs Timing  
(clock rising edge sample.vsync valid = positive,hsync valid = positive)

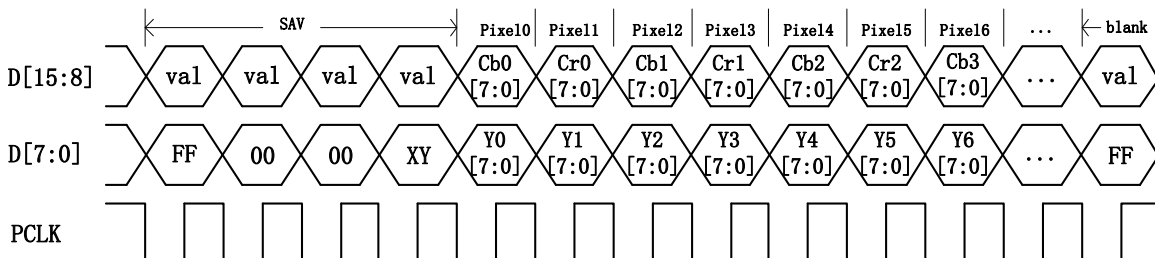

Figure 6-5. 16-bit YCbCr4:2:2 with embedded syncs(BT1120) Timing



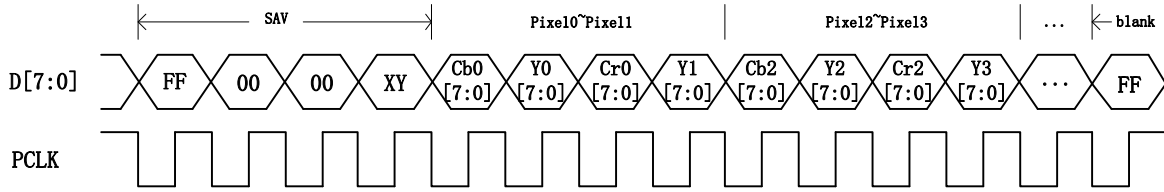

Figure 6-6. 8-bit YCbCr4:2:2 with embedded syncs(BT656) Timing

6.1.2.5. Bit Definition

CCIR656 Header Data Bit Definition:

Data Bit	First Word(0xFF)	Second Word(0x00)	Third Word(0x00)	Fourth Word
CS D[9] (MSB)	1	0	0	1
CS D[8]	1	0	0	F
CS D[7]	1	0	0	V
CS D[6]	1	0	0	H
CS D[5]	1	0	0	P3
CS D[4]	1	0	0	P2
CS D[3]	1	0	0	P1
CS D[2]	1	0	0	P0
CS D[1]	x	x	x	x
CS D[0]	x	x	x	x

Note:

For compatibility with 8-bit interface, CS D[1] and CS D[0] are not defined.

Decode	F	V	H	P3	P2	P1	P0
Field 1 start of active video (SAV)	0	0	0	0	0	0	0
Field 1 end of active video (EAV)	0	0	1	1	1	0	1
Field 1 SAV (digital blanking)	0	1	0	1	0	1	1
Field 1 EAV (digital blanking)	0	1	1	0	1	1	0
Field 2 SAV	1	0	0	0	1	1	1
Field 2 EAV	1	0	1	1	0	1	0
Field 2 SAV (digital blanking)	1	1	0	1	1	0	0
Field 2 EAV (digital blanking)	1	1	1	0	0	0	1

Multi-Channel:

Condition			656FVH Value			SAV-EAV Code						
Field	V-time	H-time	F	V	H	First	Second	Third	Fourth			
									Ch1	Ch2	Ch3	Ch4
EVEN	BLANK	EAV	1	1	1	0xFF	0x00	0x00	0xF0	0xF1	0xF2	0xF3

EVEN	BLANK	SAV	1	1	0	0xFF	0x00	0x00	0xE0	0xE1	0xE2	0xE3
EVEN	BLANK	EAV	1	0	1	0xFF	0x00	0x00	0xD0	0xD1	0xD2	0xD3
EVEN	BLANK	SAV	1	0	0	0xFF	0x00	0x00	0xC0	0xC1	0xC2	0xC3
ODD	BLANK	EAV	0	1	1	0xFF	0x00	0x00	0xB0	0xB1	0xB2	0xB3
ODD	BLANK	SAV	0	1	0	0xFF	0x00	0x00	0xA0	0xA1	0xA2	0xA3
ODD	ACTIVE	EAV	0	0	1	0xFF	0x00	0x00	0x90	0x91	0x92	0x93
ODD	ACTIVE	SAV	0	0	0	0xFF	0x00	0x00	0x80	0x81	0x82	0x83

### 6.1.3. CSI Register list

Module Name	Base Address
CSI0	0x01CB0000
CSI1	0x01CB4000

Register Name	Offset	Register name
CSI_EN_REG	0X0000	CSI Enable register
CSI_IF_CFG_REG	0X0004	CSI Interface Configuration Register
CSI_CAP_REG	0X0008	CSI Capture Register
CSI_SYNC_CNT_REG	0X000C	CSI Synchronization Counter Register
CSI_FIFO_THRS_REG	0X0010	CSI FIFO Threshold Register
CSI_BT656_HEAD_CFG_REG	0X0014	CSI BT656 Header Configuration Register
CSI_PTN_LEN_REG	0X0030	CSI Pattern Generation Length register
CSI_PTN_ADDR_REG	0X0034	CSI Pattern Generation Address register
CSI_VER_REG	0X003C	CSI Version Register
CSI_C0_CFG_REG	0X0044	CSI Channel_0 configuration register
CSI_C0_SCALE_REG	0X004C	CSI Channel_0 scale register
CSI_C0_F0_BUFA_REG	0X0050	CSI Channel_0 FIFO 0 output buffer-A address register
CSI_C0_F1_BUFA_REG	0X0058	CSI Channel_0 FIFO 1 output buffer-A address register
CSI_C0_F2_BUFA_REG	0X0060	CSI Channel_0 FIFO 2 output buffer-A address register
CSI_C0_CAP_STA_REG	0X006C	CSI Channel_0 status register
CSI_C0_INT_EN_REG	0X0070	CSI Channel_0 interrupt enable register
CSI_C0_INT_STA_REG	0X0074	CSI Channel_0 interrupt status register
CSI_C0_FLD1_VSIZE_REG	0X0078	CSI Channel_0 filed1 vertical size register
CSI_C0_HSIZE_REG	0X0080	CSI Channel_0 horizontal size register
CSI_C0_VSIZE_REG	0X0084	CSI Channel_0 vertical size register
CSI_C0_BUF_LEN_REG	0X0088	CSI Channel_0 line buffer length register
CSI_C0_FLIP_SIZE_REG	0X008C	CSI Channel_0 flip size register
CSI_C0_FRM_CLK_CNT_REG	0X0090	CSI Channel_0 frame clock counter register
CSI_C0_ACC_ITNL_CLK_CNT_REG	0X0094	CSI Channel_0 accumulated and internal clock counter register
CSI_C0_FIFO_STAT_REG	0X0098	CSI Channel_0 FIFO Statistic Register
CSI_C0_PCLK_STAT_REG	0X009C	CSI Channel_0 PCLK Statistic Register
CCI_CTRL	0x3000	CCI control register

CCI_CFG	0x3004	CCI transmission config register
CCI_FMT	0x3008	CCI packet format register
CCI_BUS_CTRL	0x300C	CCI bus control register
CCI_INT_CTRL	0x3014	CCI interrupt control register
CCI_LC_TRIG	0x3018	CCI line counter trigger register
CCI_FIFO_ACC	0x3100	CCI FIFO access register

### 6.1.4. CSI Register Description

#### 6.1.4.1. CSI Enable Register (Default Value: 0x00000000)

Offset: 0x0000			Register Name: CSIO_EN_REG
Bit	R/W	Default/Hex	Description
31	/	/	/
30	R/W	0x0	VER_EN CSI Version Register Read Enable: 0: Disable 1: Enable
29:24	/	/	/
23:16	R/W	0x00	PTN_CYCLE Pattern generating cycle counter. The pattern in dram will be generated in cycles of PTN_CYCLE+1.
15:9	/	/	/
8	R/W	0x0	SRAM_PWDN 0: SRAM in normal 1: SRAM in power down
7:5	/	/	/
4	R/W	0x0	PTN_START CSI Pattern Generating Start 0: Finish other: Start Software write this bit to “1” to start pattern generating from DRAM. When finished, the hardware will clear this bit to “0” automatically. Generating cycles depends on PTN_CYCLE.
3	R/W	0	CLK_CNT_SPL Sampling time for clk counter per frame 0: Sampling clock counter every frame done 1: Sampling clock counter every vsync
2	R/W	0	CLK_CNT_EN clk count per frame enable
1	R/W	0	PTN_GEN_EN Pattern Generation Enable

0	R/W	0	CSI_EN Enable 0: Reset and disable the CSI module 1: Enable the CSI module
---	-----	---	---

**6.1.4.2. CSI Interface Configuration Register (Default Value: 0x00000000)**

Offset: 0x0004			Register Name: <b>CSIO_IF_CFG_REG</b>
Bit	R/W	Default/Hex	Description
31:28	/	/	/
27:24	R/W	1	FIELD_DT_PCLK_SHIFT Only for vsync detected field mode,the odd field permitted pclk shift = 4* FIELD_DT_PCLK_SHIFT
23:22	/	/	/
21	R/W	0	SRC_TYPE Source type 0: Progressed 1: Interlaced
20	R/W	0	FPS_DS Fps down sample 0: no down sample 1: 1/2 fps, only receives the first frame every 2 frames
19	R/W	0	FIELD For YUV HV timing, Field polarity 0: negative(field=0 indicate odd, field=1 indicate even ) 1: positive(field=1 indicate odd, field=0 indicate even ) For BT656 timing, Field sequence 0: Normal sequence (field 0 first) 1: Inverse sequence (field 1 first)
18	R/W	1	VREF_POL Vref polarity 0: negative 1: positive This register is not apply to CCIR656 interface.
17	R/W	0	HERF_POL Href polarity 0: negative 1: positive This register is not apply to CCIR656 interface.
16	R/W	1	CLK_POL Data clock type 0: active in rising edge 1: active in falling edge
15:14	R/W	0	Field_DT_MODE ( only valid when CSI_IF is YUV and source type is

			interlaced ) 00:by both field and vsync 01:by field 10:by vsync 11:reserved
13	/	/	/
12:11	R/W	0	SEQ_8PLUS2 When select IF_DATA_WIDTH to be 8+2bit, odd/even pixel byte at CSI-D[11:4] will be rearranged to D[11:2]+2'b0 at the actual csi data bus according to these sequences: 00: 6'bx+D[9:8], D[7:0] 01: D[9:2], 6'bx+D[1:0] 10: D[7:0], D[9:8]+6'bx 11: D[7:0], 6'bx+D[9:8]
10:8	R/W	0	IF_DATA_WIDTH 000: 8 bit data bus 001: 10 bit data bus 010: 12 bit data bus 011: 8+2bit data bus 100:2x8bit data bus Other:reserved
7	R/W	0	MIPI_IF MIPI Interface Enable: 0: CSI 1: MIPI
6:5	/	/	/
4:0	R/W	0	CSI_IF YUV: 00000: YUYV422 Interleaved or RAW (All data in one data bus) 00001: YUV422 UV Combined (16 bit interface with seperate syncs)  CCIR656: 00100: YUYV422 Interleaved or RAW (All data in one data bus) 00101:YUV422 UV Combined (16 bit inrerface with embedded syncs,BT1120 ) Others: Reserved

#### 6.1.4.3. CSI Capture Register (Default Value: 0x00000000)

Offset: 0x0008			Register Name: <b>CSIO_CAP_REG</b>
Bit	R/W	Default/Hex	Description
31:6	/	/	/
5:2	R/W	0x0	CH0_CAP_MASK Vsync number masked before capture.

1	R/W	0x0	<p>CH0_VCAP_ON</p> <p>Video capture control: Capture the video image data stream on channel 0.</p> <p>0: Disable video capture</p> <p>If video capture is in progress, the CSI stops capturing image data at the end of the current frame, and all of the current frame data is wrote to output FIFO.</p> <p>1: Enable video capture</p> <p>The CSI starts capturing image data at the start of the next frame.</p>
0	R/W	0x0	<p>CH0_SCAP_ON</p> <p>Still capture control: Capture a single still image frame on channel 0.</p> <p>0: Disable still capture.</p> <p>1: Enable still capture</p> <p>The CSI module starts capturing image data at the start of the next frame.</p> <p>The CSI module captures only one frame of image data. This bit is self clearing and always reads as a 0.</p>

#### 6.1.4.4. CSI Synchronization Counter Register (Default Value: 0x00000000)

Offset: 0x000C			Register Name: <b>CSI0_SYNC_CNT_REG</b>
Bit	R/W	Default/Hex	Description
31:24	/	/	/
23:0	R	0	<p>SYNC_CNT</p> <p>The counter value between vsync of CSI0 channel 0 and vsync of CSI1 channel 0 , using 24MHz.</p>

#### 6.1.4.5. CSI FIFO Threshold Register (Default Value: 0x040f0400)

Offset: 0x0010			Register Name: <b>CSI0_FIFO_THRS_REG</b>
Bit	R/W	Default/Hex	Description
31:29	/	/	/
28:26	R/W	0x1	<p>FIFO_NEARLY_FULL_TH</p> <p>The threshold of FIFO being nearly full. Indicates that the ISP should stop writing. Only valid when ISP is enabled.</p> <p>0~7:</p> <p>The smaller the value, the flag of FIFO being nearly full is easier to reach.</p>
25:24	R/W	0x0	<p>PTN_GEN_CLK_DIV</p> <p>Packet generator clock divider</p>
23:16	R/W	0x0f	<p>PTN_GEN_DLY</p> <p>Clocks delayed before pattern generating start.</p>
15:12	/	/	/
11:00	R/W	0x400	<p>FIFO_THRS</p> <p>When CSI0 FIFO occupied memory exceed the threshold, dram frequency</p>

			can not change.
--	--	--	-----------------

**6.1.4.6. CSI BT656 Header Configuration Register (Default Value: 0x03020100)**

Offset: 0x0014			Register Name: <b>CSIO_BT656_HEAD_CFG_REG</b>
Bit	R/W	Default/Hex	Description
31:28	/	/	/
27:24	R/W	0x3	CH3_ID The low 4bit of BT656 header for channel 3 Only valid in BT656 multi-channel mode
23:20	/	/	/
19:16	R/W	0x2	CH2_ID The low 4bit of BT656 header for channel 2 Only valid in BT656 multi-channel mode
15:12	/	/	/
11:08	R/W	0x1	CH1_ID The low 4bit of BT656 header for channel 1 Only valid in BT656 multi-channel mode
07:04	/	/	/
03:00	R/W	0x0	CH0_ID The low 4bit of BT656 header for channel 0 Only valid in BT656 multi-channel mode

**6.1.4.7. CSI Pattern Generation Length Register (Default Value: 0x00000000)**

Offset: 0x0030			Register Name: <b>CSIO_PTN_LEN_REG</b>
Bit	R/W	Default/Hex	Description
31:0	R/W	0x0	PTN_LEN The pattern length in byte when generating pattern.

**6.1.4.8. CSI Pattern Generation Address Register (Default Value: 0x00000000)**

Offset: 0x0034			Register Name: <b>CSIO_PTN_ADDR_REG</b>
Bit	R/W	Default/Hex	Description
31:0	R/W	0x0	PTN_ADDR The pattern DRAM address when generating pattern.

**6.1.4.9. CSI Version Register (Default Value: 0x00000000)**

Offset: 0x003C			Register Name: <b>CSIO_VER_REG</b>
Bit	R/W	Default/Hex	Description
31:0	R	/	VER Version of hardware circuit. Only can be read when version register read enable is on.

**6.1.4.10. CSI Channel\_0 configuration Register (Default Value: 0x00300200)**

Offset: 0x0044			Register Name: <b>CSIO_CO_CFG_REG</b>
Bit	R/W	Default/Hex	Description
31:24	R/W	0	PAD_VAL Padding value when OUTPUT_FMT is prgb888 0x00~0xff
23:20	R/W	3	INPUT_FMT Input data format 0000: RAW stream 0001: reserved 0010: reserved 0011: YUV422 0100: YUV420 Others: reserved
19:16	R/W	0	OUTPUT_FMT Output data format When the input format is set RAW stream 0000: field-raw-8 0001: field-raw-10 0010: field-raw-12 0011: reserved 0100: field-rgb565 0101: field-rgb888 0110: field-prgb888 1000: frame-raw-8 1001: frame-raw-10 1010: frame-raw-12 1011: reserved 1100: frame-rgb565 1101: frame-rgb888 1110: frame-prgb888  When the input format is set YUV422 0000: field planar YCbCr 422



			<p>0001: field planar YCbCr 420  0010: frame planar YCbCr 420  0011: frame planar YCbCr 422  0100: field planar YCbCr 422 UV combined  0101: field planar YCbCr 420 UV combined  0110: frame planar YCbCr 420 UV combined  0111: frame planar YCbCr 422 UV combined  1000: field MB YCbCr 422  1001: field MB YCbCr 420  1010: frame MB YCbCr 420  1011: frame MB YCbCr 422  1100: field planar YCbCr 422 10bit UV combined  1101: field planar YCbCr 420 10bit UV combined  1110: Reserved  1111: Reserved</p> <p>When the input format is set YUV420  0000: Reserved  0001: field planar YCbCr 420  0010: frame planar YCbCr 420  0011: Reserved  0100: Reserved  0101: field planar YCbCr 420 UV combined  0110: frame planar YCbCr 420 UV combined  0111: Reserved  1000: Reserved  1001: field MB YCbCr 420  1010: frame MB YCbCr 420  1011: Reserved  1100: Reserved  1101: field planar YCbCr 420 10bit UV combined  1110: Reserved  1111: Reserved</p> <p>Others: reserved</p>
15:14	/	/	/
13	R/W	0	VFLIP_EN Vertical flip enable When enabled, the received data will be arranged in vertical flip. 0:Disable 1:Enable
12	R/W	0	HFLIP_EN Horizontal flip enable When enabled, the received data will be arranged in horizontal flip. 0:Disable

			1:Enable
11:10	R/W	0	FIELD_SEL Field selection. 00: capturing with field 1. 01: capturing with field 2. 10: capturing with either field. 11: reserved
09:08	R/W	2	INPUT_SEQ Input data sequence, only valid for YUV422 and YUV420 input format. All data interleaved in one channel: 00: YUYV 01: YVYU 10: UYVY 11: VYUY Y and UV in separated channel: x0: UV x1: VU
07:02	/	/	/
01:00	R/W	0	MIN_SDR_WR_SIZE Minimum size of SDRAM block write 0: 256 bytes (if hflip is enable, always select 256 bytes) 1: 512 bytes 2: 1k bytes 3: 2k bytes

#### 6.1.4.11. CSI Channel\_0 scale Register (Default Value: 0x00000000)

Offset: 0x004C			Register Name: <b>CSI0_CO_SCALE_REG</b>
Bit	R/W	Default/Hex	Description
31:01	/	/	/
00	R/W	0	QUART_EN When this bit is set to 1, input image will be decimated to quarter size. All input format are supported.

#### 6.1.4.12. CSI Channel\_0 FIFO 0 output buffer-A address Register (Default Value: 0x00000000)

Offset: 0x0050			Register Name: <b>CSI0_CO_F0_BUFA_REG</b>
Bit	R/W	Default/Hex	Description
31:00	R/W	0	COFO_BUFA FIFO 0 output buffer-A address

**6.1.4.13. CSI Channel\_0 FIFO 1 output buffer-A address Register (Default Value: 0x00000000)**

Offset: 0x0058			Register Name: <b>CSI0_CO_F1_BUFA_REG</b>
Bit	R/W	Default/Hex	Description
31:00	R/W	0	COF1_BUFA FIFO 1 output buffer-A address

**6.1.4.14. CSI Channel\_0 FIFO 2 output buffer-A address Register (Default Value: 0x00000000)**

Offset: 0x0060			Register Name: <b>CSI0_CO_F2_BUFA_REG</b>
Bit	R/W	Default/Hex	Description
31:00	R/W	0	COF2_BUFA FIFO 2 output buffer-A address

**6.1.4.15. CSI Channel\_0 status Register (Default Value: 0x00000000)**

Offset: 0x006C			Register Name: <b>CSI0_CO_CAP_STA_REG</b>
Bit	R/W	Default/Hex	Description
31:03	/	/	/
02	R	0	FIELD_STA The status of the received field 0: Field 0 1: Field 1
01	R	0	VCAP_STA Video capture in progress Indicates the CSI is capturing video image data (multiple frames). The bit is set at the start of the first frame after enabling video capture. When software disables video capture, it clears itself after the last pixel of the current frame is captured.
00	R	0	SCAP_STA Still capture in progress Indicates the CSI is capturing still image data (single frame). The bit is set at the start of the first frame after enabling still frame capture. It clears itself after the last pixel of the first frame is captured. For CCIR656 interface, if the output format is frame planar YCbCr 420 mode, the frame end means the field2 end, the other frame end means filed end.

**6.1.4.16. CSI Channel\_0 interrupt enable Register (Default Value: 0x00000000)**

Offset: 0x0070			Register Name: <b>CSI0_CO_INT_EN_REG</b>
----------------	--	--	--

Bit	R/W	Default/Hex	Description
31:08	/	/	/
07	R/W	0	VS_INT_EN vsync flag The bit is set when vsync come. And at this time load the buffer address for the coming frame. So after this irq come, change the buffer address could only effect next frame
06	R/W	0	HB_OF_INT_EN Hblank FIFO overflow The bit is set when 3 FIFOs still overflow after the hblank.
05	R/W	0	MUL_ERR_INT_EN Multi-channel writing error Indicates error has been detected for writing data to a wrong channel.
04	R/W	0	FIFO2_OF_INT_EN FIFO 2 overflow The bit is set when the FIFO 2 become overflow.
03	R/W	0	FIFO1_OF_INT_EN FIFO 1 overflow The bit is set when the FIFO 1 become overflow.
02	R/W	0	FIFO0_OF_INT_EN FIFO 0 overflow The bit is set when the FIFO 0 become overflow.
01	R/W	0	FD_INT_EN Frame done Indicates the CSI has finished capturing an image frame. Applies to video capture mode. The bit is set after each completed frame capturing data is writed to buffer as long as video capture remains enabled.
00	R/W	0	CD_INT_EN Capture done Indicates the CSI has completed capturing the image data. For still capture, the bit is set when one frame data has been wrote to buffer. For video capture, the bit is set when the last frame has been wrote to buffer after video capture has been disabled. For CCIR656 interface, if the output format is frame planar YCbCr 420 mode, the frame end means the field2 end, the other frame end means field end.

#### 6.1.4.17. CSI Channel\_0 interrupt status Register (Default Value: 0x00000000)

Offset: 0x0074			Register Name: <b>CSIO_CO_INT_STA_REG</b>
Bit	R/W	Default/Hex	Description
31:08	/	/	/
07	R/W	0	VS_PD vsync flag

06	R/W	0	HB_OF_PD Hblank FIFO overflow
05	R/W	0	MUL_ERR_PD Multi-channel writing error
04	R/W	0	FIFO2_OF_PD FIFO 2 overflow
03	R/W	0	FIFO1_OF_PD FIFO 1 overflow
02	R/W	0	FIFO0_OF_PD FIFO 0 overflow
01	R/W	0	FD_PD Frame done
00	R/W	0	CD_PD Capture done

**6.1.4.18. CSI Channel\_0 filed1 vertical size Register (Default Value: 0x01E00000)**

Offset: 0x0078			Register Name: CSIO_CO_FLD1_VSIZE_REG
Bit	R/W	Default/Hex	Description
31:29	/	/	/
28:16	R/W	1E0	VER_LEN Valid line number of filed1,only valid when CSI_IF is YUV and source type is interlaced.
15:13	/	/	/
12:00	R/W	0	VER_START Vertical line start of filed1. data is valid from this line,only valid when CSI_IF is YUV and source type is interlaced.

**6.1.4.19. CSI Channel\_0 horizontal size Register (Default Value: 0x05000000)**

Offset: 0x0080			Register Name: CSIO_CO_INT_STA_REG
Bit	R/W	Default/Hex	Description
31:29	/	/	/
28:16	R/W	500	HOR_LEN Horizontal pixel unit length. Valid pixel of a line.
15:13	/	/	/
12:00	R/W	0	HOR_START Horizontal pixel unit start. Pixel is valid from this pixel.

**6.1.4.20. CSI Channel\_0 vertical size Register (Default Value: 0x01E00000)**

Offset: 0x0084			Register Name: CSIO_CO_VSIZE_REG
Bit	R/W	Default/Hex	Description
31:29	/	/	/
28:16	R/W	1E0	VER_LEN Vertical line length. Valid line number of a frame. Stand for line number of field0 when CSI_IF is YUV and source type is interlaced.
15:13	/	/	/
12:00	R/W	0	VER_START Vertical line start. data is valid from this line. Stand for start line of field0 when CSI_IF is YUV and source type is interlaced.

**6.1.4.21. CSI Channel\_0 buffer length Register (Default Value: 0x01400280)**

Offset: 0x0088			Register Name: CSIO_CO_BUF_LEN_REG
Bit	R/W	Default/Hex	Description
31:30	/	/	/
29:16	R/W	140	BUF_LEN_C Buffer length of chroma C in a line. Unit is byte.
15:14	/	/	/
13:00	R/W	280	BUF_LEN Buffer length of luminance Y in a line. Unit is byte.

**6.1.4.22. CSI Channel\_0 flip size Register (Default Value: 0x01E00280)**

Offset: 0x008C			Register Name: CSIO_CO_FLIP_SIZE_REG
Bit	R/W	Default/Hex	Description
31:29	/	/	/
28:16	R/W	1E0	VER_LEN Vertical line number when in vflip mode.
15:13	/	/	/
12:00	R/W	280	VALID_LEN Valid components of a line when in flip mode.

**6.1.4.23. CSI Channel\_0 frame clock counter Register (Default Value: 0x00000000)**

Offset: 0x0090			Register Name: CSIO_CO_FRM_CLK_CNT_REG
Bit	R/W	Default/Hex	Description
31:24	/	/	/

23:00	R	0	<p>FRM_CLK_CNT</p> <p>Counter value between every frame. For instant hardware frame rate statics.</p> <p>The internal counter is added by one every 24MHz clock cycle. When frame done or vsync comes, the internal counter value is sampled to FRM_CLK_CNT, and cleared to 0.</p>
-------	---	---	--

**6.1.4.24. CSI Channel\_0 accumulated and internal clock counter Register (Default Value: 0x00000000)**

Offset: 0x0094			Register Name: <b>CSIO_CO_ACC_ITNL_CLK_CNT_REG</b>
Bit	R/W	Default/Hex	Description
31:24	R	0	<p>ACC_CLK_CNT</p> <p>The accumulated value of FRM_CLK_CNT for software frame rate statics. Every interrupt of frame done, the software check this accumulated value and clear it to 0. If the ACC_CLK_CNT is larger than 1, the software has lost frame.</p> <p>When frame done or vsync comes, ACC_CLK_CNT = ACC_CLK_CNT + 1, and cleared to 0 when writing 0 to this register.</p>
23:00	R	0	<p>ITNL_CLK_CNT</p> <p>The instant value of internal frame clock counter.</p> <p>When frame done interrupt comes, the software can query this counter for judging whether it is the time for updating the double buffer address registers.</p>

**6.1.4.25. CSI Channel\_0 FIFO Statistic Register (Default Value: 0x00000000)**

Offset: 0x0098			Register Name: <b>CSIO_CO_FIFO_STAT_REG</b>
Bit	R/W	Default/Hex	Description
31:12	/	/	/
11:00	R	0	<p>FIFO_FRM_MAX</p> <p>Indicates the maximum depth of FIFO being occupied for whole frame. Update at every vsync or framedone.</p>

**6.1.4.26. CSI Channel\_0 PCLK Statistic Register (Default Value: 0x00007FFF)**

Offset: 0x009C			Register Name: <b>CSIO_CO_PCLK_STAT_REG</b>
Bit	R/W	Default/Hex	Description
31	/	/	/
30:16	R	0	<p>PCLK_CNT_LINE_MAX</p> <p>Indicates maximum pixel clock counter value for each line. Update at every vsync or framedone.</p>

15	/	/	/
14:00	R	0x7fff	PCLK_CNT_LINE_MIN Indicates minimum pixel clock counter value for each line. Update at every vsync or framedone.

**6.1.4.27. CCI Control Register (Default Value: 0x00000000)**

Offset: 0x3000			Register Name: <b>CCI_CTRL_REG</b>
Bit	R/W	Default/Hex	Description
31	R/W	0	SINGLE_TRAN 0: Transmission idle 1: Start single transmission Automatically cleared to '0' when finished. Abort current transmission immediately if changing from '1' to '0'. If slave not respond for the expected status over the time defined by TIMEOUT, current transmission will stop. PACKET_CNT will return the sequence number when transmission fail. All format setting and data will be loaded from registers and FIFO when transmission start.
30	R/W	0	REPEAT_TRAN 0: transmission idle 1: repeated transmission When this bit is set to 1, transmission repeats when trigger signal (such as VSYNC/ VCAP done ) repeats. If changing this bit from '1' to '0' during transmission, the current transmission will be guaranteed then stop.
29	R/W	0	RESTART_MODE 0: RESTART 1: STOP+START Define the CCI action after sending register address.
28	R/W	0	READ_TRAN_MODE 0: send slave_id+W 1: do not send slave_id+W <b>Setting this bit to 1 if reading from a slave which register width is equal to 0.</b>
27:24	R	0	TRAN_RESULT 000: OK 001: FAIL Other: Reserved
23:16	R	/	CCI_STA 0x00: bus error 0x08: START condition transmitted 0x10: Repeated START condition transmitted 0x18: Address + Write bit transmitted, ACK received 0x20: Address + Write bit transmitted, ACK not received



			0x28: Data byte transmitted in master mode, ACK received 0x30: Data byte transmitted in master mode, ACK not received 0x38: Arbitration lost in address or data byte 0x40: Address + Read bit transmitted, ACK received 0x48: Address + Read bit transmitted, ACK not received 0x50: Data byte received in master mode, ACK received 0x58: Data byte received in master mode, ACK not received 0x01: Timeout when sending 9th SCL clk Other: Reserved
15:2	/	/	/
1	R/W	0	SOFT_RESET 0: normal 1: reset
0	R/W	0	CCI_EN 0: Module disable 1: Module enable

**6.1.4.28. CCI Transmission Configuration Register (Default Value: 0x1000000)**

Offset: 0x3004			Register Name: CCI_CFG_REG
Bit	R/W	Default/Hex	Description
31:24	R/W	0x10	TIMEOUT_N When sending the 9th clock, assert fail signal when slave device did not response after N*FSCL cycles. And software must do a reset to CCI module and send a stop condition to slave.
23:16	R/W	0x00	INTERVAL Define the interval between each packet in 40*FSCL cycles. 0~255
15	R/W	0	PACKET_MODE Select where to load slave id / data width 0: Compact mode 1: Complete mode In compact mode, slave id/register width / data width will be loaded from CCI_FMT register, only address and data read from memory. In complete mode, they will be loaded from packet memory.
14:7	/	/	/
6:4	R/W	0	TRIG_MODE Transmit mode: 000: Immediately, no trigger 001: Reserved 010: CSIO int trigger 011: CSI1 int trigger
3:0	R/W	0	CSI_TRIG CSI Int trig signal select: 0000: First HREF start

			0001: Last HREF done 0010: Line counter trigger other: Reserved
--	--	--	---

**6.1.4.29. CCI Packet Format Register (Default Value: 0x00110001)**

Offset: 0x3008			Register Name: <b>CCI_FMT_REG</b>
Bit	R/W	Default/Hex	Description
31:25	R/W	0	SLV_ID 7bit address
24	R/W	0	CMD 0: write 1: read
23:20	R/W	1	ADDR_BYTE How many bytes be sent as address 0~15
19:16	R/W	1	DATA_BYTE How many bytes be sent/received as data 1~15 Normally use ADDR_DATA with 0_2, 1_1, 1_2, 2_1, 2_2 access mode. If DATA bytes is 0, transmission will not start. In complete mode, the ADDR_BYTE and DATA_BYTE is defined in a byte's high/low 4bit.
15:0	R/W	1	PACKET_CNT FIFO data be transmitted as PACKET_CNT packets in current format. Total bytes not exceed 32bytes.

**6.1.4.30. CCI Bus Control Register (Default Value: 0x00002500)**

Offset: 0x300C			Register Name: <b>CCI_BUS_REG</b>
Bit	R/W	Default/Hex	Description
31:16	R/W	0	DLY_CYC 0~65535 FSCL cycles between each transmission
15	R/W	0	DLY_TRIG 0: disable 1: execute transmission after internal counter delay when triggered
14:12	R/W	0x2	CLK_N CCI bus sampling clock $F_0=24\text{MHz}/2^{\text{CLK\_N}}$
11:8	R/W	0x5	CLK_M CCI output SCL frequency is $\text{FSCL}=F_1/10=(F_0/(\text{CLK\_M}+1))/10$
7	R	/	SCL_STA SCL current status
6	R	/	SDA_STA

			SDA current status
5	R/W	0	SCL_PEN SCL PAD enable
4	R/W	0	SDA_PEN SDA PAD enable
3	R/W	0	SCL_MOV SCL manual output value
2	R/W	0	SDA_MOV SDA manual output value
1	R/W	0	SCL_MOE SCL manual output en
0	R/W	0	SDA_MOE SDA manual output en

**6.1.4.31. CCI Interrupt Control Register (Default Value: 0x00000000)**

Offset: 0x3014			Register Name: <b>CCI_INT_CTRL_REG</b>
Bit	R/W	Default/Hex	Description
31:18	/	/	/
17	R/W	0	S_TRAN_ERR_INT_EN
16	R/W	0	S_TRAN_COM_INT_EN
15:2	/	/	/
1	R/W	0	S_TRAN_ERR_PD
0	R/W	0	S_TRAN_COM_PD

**6.1.4.32. CCI Line Counter Trigger Control Register (Default Value: 0x00000000)**

Offset: 0x3018			Register Name: <b>CCI_LC_REG</b>
Bit	R/W	Default/Hex	Description
31:13	/	/	/
12:0	R/W	0	LN_CNT 0~8191: line counter send trigger when 1st~8192th line is received.

**6.1.4.33. CCI FIFO Access Register (Default Value: 0x00000000)**

Offset: 0x3100~0x313f			Register Name: <b>CCI_FIFO_ACC_REG</b>
Bit	R/W	Default/Hex	Description
31:0	R/W	0	DATA_FIFO From 0x100 to 0x13f, CCI data fifo is 64bytes, used in fifo input mode. CCI transmission read/write data from/to fifo in byte.

## 6.2. MIPI CSI2

### 6.2.1. Overview

The MIPI CSI2 includes the following feature:

- MIPI CSI-2 Receiver as a slave without CCI (Camera Control Interface)
- Unidirectional Clock and Data Lane
- Standard CSI-2 protocol with ECC and CRC
- Supports format: YUV422-8bit/10bit, YUV420-8bit/10bit, RAW-8, RAW-10, RAW-12, RGB888, RGB565
- D-PHY with HS-RX, LP-TX, LP-RX
- 1,2 Data Lanes Configuration and up to 1Gbps per Lane in HS Transmission
- Maximum to 720p@30fps or 1080p@15fps with one data Lane in one channel
- Maximum to 1080p@30fps or 5M@15fps with two data Lanes in one channel
- Maximum to 2 data type interleaving in one channel

# Chapter 7 Display

This chapter describes the V3s display system from two aspects:

- Display Engine 2.0
- TCON

The following figure shows the block diagram of display system:

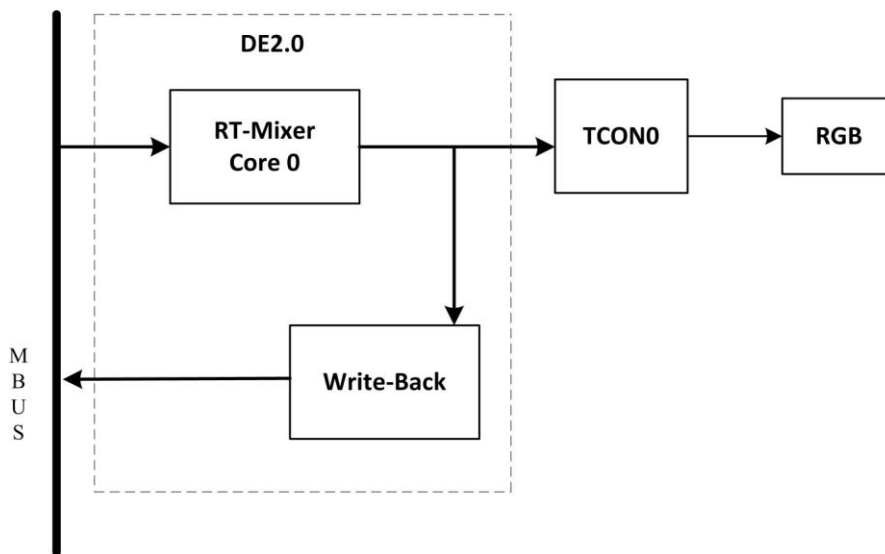

Figure 7-1. Display System Block Diagram

## 7.1. Display Engine 2.0

### 7.1.1. Overview

- Output size up to 1024x1024
- Support three alpha blending channel for main display
- Support four overlay layers in each channel, and has a independent scale
- Support potter-duff compatible blending operation
- Support input format YUV422/YUV420/YUV411/ARGB8888/XRGB8888/RGB888/ARGB4444/ARGB1555/RGB565

## 7.2. TCON

### 7.2.1. Overview

- Support RGB interface with DE/SYNC mode, up to 1024x768@60fps
- Support serial RGB/dummy RGB/CCIR656 interface, up to 800x480@60fps
- Support i80 interface with 18/16/9/8 bit, support TE, up to 1024x768@60fps
- Support pixel format: RGB888, RGB666 and RGB565
- Dither function from RGB666/RGB565 to RGB888
- Gamma correction with R/G/B channel independence
- 4 interrupts for programmer LCD output

### 7.2.2. Block Diagram

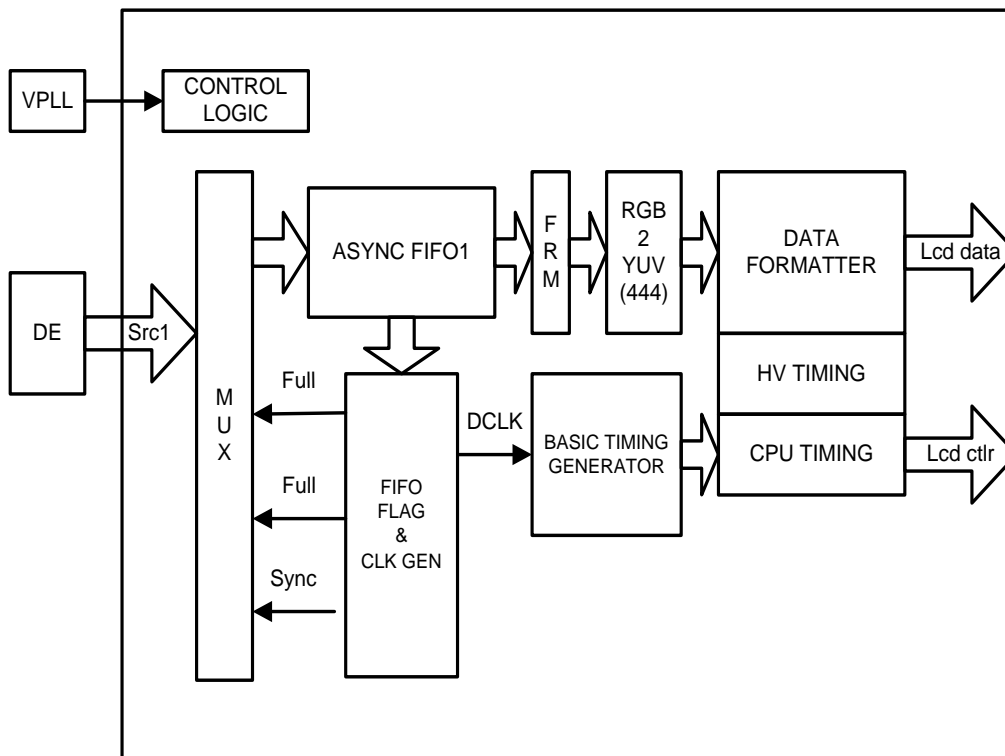

Figure 7-2. TCON Block Diagram

### 7.2.3. Functionalities Description

#### 7.2.3.1. Panel Interface

##### HV\_I/F(Sync+DE mode)

HV I/F is also known as Sync + DE mode, which is widely used in TFT LCD module for PMP/MP4 applications. Its signals are define as:

Main Signal	I/O type	Definition And Description
Vsync	O	Vertical sync, indicates one new frame
Hsync	O	Horizontal sync, indicate one new scan line
DCLK	O	Dot clock, pixel data are sync by this clock
LDE	O	LCD data enable
LD[23..0]	O	18Bit RGB/YUV output from input FIFO for panel

HV control signals are active low.

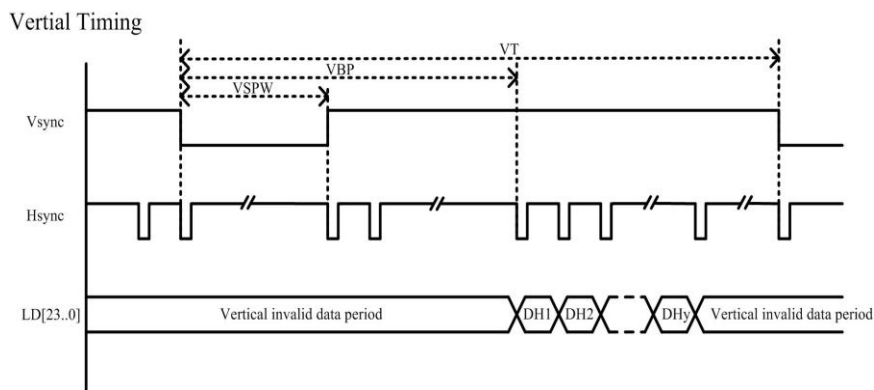

Figure 7-3. Panel Interface Odd/Even Field Vertical Timing

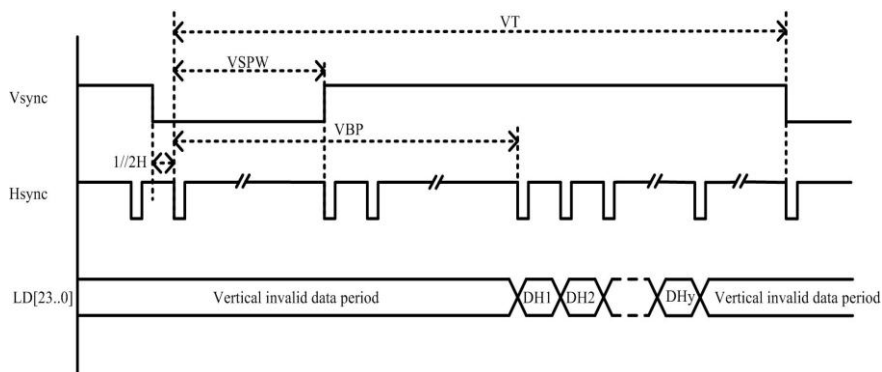

Figure 7-4. Panel Interface Even Field Vertical Timing

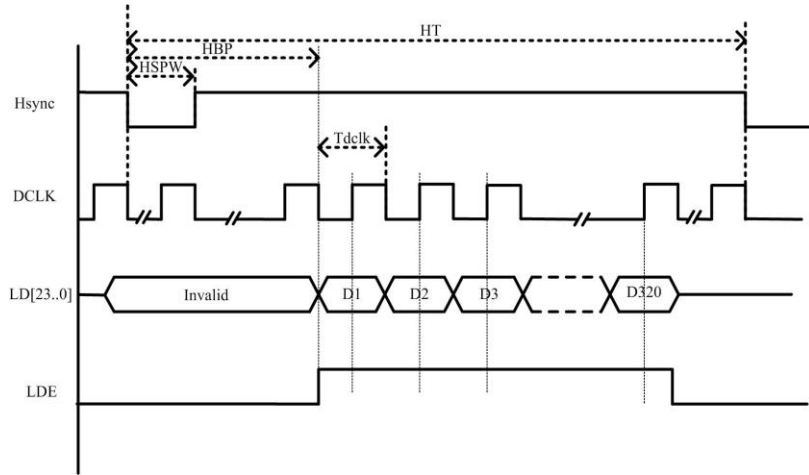

Figure 7-5. Parallel Mode Horizontal Timing

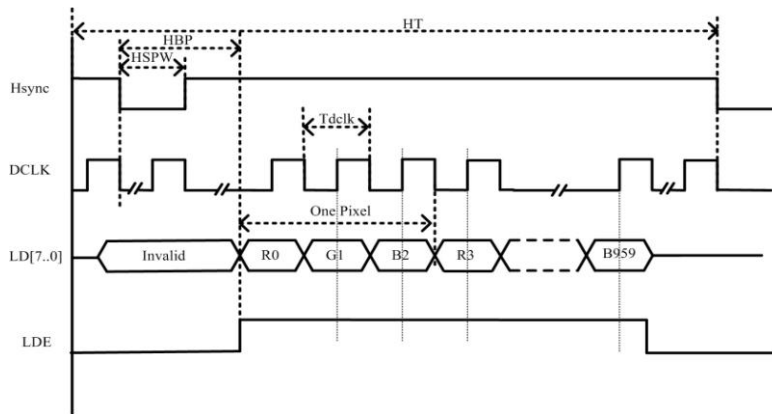

Figure 7-6. Serial Mode Horizontal Timing

**CCIR output SAV/EAV sync signal**

When in HV serial YUV output mode, it's timing is CCIR656/601 compatible. SAV add right before active area every line; EAV add right after active area every line.

It logic are:

F = "0" for Field 1 F = "1" for Field 2

V = "1" during vertical blanking

H = "0" at SAV H = "1" at EAV

P3-P0 = protection bits

$$P3 = V \oplus H$$

$$P2 = F \oplus H$$

$$P1 = F \oplus V$$

$$P0 = F \oplus V \oplus H$$

Where  $\oplus$  represents the exclusive-OR function

The 4 byte SAV/EAV sequences are:

	8-bit Data	10-bit Data
--	------------	-------------



	D9 (MSB)	D8	D7	D6	D5	D4	D3	D2	D1	D0
preamble	1	1	1	1	1	1	1	1	1	1
	0	0	0	0	0	0	0	0	0	0
	0	0	0	0	0	0	0	0	0	0
Status word	1	F	V	H	P3	P2	P1	P0	0	0

**CPU\_I/F**

CPU I/F LCD panel is most common interface for small size, low resolution LCD panels.

CPU control signals are active low.

Main Signal	I/O type	Definition And Description
CS	O	Chip select, active low
WR	O	Write strobe, active low
RD	O	Read strobe, active low
A1	O	Address bit, controlled by "LCD_CPU I/F" BIT26/25
D[23..0]	I/O	Digital RGB output signal

The following figure relationship between basic timing and CPU timing. WR is 180 degree delay of DCLK; CS is active when pixel data are valid; RD is always set to 1; A1 are set by "Lcd\_CPU I/F".

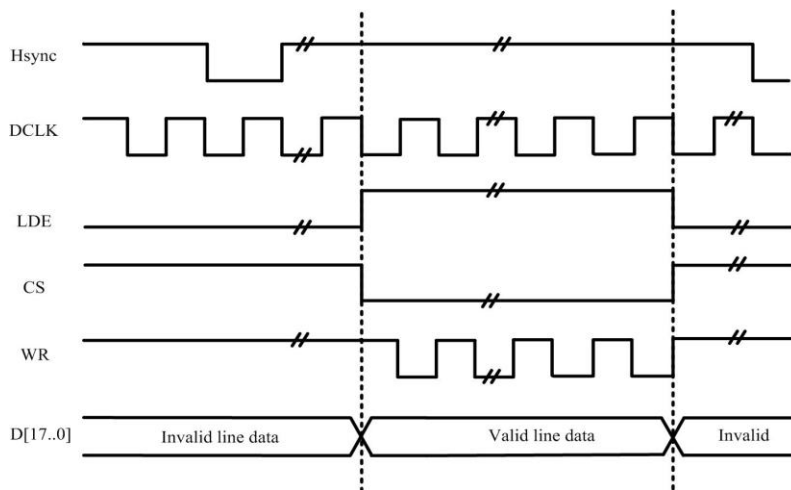

Figure 7-7. Lcd\_CPU I/F Timing

When CPU I/F is in IDLE state, it can generate WR/RD timing by setting "Lcd\_CPU I/F". CS strobe is one DCLK width, WR/RD strobe is half DCLK width.

**7.2.3.2. RGB gamma correction**

Function: This module correct the RGB input data of DE0 .

A 256\*8\*3 Byte register file is used to store the gamma table. The following is the layout:

Offset	Value
0x400, 0x401, 0x402	{ B0[7:0], G0[7:0], R0[7:0] }
0x404,	{ B1[7:0], G1[7:0], R1[7:0] }
.....	.....
0x4FC	{ B255[7:0], G255[7:0], R255[7:0] }

**7.2.3.3. CEU module**

Function: This module enhance color data from DE0 .

$$R' = R_r * R + R_g * G + R_b * B + R_c$$

$$G' = G_r * R + G_g * G + G_b * B + G_c$$

$$B' = B_r * R + B_g * G + B_b * B + B_c$$

Note:

$$R_r, R_g, R_b, G_r, G_g, G_b, B_r, B_g, B_b \quad s13 (-16,16)$$

$$R_c, G_c, B_c \quad s19 (-16384, 16384)$$

$$R, G, B \quad u8 [0-255]$$

R' have the range of [Rmin ,Rmax]

G' have the range of [Rmin ,Rmax]

B' have the range of [Rmin ,Rmax]

**7.2.3.4. CMAP module**

Function: This module map color data from DE0

Every 4 input pixels as an unit. an unit is divided into 12 bytes. Output byte can select one of those 12 bytes. Note that even line and odd line can be different, and output can be 12 bytes(4 pixels) or reduce to 6 bytes(2 pixels).

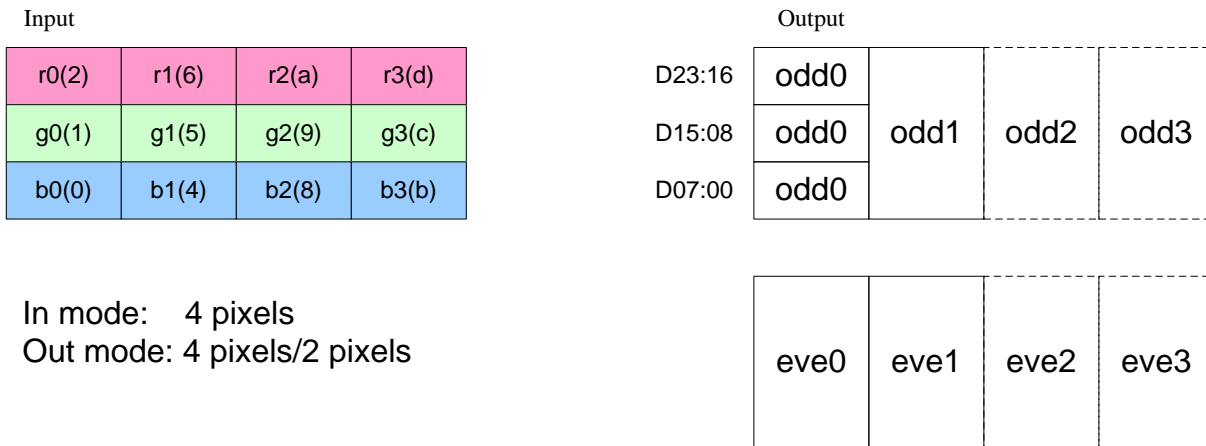

### 7.2.4. TCON Module Register List

Module Name	Base Address
TCON	0x01C0C000

Register Name	Offset	Description
TCON_GCTL_REG	0x000	TCON global control register
TCON_GINT0_REG	0x004	TCON global interrupt register0
TCON_GINT1_REG	0x008	TCON global interrupt register1
TCON0_FRM_CTL_REG	0x010	TCON FRM control register
TCON0_FRM_SEED_REG	0x014+N*0x04	TCON FRM seed register (N=0,1,2,3,4,5)
TCON0_FRM_TAB_REG	0x02C+N*0x04	TCON FRM table register (N=0,1,2,3)
TCON0_CTL_REG	0x040	TCON0 control register
TCON0_DCLK_REG	0x044	TCON0 data clock register
TCON0_BASIC0_REG	0x048	TCON0 basic timing register0
TCON0_BASIC1_REG	0x04C	TCON0 basic timing register1
TCON0_BASIC2_REG	0x050	TCON0 basic timing register2
TCON0_BASIC3_REG	0x054	TCON0 basic timing register3
TCON0_HV_IF_REG	0x058	TCON0 hv panel interface register
TCON0_CPU_IF_REG	0x060	TCON0 cpu panel interface register
TCON0_CPU_WR_REG	0x064	TCON0 cpu panel write data register
TCON0_CPU_RD0_REG	0x068	TCON0 cpu panel read data register0
TCON0_CPU_RD1_REG	0x06C	TCON0 cpu panel read data register1
TCON0_IO_POL_REG	0x088	TCON0 IO polarity register
TCON0_IO_TRI_REG	0x08C	TCON0 IO control register
TCON_ECC_FIFO_REG	0x0F8	TCON ECC FIFO register
TCON_DEBUG_REG	0x0FC	TCON debug register
TCON_CEU_CTL_REG	0x100	TCON CEU control register

TCON_CEU_COEF_MUL_REG	0x110+N*0x04	TCON CEU coefficient register0 (N=0,1,2,4,5,6,8,9,10)
TCON_CEU_COEF_ADD_REG	0x11C+N*0x10	TCON CEU coefficient register1 (N=0,1,2)
TCON_CEU_COEF_RANG_REG	0x140+N*0x04	TCON CEU coefficient register2 (N=0,1,2)
TCON0_CPU_TRI0_REG	0x160	TCON0 cpu panel trigger register0
TCON0_CPU_TRI1_REG	0x164	TCON0 cpu panel trigger register1
TCON0_CPU_TRI2_REG	0x168	TCON0 cpu panel trigger register2
TCON0_CPU_TRI3_REG	0x16C	TCON0 cpu panel trigger register3
TCON_CMAP_CTL_REG	0x180	TCON color map control register
TCON_CMAP_ODD0_REG	0x190	TCON color map odd line register0
TCON_CMAP_ODD1_REG	0x194	TCON color map odd line register1
TCON_CMAP_EVEN0_REG	0x198	TCON color map even line register0
TCON_CMAP_EVEN1_REG	0x19C	TCON color map even line register1
TCON_SAFE_PERIOD_REG	0x1F0	TCON safe period register
TCON0_GAMMA_TABLE_REG	0x400-0x7FF	
TCON_TRI_FIFO_BIST_REG	0xFF8	
TCON_ECC_FIFO_BIST_REG	0xFFC	

## 7.2.5. TCON Module Register Description

### 7.2.5.1. TCON\_GCTL\_REG (Default Value: 0x00000000)

Offset: 0x0000			Register Name: <b>TCON_GCTL_REG</b>
Bit	R/W	Default/Hex	Description
31	R/W	0	TCON_En 0: disable 1: enable When it's disabled, the module will be reset to idle state.
30	R/W	0	TCON_Gamma_En 0: disable 1: enable
29:0	/	/	/

### 7.2.5.2. TCON\_GINT0\_REG (Default Value: 0x00000000)

Offset: 0x0004			Register Name: <b>TCON_GINT0_REG</b>
Bit	R/W	Default/Hex	Description
31	R/W	0	TCON0_Vb_Int_En 0: disable

			1: enable
30	/	/	/
29	R/W	0	TCON0_Line_Int_En 0: disable 1: enable
28	/	/	/1: enable
27	R/W	0	TCON0_Tri_Finish_Int_En 0: disable 1: enable
26:	R/W	0	TCON0_Tri_Counter_Int_En 0: disable 1: enable
25:16	/	/	/
15	R/W	0	TCON0_Vb_Int_Flag Asserted during vertical no-display period every frame. Write 0 to clear it.
14	/	/	/
13	R/W	0	TCON0_Line_Int_Flag trigger when SY0 match the current TCON0 scan line Write 0 to clear it.
12	/	/	/
11	R/W	0	TCON0_Tri_Finish_Int_Flag trigger when cpu trigger mode finish Write 0 to clear it.
10	R/W	0	TCON0_Tri_Counter_Int_Flag trigger when tri counter reache this value Write 0 to clear it.
9	R/W	0	TCON0_Tri_Underflow_Flag only used in dsi video mode, tri when sync by dsi but not finish Write 0 to clear it.
8:0	/	/	/

### 7.2.5.3. TCON\_GINT1\_REG (Default Value: 0x00000000)

Offset: 0x0008			Register Name: <b>TCON_GINT1_REG</b>
Bit	R/W	Default/Hex	Description
31:28	/	/	/
27:16	R/W	0	TCON0_Line_Int_Num Scan line for TCON0 line trigger(including inactive lines) Setting it for the specified line for trigger0. Note: SY0 is writable only when LINE_TRG0 disable.
15:0	/	/	/

**7.2.5.4. TCON0\_TRM\_CTL\_REG (Default Value: 0x00000000)**

Offset: 0x010			Register Name: TCON0_FRM_CTL_REG
Bit	R/W	Default/Hex	Description
31	R/W	0	TCON0_Frm_En 0:disable 1:enable
30:7	/	/	/
6	R/W	0	TCON0_Frm_Mode_R 0: 6bit frm output 1: 5bit frm output
5	R/W	0	TCON0_Frm_Mode_G 0: 6bit frm output 1: 5bit frm output
4	R/W	0	TCON0_Frm_Mode_B 0: 6bit frm output 1: 5bit frm output
3:2	/	/	/
1:0	R/W	0	TCON0_Frm_Test 00: FRM 01: half 5/6bit, half FRM 10: half 8bit, half FRM 11: half 8bit, half 5/6bit

**7.2.5.5. TCON0\_FRM\_SEED\_REG (Default Value: 0x00000000)**

Offset: 0x014+N*0x04 (N=0,1,2,3,4,5)			Register Name: TCON0_FRM_SEED_REG
Bit	R/W	Default/Hex	Description
31:25	/	/	/
24:0	R/W	0	Seed_Value N=0: Pixel_Seed_R N=1: Pixel_Seed_G N=2: Pixel_Seed_B N=3: Line_Seed_R N=4: Line_Seed_G N=5: Line_Seed_B Note: avoid set it to 0

**7.2.5.6. TCON0\_FRM\_TAB\_REG (Default Value: 0x00000000)**

Offset: 0x02C+N*0x04			Register Name: TCON0_FRM_TAB_REG
----------------------	--	--	----------------------------------

(N=0,1,2,3)			
Bit	R/W	Default/Hex	Description
31:0	R/W	0	Frm_Table_Value

**7.2.5.7. TCON0\_CTL\_REG (Default Value: 0x00000000)**

Offset: 0x040			Register Name: TCON0_CTL_REG
Bit	R/W	Default/Hex	Description
31	R/W	0	TCON0_En 0: disable 1: enable Note: It executes at the beginning of the first blank line of TCON0 timing.
30:29	/	/	/
28	R/W	0	TCON0_Work_Mode 0: normal 1: dynamic freq
27:26	/	/	/
25:24	R/W	0	TCON0_IF 00: HV(Sync+DE) 01: 8080 I/F 1x:reserved
23	R/W	0	TCON0_RB_Swap 0: default 1: swap RED and BLUE data at FIFO1
22	/	/	/
21	R/W	0	TCON0_FIFO1_Rst Write 1 and then 0 at this bit will reset FIFO 1 Note: 1 holding time must more than 1 DCLK
20	/	/	/
19:9	/	/	/
8:4	R/W	0	TCON0_Start_Delay STA delay NOTE: valid only when TCON0_EN == 1
3	/	/	/
2:0	R/W	0	TCON0_SRC_SEL: 000: DE0 001: reserved 010: reserved 011: reserved 100: Test Data all 0 101: Test Data all 1 11x: reserved

**7.2.5.8. TCON0\_DCLK\_REG (Default Value: 0x00000000)**

Offset: 0x044			Register Name: TCON0_DCLK_REG
Bit	R/W	Default/Hex	Description
31:28	R/W	0	TCON0_Dclk_En LCLK_EN[3:0] :TCON0 clock enable 4'h0, 'h4,4'h6,4'ha7:dclk_en=0;dclk1_en=0;dclk2_en=0;dclkm2_en=0; 4'h1: dclk_en = 1; dclk1_en = 0; dclk2_en = 0; dclkm2_en = 0; 4'h2: dclk_en = 1; dclk1_en = 0; dclk2_en = 0; dclkm2_en = 1; 4'h3: dclk_en = 1; dclk1_en = 1; dclk2_en = 0; dclkm2_en = 0; 4'h5: dclk_en = 1; dclk1_en = 0; dclk2_en = 1; dclkm2_en = 0; 4'h8,4'h9,4'ha,4'hb,4'hc,4'hd,4'he,4'hf: dclk_en = 1; dclk1_en = 1; dclk2_en = 1; dclkm2_en = 1;
27:7	/	/	/
6:0	R/W	0	TCON0_Dclk_Div $Tdclk = Tscclk * DCLKDIV$ Note: 1.if dclk1&dclk2 used, DCLKDIV >=6 2.if dclk only, DCLKDIV >=1

**7.2.5.9. TCON0\_BASIC0\_REG (Default Value: 0x00000000)**

Offset: 0x048			Register Name: TCON0_BASIC0_REG
Bit	R/W	Default/Hex	Description
31:28	/	/	/
27:16	R/W	0	TCON0_X Panel width is X+1
15:12	/	/	/
11:0	R/W	0	TCON0_Y Panel height is Y+1

**7.2.5.10. TCON0\_BASIC1\_REG (Default Value: 0x00000000)**

Offset: 0x04C			Register Name: TCON0_BASIC1_REG
Bit	R/W	Default/Hex	Description
31:29	/	/	/
28:16	R/W	0	HT $Thcycle = (HT+1) * Tdclk$ Computation 1) parallel:HT = X + BLANK



			Limitation: 1) parallel :HT >= (HBP +1) + (X+1) +2 2) serial 1: HT >= (HBP +1) + (X+1) *3+2 3) serial 2: HT >= (HBP +1) + (X+1) *3/2+2
15:12	/	/	/
11:0	R/W	0	HBP horizontal back porch (in dclk) $Thbp = (HBP +1) * Tdclk$

**7.2.5.11. TCON0\_BASIC2\_REG (Default Value: 0x00000000)**

Offset: 0x050			Register Name: <b>TCON0_BASIC2_REG</b>
Bit	R/W	Default/Hex	Description
31:29	/	/	/
28:16	R/W	0	VT $TVT = (VT)/2 * Thsync$ Note: $VT/2 >= (VBP+1) + (Y+1) +2$
15:12	/	/	/
11:0	R/W	0	VBP $Tvbp = (VBP +1) * Thsync$

**7.2.5.12. TCON0\_BASIC3\_REG (Default Value: 0x00000000)**

Offset: 0x054			Register Name: <b>TCON0_BASIC3_REG</b>
Bit	R/W	Default/Hex	Description
31:26	/	/	/
25:16	R/W	0	HSPW $Thspw = (HSPW+1) * Tdclk$ Note: $HT > (HSPW+1)$
15:10	/	/	/
9:0	R/W	0	VSPW $Tvspw = (VSPW+1) * Thsync$ Note: $VT/2 > (VSPW+1)$

**7.2.5.13. TCON0\_HV\_IF\_REG (Default Value: 0x00000000)**

Offset: 0x058			Register Name: <b>TCON0_HV_IF_REG</b>
Bit	R/W	Default/Hex	Description
31:28	R/W	0	HV_Mode 0000: 24bit/1cycle parallel mode 1000: 8bit/3cycle RGB serial mode(RGB888)

			1010: 8bit/4cycle Dummy RGB(DRGB) 1011: 8bit/4cycle RGB Dummy(RGBD) 1100: 8bit/2cycle YUV serial mode(CCIR656)
27:26	R/W	0	RGB888_SM0 serial RGB888 mode Output sequence at odd lines of the panel (line 1, 3, 5, 7...) 00: R→G→B 01: B→R→G 10: G→B→R 11: R→G→B
25:24	R/W	0	RGB888_SM1 serial RGB888 mode Output sequence at even lines of the panel (line 2, 4, 6, 8...) 00: R→G→B 01: B→R→G 10: G→B→R 11: R→G→B
23:22	R/W	0	YUV_SM serial YUV mode Output sequence 2-pixel-pair of every scan line 00: YUYV 01: YVYU 10: UYVY 11: VYUY
21:20	R/W	0	YUV EAV/SAV F line delay 0:F toggle right after active video line 1:delay 2 line(CCIR PAL) 2:delay 3 line(CCIR NTSC) 3:reserved
19:0	/	/	/

**7.2.5.14. TCON0\_CPU\_IF\_REG (Default Value: 0x00000000)**

Offset: 0x060			Register Name: <b>TCON0_CPU_IF_REG</b>
Bit	R/W	Default/Hex	Description
31:28	R/W	0	CPU_Mode 0000: 18bit/256K mode 0010: 16bit mode0 0100: 16bit mode1 0110: 16bit mode2 1000: 16bit mode3 1010: 9bit mode 1100: 8bit 256K mode 1110: 8bit 65K mode xxx1: 24bit for DSI

27	/	/	/
26	R/W	0	DA pin A1 value in 8080 mode auto/flash states
25	R/W	0	CA pin A1 value in 8080 mode WR/RD execute
24	/	/	/
23	R	0	Wr_Flag 0:write operation is finishing 1:write operation is pending
22	R	0	Rd_Flag 0:read operation is finishing 1:read operation is pending
21:18	/	/	/
17	R/W	0	AUTO auto Transfer Mode: If it's 1, all the valid data during this frame are write to panel. Note: This bit is sampled by Vsync
16	R/W	0	FLUSH direct transfer mode: If it's enabled, FIFO1 is regardless of the HV timing, pixels data keep being transferred unless the input FIFO was empty. Data output rate control by DCLK.
15:6	/	/	/
5:4	R/W	0	/
3	R/W	0	Trigger_FIFO_Bist_En 0: disable 1: enable Entry addr is 0xFF8
2	R/W	0	Trigger_FIFO_En 0:enable 1:disable
1	R/W	0	Trigger_Start write '1' to start a frame flush, write'0' has no effect. this flag indicated frame flush is running software must make sure write '1' only when this flag is '0'.
0	R/W	0	Trigger_En 0: trigger mode disable 1: trigger mode enable

**7.2.5.15. TCON0\_CPU\_WR\_REG (Default Value: 0x00000000)**

Offset: 0x064		Register Name: TCON0_CPU_WR_REG	
Bit	R/W	Default/Hex	Description

31:24	/	/	/
23:0	W	0	Data_Wr data write on 8080 bus, launch a write operation on 8080 bus

**7.2.5.16. TCON0\_CPU\_RD0\_REG (Default Value: 0x00000000)**

Offset: 0x068			Register Name: <b>TCON0_CPU_RD0_REG</b>
Bit	R/W	Default/Hex	Description
31:24	/	/	/
23:0	R	/	Data_Rd0 data read on 8080 bus, launch a new read operation on 8080 bus

**7.2.5.17. TCON0\_CPU\_RD1\_REG (Default Value: 0x00000000)**

Offset: 0x6C			Register Name: <b>TCON0_CPU_RD1_REG</b>
Bit	R/W	Default/Hex	Description
31:24	/	/	/
23:0	R	/	Data_Rd1 data read on 8080 bus, without a new read operation on 8080 bus

**7.2.5.18. TCON0\_IO\_POL\_REG (Default Value: 0x00000000)**

Offset: 0x88			Register Name: <b>TCON0_IO_POL_REG</b>
Bit	R/W	Default/Hex	Description
31	R/W	0	IO_Output_Sel 0: normal output 1: register output when set as '1', d[23:0], io0, io1,io3 sync to dclk
30:28	R/W	0	DCLK_Sel 000: used DCLK0(normal phase offset) 001: used DCLK1(1/3 phase offset) 010: used DCLK2(2/3 phase offset) 101: DCLK0/2 phase 0 100: DCLK0/2 phase 90 reserved
27	R/W	0	IO3_Inv 0: not invert 1: invert
26	R/W	0	IO2_Inv 0: not invert 1: invert

25	R/W	0	IO1_Inv 0: not invert 1: invert
24	R/W	0	IO0_Inv 0: not invert 1: invert
23:0	R/W	0	Data_Inv TCON0 output port D[23:0] polarity control, with independent bit control: 0s: normal polarity 1s: invert the specify output

**7.2.5.19. TCON0\_IO\_TRI\_REG (Default Value: 0x0FFFFFFF)**

Offset: 0x08C			Register Name: <b>TCON0_IO_TRI_REG</b>
Bit	R/W	Default/Hex	Description
31:29	/	/	/
28	/	/	RGB_Endian 0: normal 1: bits_invert
27	R/W	1	IO3_Output_Tri_En 1: disable 0: enable
26	R/W	1	IO2_Output_Tri_En 1: disable 0: enable
25	R/W	1	IO1_Output_Tri_En 1: disable 0: enable
24	R/W	1	IO0_Output_Tri_En 1: disable 0: enable
23:0	R/W	0xFFFFFFFF	Data_Output_Tri_En TCON0 output port D[23:0] output enable, with independent bit control: 1s: disable 0s: enable

**7.2.5.20. TCON\_ECC\_FIFO\_REG (Default Value: 0x00000000)**

Offset: 0x0F8			Register Name: <b>TCON_ECC_FIFO_REG</b>
Bit	R/W	Default/Hex	Description
31	R/W	/	ECC_FIFO_BIST_EN 0: disable

			1: enable
30	R/W	/	ECC_FIFO_ERR_FLAG
29:24	/	/	/
23:16	R/W	/	ECC_FIFO_ERR_BITS
15:9	/	/	/
8	R/W	0	ECC_FIFO_BLANK_EN 0: disable ecc function in blanking 1: enable ecc function in blanking ECC function is tent to trigged in blanking area at hv mode, set '0' when in hv mode
7:0	R/W	/	ECC_FIFO_SETTING Note: bit3 0 enable, 1 disable

**7.2.5.21. TCON\_DEBUG\_REG (Default Value: 0x00000000)**

Offset: 0x0FC			Register Name: <b>TCON_DEBUG_REG</b>
Bit	R/W	Default/Hex	Description
31	R/W	/	TCON0_FIFO_Under_Flow
30	/	/	/
29	R	/	TCON0_Field_Polarity 0: second field 1: first field
28	/	/	/
27:16	R	/	TCON0_Current_Line
15:14	/	/	/
13	R/W	0	ECC_FIFO_Bypass 0: used 1: bypass
12:0	/	/	/

**7.2.5.22. TCON\_CEU\_CTL\_REG (Default Value: 0x00000000)**

Offset: 0x100			Register Name: <b>TCON_CEU_CTL_REG</b>
Bit	R/W	Default/Hex	Description
31	R/W	0	CEU_en 0: bypass 1: enable
30:0	/	/	/

**7.2.5.23. TCON\_CEU\_COEF\_MUL\_REG (Default Value: 0x00000000)**

Offset: 0x110+N*0x04 (N=0,1,2,4,5,6,8,9,10)			Register Name: TCON_CEU_COEF_MUL_REG
Bit	R/W	Default/Hex	Description
31:13	/	/	/
12:0	R/W	0	CEU_Coef_Mul_Value signed 13bit value, range of (-16,16) N=0: Rr N=1: Rg N=2: Rb N=4: Gr N=5: Gg N=6: Gb N=8: Br N=9: Bg N=10: Bb

**7.2.5.24. TCON\_CEU\_COEF\_ADD\_REG (Default Value: 0x00000000)**

Offset: 0x11C+N*0x10 (N=0,1,2)			Register Name: TCON_CEU_COEF_ADD_REG
Bit	R/W	Default/Hex	Description
31:19	/	/	/
18:0	R/W	0	CEU_Coef_Add_Value signed 19bit value, range of (-16384, 16384) N=0: Rc N=1: Gc N=2: Bc

**7.2.5.25. TCON\_CEU\_COEF\_RANG\_REG (Default Value: 0x00000000)**

Offset: 0x140+N*0x04 (N=0,1,2)			Register Name: TCON_CEU_COEF_RANG_REG
Bit	R/W	Default/Hex	Description
31:24	/	/	/
23:16	R/W	0	CEU_Coef_Range_Min unsigned 8bit value, range of [0,255]
15:8	/	/	/
7:0	R/W	0	CEU Coef_Range_Max unsigned 8bit value, range of [0,255]

**7.2.5.26. TCON0\_CPU\_TRIO\_REG (Default Value: 0x00000000)**

Offset: 0x160			Register Name: <b>TCON0_CPU_TRIO_REG</b>
Bit	R/W	Default/Hex	Description
31:28	/	/	/
27:16	R/W	0	Block_Space should be set >20*pixel_cycle
15:12	/	/	/
11:0	R/W	0	Block_Size

**7.2.5.27. TCON0\_CPU\_TRI1\_REG (Default Value: 0x00000000)**

Offset: 0x164			Register Name: <b>TCON0_CPU_TRI1_REG</b>
Bit	R/W	Default/Hex	Description
31:16	R	0	Block_Current_Num
15:0	R/W	0	Block_Num

**7.2.5.28. TCON0\_CPU\_TRI2\_REG (Default Value: 0x00200000)**

Offset: 0x168			Register Name: <b>TCON0_CPU_TRI2_REG</b>
Bit	R/W	Default/Hex	Description
31:16	R/W	0x20	Start_Delay $Tdly = (Start\_Delay + 1) * be\_clk * 8$
15	R/W	0	Trans_Start_Mode 0: ecc_fifo+tri_fifo 1: tri_fifo
14:13	R/W	0	Sync_Mode 0x: auto 10: 0 11: 1
12:0	R/W	0	Trans_Start_Set

**7.2.5.29. TCON0\_CPU\_TRI3\_REG (Default Value: 0x00000000)**

Offset: 0x16C			Register Name: <b>TCON0_CPU_TRI3_REG</b>
Bit	R/W	Default/Hex	Description
31:30	/	/	/
29:28	R/W	0	Tri_Int_Mode 00: disable 01: counter mode



			10: te rising mode 11: te falling mode when set as 01, Tri_Counter_Int occur in cycle of $(Count\_N+1) \times (Count\_M+1) \times 4$ dclk. when set as 10 or 11, io0 is map as TE input.
27:24	/	/	/
23:8	R/W	0	Counter_N
7:0	R/W	0	Counter_M

**7.2.5.30. TCON\_CMAP\_CTL\_REG (Default Value: 0x00000000)**

Offset: 0x180			Register Name: TCON_CMAP_CTL_REG
Bit	R/W	Default/Hex	Description
31	R/W	0	Color_Map_En 0: bypass 1: enable This module only work when X is divided by 4
30:1	/	/	/
0	R/W	0	Out_Format 0: 4 pixel output mode: Out0 -> Out1 -> Out2 -> Out3 1: 2 pixel output mode: Out0 -> Out1

**7.2.5.31. TCON\_CMAP\_ODD0\_REG (Default Value: 0x00000000)**

Offset: 0x190			Register Name: TCON_CMAP_ODD0_REG
Bit	R/W	Default/Hex	Description
31:16	R/W	0	Out_Odd1
15:0	R/W	0	Out_Odd0 bit15-12: Reservd bit11-08: Out_Odd0[23:16] bit07-04: Out_Odd0[15:8] bit03-00: Out_Odd0[7:0] 0x0: in_b0 0x1: in_g0 0x2: in_r0 0x3: reservd 0x4: in_b1 0x5: in_g1 0x6: in_r1 0x7: reservd 0x8: in_b2 0x9: in_g2

			0xa: in_r2 0xb: reservd 0xc: in_b3 0xd: in_g3 0xe: in_r3 0xf: reservd
--	--	--	--

**7.2.5.32. TCON\_CMAP\_ODD1\_REG (Default Value: 0x00000000)**

Offset: 0x194			Register Name: <b>TCON_CMAP_ODD1_REG</b>
Bit	R/W	Default/Hex	Description
31:16	R/W	0	Out_Odd3
15:0	R/W	0	Out_Odd2

**7.2.5.33. TCON\_CMAP\_EVEN0\_REG (Default Value: 0x00000000)**

Offset: 0x198			Register Name: <b>TCON_CMAP_EVEN0_REG</b>
Bit	R/W	Default/Hex	Description
31:16	R/W	0	Out_Even1
15:0	R/W	0	Out_Even0

**7.2.5.34. TCON\_CMAP\_EVEN1\_REG (Default Value: 0x00000000)**

Offset: 0x19C			Register Name: <b>TCON_CMAP_EVEN1_REG</b>
Bit	R/W	Default/Hex	Description
31:16	R/W	0	Out_Even3
15:0	R/W	0	Out_Even2

**7.2.5.35. TCON\_SAFE\_PERIOD\_REG (Default Value: 0x00000000)**

Offset: 0x1F0			Register Name: <b>TCON_SAFE_PERIOD_REG</b>
Bit	R/W	Default/Hex	Description
31:29	/	/	/
28:16	R/W	0	Safe_Period_FIFO_Num
15:2	/	/	/
1:0	R/W	0	Safe_Period_Mode 0: unsafe 1: safe 2: safe at ecc_fifo_curr_num > safe_period_fifo_num

---

			3: safe at 2 and safe at sync active
--	--	--	--------------------------------------

## Chapter 8 Interfaces

This chapter describes the V3s interfaces, including:

- TWI
- SPI
- UART
- USB
- EMAC

## 8.1. TWI

### 8.1.1. Overview

This TWI Controller is designed to be used as an interface between CPU host and the serial TWI bus. It can support all the standard TWI transfer, including Slave and Master. The communication to the TWI bus is carried out on a byte-wise basis using interrupt or polled handshaking. This TWI Controller can be operated in standard mode (100K bps) or fast-mode, supporting data rate up to 400K bps. Multiple Masters and 10-bit addressing Mode are supported for this specified application. General Call Addressing is also supported in Slave mode.

The TWI Controller includes the following features:

- Software-programmable for Slave or Master
- Support Repeated START signal
- Multi-master systems supported
- Allow 10-bit addressing with TWI bus
- Performs arbitration and clock synchronization
- Own address and General Call address detection
- Interrupt on address detection
- Support speeds up to 400Kbits/s ('fast mode')
- Allow operation from a wide range of input clock frequencies

### 8.1.2. Timing Diagram

Data transferred are always in a unit of 8-bit (byte), followed by an acknowledge bit. The number of bytes that can be transmitted per transfer is unrestricted. Data is transferred in serial with the MSB first. Between each byte of data transfer, a receiver device will hold the clock line SCL low to force the transmitter into a wait state while waiting the response from microprocessor.

Data transfer with acknowledge is obligatory. The clock line is driven by the master all the time, including the acknowledge-related clock cycle, except for the SCL holding between each bytes. After sending each byte, the transmitter releases the SDA line to allow the receiver to pull down the SDA line and send an acknowledge signal (or leave it high to send a "not acknowledge") to the transmitter.

When a slave receiver doesn't acknowledge the slave address (unable to receive because of no resource available), the data line must be left high by the slave so that the master can then generate a STOP condition to abort the transfer. Slave receiver can also indicate not to want to send more data during a transfer by leave the acknowledge signal high. And the master should generate the STOP condition to abort the transfer.

Below diagram provides an illustration the relation of SDA signal line and SCL signal line on the TWI serial bus.

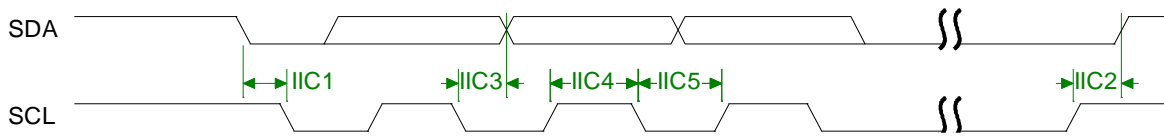

Figure 8-1 . TWI Timing Diagram

### 8.1.3. TWI Controller Special Requirement

#### 8.1.3.1. TWI Pin List

Port Name	Width	Direction	Description
TWI_SCL	1	IN/OUT	TWI Clock line
TWI_SDA	1	IN/OUT	TWI Serial Data line

#### 8.1.3.2. TWI Controller Operation

There are four operation modes on the TWI bus which dictates the communications method. They are Master Transmit, Master Receive, Slave Transmit and Slave Receive. In general, CPU host controls TWI by writing commands and data to its registers. The TWI interrupts the CPU host for the attention each time a byte transfer is done or a START/STOP conditions is detected. The CPU host can also poll the status register for current status if the interrupt mechanism is not disabled by the CPU host.

When the CPU host wants to start a bus transfer, it initiates a bus START to enter the master mode by setting IM\_STA bit in the 2WIRE\_CNTR register to high (before it must be low). The TWI will assert INT line and INT\_FLAG to indicate a completion for the START condition and each consequent byte transfer. At each interrupt, the micro-processor needs to check the 2WIRE\_STAT register for current status. A transfer has to be concluded with STOP condition by setting M\_STP bit high.

In Slave Mode, the TWI also constantly samples the bus and look for its own slave address during addressing cycles. Once a match is found, it is addressed and interrupt the CPU host with the corresponding status. Upon request, the CPU host should read the status, read/write 2WIRE\_DATA data register, and set the 2WIRE\_CNTR control register. After each byte transfer, a slave device always halt the operation of remote master by holding the next low pulse on SCL line until the microprocessor responds to the status of previous byte transfer or START condition.

### 8.1.4. TWI Controller Register List

Module Name	Base Address
TWIO	0x01C2AC00

TWI1	0x01C2B000
------	------------

Register Name	Offset	Description
TWI_ADDR	0x0000	TWI Slave address
TWI_XADDR	0x0004	TWI Extended slave address
TWI_DATA	0x0008	TWI Data byte
TWI_CNTR	0x000C	TWI Control register
TWI_STAT	0x0010	TWI Status register
TWI_CCR	0x0014	TWI Clock control register
TWI_SRST	0x0018	TWI Software reset
TWI_EFR	0x001C	TWI Enhance Feature register
TWI_LCR	0x0020	TWI Line Control register

### 8.1.5. TWI Controller Register Description

#### 8.1.5.1. TWI Slave Address Register(Default Value: 0x00000000)

Offset: 0x00			Register Name: TWI_ADDR
Bit	R/W	Default/Hex	Description
31:8	/	/	/
7:1	R/W	0	SLA Slave address <ul style="list-style-type: none"> <li>7-bit addressing SLA6, SLA5, SLA4, SLA3, SLA2, SLA1, SLA0</li> <li>10-bit addressing 1, 1, 1, 1, 0, SLAX[9:8]</li> </ul>
0	R/W	0	GCE General call address enable 0: Disable 1: Enable

**Notes:**

For 7-bit addressing:

SLA6 – SLA0 is the 7-bit address of the TWI when in slave mode. When the TWI receives this address after a START condition, it will generate an interrupt and enter slave mode. (SLA6 corresponds to the first bit received from the TWI bus.) If GCE is set to '1', the TWI will also recognize the general call address (00h).

For 10-bit addressing:

When the address received starts with 11110b, the TWI recognizes this as the first part of a 10-bit address and if the next two bits match ADDR[2:1] (i.e. SLAX9 and SLAX8 of the device’s extended address), it sends an ACK. (The device does not generate an interrupt at this point.) If the next byte of the address matches the XADDR register (SLAX7 – SLAX0), the TWI generates an interrupt and goes into slave mode.

**8.1.5.2. TWI Extend Address Register(Default Value: 0x00000000)**

Offset: 0x04			Register Name: <b>TWI_XADDR</b>
Bit	R/W	Default/Hex	Description
31:8	/	/	/
7:0	R/W	0	SLAX Extend Slave Address SLAX[7:0]

**8.1.5.3. TWI Data Register(Default Value: 0x00000000)**

Offset: 0x08			Register Name: <b>TWI_DATA</b>
Bit	R/W	Default/Hex	Description
31:8	/	/	/
7:0	R/W	0	TWI_DATA Data byte for transmitting or received

**8.1.5.4. TWI Control Register(Default Value: 0x00000000)**

Offset: 0x0C			Register Name: <b>TWI_CNTR</b>
Bit	R/W	Default/Hex	Description
31:8	/	/	/
7	R/W	0	INT_EN Interrupt Enable 1'b0: The interrupt line always low 1'b1: The interrupt line will go high when INT_FLAG is set.
6	R/W	0	BUS_EN TWI Bus Enable 1'b0: The TWI bus inputs ISDA/ISCL are ignored and the TWI Controller will not respond to any address on the bus 1'b1: The TWI will respond to calls to its slave address – and to the general call address if the GCE bit in the ADDR register is set. Notes: In master operation mode, this bit should be set to '1'
5	R/W	0	M_STA Master Mode Start When M_STA is set to '1', TWI Controller enters master mode and will transmit a START condition on the bus when the bus is free. If the M_STA bit is set to '1' when the TWI Controller is already in master mode and one or more bytes have been transmitted, then a repeated START condition will be sent. If the M_STA bit is set to '1' when the TWI is being accessed in slave



			<p>mode, the TWI will complete the data transfer in slave mode then enter master mode when the bus has been released.</p> <p>The M_STA bit is cleared automatically after a START condition has been sent: writing a '0' to this bit has no effect.</p>
4	R/W	0	<p>M_STP Master Mode Stop</p> <p>If M_STP is set to '1' in master mode, a STOP condition is transmitted on the TWI bus. If the M_STP bit is set to '1' in slave mode, the TWI will behave as if a STOP condition has been received, but no STOP condition will be transmitted on the TWI bus. If both M_STA and M_STP bits are set, the TWI will first transmit the STOP condition (if in master mode) then transmit the START condition.</p> <p>The M_STP bit is cleared automatically: writing a '0' to this bit has no effect.</p>
3	R/W	0	<p>INT_FLAG Interrupt Flag</p> <p>INT_FLAG is automatically set to '1' when any of 28 (out of the possible 29) states is entered (see 'STAT Register' below). The only state that does not set INT_FLAG is state F8h. If the INT_EN bit is set, the interrupt line goes high when IFLG is set to '1'. If the TWI is operating in slave mode, data transfer is suspended when INT_FLAG is set and the low period of the TWI bus clock line (SCL) is stretched until '1' is written to INT_FLAG. The TWI clock line is then released and the interrupt line goes low.</p>
2	R/W	0	<p>A_ACK Assert Acknowledge</p> <p>When A_ACK is set to '1', an Acknowledge (low level on SDA) will be sent during the acknowledge clock pulse on the TWI bus if:</p> <ol style="list-style-type: none"> <li>1. Either the whole of a matching 7-bit slave address or the first or the second byte of a matching 10-bit slave address has been received.</li> <li>2. The general call address has been received and the GCE bit in the ADDR register is set to '1'.</li> <li>3. A data byte has been received in master or slave mode.</li> </ol> <p>When A_ACK is '0', a Not Acknowledge (high level on SDA) will be sent when a data byte is received in master or slave mode.</p> <p>If A_ACK is cleared to '0' in slave transmitter mode, the byte in the DATA register is assumed to be the 'last byte'. After this byte has been transmitted, the TWI will enter state C8h then return to the idle state (status code F8h) when INT_FLAG is cleared.</p> <p>The TWI will not respond as a slave unless A_ACK is set.</p>
1:0	R/W	0	/

#### 8.1.5.5. TWI Status Register(Default Value: 0x000000F8)

Offset: 0x10			Register Name: <b>TWI_STAT</b>
Bit	R/W	Default/Hex	Description

31:8	/	/	/
			STA Status Information Byte Code Status 0x00: Bus error 0x08: START condition transmitted 0x10: Repeated START condition transmitted 0x18: Address + Write bit transmitted, ACK received 0x20: Address + Write bit transmitted, ACK not received 0x28: Data byte transmitted in master mode, ACK received 0x30: Data byte transmitted in master mode, ACK not received 0x38: Arbitration lost in address or data byte 0x40: Address + Read bit transmitted, ACK received 0x48: Address + Read bit transmitted, ACK not received 0x50: Data byte received in master mode, ACK transmitted 0x58: Data byte received in master mode, not ACK transmitted 0x60: Slave address + Write bit received, ACK transmitted 0x68: Arbitration lost in address as master, slave address + Write bit received, ACK transmitted 0x70: General Call address received, ACK transmitted 0x78: Arbitration lost in address as master, General Call address received, ACK transmitted 0x80: Data byte received after slave address received, ACK transmitted 0x88: Data byte received after slave address received, not ACK transmitted 0x90: Data byte received after General Call received, ACK transmitted 0x98: Data byte received after General Call received, not ACK transmitted 0xA0: STOP or repeated START condition received in slave mode 0xA8: Slave address + Read bit received, ACK transmitted 0xB0: Arbitration lost in address as master, slave address + Read bit received, ACK transmitted 0xB8: Data byte transmitted in slave mode, ACK received 0xC0: Data byte transmitted in slave mode, ACK not received 0xC8: Last byte transmitted in slave mode, ACK received 0xD0: Second Address byte + Write bit transmitted, ACK received 0xD8: Second Address byte + Write bit transmitted, ACK not received 0xF8: No relevant status information, INT_FLAG=0 Others: Reserved
7:0	R	0xF8	

**8.1.5.6. TWI Clock Register(Default Value: 0x00000000)**

Offset: 0x14			Register Name: <b>TWI_CCR</b>
Bit	R/W	Default/Hex	Description
31:7	/	/	/
6:3	R/W	0	CLK_M

2:0	R/W	0	<p>CLK_N</p> <p>The TWI bus is sampled by the TWI at the frequency defined by F0:  <math>F_{\text{samp}} = F_0 = F_{\text{in}} / 2^{\text{CLK\_N}}</math></p> <p>The TWI OSCL output frequency, in master mode, is F1 / 10:  <math>F_1 = F_0 / (\text{CLK\_M} + 1)</math>  <math>F_{\text{oscl}} = F_1 / 10 = F_{\text{in}} / (2^{\text{CLK\_N}} * (\text{CLK\_M} + 1) * 10)</math></p> <p>For Example:  <math>F_{\text{in}} = 48\text{Mhz}</math> (APB clock input)          For 400kHz full speed 2Wire, CLK_N = 2, CLK_M=2  <math>F_0 = 48\text{M} / 2^2 = 12\text{Mhz}</math>, <math>F_1 = F_0 / (10 * (2+1)) = 0.4\text{Mhz}</math>          For 100Khz standard speed 2Wire, CLK_N=2, CLK_M=11  <math>F_0 = 48\text{M} / 2^2 = 12\text{Mhz}</math>, <math>F_1 = F_0 / (10 * (11+1)) = 0.1\text{Mhz}</math></p>
-----	-----	---	--

**8.1.5.7. TWI Soft Reset Register(Default Value: 0x00000000)**

Offset: 0x18			Register Name: <b>TWI_SRST</b>
Bit	R/W	Default/Hex	Description
31:1	/	/	/
0	R/W	0	<p>SOFT_RST</p> <p>Soft Reset</p> <p>Write '1' to this bit to reset the TWI and clear to '0' when completing Soft Reset operation.</p>

**8.1.5.8. TWI Enhance Feature Register(Default Value: 0x00000000)**

Offset: 0x1C			Register Name: <b>TWI_EFR</b>
Bit	R/W	Default/Hex	Description
31:2	/	/	/
0:1	R/W	0	<p>DBN</p> <p>Data Byte number follow Read Command Control</p> <p>0— No Data Byte to be written after read command          1— Only 1 byte data to be written after read command          2— 2 bytes data can be written after read command          3— 3 bytes data can be written after read command</p>

**8.1.5.9. TWI Line Control Register(Default Value: 0x0000003A)**

Offset: 0x20			Register Name: <b>TWI_LCR</b>
Bit	R/W	Default/Hex	Description

31:6	/	/	/
5	R	1	<p>SCL_STATE Current state of TWI_SCL 0 - low 1 - high</p>
4	R	1	<p>SDA_STATE Current state of TWI_SDA 0 - low 1 - high</p>
3	R/W	1	<p>SCL_CTL TWI_SCL line state control bit When line control mode is enabled (bit[2] set), value of this bit decide the output level of TWI_SCL 0 – output low level 1 – output high level</p>
2	R/W	0	<p>SCL_CTL_EN TWI_SCL line state control enable When this bit is set, the state of TWI_SCL is control by the value of bit[3]. 0-disable TWI_SCL line control mode 1-enable TWI_SCL line control mode</p>
1	R/W	1	<p>SDA_CTL TWI_SDA line state control bit When line control mode is enabled (bit[0] set), value of this bit decide the output level of TWI_SDA 0 – output low level 1 – output high level</p>
0	R/W	0	<p>SDA_CTL_EN TWI_SDA line state control enable When this bit is set, the state of TWI_SDA is control by the value of bit[1]. 0-disable TWI_SDA line control mode 1-enable TWI_SDA line control mode</p>

**8.1.5.10. TWI DVFS Control Register(Default Value: 0x00000000)**

Offset: 0x24			Register Name: <b>TWI_DVFSCR</b>
Bit	R/W	Default/Hex	Description
31:3	/	/	/
2	R/W	0	<p>MS_PRIORITY CPU and DVFS BUSY set priority select 0: CPU has higher priority 1: DVFS has higher priority</p>
1	R/W	0	<p>CPU_BUSY_SET CPU Busy set</p>

0	R/W	0	DVFC_BUSY_SET DVFS Busy set
---	-----	---	--------------------------------

**Notes:** This register is only implemented in TWI0.

## 8.2. SPI

### 8.2.1. Overview

The SPI is the Serial Peripheral Interface which allows rapid data communication with fewer software interrupts. It can interface with up to four slave external devices or one single external master. The SPI module contains one 64x8 receiver buffer (RXFIFO) and one 64x8 transmit buffer (TXFIFO). It can work at two modes: Master mode and Slave mode.

The SPI includes the following features:

- Full-duplex synchronous serial interface
- Master/Slave configurable
- Programmable clock granularity
- Up to four chip selects to support multiple peripherals
- 8-bit wide by 64-entry FIFO for both transmit and receive data
- Polarity and phase of the Chip Select (SPI\_SS) are configurable

### 8.2.2. SPI Timing Diagram

The serial peripheral interface master uses the SPI\_SCLK signal to transfer data in and out of the shift register. Data is clocked using any one of four programmable clock phase and polarity combinations.

During Phase 0, Polarity 0 and Phase 1, Polarity 1 operations, output data changes on the falling clock edge and input data is shifted in on the rising edge.

During Phase 1, Polarity 0 and Phase 0, Polarity 1 operations, output data changes on the rising edges of the clock and is shifted in on falling edges.

The POL defines the signal polarity when SPI\_SCLK is in idle state. The SPI\_SCLK is high level when POL is '1' and it is low level when POL is '0'. The PHA decides whether the leading edge of SPI\_SCLK is used for setup or sample data. The leading edge is used for setup data when PHA is '1' and for sample data when PHA is '0'. The four kind of modes are listed below:

Table 8-1. Four Mode of SPI

SPI Mode	POL	PHA	Leading Edge	Trailing Edge
0	0	0	Rising, Sample	Falling, Setup
1	0	1	Rising, Setup	Falling, Sample
2	1	0	Falling, Sample	Rising, Setup
3	1	1	Falling, Setup	Rising, Sample

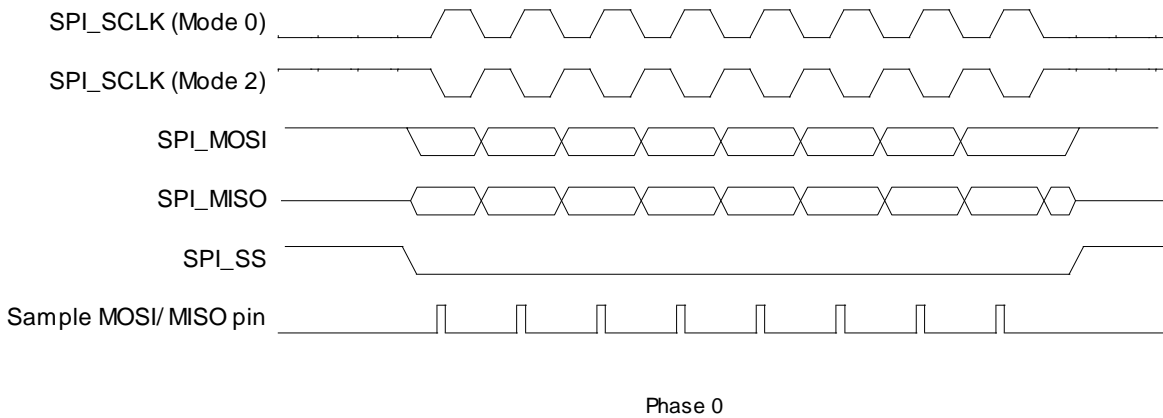

Figure 8-2 . SPI Phase 0 Timing Diagram

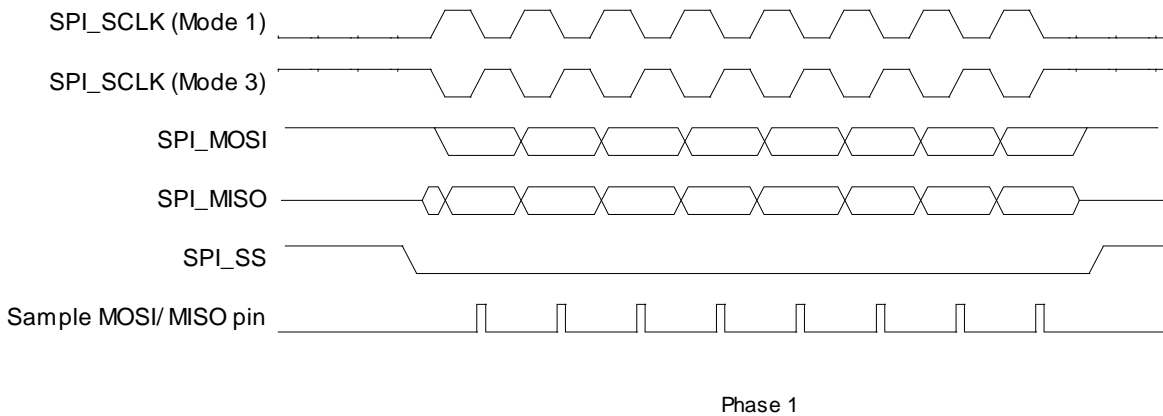

Figure 8-3. SPI Phase 1 Timing Diagram

### 8.2.3. SPI Special Requirement

#### 8.2.3.1. SPI Pin List

The direction of SPI pin is different in two work modes: Master Mode and Slave Mode.

Table 8-2. SPI Pin description

Port Name	Width	Direction(M)	Direction(S)	Description
SPI_SCLK	1	OUT	IN	SPI Clock
SPI_MOSI	1	OUT	IN	SPI Master Output Slave Input Data Signal
SPI_MISO	1	IN	OUT	SPI Master Input Slave Output Data Signal

SPI_SS[3:0]	4	OUT	IN	SPI Chip Select Signal
-------------	---	-----	----	------------------------

### 8.2.3.2. SPI Module Clock Source and Frequency

The SPI Controller get three different clocks, users can select one of them to make SPI Clock Source. The SPI\_SCLK can in the range from 3Khz to 100 MHZ.The following table describes the clock sources for SPI Controller.Users can see **Clock Controller Uint(CCU)** in chapter4 for clock setting,consiguration and gating information.

Table 8-3. SPI Clock Sources

Clock Name	Description
OSC24M	24MHz Crystal
PLL_PERIPH0	Peripheral Clock,default value is 600MHz
PLL_PERIPH1	Peripheral Clock,default value is 600MHz

### 8.2.4. SPI Register List

Module Name	Base Address
SPI0	0x01C68000

Register Name	Offset	Description
SPI_GCR	0x04	SPI Global Control Register
SPI_TCR	0x08	SPI Transfer Control register
/	0x0c	reserved
SPI_IER	0x10	SPI Interrupt Control register
SPI_ISR	0x14	SPI Interrupt Status register
SPI_FCR	0x18	SPI FIFO Control register
SPI_FSR	0x1C	SPI FIFO Status register
SPI_WCR	0x20	SPI Wait Clock Counter register
SPI_CCR	0x24	SPI Clock Rate Control register
/	0x28	reserved
/	0x2c	reserved
SPI_MBC	0x30	SPI Burst Counter register
SPI_MTC	0x34	SPI Transmit Counter Register
SPI_BCC	0x38	SPI Burst Control register
SPI_TXD	0x200	SPI TX Data register
SPI_RXD	0x300	SPI RX Data register



## 8.2.5. SPI Register Description

### 8.2.5.1. SPI Global Control Register(Default Value: 0x00000080)

Offset: 0x04			Register Name: <b>SPI_CTL</b>
Bit	R/W	Default/Hex	Description
31	R/W	0	<b>SRST</b> Soft reset Write '1' to this bit will clear the SPI controller, and auto clear to '0' when reset operation completes Write '0' has no effect.
30:8	/	/	/
7	R/W	1	<b>TP_EN</b> Transmit Pause Enable In master mode, it is used to control transmit state machine to stop smart burst sending when RX FIFO is full. 1 – stop transmit data when RXFIFO full 0 – normal operation, ignore RXFIFO status Note: Can't be written when XCH=1
6:2	/	/	/
1	R/W	0	<b>MODE</b> SPI Function Mode Select 0: Slave Mode 1: Master Mode Note: Can't be written when XCH=1
0	R/W	0	<b>EN</b> SPI Module Enable Control 0: Disable 1: Enable

### 8.2.5.2. SPI Transfer Control Register(Default Value: 0x00000087)

Offset: 0x08			Register Name: <b>SPI_INTCTL</b>
Bit	R/W	Default/Hex	Description
31	R/W	0x0	<b>XCH</b> Exchange Burst In master mode it is used to start SPI burst 0: Idle 1: Initiates exchange. Write "1" to this bit will start the SPI burst, and will auto clear after finishing the bursts transfer specified by BC. Write "1" to SRST will also clear this bit. Write '0' to this bit has no effect.

			Note: Can't be written when XCH=1.
30:14	/	/	/
13	R/W	0x0	SDM Master Sample Data Mode 0 - Delay Sample Mode 1 - Normal Sample Mode In Normal Sample Mode, SPI master samples the data at the correct edge for each SPI mode; In Delay Sample Mode, SPI master samples data at the edge that is half cycle delayed by the correct edge defined in respective SPI mode.
12	R/W	0x0	FBS First Transmit Bit Select 0: MSB first 1: LSB first Note: Can't be written when XCH=1.
11	R/W	0x0	SDC Master Sample Data Control Set this bit to '1' to make the internal read sample point with a delay of half cycle of SPI_CLK. It is used in high speed read operation to reduce the error caused by the time delay of SPI_CLK propagating between master and slave. 0 – normal operation, do not delay internal read sample point 1 – delay internal read sample point Note: Can't be written when XCH=1.
10	R/W	0x0	RPSM Rapids mode select Select Rapids mode for high speed write. 0: normal write mode 1: rapids write mode Note: Can't be written when XCH=1.
9	R/W	0x0	DDB Dummy Burst Type 0: The bit value of dummy SPI burst is zero 1: The bit value of dummy SPI burst is one Note: Can't be written when XCH=1.
8	R/W	0x0	DHB Discard Hash Burst In master mode it controls whether discarding unused SPI bursts 0: Receiving all SPI bursts in BC period 1: Discard unused SPI bursts, only fetching the SPI bursts during dummy burst period. The bursts number is specified by TC. Note: Can't be written when XCH=1.
7	R/W	0x1	SS_LEVEL When control SS signal manually (SPI_CTRL_REG.SS_CTRL==1), set this bit to '1' or '0' to control the level of SS signal. 0: set SS to low

			1: set SS to high Note: Can't be written when XCH=1.
6	R/W	0x0	SS_OWNER SS Output Owner Select Usually, controller sends SS signal automatically with data together. When this bit is set to 1, software must manually write SPI_CTL_REG.SS_LEVEL to 1 or 0 to control the level of SS signal. 0: SPI controller 1: Software Note: Can't be written when XCH=1.
5:4	R/W	0x0	SS_SEL SPI Chip Select Select one of four external SPI Master/Slave Devices 00: SPI_SS0 will be asserted 01: SPI_SS1 will be asserted 10: SPI_SS2 will be asserted 11: SPI_SS3 will be asserted Note: Can't be written when XCH=1.
3	R/W	0x0	SSCTL In master mode, this bit selects the output wave form for the SPI_SSx signal. Only valid when SS_OWNER = 0. 0: SPI_SSx remains asserted between SPI bursts 1: Negate SPI_SSx between SPI bursts Note: Can't be written when XCH=1.
2	R/W	0x1	SPOL SPI Chip Select Signal Polarity Control 0: Active high polarity (0 = Idle) 1: Active low polarity (1 = Idle) Note: Can't be written when XCH=1.
1	R/W	0x1	CPOL SPI Clock Polarity Control 0: Active high polarity (0 = Idle) 1: Active low polarity (1 = Idle) Note: Can't be written when XCH=1.
0	R/W	0x1	CPHA SPI Clock/Data Phase Control 0: Phase 0 (Leading edge for sample data) 1: Phase 1 (Leading edge for setup data) Note: Can't be written when XCH=1.

### 8.2.5.3. SPI Interrupt Control Register(Default Value: 0x00000000)

Offset: 0x10			Register Name: <b>SPI_IER</b>
Bit	R/W	Default/Hex	Description

31:14	R	0x0	Reserved.
13	R/W	0x0	SS_INT_EN SSI Interrupt Enable Chip Select Signal (SSx) from valid state to invalid state 0: Disable 1: Enable
12	R/W	0x0	TC_INT_EN Transfer Completed Interrupt Enable 0: Disable 1: Enable
11	R/W	0x0	TF_UDR_INT_EN TXFIFO under run Interrupt Enable 0: Disable 1: Enable
10	R/W	0x0	TF_OVF_INT_EN TX FIFO Overflow Interrupt Enable 0: Disable 1: Enable
9	R/W	0x0	RF_UDR_INT_EN RXFIFO under run Interrupt Enable 0: Disable 1: Enable
8	R/W	0x0	RF_OVF_INT_EN RX FIFO Overflow Interrupt Enable 0: Disable 1: Enable
7	R	0x0	Reserved.
6	R/W	0x0	TF_FUL_INT_EN TX FIFO Full Interrupt Enable 0: Disable 1: Enable
5	R/W	0x0	TX_EMP_INT_EN TX FIFO Empty Interrupt Enable 0: Disable 1: Enable
4	R/W	0x0	TX_ERQ_INT_EN TX FIFO Empty Request Interrupt Enable 0: Disable 1: Enable
3	R	0x0	Reserved
2	R/W	0x0	RF_FUL_INT_EN RX FIFO Full Interrupt Enable 0: Disable 1: Enable
1	R/W	0x0	RX_EMP_INT_EN

			RX FIFO Empty Interrupt Enable 0: Disable 1: Enable
0	R/W	0x0	RF_RDY_INT_EN RX FIFO Ready Request Interrupt Enable 0: Disable 1: Enable

#### 8.2.5.4. SPI Interrupt Status Register(Default Value: 0x00000022)

Offset: 0x14			Register Name: <b>SPI_INT_STA</b>
Bit	R/W	Default/Hex	Description
31:14	/	0x0	/
13	R/W	0	SSI SS Invalid Interrupt When SSI is 1, it indicates that SS has changed from valid state to invalid state. Writing 1 to this bit clears it.
12	R/W	0	TC Transfer Completed In master mode, it indicates that all bursts specified by BC has been exchanged. In other condition, When set, this bit indicates that all the data in TXFIFO has been loaded in the Shift register, and the Shift register has shifted out all the bits. Writing 1 to this bit clears it. 0: Busy 1: Transfer Completed
11	R/W	0	TF_UDF TXFIFO Underrun This bit is set when if the TXFIFO is underrun. Writing 1 to this bit clears it. 0: TXFIFO is not underrun 1: TXFIFO is underrun
10	R/W	0	TF_OVF TXFIFO Overflow This bit is set when if the TXFIFO is overflow. Writing 1 to this bit clears it. 0: TXFIFO is not overflow 1: TXFIFO is overflowed
9	R/W	0	RX_UDF RXFIFO Underrun When set, this bit indicates that RXFIFO has underrun. Writing 1 to this bit clears it.
8	R/W	0	RX_OVF RXFIFO Overflow When set, this bit indicates that RXFIFO has overflowed. Writing 1 to this bit clears it. 0: RXFIFO is available.

			1: RXFIFO has overflowed.
7	/	/	/
6	R/W	0	TX_FULL TXFIFO Full This bit is set when if the TXFIFO is full . Writing 1 to this bit clears it. 0: TXFIFO is not Full 1: TXFIFO is Full
5	R/W	1	TX_EMP TXFIFO Empty This bit is set if the TXFIFO is empty. Writing 1 to this bit clears it. 0: TXFIFO contains one or more words. 1: TXFIFO is empty
4	R/W	0	TX_READY TXFIFO Ready 0: TX_WL > TX_TRIG_LEVEL 1: TX_WL <= TX_TRIG_LEVEL This bit is set any time if TX_WL <= TX_TRIG_LEVEL. Writing "1" to this bit clears it. Where TX_WL is the water level of RXFIFO
3	/	/	reserved
2	R/W	0	RX_FULL RXFIFO Full This bit is set when the RXFIFO is full . Writing 1 to this bit clears it. 0: Not Full 1: Full
1	R/W	1	RX_EMP RXFIFO Empty This bit is set when the RXFIFO is empty . Writing 1 to this bit clears it. 0: Not empty 1: empty
0	R/W	0	RX_RDY RXFIFO Ready 0: RX_WL < RX_TRIG_LEVEL 1: RX_WL >= RX_TRIG_LEVEL This bit is set any time if RX_WL >= RX_TRIG_LEVEL. Writing "1" to this bit clears it. Where RX_WL is the water level of RXFIFO.

#### 8.2.5.5. SPI FIFO Control Register(Default Value: 0x00400001)

Offset: 0x18			Register Name: <b>SPI_FCR</b>
Bit	R/W	Default/Hex	Description
31	R/W	0	TX_FIFO_RST TX FIFO Reset Write '1' to this bit will reset the control portion of the TX FIFO and auto clear to '0' when completing reset operation, write to '0' has no effect.

30	R/W	0	<p>TF_TEST_ENB TX Test Mode Enable 0: disable 1: enable</p> <p>Note: In normal mode, TX FIFO can only be read by SPI controller, write '1' to this bit will switch TX FIFO read and write function to AHB bus. This bit is used to test the TX FIFO, don't set in normal operation and don't set RF_TEST and TF_TEST at the same time.</p>
29:26	/	/	/
25	/	/	/
24	R/W	0x0	<p>TF_DRQ_EN TX FIFO DMA Request Enable 0: Disable 1: Enable</p>
23:16	R/W	0x40	<p>TX_TRIG_LEVEL TX FIFO Empty Request Trigger Level</p>
15	R/W	0x0	<p>RF_RST RXFIFO Reset Write '1' to this bit will reset the control portion of the receiver FIFO, and auto clear to '0' when completing reset operation, write '0' to this bit has no effect.</p>
14	R/W	0x0	<p>RF_TEST RX Test Mode Enable 0: Disable 1: Enable</p> <p>Note: In normal mode, RX FIFO can only be written by SPI controller, write '1' to this bit will switch RX FIFO read and write function to AHB bus. This bit is used to test the RX FIFO, don't set in normal operation and don't set RF_TEST and TF_TEST at the same time.</p>
13:10	R	0x0	Reserved
9	R/W	0x0	<p>RX_DMA_MODE SPI RX DMA Mode Control 0: Normal DMA mode 1: Dedicate DMA mode</p>
8	R/W	0x0	<p>RF_DRQ_EN RX FIFO DMA Request Enable 0: Disable 1: Enable</p>
7:0	R/W	0x1	<p>RX_TRIG_LEVEL RX FIFO Ready Request Trigger Level</p>

**8.2.5.6. SPI FIFO Status Register(Default Value: 0x00000000)**

Offset: 0x1C			Register Name: <b>SPI_FSR</b>
Bit	R/W	Default/Hex	Description
31	R	0x0	TB_WR TX FIFO Write Buffer Write Enable
30:28	R	0x0	TB_CNT TX FIFO Write Buffer Counter These bits indicate the number of words in TX FIFO Write Buffer
27:24	R	0x0	Reserved
23:16	R	0x0	TF_CNT TX FIFO Counter These bits indicate the number of words in TX FIFO 0: 0 byte in TX FIFO 1: 1 byte in TX FIFO ... 64: 64 bytes in TX FIFO
15	R	0x0	RB_WR RX FIFO Read Buffer Write Enable
14:12	R	0x0	RB_CNT RX FIFO Read Buffer Counter These bits indicate the number of words in RX FIFO Read Buffer
11:8	R	0x0	Reserved
7:0	R	0x0	RF_CNT RX FIFO Counter These bits indicate the number of words in RX FIFO 0: 0 byte in RX FIFO 1: 1 byte in RX FIFO ... 64:64 bytes in RX FIFO

**8.2.5.7. SPI Wait Clock Register(Default Value: 0x0000\_0000)**

Offset: 0x20			Register Name: <b>SPI_WAIT</b>
Bit	R/W	Default/Hex	Description
31:20	/	/	/
19:16	R/W	0x0	SWC Dual mode direction switch wait clock counter (for master mode only). 0: No wait states inserted n: n SPI_SCLK wait states inserted Note: These bits control the number of wait states to be inserted before start dual data transfer in dual SPI mode. The SPI module counts SPI_SCLK by SWC for delaying next word data transfer.



			Note: Can't be written when XCH=1.
15:0	R/W	0	WCC Wait Clock Counter (In Master mode) These bits control the number of wait states to be inserted in data transfers. The SPI module counts SPI_SCLK by WCC for delaying next word data transfer. 0: No wait states inserted N: N SPI_SCLK wait states inserted

#### 8.2.5.8. SPI Clock Control Register(Default Value: 0x00000002)

Offset: 0x24			Register Name: <b>SPI_CCTL</b>
Bit	R/W	Default/Hex	Description
31:13	/	/	/
12	R/W	0	DRS Divide Rate Select (Master Mode Only) 0: Select Clock Divide Rate 1 1: Select Clock Divide Rate 2
11:8	R/W	0	CDR1 Clock Divide Rate 1 (Master Mode Only) The SPI_SCLK is determined according to the following equation: $SPI\_CLK = Source\_CLK / 2^n$ .
7:0	R/W	0x2	CDR2 Clock Divide Rate 2 (Master Mode Only) The SPI_SCLK is determined according to the following equation: $SPI\_CLK = Source\_CLK / (2^{*(n + 1)})$ .

#### 8.2.5.9. SPI Master Burst Counter Register(Default Value: 0x00000000)

Offset: 0x30			Register Name: <b>SPI_BC</b>
Bit	R/W	Default/Hex	Description
31:24	/	/	/
23:0	R/W	0	MBC Master Burst Counter In master mode, this field specifies the total burst number when SMC is 1. 0: 0 burst 1: 1 burst ... N: N bursts

**8.2.5.10. SPI Master Transmit Counter Register(Default Value: 0x00000000)**

Offset: 0x34			Register Name: <b>SPI_TC</b>
Bit	R/W	Default/Hex	Description
31:24	/	/	/
23:0	R/W	0	<p>MWTC Master Write Transmit Counter</p> <p>In master mode, this field specifies the burst number that should be sent to TXFIFO before automatically sending dummy burst when SMC is 1. For saving bus bandwidth, the dummy burst (all zero bits or all one bits) is sent by SPI Controller automatically.</p> <p>0: 0 burst 1: 1 burst ... N: N bursts</p>

**8.2.5.11. SPI Master Burst Control Counter Register(Default Value: 0x00000000)**

Offset: 0x38			Register Name: <b>SPI_BCC</b>
Bit	R/W	Default/Hex	Description
31:29	R	0x0	Reserved
28	R/W	0x0	<p>DRM Master Dual Mode RX Enable</p> <p>0: RX use single-bit mode 1: RX use dual mode</p> <p>Note: Can't be written when XCH=1.</p>
27:24	R/W	0x0	<p>DBC Master Dummy Burst Counter</p> <p>In master mode, this field specifies the burst number that should be sent before receive in dual SPI mode. The data is don't care by the device.</p> <p>0: 0 burst 1: 1 burst ... N: N bursts</p> <p>Note: Can't be written when XCH=1.</p>
23:0	R/W	0x0	<p>STC Master Single Mode Transmit Counter</p> <p>In master mode, this field specifies the burst number that should be sent in single mode before automatically sending dummy burst. This is the first transmit counter in all bursts.</p> <p>0: 0 burst 1: 1 burst ...</p>

			N: N bursts Note: Can't be written when XCH=1.
--	--	--	---

**8.2.5.12. SPI TX Data Register(Default Value: 0x00000000)**

Offset: 0x200			Register Name: <b>SPI_TXD</b>
Bit	R/W	Default/Hex	Description
31:0	W/R	0x0	<p><b>TDATA</b> Transmit Data</p> <p>This register can be accessed in byte, half-word or word unit by AHB. In byte accessing method, if there are rooms in RXFIFO, one burst data is written to RXFIFO and the depth is increased by 1. In half-word accessing method, two SPI burst data are written and the TXFIFO depth is increase by 2. In word accessing method, four SPI burst data are written and the TXFIFO depth is increased by 4.</p> <p>Note: This address is writing-only if TF_TEST is '0', and if TF_TEST is set to '1', this address is readable and writable to test the TX FIFO through the AHB bus.</p>

**8.2.5.13. SPI RX Data Register(Default Value: 0x00000000)**

Offset: 0x300			Register Name: <b>SPI_RXD</b>
Bit	R/W	Default/Hex	Description
31:0	R	0	<p><b>RDATA</b> Receive Data</p> <p>This register can be accessed in byte, half-word or word unit by AHB. In byte accessing method, if there are data in RXFIFO, the top word is returned and the RXFIFO depth is decreased by 1. In half-word accessing method, two SPI bursts are returned and the RXFIFO depth is decrease by 2. In word accessing method, the four SPI bursts are returned and the RXFIFO depth is decreased by 4.</p> <p>Note: This address is read-only if RF_TEST is '0', and if RF_TEST is set to '1', this address is readable and writable to test the RX FIFO through the AHB bus.</p>

## 8.3. UART

### 8.3.1. Overview

The UART is used for serial communication with a peripheral, modem (data carrier equipment, DCE) or data set. Data is written from a master (CPU) over the APB bus to the UART and it is converted to serial form and transmitted to the destination device. Serial data is also received by the UART and stored for the master (CPU) to read back.

The UART contains registers to control the character length, baud rate, parity generation/checking, and interrupt generation. Although there is only one interrupt output signal from the UART, there are several prioritized interrupt types that can be responsible for its assertion. Each of the interrupt types can be separately enabled/disabled with the control registers.

The UART has 16450 and 16550 modes of operation, which are compatible with a range of standard software drivers. In 16550 mode, transmit and receive operations are both buffered by FIFOs. In 16450 mode, these FIFOs are disabled.

The UART supports data lengths from five to eight bits, an optional parity bit and 1, 1 ½ or 2 stop bits, and is fully programmable by an AMBA APB CPU interface. A 16-bit programmable baud rate generator and an 8-bit scratch register are included, together with separate transmit and receive FIFOs. Eight modem control lines and a diagnostic loop-back mode are provided.

Interrupts can be generated for a range of TX Buffer/FIFO, RX Buffer/FIFO, Modem Status and Line Status conditions.

The UART includes the following features:

- Compatible with industry-standard 16550 UARTs
- 64-Bytes Transmit and receive data FIFOs
- DMA controller interface
- Software/ Hardware Flow Control
- Programmable Transmit Holding Register Empty interrupt
- Interrupt support for FIFOs, Status Change
- Support IrDA 1.0 SIR

### 8.3.2. UART Timing Diagram

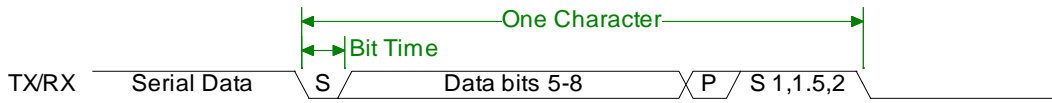

Figure 8-4. UART Serial Data Format

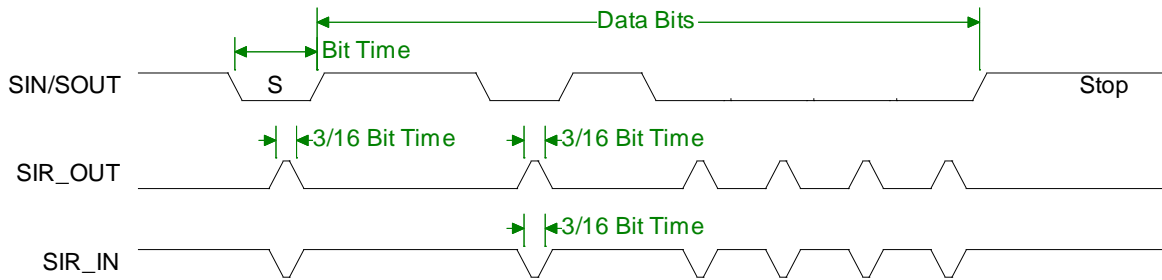

Figure 8-5. Serial IrDA Data Format

### 8.3.3. UART Pin List

Port Name	Width	Direction	Description
UART0_TX	1	OUT	UART Serial Bit output
UART0_RX	1	IN	UART Serial Bit input
UART1_TX	1	OUT	UART Serial Bit output
UART1_RX	1	IN	UART Serial Bit input
UART1_RTS	1	OUT	UART Request To Send This active low output signal informs Modem that the UART is ready to send data
UART1_CTS	1	IN	UART Clear To End This active low signal is an input showing when Modem is ready to accept data
UART2_TX	1	OUT	UART Serial Bit output
UART2_RX	1	IN	UART Serial Bit input
UART2_RTS	1	OUT	UART Request To Send This active low output signal informs Modem that the UART is ready to send data
UART2_CTS	1	IN	UART Clear To End This active low signal is an input showing when Modem is ready to accept data

### 8.3.4. UART Register List

There are 3 UART controllers. All UART controllers can be configured as Serial IrDA.

Module Name	Base Address
UART0	0x01C28000
UART1	0x01C28400
UART2	0x01C28800

Register Name	Offset	Description
UART_RBR	0x00	UART Receive Buffer Register
UART_THR	0x00	UART Transmit Holding Register
UART_DLL	0x00	UART Divisor Latch Low Register
UART_DLH	0x04	UART Divisor Latch High Register
UART_IER	0x04	UART Interrupt Enable Register
UART_IIR	0x08	UART Interrupt Identity Register
UART_FCR	0x08	UART FIFO Control Register
UART_LCR	0x0C	UART Line Control Register
UART_MCR	0x10	UART Modem Control Register
UART_LSR	0x14	UART Line Status Register
UART_MSR	0x18	UART Modem Status Register
UART_SCH	0x1C	UART Scratch Register
UART_USR	0x7C	UART Status Register
UART_TFL	0x80	UART Transmit FIFO Level
UART_RFL	0x84	UART_RFL
UART_HALT	0xA4	UART Halt TX Register

### 8.3.5. UART Register Description

#### 8.3.5.1. UART Receiver Buffer Register(Default Value: 0x00000000)

Offset: 0x0000			Register Name: <b>UART_RBR</b>
Bit	R/W	Default/Hex	Description
31:8	/	/	/
7:0	R	0	<p>RBR Receiver Buffer Register</p> <p>Data byte received on the serial input port . The data in this register is valid only if the Data Ready (DR) bit in the Line Status Register (LSR) is set.</p> <p>If in FIFO mode and FIFOs are enabled (FCR[0] set to one), this register accesses the head of the receive FIFO. If the receive FIFO is full and this register is not read before the next data character arrives, then the data already in the FIFO is preserved, but any incoming data are lost and an</p>

			overrun error occurs.
--	--	--	-----------------------

### 8.3.5.2. UART Transmit Holding Register(Default Value: 0x00000000)

Offset: 0x0000			Register Name: <b>UART_THR</b>
Bit	R/W	Default/Hex	Description
31:8	/	/	/
7:0	W	0	<p>THR Transmit Holding Register</p> <p>Data to be transmitted on the serial output port . Data should only be written to the THR when the THR Empty (THRE) bit (LSR[5]) is set.</p> <p>If in FIFO mode and FIFOs are enabled (FCR[0] = 1) and THRE is set, 16 number of characters of data may be written to the THR before the FIFO is full. Any attempt to write data when the FIFO is full results in the write data being lost.</p>

### 8.3.5.3. UART Divisor Latch Low Register(Default Value: 0x00000000)

Offset: 0x0000			Register Name: <b>UART_DLL</b>
Bit	R/W	Default/Hex	Description
31:8	/	/	/
7:0	R/W	0	<p>DLL Divisor Latch Low</p> <p>Lower 8 bits of a 16-bit, read/write, Divisor Latch register that contains the baud rate divisor for the UART. This register may only be accessed when the DLAB bit (LCR[7]) is set and the UART is not busy (USR[0] is zero).</p> <p>The output baud rate is equal to the serial clock (sclk) frequency divided by sixteen times the value of the baud rate divisor, as follows: baud rate = (serial clock freq) / (16 * divisor).</p> <p>Note that with the Divisor Latch Registers (DLL and DLH) set to zero, the baud clock is disabled and no serial communications occur. Also, once the DLL is set, at least 8 clock cycles of the slowest UART clock should be allowed to pass before transmitting or receiving data.</p>

### 8.3.5.4. UART Divisor Latch High Register(Default Value: 0x00000000)

Offset: 0x0004			Register Name: <b>UART_DLH</b>
Bit	R/W	Default/Hex	Description
31:8	/	/	/
7:0	R/W	0	<p>DLH Divisor Latch High</p> <p>Upper 8 bits of a 16-bit, read/write, Divisor Latch register that contains the</p>

			<p>baud rate divisor for the UART. This register may only be accessed when the DLAB bit (LCR[7]) is set and the UART is not busy (USR[0] is zero).</p> <p>The output baud rate is equal to the serial clock (sclk) frequency divided by sixteen times the value of the baud rate divisor, as follows: baud rate = (serial clock freq) / (16 * divisor).</p> <p>Note that with the Divisor Latch Registers (DLL and DLH) set to zero, the baud clock is disabled and no serial communications occur. Also, once the DLH is set, at least 8 clock cycles of the slowest UART clock should be allowed to pass before transmitting or receiving data.</p>
--	--	--	---

### 8.3.5.5. UART Interrupt Enable Register(Default Value: 0x00000000)

Offset: 0x0004			Register Name: <b>UART_IER</b>
Bit	R/W	Default/Hex	Description
31:8	/	/	/
7	R/W		<b>PTIME</b> Programmable THRE Interrupt Mode Enable This is used to enable/disable the generation of THRE Interrupt. 0: Disable 1: Enable
6:4	/	/	/
3	R/W	0	<b>EDSSI</b> Enable Modem Status Interrupt This is used to enable/disable the generation of Modem Status Interrupt. This is the fourth highest priority interrupt. 0: Disable 1: Enable
2	R/W	0	<b>ELSI</b> Enable Receiver Line Status Interrupt This is used to enable/disable the generation of Receiver Line Status Interrupt. This is the highest priority interrupt. 0: Disable 1: Enable
1	R/W	0	<b>ETBEI</b> Enable Transmit Holding Register Empty Interrupt This is used to enable/disable the generation of Transmitter Holding Register Empty Interrupt. This is the third highest priority interrupt. 0: Disable 1: Enable
0	R/W	0	<b>ERBFI</b> Enable Received Data Available Interrupt This is used to enable/disable the generation of Received Data Available Interrupt and the Character Timeout Interrupt (if in FIFO mode and FIFOs enabled). These are the second highest priority interrupts.



			0: Disable 1: Enable
--	--	--	-------------------------

**8.3.5.6. UART Interrupt Identity Register(Default Value: 0x00000000)**

Offset: 0x0008			Register Name: <b>UART_IIR</b>
Bit	R/W	Default/Hex	Description
31:8	/	/	/
7:6	R	0	FEFLAG FIFOs Enable Flag This is used to indicate whether the FIFOs are enabled or disabled. 00: Disable 11: Enable
5:4	/	/	/
3:0	R	0x1	IID Interrupt ID This indicates the highest priority pending interrupt which can be one of the following types: 0000: modem status 0001: no interrupt pending 0010: THR empty 0100: received data available 0110: receiver line status 0111: busy detect 1100: character timeout Bit 3 indicates an interrupt can only occur when the FIFOs are enabled and used to distinguish a Character Timeout condition interrupt.

Interrupt ID	Priority Level	Interrupt Type	Interrupt Source	Interrupt Reset
0001	-	None	None	-
0110	Highest	Receiver line status	Overrun/parity/ framing errors or break interrupt	Reading the line status register
0100	Second	Received data available	Receiver data available (non-FIFO mode or FIFOs disabled) or RCVR FIFO trigger level reached (FIFO mode and FIFOs enabled)	Reading the receiver buffer register (non-FIFO mode or FIFOs disabled) or the FIFO drops below the trigger level (FIFO mode and FIFOs enabled)
1100	Second	Character timeout indication	No characters in or out of the RCVR FIFO during the last 4 character times and there is at least 1 character in it during This time	Reading the receiver buffer register

0010	Third	Transmit holding register empty	Transmitter holding register empty (Program THRE Mode disabled) or XMIT FIFO at or below threshold (Program THRE Mode enabled)	Reading the IIR register (if source of interrupt); or, writing into THR (FIFOs or THRE Mode not selected or disabled) or XMIT FIFO above threshold (FIFOs and THRE Mode selected and enabled).
0000	Fourth	Modem status	Clear to send or data set ready or ring indicator or data carrier detect. Note that if auto flow control mode is enabled, a change in CTS (that is, DCTS set) does not cause an interrupt.	Reading the Modem status Register
0111	Fifth	Busy detect indication	UART_16550_COMPATIBLE = NO and master has tried to write to the Line Control Register while the UART is busy (USR[0] is set to one).	Reading the UART status register

### 8.3.5.7. UART FIFO Control Register(Default Value: 0x00000000)

Offset: 0x0008			Register Name: <b>UART_FCR</b>
Bit	R/W	Default/Hex	Description
31:8	/	/	/
7:6	W	0	<p>RT RCVR Trigger</p> <p>This is used to select the trigger level in the receiver FIFO at which the Received Data Available Interrupt is generated. In auto flow control mode it is used to determine when the rts_n signal is de-asserted. It also determines when the dma_rx_req_n signal is asserted in certain modes of operation.</p> <p>00: 1 character in the FIFO 01: FIFO ¼ full 10: FIFO ½ full 11: FIFO-2 less than full</p>
5:4	W	0	<p>TFT TX Empty Trigger</p> <p>Writes have no effect when THRE_MODE_USER = Disabled. This is used to select the empty threshold level at which the THRE Interrupts are generated when the mode is active. It also determines when the dma_tx_req_n signal is asserted when in certain modes of operation.</p> <p>00: FIFO empty 01: 2 characters in the FIFO 10: FIFO ¼ full 11: FIFO ½ full</p>
3	W	0	DMAM

			DMA Mode 0: Mode 0 1: Mode 1
2	W	0	XFIFOR XMIT FIFO Reset This resets the control portion of the transmit FIFO and treats the FIFO as empty. This also de-asserts the DMA TX request. It is 'self-clearing'. It is not necessary to clear this bit.
1	W	0	RFIFOR RCVR FIFO Reset This resets the control portion of the receive FIFO and treats the FIFO as empty. This also de-asserts the DMA RX request. It is 'self-clearing'. It is not necessary to clear this bit.
0	W	0	FIFOE Enable FIFOs This enables/disables the transmit (XMIT) and receive (RCVR) FIFOs. Whenever the value of this bit is changed both the XMIT and RCVR controller portion of FIFOs is reset.

**8.3.5.8. UART Line Control Register(Default Value: 0x00000000)**

Offset: 0x000C			Register Name: <b>UART_LCR</b>
Bit	R/W	Default/Hex	Description
31:8	/	/	/
7	R/W	0	DLAB Divisor Latch Access Bit It is writeable only when UART is not busy (USR[0] is zero) and always readable. This bit is used to enable reading and writing of the Divisor Latch register (DLL and DLH) to set the baud rate of the UART. This bit must be cleared after initial baud rate setup in order to access other registers. 0: Select RX Buffer Register (RBR) / TX Holding Register(THR) and Interrupt Enable Register (IER) 1: Select Divisor Latch LS Register (DLL) and Divisor Latch MS Register (DLM)
6	R/W	0	BC Break Control Bit This is used to cause a break condition to be transmitted to the receiving device. If set to one the serial output is forced to the spacing (logic 0) state. When not in Loopback Mode, as determined by MCR[4], the sout line is forced low until the Break bit is cleared. If SIR_MODE = Enabled and active (MCR[6] set to one) the sir_out_n line is continuously pulsed. When in Loopback Mode, the break condition is internally looped back to the receiver and the sir_out_n line is forced low.
5:4	R/W	0	EPS Even Parity Select

			<p>It is writeable only when UART is not busy (USR[0] is zero) and always writable readable. This is used to select between even and odd parity, when parity is enabled (PEN set to one). Setting the LCR[5] is to reverse the LCR[4].</p> <p>00: Odd Parity 01: Even Parity 1X: Reverse LCR[4]</p>
3	R/W	0	<p>PEN Parity Enable</p> <p>It is writeable only when UART is not busy (USR[0] is zero) and always readable. This bit is used to enable and disable parity generation and detection in transmitted and received serial character respectively.</p> <p>0: parity disabled 1: parity enabled</p>
2	R/W	0	<p>STOP Number of stop bits</p> <p>It is writeable only when UART is not busy (USR[0] is zero) and always readable. This is used to select the number of stop bits per character that the peripheral transmits and receives. If set to zero, one stop bit is transmitted in the serial data. If set to one and the data bits are set to 5 (LCR[1:0] set to zero) one and a half stop bits is transmitted. Otherwise, two stop bits are transmitted. Note that regardless of the number of stop bits selected, the receiver checks only the first stop bit.</p> <p>0: 1 stop bit 1: 1.5 stop bits when DLS (LCR[1:0]) is zero, else 2 stop bit</p>
1:0	R/W	0	<p>DLS Data Length Select</p> <p>It is writeable only when UART is not busy (USR[0] is zero) and always readable. This is used to select the number of data bits per character that the peripheral transmits and receives. The number of bit that may be selected areas follows:</p> <p>00: 5 bits 01: 6 bits 10: 7 bits 11: 8 bits</p>

### 8.3.5.9. UART Modem Control Register(Default Value: 0x00000000)

Offset: 0x0010			Register Name: <b>UART_MCR</b>
Bit	R/W	Default/Hex	Description
31:7	/	/	/
6	R/W	0	<p>SIRE SIR Mode Enable</p> <p>0:IrDA SIR Mode disabled 1:IrDA SIR Mode enabled</p>

5	R/W	0	<p>AFCE</p> <p>Auto Flow Control Enable</p> <p>When FIFOs are enabled and the Auto Flow Control Enable (AFCE) bit is set, Auto Flow Control features are enabled.</p> <p>0: Auto Flow Control Mode disabled</p> <p>1: Auto Flow Control Mode enabled</p>
4	R/W	0	<p>LOOP</p> <p>Loop Back Mode</p> <p>0: Normal Mode</p> <p>1: Loop Back Mode</p> <p>This is used to put the UART into a diagnostic mode for test purposes. If operating in UART mode (SIR_MODE != Enabled or not active, MCR[6] set to zero), data on the sout line is held high, while serial data output is looped back to the sin line, internally. In this mode all the interrupts are fully functional. Also, in loopback mode, the modem control inputs (dsr_n, cts_n, ri_n, dcd_n) are disconnected and the modem control outputs (dtr_n, rts_n, out1_n, out2_n) are looped back to the inputs, internally. If operating in infrared mode (SIR_MODE == Enabled AND active, MCR[6] set to one), data on the sir_out_n line is held low, while serial data output is inverted and looped back to the sir_in line.</p>
3:2	/	/	/
1	R/W	0	<p>RTS</p> <p>Request to Send</p> <p>This is used to directly control the Request to Send (rts_n) output. The Request To Send (rts_n) output is used to inform the modem or data set that the UART is ready to exchange data. When Auto RTS Flow Control is not enabled (MCR[5] set to zero), the rts_n signal is set low by programming MCR[1] (RTS) to a high. In Auto Flow Control, AFCE_MODE == Enabled and active (MCR[5] set to one) and FIFOs enable (FCR[0] set to one), the rts_n output is controlled in the same way, but is also gated with the receiver FIFO threshold trigger (rts_n is inactive high when above the threshold). The rts_n signal is de-asserted when MCR[1] is set low.</p> <p>0: rts_n de-asserted (logic 1)</p> <p>1: rts_n asserted (logic 0)</p> <p>Note that in Loopback mode (MCR[4] set to one), the rts_n output is held inactive high while the value of this location is internally looped back to an input.</p>
0	R/W	0	<p>DTR</p> <p>Data Terminal Ready</p> <p>This is used to directly control the Data Terminal Ready (dtr_n) output. The value written to this location is inverted and driven out on dtr_n.</p> <p>0: dtr_n de-asserted (logic 1)</p> <p>1: dtr_n asserted (logic 0)</p> <p>The Data Terminal Ready output is used to inform the modem or data set that the UART is ready to establish communications.</p>

			Note that in Loopback mode (MCR[4] set to one), the dtr_n output is held inactive high while the value of this location is internally looped back to an input.
--	--	--	--

**8.3.5.10. UART Line Status Register(Default Value: 0x0000060)**

Offset: 0x0014			Register Name: <b>UART_LSR</b>
Bit	R/W	Default/Hex	Description
31:8	/	/	/
7	R	0	<b>FIFOERR</b> RX Data Error in FIFO When FIFOs are disabled, this bit is always 0. When FIFOs are enabled, this bit is set to 1 when there is at least one PE, FE, or BI in the RX FIFO. It is cleared by a read from the LSR register provided there are no subsequent errors in the FIFO.
6	R	1	<b>TEMT</b> Transmitter Empty If the FIFOs are disabled, this bit is set to "1" whenever the TX Holding Register and the TX Shift Register are empty. If the FIFOs are enabled, this bit is set whenever the TX FIFO and the TX Shift Register are empty. In both cases, this bit is cleared when a byte is written to the TX data channel.
5	R	1	<b>THRE</b> TX Holding Register Empty If the FIFOs are disabled, this bit is set to "1" whenever the TX Holding Register is empty and ready to accept new data and it is cleared when the CPU writes to the TX Holding Register. If the FIFOs are enabled, this bit is set to "1" whenever the TX FIFO is empty and it is cleared when at least one byte is written to the TX FIFO.
4	R	0	<b>BI</b> Break Interrupt This is used to indicate the detection of a break sequence on the serial input data. It is set whenever the serial input, sin, is held in a logic '0' state for longer than the sum of start time + data bits + parity + stop bits. In the FIFO mode, the character associated with the break condition is carried through the FIFO and is revealed when the character is at the top of the FIFO. Reading the LSR clears the BI bit. In the non-FIFO mode, the BI indication occurs immediately and persists until the LSR is read.
3	R	0	<b>FE</b> Framing Error This is used to indicate the occurrence of a framing error in the receiver. A framing error occurs when the receiver does not detect a valid STOP bit in the received data.

			<p>In the FIFO mode, since the framing error is associated with a character received, it is revealed when the character with the framing error is at the top of the FIFO. When a framing error occurs, the UART tries to resynchronize. It does this by assuming that the error was due to the start bit of the next character and then continues receiving the other bit i.e. data, and/or parity and stop. It should be noted that the Framing Error (FE) bit (LSR[3]) is set if a break interrupt has occurred, as indicated by Break Interrupt (BI) bit (LSR[4]).</p> <p>0: no framing error 1: framing error</p> <p>Reading the LSR clears the FE bit.</p>
2	R	0	<p>PE Parity Error</p> <p>This is used to indicate the occurrence of a parity error in the receiver if the Parity Enable (PEN) bit (LCR[3]) is set. In the FIFO mode, since the parity error is associated with a character received, it is revealed when the character with the parity error arrives at the top of the FIFO. It should be noted that the Parity Error (PE) bit (LSR[2]) is set if a break interrupt has occurred, as indicated by Break Interrupt (BI) bit (LSR[4]).</p> <p>0: no parity error 1: parity error</p> <p>Reading the LSR clears the PE bit.</p>
1	R	0	<p>OE Overrun Error</p> <p>This occurs if a new data character was received before the previous data was read. In the non-FIFO mode, the OE bit is set when a new character arrives in the receiver before the previous character was read from the RBR. When this happens, the data in the RBR is overwritten. In the FIFO mode, an overrun error occurs when the FIFO is full and a new character arrives at the receiver. The data in the FIFO is retained and the data in the receive shift register is lost.</p> <p>0: no overrun error 1: overrun error</p> <p>Reading the LSR clears the OE bit.</p>
0	R	0	<p>DR Data Ready</p> <p>This is used to indicate that the receiver contains at least one character in the RBR or the receiver FIFO.</p> <p>0: no data ready 1: data ready</p> <p>This bit is cleared when the RBR is read in non-FIFO mode, or when the receiver FIFO is empty, in FIFO mode.</p>

**8.3.5.11. UART Modem Status Register(Default Value: 0x00000000)**

Offset: 0x0018			Register Name: <b>UART_MSR</b>
Bit	R/W	Default/Hex	Description
31:8	/	/	/
7	R	0	<p><b>DCD</b> Line State of Data Carrier Detect</p> <p>This is used to indicate the current state of the modem control line dcd_n. This bit is the complement of dcd_n. When the Data Carrier Detect input (dcd_n) is asserted it is an indication that the carrier has been detected by the modem or data set.</p> <p>0: dcd_n input is de-asserted (logic 1) 1: dcd_n input is asserted (logic 0)</p>
6	R	0	<p><b>RI</b> Line State of Ring Indicator</p> <p>This is used to indicate the current state of the modem control line ri_n. This bit is the complement of ri_n. When the Ring Indicator input (ri_n) is asserted it is an indication that a telephone ringing signal has been received by the modem or data set.</p> <p>0: ri_n input is de-asserted (logic 1) 1: ri_n input is asserted (logic 0)</p>
5	R	0	<p><b>DSR</b> Line State of Data Set Ready</p> <p>This is used to indicate the current state of the modem control line dsr_n. This bit is the complement of dsr_n. When the Data Set Ready input (dsr_n) is asserted it is an indication that the modem or data set is ready to establish communications with UART.</p> <p>0: dsr_n input is de-asserted (logic 1) 1: dsr_n input is asserted (logic 0)</p> <p>In Loopback Mode (MCR[4] set to one), DSR is the same as MCR[0] (DTR).</p>
4	R	0	<p><b>CTS</b> Line State of Clear To Send</p> <p>This is used to indicate the current state of the modem control line cts_n. This bit is the complement of cts_n. When the Clear to Send input (cts_n) is asserted it is an indication that the modem or data set is ready to exchange data with UART.</p> <p>0: cts_n input is de-asserted (logic 1) 1: cts_n input is asserted (logic 0)</p> <p>In Loopback Mode (MCR[4] = 1), CTS is the same as MCR[1] (RTS).</p>
3	R	0	<p><b>DDCD</b> Delta Data Carrier Detect</p> <p>This is used to indicate that the modem control line dcd_n has changed since the last time the MSR was read.</p> <p>0: no change on dcd_n since last read of MSR 1: change on dcd_n since last read of MSR</p>



			<p>Reading the MSR clears the DDCD bit.</p> <p>Note: If the DDCD bit is not set and the dcd_n signal is asserted (low) and a reset occurs (software or otherwise), then the DDCD bit is set when the reset is removed if the dcd_n signal remains asserted.</p>
2	R	0	<p>TERI</p> <p>Trailing Edge Ring Indicator</p> <p>This is used to indicate that a change on the input ri_n (from an active-low to an inactive-high state) has occurred since the last time the MSR was read.</p> <p>0: no change on ri_n since last read of MSR 1: change on ri_n since last read of MSR</p> <p>Reading the MSR clears the TERI bit.</p>
1	R	0	<p>DDSR</p> <p>Delta Data Set Ready</p> <p>This is used to indicate that the modem control line dsr_n has changed since the last time the MSR was read.</p> <p>0: no change on dsr_n since last read of MSR 1: change on dsr_n since last read of MSR</p> <p>Reading the MSR clears the DDSR bit. In Loopback Mode (MCR[4] = 1), DDSR reflects changes on MCR[0] (DTR).</p> <p>Note: If the DDSR bit is not set and the dsr_n signal is asserted (low) and a reset occurs (software or otherwise), then the DDSR bit is set when the reset is removed if the dsr_n signal remains asserted.</p>
0	R	0	<p>DCTS</p> <p>Delta Clear to Send</p> <p>This is used to indicate that the modem control line cts_n has changed since the last time the MSR was read.</p> <p>0: no change on ctsdsr_n since last read of MSR 1: change on ctsdsr_n since last read of MSR</p> <p>Reading the MSR clears the DCTS bit. In Loopback Mode (MCR[4] = 1), DCTS reflects changes on MCR[1] (RTS).</p> <p>Note: If the DCTS bit is not set and the cts_n signal is asserted (low) and a reset occurs (software or otherwise), then the DCTS bit is set when the reset is removed if the cts_n signal remains asserted.</p>

### 8.3.5.12. UART Scratch Register(Default Value: 0x00000000)

Offset: 0x001C			Register Name: <b>UART_SCH</b>
Bit	R/W	Default/Hex	Description
31:8	/	/	/
7:0	R/W	0	<p>SCRATCH_REG</p> <p>Scratch Register</p> <p>This register is for programmers to use as a temporary storage space. It has no defined purpose in the UART.</p>

**8.3.5.13. UART Status Register(Default Value: 0x00000006)**

Offset: 0x007C			Register Name: <b>UART_USR</b>
Bit	R/W	Default/Hex	Description
31:5	/	/	/
4	R	0	<p>RFF Receive FIFO Full This is used to indicate that the receive FIFO is completely full. 0: Receive FIFO not full 1: Receive FIFO Full This bit is cleared when the RX FIFO is no longer full.</p>
3	R	0	<p>RFNE Receive FIFO Not Empty This is used to indicate that the receive FIFO contains one or more entries. 0: Receive FIFO is empty 1: Receive FIFO is not empty This bit is cleared when the RX FIFO is empty.</p>
2	R	1	<p>TFE Transmit FIFO Empty This is used to indicate that the transmit FIFO is completely empty. 0: Transmit FIFO is not empty 1: Transmit FIFO is empty This bit is cleared when the TX FIFO is no longer empty.</p>
1	R	1	<p>TFNF Transmit FIFO Not Full This is used to indicate that the transmit FIFO is not full. 0: Transmit FIFO is full 1: Transmit FIFO is not full This bit is cleared when the TX FIFO is full.</p>
0	R	0	<p>BUSY UART Busy Bit 0: Idle or inactive 1: Busy</p>

**8.3.5.14. UART Transmit FIFO Level Register(Default Value: 0x00000000)**

Offset: 0x0080			Register Name: <b>UART_TFL</b>
Bit	R/W	Default/Hex	Description
31:7	/	/	/
6:0	R	0	<p>TFL Transmit FIFO Level This indicates the number of data entries in the transmit FIFO.</p>

**8.3.5.15. UART Receive FIFO Level Register(Default Value: 0x00000000)**

Offset: 0x0084			Register Name: <b>UART_RFL</b>
Bit	R/W	Default/Hex	Description
31:7	/	/	/
6:0	R	0	RFL Receive FIFO Level This indicates the number of data entries in the receive FIFO.

**8.3.5.16. UART Halt TX Register(Default Value: 0x00000000)**

Offset: 0x00A4			Register Name: <b>UART_HALT</b>
Bit	R/W	Default/Hex	Description
31:6	/	/	/
5	R/W	0	SIR_RX_INVERT SIR Receiver Pulse Polarity Invert 0:Not invert receiver signal 1:Invert receiver signal
4	R/W	0	SIR_TX_INVERT SIR Transmit Pulse Polarity Invert 0:Not invert transmit pulse 1:Invert transmit pulse
3	/	/	/
2	R/W	0	CHANGE_UPDATE After the user using HALT[1] to change the baudrate or LCR configuration, write 1 to update the configuration and waiting this bit self clear to 0 to finish update process. Write 0 to this bit has no effect. 1: Update trigger, Self clear to 0 when finish update.
1	R/W	0	CHCFG_AT_BUSY This is an enable bit for the user to change LCR register configuration (except for the DLAB bit) and baudrate register (DLH and DLL) when the UART is busy (USB[0] is 1). 1: Enable change when busy
0	R/W	0	HALT_TX Halt TX This register is use to halt transmissions for testing, so that the transmit FIFO can be filled by the master when FIFOs are implemented and enabled. 0 : Halt TX disabled 1 : Halt TX enabled Note: If FIFOs are not enabled, the setting of the halt TX register has no effect on operation.



## 8.4. USB

### 8.4.1. USB OTG Controller

The USB OTG controller is a Dual-Role Device which supports both device and host functions which can also be configured as a Host-only or Device-only controller, fully compliant with the USB 2.0 Specification. It can support high-speed (HS, 480-Mbps), full-speed (FS, 12-Mbps), and low-speed (LS, 1.5-Mbps) transfers in Host mode. It can support high-speed (HS, 480-Mbps), and full-speed (FS, 12-Mbps) in Device mode. Standard USB transceiver can be used through its UTMI+PHY Level3 interface. The UTMI+PHY interface is bidirectional with 8-bit data bus. For saving CPU bandwidth, USB-OTG DMA interface can support external DMA controller to take care of the data transfer between the memory and USB-OTG FIFO. The USB-OTG core also supports USB power saving functions.

The USB2.0 OTG controller has following features:

- Support Device or Host operation at a time
- Support High-Speed (HS, 480-Mbps), Full-Speed (FS, 12-Mbps), and Low-Speed (LS, 1.5-Mbps) in host mode
- Complies with Enhanced Host Controller Interface (EHCI) Specification, Version 1.0, and the Open Host Controller Interface (OHCI) Specification, Version 1.0a in host mode
- Support High-Speed (HS, 480-Mbps), Full-Speed (FS, 12-Mbps) in device mode
- Supports up to 8 User-Configurable Endpoints for Bulk , Isochronous and Interrupt bi-directional transfers (Endpoint1, Endpoint2, Endpoint3, Endpoint4, Endpoint5) in device mode
- Supports up to 4032BytesFIFO for EPs (Excluding EP0) in device mode
- Supports bi-directional endpoint0 for Control transfer in device mode
- Supports the UTMI+ Level 3 interface . The 8-bit bidirectional data buses are used
- Supports High-Bandwidth Isochronous & Interrupt transfers in device mode
- Automated splitting/combining of packets for Bulk transfers in device mode
- Supports point-to-point and point-to-multipoint transfer in both Host and Peripheral mode
- Performs all transaction scheduling in hardware
- Power Optimization and Power Management capabilities
- Supports only 1 USB Root Port shared between EHCI and OHCI

#### 8.4.1.1. Block Diagram

Figure 8-6 shows the block diagram of USB OTG Controller:

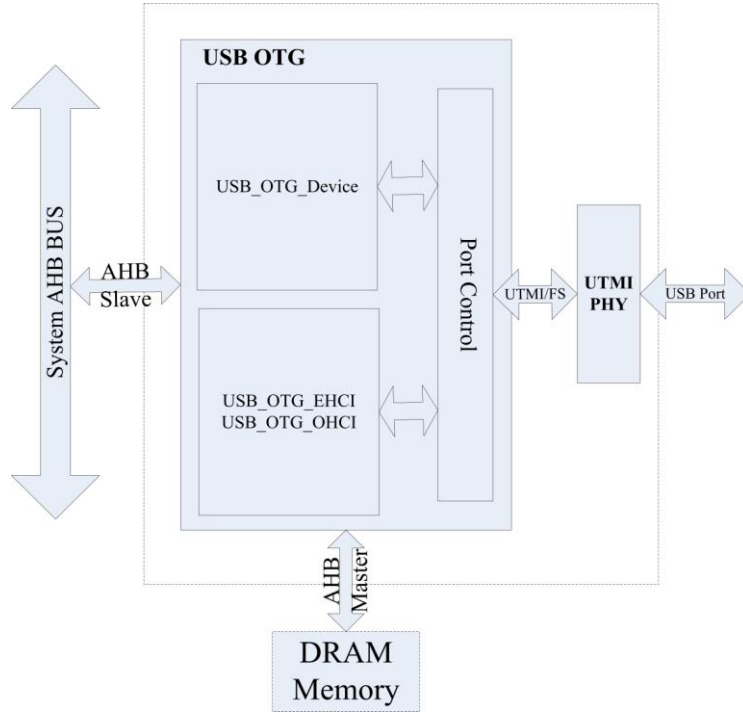

Figure 8-6. USB OTG Controller Block Diagram

8.4.1.2. USB OTG Register List

Module Name	Base Address
USB_OTG_EHCI0/OHCI0	0x01C1A000

Register Name	Offset	Description
<b>EHCI Capability Register</b>		
E_CAPLENGTH	0x000	EHCI Capability register Length Register
E_HCVERSION	0x002	EHCI Host Interface Version Number Register
E_HCSPARAMS	0x004	EHCI Host Control Structural Parameter Register
E_HCCPARAMS	0x008	EHCI Host Control Capability Parameter Register
E_HCSPPORTROUTE	0x00c	EHCI Companion Port Route Description
<b>EHCI Operational Register</b>		
E_USBCMD	0x010	EHCI USB Command Register
E_USBSTS	0x014	EHCI USB Status Register
E_USBINTR	0x018	EHCI USB Interrupt Enable Register
E_FRINDEX	0x01c	EHCI USB Frame Index Register
E_CTRLDSSEGMENT	0x020	EHCI 4G Segment Selector Register
E_PERIODICLISTBASE	0x024	EHCI Frame List Base Address Register
E_ASYNCLISTADDR	0x028	EHCI Next Asynchronous List Address Register
E_CONFIGFLAG	0x050	EHCI Configured Flag Register
E_PORTSC	0x054	EHCI Port Status/Control Register

OHCI Control and Status Partition Register		
O_HcRevision	0x400	OHCI Revision Register
O_HcControl	0x404	OHCI Control Register
O_HcCommandStatus	0x408	OHCI Command Status Register
O_HcInterruptStatus	0x40c	OHCI Interrupt Status Register
O_HcInterruptEnable	0x410	OHCI Interrupt Enable Register
O_HcInterruptDisable	0x414	OHCI Interrupt Disable Register
OHCI Memory Pointer Partition Register		
O_HcHCCA	0x418	OHCI HCCA Base
O_HcPeriodCurrentED	0x41c	OHCI Period Current ED Base
O_HcControlHeadED	0x420	OHCI Control Head ED Base
O_HcControlCurrentED	0x424	OHCI Control Current ED Base
O_HcBulkHeadED	0x428	OHCI Bulk Head ED Base
O_HcBulkCurrentED	0x42c	OHCI Bulk Current ED Base
O_HcDoneHead	0x430	OHCI Done Head Base
OHCI Frame Counter Partition Register		
O_HcFmInterval	0x434	OHCI Frame Interval Register
O_HcFmRemaining	0x438	OHCI Frame Remaining Register
O_HcFmNumber	0x43c	OHCI Frame Number Register
O_HcPeriodicStart	0x440	OHCI Periodic Start Register
O_HcLSThreshold	0x444	OHCI LS Threshold Register
OHCI Root Hub Partition Register		
O_HcRhDescriptorA	0x448	OHCI Root Hub Descriptor Register A
O_HcRhDescriptorB	0x44c	OHCI Root Hub Descriptor Register B
O_HcRhStatus	0x450	OHCI Root Hub Status Register
O_HcRhPortStatus	0x454	OHCI Root Hub Port Status Register

### 8.4.1.3. EHCI Register Description

#### 8.4.1.3.1. EHCI Identification Register(Default Value: Implementation Dependent)

Offset: 0x0000			Register Name: <b>CAPLENGTH</b>
Bit	R/W	Default/Hex	Description
7:0	R	0x10	CAPLENGTH The value in these bits indicates an offset to add to register base to find the beginning of the Operational Register Space.

#### 8.4.1.3.2. EHCI Host Interface Version Number Register(Default Value: 0x0100)

Offset: 0x0002			Register Name: <b>HCIVERSION</b>
Bit	R/W	Default/Hex	Description

15:0	R	0x0100	<b>HCIVERSION</b> This is a 16-bits register containing a BCD encoding of the EHCI revision number supported by this host controller. The most significant byte of this register represents a major revision and the least significant byte is the minor revision.
------	---	--------	---

**8.4.1.3.3. EHCI Host Control Structural Parameter Register(Default Value: Implementation Dependent)**

Offset: 0x0004			Register Name: <b>HCSPARAMS</b>						
Bit	R/W	Default/Hex	Description						
31:24	/	0	Reserved. These bits are reserved and should be set to zero.						
23:20	R	0	<b>Debug Port Number</b> This register identifies which of the host controller ports is the debug port. The value is the port number (one based) of the debug port. This field will always be '0'.						
19:16	/	0	Reserved. These bits are reserved and should be set to zero.						
15:12	R	0	<b>Number of Companion Controller (N_CC)</b> This field indicates the number of companion controllers associated with this USB2.0 host controller. A zero in this field indicates there are no companion host controllers. And a value larger than zero in this field indicates there are companion USB1.1 host controller(s). This field will always be '0'.						
11:8	R	0	<b>Number of Port per Companion Controller(N_PCC)</b> This field indicates the number of ports supported per companion host controller host controller. It is used to indicate the port routing configuration to system software. This field will always fix with '0'.						
7	R	0	<b>Port Routing Rules</b> This field indicates the method used by this implementation for how all ports are mapped to companion controllers. The value of this field has the following interpretation: <table border="1" data-bbox="593 1626 1390 1921" style="margin-left: 20px;"> <thead> <tr> <th>Value</th> <th>Meaning</th> </tr> </thead> <tbody> <tr> <td>0</td> <td>The first N_PCC ports are routed to the lowest numbered function companion host controller, the next N_PCC port are routed to the next lowest function companion controller, and so on.</td> </tr> <tr> <td>1</td> <td>The port routing is explicitly enumerated by the first N_PORTS elements of the HCSP-PORTROUTE array.</td> </tr> </tbody> </table> This field will always be '0'.	Value	Meaning	0	The first N_PCC ports are routed to the lowest numbered function companion host controller, the next N_PCC port are routed to the next lowest function companion controller, and so on.	1	The port routing is explicitly enumerated by the first N_PORTS elements of the HCSP-PORTROUTE array.
Value	Meaning								
0	The first N_PCC ports are routed to the lowest numbered function companion host controller, the next N_PCC port are routed to the next lowest function companion controller, and so on.								
1	The port routing is explicitly enumerated by the first N_PORTS elements of the HCSP-PORTROUTE array.								
6:4	/	0	Reserved. These bits are reserved and should be set to zero.						



3:0	R	1	<p><b>N_PORTS</b> This field specifies the number of physical downstream ports implemented on this host controller. The value of this field determines how many port registers are addressable in the Operational Register Space. Valid values are in the range of 0x1 to 0x0f.</p> <p>This field is always 1.</p>
-----	---	---	--

**8.4.1.3.4. EHCI Host Control Capability Parameter Register(Default Value: Implementation Dependent)**

Offset: 0x0008			Register Name: <b>HCCPARAMS</b>
Bit	R/W	Default/Hex	Description
31:16	/	0	<p>Reserved</p> <p>These bits are reserved and should be set to zero.</p>
15:18	R	0	<p><b>EHCI Extended Capabilities Pointer (EECP)</b> This optional field indicates the existence of a capabilities list. A value of 00b indicates no extended capabilities are implemented. A non-zero value in this register indicates the offset in PCI configuration space of the first EHCI extended capability. The pointer value must be 40h or greater if implemented to maintain consistency of the PCI header defined for this class of device.</p> <p>The value of this field is always '00b'.</p>
7:4	R		<p><b>Isochronous Scheduling Threshold</b> This field indicates, relative to the current position of the executing host controller, where software can reliably update the isochronous schedule. When bit[7] is zero, the value of the least significant 3 bits indicates the number of micro-frames a host controller can hold a set of isochronous data structures(one or more) before flushing the state. When bit[7] is a one, then host software assumes the host controller may cache an isochronous data structure for an entire frame.</p>
3	R	0	<p>Reserved</p> <p>These bits are reserved and should be set to zero.</p>
2	R		<p><b>Asynchronous Schedule Park Capability</b> If this bit is set to a one, then the host controller supports the park feature for high-speed queue heads in the Asynchronous Schedule. The feature can be disabled or enabled and set to a specific level by using the Asynchronous Schedule Park Mode Enable and Asynchronous Schedule Park Mode Count fields in the USB_CMD register.</p>
1	R		<p><b>Programmable Frame List Flag</b> If this bit is set to a zero, then system software must use a frame list length of 1024 elements with this host controller. The USB_CMD register Frame List Size field is a read-only register and should be set to zero. If set to 1, then system software can specify and use the frame list in the USB_CMD register Frame List Size field to configure the host controller. The frame list must always aligned on a 4K page boundary. This requirement</p>

			ensures that the frame list is always physically contiguous.
0	R	0	Reserved These bits are reserved for future use and should return a value of zero when read.

**8.4.1.3.5. EHCI Companion Port Route Description (Default Value: UNDEFINED)**

Offset: 0x000C			Register Name: <b>HCSP-PORTROUTE</b>
Bit	R/W	Default/Hex	Description
31:0	R		<p>HCSP-PORTROUTE</p> <p>This optional field is valid only if Port Routing Rules field in HCSPARAMS register is set to a one.</p> <p>This field is used to allow a host controller implementation to explicitly describe to which companion host controller each implemented port is mapped. This field is a 15-element nibble array (each 4 bit is one array element). Each array location corresponds one-to-one with a physical port provided by the host controller (e.g. PORTROUTE [0] corresponds to the first PORTSC port, PORTROUTE [1] to the second PORTSC port, etc.). The value of each element indicates to which of the companion host controllers this port is routed. Only the first N_PORTS elements have valid information. A value of zero indicates that the port is routed to the lowest numbered function companion host controller. A value of one indicates that the port is routed to the next lowest numbered function companion host controller, and so on.</p>

**8.4.1.3.6. EHCI USB Command Register (Default Value: 0x00080000(0x00080B00 if Asynchronous Schedule Park Capability is a one))**

Offset: 0x0010			Register Name: <b>USBCMD</b>														
Bit	R/W	Default/Hex	Description														
31:24	/	0	Reserved These bits are reserved and should be set to zero.														
23:16	R/W	0x08	<p>Interrupt Threshold Control</p> <p>The value in this field is used by system software to select the maximum rate at which the host controller will issue interrupts. The only valid values are defined below:</p> <table border="1" style="margin-left: 20px;"> <thead> <tr> <th>Value</th> <th>Minimum Interrupt Interval</th> </tr> </thead> <tbody> <tr> <td>0x00</td> <td>Reserved</td> </tr> <tr> <td>0x01</td> <td>1 micro-frame</td> </tr> <tr> <td>0x02</td> <td>2 micro-frame</td> </tr> <tr> <td>0x04</td> <td>4 micro-frame</td> </tr> <tr> <td>0x08</td> <td>8 micro-frame(default, equates to 1 ms)</td> </tr> <tr> <td>0x10</td> <td>16 micro-frame(2ms)</td> </tr> </tbody> </table>	Value	Minimum Interrupt Interval	0x00	Reserved	0x01	1 micro-frame	0x02	2 micro-frame	0x04	4 micro-frame	0x08	8 micro-frame(default, equates to 1 ms)	0x10	16 micro-frame(2ms)
Value	Minimum Interrupt Interval																
0x00	Reserved																
0x01	1 micro-frame																
0x02	2 micro-frame																
0x04	4 micro-frame																
0x08	8 micro-frame(default, equates to 1 ms)																
0x10	16 micro-frame(2ms)																

			<table border="1"> <tr> <td>0x20</td> <td>32 micro-frame(4ms)</td> </tr> <tr> <td>0x40</td> <td>64 micro-frame(8ms)</td> </tr> </table> <p>Any other value in this register yields undefined results. The default value in this field is 0x08 . Software modifications to this bit while HC Halted bit is equal to zero results in undefined behavior.</p>	0x20	32 micro-frame(4ms)	0x40	64 micro-frame(8ms)
0x20	32 micro-frame(4ms)						
0x40	64 micro-frame(8ms)						
15:12	/	0	<p>Reserved</p> <p>These bits are reserved and should be set to zero.</p>				
11	R/W or R	0	<p>Asynchronous Schedule Park Mode Enable(OPTIONAL)</p> <p>If the Asynchronous Park Capability bit in the HCCPARAMS register is a one, then this bit defaults to a 1 and is R/W. Otherwise the bit must be a zero and is Read Only. Software uses this bit to enable or disable Park mode. When this bit is one, Park mode is enabled. When this bit is zero, Park mode is disabled.</p>				
10	/	0	<p>Reserved</p> <p>These bits are reserved and should be set to zero.</p>				
9:8	R/W or R	0	<p>Asynchronous Schedule Park Mode Count(OPTIONAL)</p> <p>Asynchronous Park Capability bit in the HCCPARAMS register is a one, Then this field defaults to 0x3 and is W/R. Otherwise it defaults to zero and is R. It contains a count of the number of successive transactions the host controller is allowed to execute from a high-speed queue head on the Asynchronous schedule before continuing traversal of the Asynchronous schedule.</p> <p>Valid value are 0x1 to 0x3. Software must not write a zero to this bit when Park Mode Enable is a one as it will result in undefined behavior.</p>				
7	R/W	0	<p>Light Host Controller Reset(OPTIONAL)</p> <p>This control bit is not required.</p> <p>If implemented, it allows the driver to reset the EHCI controller without affecting the state of the ports or relationship to the companion host controllers. For example, the PORSTC registers should not be reset to their default values and the CF bit setting should not go to zero (retaining port ownership relationships).</p> <p>A host software read of this bit as zero indicates the Light Host Controller Reset has completed and it is safe for software to re-initialize the host controller. A host software read of this bit as a one indicates the Light Host</p>				
6	R/W	0	<p>Interrupt on Async Advance Doorbell</p> <p>This bit is used as a doorbell by software to tell the host controller to issue an interrupt the next time it advances asynchronous schedule. Software must write a 1 to this bit to ring the doorbell.</p> <p>When the host controller has evicted all appropriate cached schedule state, it sets the Interrupt on Async Advance status bit in the USBSTS. if the Interrupt on Async Advance Enable bit in the USBINTR register is a one then the host controller will assert an interrupt at the next interrupt threshold.</p> <p>The host controller sets this bit to a zero after it has set the Interrupt on Async Advance status bit in the USBSTS register to a one.</p>				

			Software should not write a one to this bit when the asynchronous schedule is disabled. Doing so will yield undefined results.										
5	R/W	0	<p>Asynchronous Schedule Enable</p> <p>This bit controls whether the host controller skips processing the Asynchronous Schedule. Values mean:</p> <table border="1"> <thead> <tr> <th>Bit Value</th> <th>Meaning</th> </tr> </thead> <tbody> <tr> <td>0</td> <td>Do not process the Asynchronous Schedule.</td> </tr> <tr> <td>1</td> <td>Use the ASYNLISTADDR register to access the Asynchronous Schedule.</td> </tr> </tbody> </table> <p>The default value of this field is '0b'.</p>	Bit Value	Meaning	0	Do not process the Asynchronous Schedule.	1	Use the ASYNLISTADDR register to access the Asynchronous Schedule.				
Bit Value	Meaning												
0	Do not process the Asynchronous Schedule.												
1	Use the ASYNLISTADDR register to access the Asynchronous Schedule.												
4	R/W	0	<p>Periodic Schedule Enable</p> <p>This bit controls whether the host controller skips processing the Periodic Schedule. Values mean:</p> <table border="1"> <thead> <tr> <th>Bit Value</th> <th>Meaning</th> </tr> </thead> <tbody> <tr> <td>0</td> <td>Do not process the Periodic Schedule.</td> </tr> <tr> <td>1</td> <td>Use the PERIODICLISTBASE register to access the Periodic Schedule.</td> </tr> </tbody> </table> <p>The default value of this field is '0b'.</p>	Bit Value	Meaning	0	Do not process the Periodic Schedule.	1	Use the PERIODICLISTBASE register to access the Periodic Schedule.				
Bit Value	Meaning												
0	Do not process the Periodic Schedule.												
1	Use the PERIODICLISTBASE register to access the Periodic Schedule.												
3:2	R/W or R	0	<p>Frame List Size</p> <p>This field is R/W only if Programmable Frame List Flag in the HCCPARAMS registers is set to a one. This field specifies the size of the Frame list. The size the frame list controls which bits in the Frame Index Register should be used for the Frame List Current index. Values mean:</p> <table border="1"> <thead> <tr> <th>Bits</th> <th>Meaning</th> </tr> </thead> <tbody> <tr> <td>00b</td> <td>1024 elements(4096bytes)Default value</td> </tr> <tr> <td>01b</td> <td>512 elements(2048byts)</td> </tr> <tr> <td>10b</td> <td>256 elements(1024bytes)For resource-constrained condition</td> </tr> <tr> <td>11b</td> <td>reserved</td> </tr> </tbody> </table> <p>The default value is '00b'.</p>	Bits	Meaning	00b	1024 elements(4096bytes)Default value	01b	512 elements(2048byts)	10b	256 elements(1024bytes)For resource-constrained condition	11b	reserved
Bits	Meaning												
00b	1024 elements(4096bytes)Default value												
01b	512 elements(2048byts)												
10b	256 elements(1024bytes)For resource-constrained condition												
11b	reserved												
1	R/W	0	<p>Host Controller Reset</p> <p>This control bit is used by software to reset the host controller. The effects of this on Root Hub registers are similar to a Chip Hardware Reset.</p> <p>When software writes a one to this bit, the Host Controller resets its internal pipelines, timers, counters, state machines, etc. to their initial value. Any transaction currently in progress on USB is immediately terminated. A USB reset is not driven on downstream ports.</p> <p>All operational registers, including port registers and port state machines are set to their initial values. Port ownership reverts to the companion host controller(s). Software must reinitialize the host controller as described in Section 4.1 of the CHEI Specification in order to return the host controller to an operational state.</p> <p>This bit is set to zero by the Host Controller when the reset process is complete. Software cannot terminate the reset process early by writing a zero to this register.</p>										

			Software should not set this bit to a one when the HC Halted bit in the USBSTS register is a zero. Attempting to reset an actively running host controller will result in undefined behavior.
0	R/W	0	<p><b>Run/Stop</b> When set to a 1, the Host Controller proceeds with execution of the schedule. When set to 0, the Host Controller completes the current and any actively pipelined transactions on the USB and then halts. The Host Controller must halt within 16 micro-frames after software clears this bit. The HC Halted bit indicates when the Host Controller has finished its pending pipelined transactions and has entered the stopped state. Software must not write a one to this field unless the Host Controller is in the Halt State. The default value is 0x0.</p>

#### 8.4.1.3.7. EHCI USB Status Register (Default Value: 0x00001000)

Offset: 0x0014			Register Name: <b>USBSTS</b>
Bit	R/W	Default/Hex	Description
31:16	/	0	<p><b>Reserved</b> These bits are reserved and should be set to zero.</p>
15	R	0	<p><b>Asynchronous Schedule Status</b> The bit reports the current real status of Asynchronous Schedule. If this bit is a zero then the status of the Asynchronous Schedule is disabled. If this bit is a one then the status of the Asynchronous Schedule is enabled. The Host Controller is not required to immediately disable or enable the Asynchronous Schedule when software transitions the Asynchronous Schedule Enable bit in the USBCMD register. When this bit and the Asynchronous Schedule Enable bit are the same value, the Asynchronous Schedule is either enabled (1) or disabled (0).</p>
14	R	0	<p><b>Periodic Schedule Status</b> The bit reports the current real status of the Periodic Schedule. If this bit is a zero then the status of the Periodic Schedule is disabled. If this bit is a one then the status of the Periodic Schedule is enabled. The Host Controller is not required to immediately disable or enable the Periodic Schedule when software transitions the Periodic Schedule Enable bit in the USBCMD register. When this bit and the Periodic Schedule Enable bit are the same value, the Periodic Schedule is either enabled (1) or disabled (0).</p>
13	R	0	<p><b>Reclamation</b> This is a read-only status bit, which is used to detect an empty asynchronous schedule.</p>
12	R	1	<p><b>HC Halted</b> This bit is a zero whenever the Run/Stop bit is a one. The Host Controller Sets this bit to one after it has stopped executing as a result of the Run/Stop bit being set to 0, either by software or by the Host Controller Hardware</p>

			(e.g. internal error). The default value is '1'.
11:6	/	0	Reserved These bits are reserved and should be set to zero.
5	R/WC	0	Interrupt on Async Advance System software can force the host controller to issue an interrupt the next time the host controller advances the asynchronous schedule by writing a one to the Interrupt on Async Advance Doorbell bit in the USBCMD register. This status bit indicates the assertion of that interrupt source.
4	R/WC	0	Host System Error The Host Controller set this bit to 1 when a serious error occurs during a host system access involving the Host Controller module. When this error occurs, the Host Controller clears the Run/Stop bit in the Command register to prevent further execution of the scheduled TDs.
3	R/WC	0	Frame List Rollover The Host Controller sets this bit to a one when the Frame List Index rolls over from its maximum value to zero. The exact value at which the rollover occurs depends on the frame list size. For example, if the frame list size is 1024, the Frame Index Register rolls over every time FRINDEX [13] toggles. Similarly, if the size is 512, the Host Controller sets this bit to a one every time FRINDEX [12] toggles.
2	R/WC	0	Port Change Detect The Host Controller sets this bit to a one when any port for which the Port Owner bit is set to zero has a change bit transition from a zero to a one or a Force Port Resume bit transition from a zero to a one as a result of a J-K transition detected on a suspended port. This bit will also be set as a result of the Connect Status Chang being set to a one after system software has relinquished ownership of a connected port by writing a one to a port's Port Owner bit.
1	R/WC	0	USB Error Interrupt(USBERRINT) The Host Controller sets this bit to 1 when completion of USB transaction results in an error condition(e.g. error counter underflow).If the TD on which the error interrupt occurred also had its IOC bit set, both. This bit and USBINT bit are set.
0	R/WC	0	USB Interrupt(USBINT) The Host Controller sets this bit to a one on the completion of a USB transaction, which results in the retirement of a Transfer Descriptor that had its IOC bit set. The Host Controller also sets this bit to 1 when a short packet is detected (actual number of bytes received was less than the expected number of bytes)

**8.4.1.3.8. EHCI USB Interrupt Enable Register (Default Value: 0x00000000)**

Offset: 0x0018			Register Name: <b>USBINTR</b>
Bit	R/W	Default/Hex	Description
31:6	/	0	Reserved These bits are reserved and should be zero.
5	R/W	0	Interrupt on Async Advance Enable When this bit is 1, and the Interrupt on Async Advance bit in the USBSTS register is 1, the host controller will issue an interrupt at the next interrupt threshold. The interrupt is acknowledged by software clearing the Interrupt on Async Advance bit.
4	R/W	0	Host System Error Enable When this bit is 1, and the Host System Error Status bit in the USBSTS register is 1, the host controller will issue an interrupt. The interrupt is acknowledged by software clearing the Host System Error bit.
3	R/W	0	Frame List Rollover Enable When this bit is 1, and the Frame List Rollover bit in the USBSTS register is 1, the host controller will issue an interrupt. The interrupt is acknowledged by software clearing the Frame List Rollover bit.
2	R/W	0	Port Change Interrupt Enable When this bit is 1, and the Port Chang Detect bit in the USBSTS register is 1, the host controller will issue an interrupt. The interrupt is acknowledged by software clearing the Port Chang Detect bit.
1	R/W	0	USB Error Interrupt Enable When this bit is 1, and the USBERRINT bit in the USBSTS register is 1, the host controller will issue an interrupt at the next interrupt threshold. The interrupt is acknowledged by software clearing the USBERRINT bit.
0	R/W	0	USB Interrupt Enable When this bit is 1, and the USBINT bit in the USBSTS register is 1, the host controller will issue an interrupt at the next interrupt threshold. The interrupt is acknowledged by software clearing the USBINT bit

**8.4.1.3.9. EHCI Frame Index Register (Default Value: 0x00000000)**

Offset: 0x001C			Register Name: <b>FRINDEX</b>
Bit	R/W	Default/Hex	Description
31:14	/	0	Reserved These bits are reserved and should be zero.
13:0	R/W	0	Frame Index The value in this register increment at the end of each time frame (e.g. micro-frame). Bits[N:3] are used for the Frame List current index. It Means that each location of the frame list is accessed 8 times(frames or Micro-frames) before moving to the next index. The following illustrates

			Values of N based on the value of the Frame List Size field in the USBCMD register.															
			<table border="1"> <thead> <tr> <th>USBCMD[Frame List Size]</th> <th>Number Elements</th> <th>N</th> </tr> </thead> <tbody> <tr> <td>00b</td> <td>1024</td> <td>12</td> </tr> <tr> <td>01b</td> <td>512</td> <td>11</td> </tr> <tr> <td>10b</td> <td>256</td> <td>10</td> </tr> <tr> <td>11b</td> <td>Reserved</td> <td></td> </tr> </tbody> </table>	USBCMD[Frame List Size]	Number Elements	N	00b	1024	12	01b	512	11	10b	256	10	11b	Reserved	
USBCMD[Frame List Size]	Number Elements	N																
00b	1024	12																
01b	512	11																
10b	256	10																
11b	Reserved																	

**Note:** This register must be written as a DWord. Byte writes produce undefined results.

**8.4.1.3.10. EHCI Periodic Frame List Base Address Register (Default Value: Undefined)**

Offset: 0x0024			Register Name: <b>PERIODICLISTBASE</b>
Bit	R/W	Default/Hex	Description
31:12	R/W		<p>Base Address</p> <p>These bits correspond to memory address signals [31:12], respectively. This register contains the beginning address of the Periodic Frame List in the system memory.</p> <p>System software loads this register prior to starting the schedule execution by the Host Controller. The memory structure referenced by this physical memory pointer is assumed to be 4-K byte aligned. The contents of this register are combined with the Frame Index Register (FRINDEX) to enable the Host Controller to step through the Periodic Frame List in sequence.</p>
11:0	/		<p>Reserved</p> <p>Must be written as 0x0 during runtime, the values of these bits are undefined.</p>

**Note:** Writes must be Dword Writes.

**8.4.1.3.11. EHCI Current Asynchronous List Address Register (Default Value: Undefined)**

Offset: 0x0028			Register Name: <b>ASYNCLISTADDR</b>
Bit	R/W	Default/Hex	Description
31:5	R/W		<p>Link Pointer (LP)</p> <p>This field contains the address of the next asynchronous queue head to be executed.</p> <p>These bits correspond to memory address signals [31:5], respectively.</p>
4:0	/	/	<p>Reserved</p> <p>These bits are reserved and their value has no effect on operation. Bits in this field cannot be modified by system software and will always return a zero when read.</p>

**Note:** Write must be DWord Writes.



**8.4.1.3.12. EHCI Configure Flag Register (Default Value: 0x00000000)**

Offset: 0x0050			Register Name: <b>CONFIGFLAG</b>						
Bit	R/W	Default/Hex	Description						
31:1	/	0	Reserved These bits are reserved and should be set to zero.						
0	R/W	0	Configure Flag(CF) Host software sets this bit as the last action in its process of configuring the Host Controller. This bit controls the default port-routing control logic as follow: <table border="1" style="margin-left: 20px;"> <thead> <tr> <th>Value</th> <th>Meaning</th> </tr> </thead> <tbody> <tr> <td>0</td> <td>Port routing control logic default-routs each port to an implementation dependent classic host controller.</td> </tr> <tr> <td>1</td> <td>Port routing control logic default-routs all ports to this host controller.</td> </tr> </tbody> </table>	Value	Meaning	0	Port routing control logic default-routs each port to an implementation dependent classic host controller.	1	Port routing control logic default-routs all ports to this host controller.
			Value	Meaning					
0	Port routing control logic default-routs each port to an implementation dependent classic host controller.								
1	Port routing control logic default-routs all ports to this host controller.								
			The default value of this field is '0'.						

**Note:** This register is not use in the normal implementation.

**8.4.1.3.13. EHCI Port Status and Control Register (Default Value: 0x00002000(w/PPC set to one);0x00003000**

**(w/PPC set to a zero))**

Offset: 0x0054			Register Name: <b>PORTSC</b>				
Bit	R/W	Default/Hex	Description				
31:22	/	0	Reserved These bits are reserved for future use and should return a value of zero when read.				
21	R/W	0	Wake on Disconnect Enable(WKDSCNNT_E) Writing this bit to a one enables the port to be sensitive to device disconnects as wake-up events. This field is zero if Port Power is zero. The default value in this field is '0'.				
20	R/W	0	Wake on Connect Enable(WKCNNT_E) Writing this bit to a one enable the port to be sensitive to device connects as wake-up events. This field is zero if Port Power is zero. The default value in this field is '0'.				
19:16	R/W	0	Port Test Control The value in this field specifies the test mode of the port. The encoding of the test mode bits are as follow: <table border="1" style="margin-left: 20px;"> <thead> <tr> <th>Bits</th> <th>Test Mode</th> </tr> </thead> <tbody> <tr> <td>0000b</td> <td>The port is NOT operating in a test mode.</td> </tr> </tbody> </table>	Bits	Test Mode	0000b	The port is NOT operating in a test mode.
			Bits	Test Mode			
0000b	The port is NOT operating in a test mode.						

			<table border="1"> <tr> <td>0001b</td> <td>Test J_STATE</td> </tr> <tr> <td>0010b</td> <td>Test K_STATE</td> </tr> <tr> <td>0011b</td> <td>Test SEO_NAK</td> </tr> <tr> <td>0100b</td> <td>Test Packet</td> </tr> <tr> <td>0101b</td> <td>Test FORCE_ENABLE</td> </tr> <tr> <td>0110b - 1111b</td> <td>Reserved</td> </tr> </table> <p>The default value in this field is '0000b'.</p>	0001b	Test J_STATE	0010b	Test K_STATE	0011b	Test SEO_NAK	0100b	Test Packet	0101b	Test FORCE_ENABLE	0110b - 1111b	Reserved			
0001b	Test J_STATE																	
0010b	Test K_STATE																	
0011b	Test SEO_NAK																	
0100b	Test Packet																	
0101b	Test FORCE_ENABLE																	
0110b - 1111b	Reserved																	
15:14	R/W	0	<p>Reserved</p> <p>These bits are reserved for future use and should return a value of zero when read.</p>															
13	R/W	1	<p>Port Owner</p> <p>This bit unconditionally goes to a 0b when the Configured bit in the CONFIGFLAG register makes a 0b to 1b transition. This bit unconditionally goes to 1b whenever the Configured bit is zero.</p> <p>System software uses this field to release ownership of the port to selected host controller (in the event that the attached device is not a high-speed device). Software writes a one to this bit when the attached device is not a high-speed device. A one in this bit means that a companion host controller owns and controls the port.</p> <p>Default Value = 1b.</p>															
12	/	0	<p>Reserved</p> <p>These bits are reserved for future use and should return a value of zero when read.</p>															
11:10	R	0	<p>Line Status</p> <p>These bits reflect the current logical levels of the D+ (bit11) and D-(bit10) signal lines. These bits are used for detection of low-speed USB devices prior to port reset and enable sequence. This read only field is valid only when the port enable bit is zero and the current connect status bit is set to a one. The encoding of the bits are:</p> <table border="1"> <thead> <tr> <th>Bit[11:10]</th> <th>USB State</th> <th>Interpretation</th> </tr> </thead> <tbody> <tr> <td>00b</td> <td>SEO</td> <td>Not Low-speed device, perform EHCI reset.</td> </tr> <tr> <td>10b</td> <td>J-state</td> <td>Not Low-speed device, perform EHCI reset.</td> </tr> <tr> <td>01b</td> <td>K-state</td> <td>Low-speed device, release ownership of port.</td> </tr> <tr> <td>11b</td> <td>Undefined</td> <td>Not Low-speed device, perform EHCI reset.</td> </tr> </tbody> </table> <p>This value of this field is undefined if Port Power is zero.</p>	Bit[11:10]	USB State	Interpretation	00b	SEO	Not Low-speed device, perform EHCI reset.	10b	J-state	Not Low-speed device, perform EHCI reset.	01b	K-state	Low-speed device, release ownership of port.	11b	Undefined	Not Low-speed device, perform EHCI reset.
Bit[11:10]	USB State	Interpretation																
00b	SEO	Not Low-speed device, perform EHCI reset.																
10b	J-state	Not Low-speed device, perform EHCI reset.																
01b	K-state	Low-speed device, release ownership of port.																
11b	Undefined	Not Low-speed device, perform EHCI reset.																
9	/	0	<p>Reserved</p> <p>This bit is reserved for future use, and should return a value of zero when read.</p>															
8	R/W	0	<p>Port Reset</p>															

			<p>1=Port is in Reset. 0=Port is not in Reset. Default value = 0.</p> <p>When software writes a one to this bit (from a zero), the bus reset sequence as defined in the USB Specification Revision 2.0 is started. Software writes a zero to this bit to terminate the bus reset sequence. Software must keep this bit at a one long enough to ensure the reset sequence, as specified in the USB Specification Revision 2.0, completes. Notes: when software writes this bit to a one , it must also write a zero to the Port Enable bit.</p> <p>Note that when software writes a zero to this bit there may be a delay before the bit status changes to a zero. The bit status will not read as a zero until after the reset has completed. If the port is in high-speed mode after reset is complete, the host controller will automatically enable this port (e.g. set the Port Enable bit to a one). A host controller must terminate the reset and stabilize the state of the port within 2 milliseconds of software transitioning this bit from a one to a zero. For example: if the port detects that the attached device is high-speed during reset, then the host controller must have the port in the enabled state with 2ms of software writing this bit to a zero.</p> <p>The HC Halted bit in the USBSTS register should be a zero before software attempts to use this bit. The host controller may hold Port Reset asserted to a one when the HC Halted bit is a one.</p> <p>This field is zero if Port Power is zero.</p>								
7	R/W	0	<p>Suspend</p> <p>Port Enabled Bit and Suspend bit of this register define the port states as follows:</p> <table border="1" data-bbox="593 1182 1415 1361"> <thead> <tr> <th>Bits[Port Enables, Suspend]</th> <th>Port State</th> </tr> </thead> <tbody> <tr> <td>0x</td> <td>Disable</td> </tr> <tr> <td>10</td> <td>Enable</td> </tr> <tr> <td>11</td> <td>Suspend</td> </tr> </tbody> </table> <p>When in suspend state, downstream propagation of data is blocked on this port, except for port reset. The blocking occurs at the end of the current transaction, if a transaction was in progress when this bit was written to 1. In the suspend state, the port is sensitive to resume detection. Not that the bit status does not change until the port is suspend and that there may be a delay in suspending a port if there is a transaction currently in progress on the USB.</p> <p>A write of zero to this bit is ignored by the host controller. The host controller will unconditionally set this bit to a zero when:</p> <ol style="list-style-type: none"> <li>① Software sets the Force Port Resume bit to a zero(from a one).</li> <li>② Software sets the Port Reset bit to a one(from a zero).</li> </ol> <p>If host software sets this bit to a one when the port is not enabled(i.e. Port enabled bit is a zero), the results are undefined.</p> <p>This field is zero if Port Power is zero.</p> <p>The default value in this field is '0'.</p>	Bits[Port Enables, Suspend]	Port State	0x	Disable	10	Enable	11	Suspend
Bits[Port Enables, Suspend]	Port State										
0x	Disable										
10	Enable										
11	Suspend										
6	R/W	0	<p>Force Port Resume</p> <p>1 = Resume detected/driven on port. 0 = No resume (K-state) detected/</p>								

			<p>driven on port. Default value = 0.</p> <p>This functionality defined for manipulating this bit depends on the value of the Suspend bit. For example, if the port is not suspend and software transitions this bit to a one, then the effects on the bus are undefined. Software sets this bit to a 1 drive resume signaling. The Host Controller sets this bit to a 1 if a J-to-K transition is detected while the port is in the Suspend state. When this bit transitions to a one because a J-to-K transition is detected, the Port Change Detect bit in the USBSTS register is also set to a one. If software sets this bit to a one, the host controller must not set the Port Change Detect bit.</p> <p>Note that when the EHCI controller owns the port, the resume sequence follows the defined sequence documented in the USB Specification Revision 2.0. The resume signaling (Full-speed 'K') is driven on the port as long as this remains a one. Software must appropriately time the Resume and set this bit to a zero when the appropriate amount of time has elapsed. Writing a zero (from one) causes the port to return high-speed mode (forcing the bus below the port into a high-speed idle). This bit will remain a one until the port has switched to high-speed idle. The host controller must complete this transition within 2 milliseconds of software setting this bit to a zero.</p> <p>This field is zero if Port Power is zero.</p>
5	R/WC	0	<p>Over-current Change</p> <p>Default = 0. This bit gets set to a one when there is a change to Over-current Active. Software clears this bit by writing a one to this bit position.</p>
4	R	0	<p>Over-current Active</p> <p>0 = This port does not have an over-current condition. 1 = This port currently has an over-current condition. This bit will automatically transition from a one to a zero when the over current condition is removed.</p> <p>The default value of this bit is '0'.</p>
3	R/WC	0	<p>Port Enable/Disable Change</p> <p>Default = 0. 1 = Port enabled/disabled status has changed. 0 = No change. For the root hub, this bit gets set to a one only when a port is disabled due to the appropriate conditions existing at the EOF2 point (See Chapter 11 of the USB Specification for the definition of a Port Error). Software clears this bit by writing a 1 to it.</p> <p>This field is zero if Port Power is zero.</p>
2	R/W	0	<p>Port Enabled/Disabled</p> <p>1=Enable, 0=Disable. Ports can only be enabled by the host controller as a part of the reset and enable. Software cannot enable a port by writing a one to this field. The host controller will only set this bit to a one when the reset sequence determines that the attached device is a high-speed device.</p> <p>Ports can be disabled by either a fault condition(disconnect event or other fault condition) or by host software. Note that the bit status does not change until the port state actually changes. There may be a delay in disabling or enabling a port due to other host controller and bus events.</p> <p>When the port is disabled, downstream propagation of data is blocked on</p>

			<p>this port except for reset. The default value of this field is '0'. This field is zero if Port Power is zero.</p>
1	R/WC	0	<p>Connect Status Change 1=Change in Current Connect Status, 0=No change, Default=0. Indicates a change has occurred in the port's Current Connect Status. The host controller sets this bit for all changes to the port device connect status, even if system software has not cleared an existing connect status change. For example, the insertion status changes twice before system software has cleared the changed condition, hub hardware will be "setting" an already-set bit. Software sets this bit to 0 by writing a 1 to it. This field is zero if Port Power is zero.</p>
0	R	0	<p>Current Connect Status Device is present on port when the value of this field is a one, and no device is present on port when the value of this field is a zero. This value reflects the current state of the port, and may not correspond directly to the event that caused the Connect Status Change(Bit 1) to be set. This field is zero if Port Power zero.</p>

**Note:** This register is only reset by hardware or in response to a host controller reset.

#### 8.4.1.4. OHCI Register Description

##### 8.4.1.4.1. HcRevision Register(Default Value: 0x00000010)

Offset: 0x400				Register Name: <b>HcRevision</b>
Bit	Read/Write		Default/HEX	Description
	HCD	HC		
31:8	/	/	0x00	Reserved
7:0	R	R	0x10	<p>Revision This read-only field contains the BCD representation of the version of the HCI specification that is implemented by this HC. For example, a value of 0x11 corresponds to version 1.1. All of the HC implementations that are compliant with this specification will have a value of 0x10.</p>

##### 8.4.1.4.2. HcControl Register(Default Value: 0x00000000)

Offset: 0x404				Register Name: <b>HcRevision</b>
Bit	Read/Write		Default/HEX	Description
	HCD	HC		
31:11	/	/	0x00	Reserved

10	R/W	R	0x0	<p><b>RemoteWakeupEnable</b></p> <p>This bit is used by HCD to enable or disable the remote wakeup feature upon the detection of upstream resume signaling. When this bit is set and the ResumeDetected bit in HcInterruptStatus is set, a remote wakeup is signaled to the host system. Setting this bit has no impact on the generation of hardware interrupt.</p>								
9	R/W	R/W	0x0	<p><b>RemoteWakeupConnected</b></p> <p>This bit indicates whether HC supports remote wakeup signaling. If remote wakeup is supported and used by the system, it is the responsibility of system firmware to set this bit during POST. HC clear the bit upon a hardware reset but does not alter it upon a software reset. Remote wakeup signaling of the host system is host-bus-specific and is not described in this specification.</p>								
8	R/W	R	0x0	<p><b>InterruptRouting</b></p> <p>This bit determines the routing of interrupts generated by events registered in HcInterruptStatus. If clear, all interrupt are routed to the normal host bus interrupt mechanism. If set interrupts are routed to the System Management Interrupt. HCD clears this bit upon a hardware reset, but it does not alter this bit upon a software reset. HCD uses this bit as a tag to indicate the ownership of HC.</p>								
7:6	R/W	R/W	0x0	<p><b>HostControllerFunctionalState for USB</b></p> <table border="1" data-bbox="603 1064 1426 1238"> <tr> <td>00b</td> <td>USBReset</td> </tr> <tr> <td>01b</td> <td>USBResume</td> </tr> <tr> <td>10b</td> <td>USBOperational</td> </tr> <tr> <td>11b</td> <td>USBSuspend</td> </tr> </table> <p>A transition to USBOperational from another state causes SOF generation to begin 1 ms later. HCD may determine whether HC has begun sending SOFs by reading the StartoFrame field of HcInterruptStatus.</p> <p>This field may be changed by HC only when in the USBsuspend state. HC may move from the USBsuspend state to the USBRESUME state after detecting the resume signaling from a downstream port.</p> <p>HC enters USBsuspend after a software reset, whereas it enters USBRESET after a hardware reset. The latter also resets the Root Hub and asserts subsequent reset signaling to downstream ports.</p>	00b	USBReset	01b	USBResume	10b	USBOperational	11b	USBSuspend
00b	USBReset											
01b	USBResume											
10b	USBOperational											
11b	USBSuspend											
5	R/W	R	0x0	<p><b>BulkListEnable</b></p> <p>This bit is set to enable the processing of the Bulk list in the next Frame. If cleared by HCD, processing of the Bulk list does not occur after the next SOF. HC checks this bit whenever it determines to process the list. When disabled, HCD may modify the list. If HcBulkCurrentED is pointing to an ED to be removed, HCD must advance the pointer by updating HcBulkCurrentED before re-enabling processing of the list.</p>								
4	R/W	R	0x0	<p><b>ControlListEnable</b></p> <p>This bit is set to enable the processing of the Control list in the next Frame. If cleared by HCD, processing of the Control list does not occur after the</p>								

				next SOF. HC must check this bit whenever it determines to process the list. When disabled, HCD may modify the list. If HcControlCurrentED is pointing to an ED to be removed, HCD must advance the pointer by updating HcControlCurrentED before re-enabling processing of the list.										
3	R/W	R	0x0	<p><b>IsochronousEnable</b> This bit is used by HCD to enable/disable processing of isochronous EDs. While processing the periodic list in a Frame, HC checks the status of this bit when it finds an Isochronous ED (F=1). If set (enabled), HC continues processing the EDs. If cleared (disabled), HC halts processing of the periodic list (which now contains only isochronous EDs) and begins processing the Bulk/Control lists. Setting this bit is guaranteed to take effect in the next Frame (not the current Frame).</p>										
2	R/W	R	0x0	<p><b>PeriodicListEnable</b> This bit is set to enable the processing of periodic list in the next Frame. If cleared by HCD, processing of the periodic list does not occur after the next SOF. HC must check this bit before it starts processing the list.</p>										
1:0	R/W	R	0x0	<p><b>ControlBulkServiceRatio</b> This specifies the service ratio between Control and Bulk EDs. Before processing any of the nonperiodic lists, HC must compare the ratio specified with its internal count on how many nonempty Control EDs have been processed, in determining whether to continue serving another Control ED or switching to Bulk EDs. The internal count will be retained when crossing the frame boundary. In case of reset, HCD is responsible for restoring this value.</p> <table border="1" data-bbox="603 1227 1375 1458"> <thead> <tr> <th>CBSR</th> <th>No. of Control EDs Over Bulk EDs Served</th> </tr> </thead> <tbody> <tr> <td>0</td> <td>1:1</td> </tr> <tr> <td>1</td> <td>2:1</td> </tr> <tr> <td>2</td> <td>3:1</td> </tr> <tr> <td>3</td> <td>4:1</td> </tr> </tbody> </table> <p>The default value is 0x0.</p>	CBSR	No. of Control EDs Over Bulk EDs Served	0	1:1	1	2:1	2	3:1	3	4:1
CBSR	No. of Control EDs Over Bulk EDs Served													
0	1:1													
1	2:1													
2	3:1													
3	4:1													

#### 8.4.1.4.3. HcCommandStatus Register(Default Value: 0x00000000)

Offset: 0x408				Register Name: <b>HcCommandStatus</b>
Bit	Read/Write		Default/HEX	Description
	HCD	HC		
31:18	/	/	0x0	Reserved
17:16	R	R/W	0x0	<p><b>SchedulingOverrunCount</b> These bits are incremented on each scheduling overrun error. It is initialized to 00b and wraps around at 11b. This will be incremented when a scheduling overrun is detected even if SchedulingOverrun in HcInterruptStatus has already been set. This is used by HCD to monitor any</p>

				persistent scheduling problem.
15:4	/	/	0x0	Reserved
3	R/W	R/W	0x0	<p><b>OwenshipChangeRequest</b> This bit is set by an OS HCD to request a change of control of the HC. When set HC will set the OwnershipChange field in HcInterruptStatus. After the changeover, this bit is cleared and remains so until the next request from OS HCD.</p>
2	R/W	R/W	0x0	<p><b>BulkListFilled</b> This bit is used to indicate whether there are any TDs on the Bulk list. It is set by HCD whenever it adds a TD to an ED in the Bulk list. When HC begins to process the head of the Bulk list, it checks BLF. As long as BulkListFilled is 0, HC will not start processing the Bulk list. If BulkListFilled is 1, HC will start processing the Bulk list and will set BF to 0. If HC finds a TD on the list, then HC will set BulkListFilled to 1 causing the Bulk list processing to continue. If no TD is found on the Bulk list, and if HCD does not set BulkListFilled, then BulkListFilled will still be 0 when HC completes processing the Bulk list and Bulk list processing will stop.</p>
1	R/W	R/W	0x0	<p><b>ControlListFilled</b> This bit is used to indicate whether there are any TDs on the Control list. It is set by HCD whenever it adds a TD to an ED in the Control list. When HC begins to process the head of the Control list, it checks CLF. As long as ControlListFilled is 0, HC will not start processing the Control list. If CF is 1, HC will start processing the Control list and will set ControlListFilled to 0. If HC finds a TD on the list, then HC will set ControlListFilled to 1 causing the Control list processing to continue. If no TD is found on the Control list, and if the HCD does not set ControlListFilled, then ControlListFilled will still be 0 when HC completes processing the Control list and Control list processing will stop.</p>
0	R/W	R/E	0x0	<p><b>HostControllerReset</b> This bit is by HCD to initiate a software reset of HC. Regardless of the functional state of HC, it moves to the USBSuspend state in which most of the operational registers are reset except those stated otherwise; e.g, the InterruptRouting field of HcControl, and no Host bus accesses are allowed. This bit is cleared by HC upon the completion of the reset operation. The reset operation must be completed within 10 ms. This bit, when set, should not cause a reset to the Root Hub and no subsequent reset signaling should be asserted to its downstream ports.</p>

#### 8.4.1.4.4. HcInterruptStatus Register(Default Value: 0x00000000)

Offset: 0x40c			Register Name: <b>HcInterruptStatus</b>	
Bit	Read/Write		Default/HEX	Description
	HCD	HC		
31:7	/	/	0x0	Reserved



6	R/W	R/W	0x0	<b>RootHubStatusChange</b> This bit is set when the content of HcRhStatus or the content of any of HcRhPortStatus[NumberOfDownstreamPort] has changed.
5	R/W	R/W	0x0	<b>FrameNumberOverflow</b> This bit is set when the MSb of HcFmNumber (bit 15) changes value, from 0 to 1 or from 1 to 0, and after HccaFrameNumber has been updated.
4	R/W	R/W	0x0	<b>UnrecoverableError</b> This bit is set when HC detects a system error not related to USB. HC should not proceed with any processing nor signaling before the system error has been corrected. HCD clears this bit after HC has been reset.
3	R/W	R/W	0x0	<b>ResumeDetected</b> This bit is set when HC detects that a device on the USB is asserting resume signaling. It is the transition from no resume signaling to resume signaling causing this bit to be set. This bit is not set when HCD sets the USBResume state.
2	R/W	R/W	0x0	<b>StartofFrame</b> This bit is set by HC at each start of frame and after the update of HccaFrameNumber. HC also generates a SOF token at the same time.
1	R/W	R/W	0x0	<b>WritebackDoneHead</b> This bit is set immediately after HC has written HcDoneHead to HccaDoneHead. Further updates of the HccaDoneHead will not occur until this bit has been cleared. HCD should only clear this bit after it has saved the content of HccaDoneHead.
0	R/W	R/W	0x0	<b>SchedulingOverrun</b> This bit is set when the USB schedule for the current Frame overruns and after the update of HccaFrameNumber. A scheduling overrun will also cause the SchedulingOverrunCount of HcCommandStatus to be Incremented.

#### 8.4.1.4.5. HcInterruptEnable Register(Default Value: 0x00000000)

Offset: 0x410				Register Name: <b>HcInterruptEnable Register</b>	
Bit	Read/Write		Default	Description	
	HCD	HC			
31	R/W	R	0x0	<b>MasterInterruptEnable</b> A '0' written to this field is ignored by HC. A '1' written to this field enables interrupt generation due to events specified in the other bits of this register. This is used by HCD as Master Interrupt Enable.	
30:7	/	/	0x0	Reserved	
<b>RootHubStatusChange Interrupt Enable</b>					
6	R/W	R	0x0	0	Ignore;
				1	Enable interrupt generation due to Root Hub Status Change;
5	R/W	R	0x0	<b>FrameNumberOverflow Interrupt Enable</b>	

				0	Ignore;
				1	Enable interrupt generation due to Frame Number Over Flow;
4	R/W	R	0x0	UnrecoverableError Interrupt Enable	
				0	Ignore;
				1	Enable interrupt generation due to Unrecoverable Error;
3	R/W	R	0x0	ResumeDetected Interrupt Enable	
				0	Ignore;
				1	Enable interrupt generation due to Resume Detected;
2	R/W	R	0x0	StartofFrame Interrupt Enable	
				0	Ignore;
				1	Enable interrupt generation due to Start of Flame;
1	R/W	R	0x0	WritebackDoneHead Interrupt Enable	
				0	Ignore;
				1	Enable interrupt generation due to Write back Done Head;
0	R/W	R	0x0	SchedulingOverrun Interrupt Enable	
				0	Ignore;
				1	Enable interrupt generation due to Scheduling Overrun;

#### 8.4.1.4.6. HcInterruptDisable Register(Default Value: 0x00000000)

Offset: 0x414				Register Name: <b>HcInterruptDisable Register</b>	
Bit	Read/Write		Default/HEX	Description	
	HCD	HC			
31	R/W	R	0x0	MasterInterruptEnable A written '0' to this field is ignored by HC. A '1' written to this field disables interrupt generation due events specified in the other bits of this register. This field is set after a hardware or software reset.	
30:7	/	/	0x00	Reserved	
6	R/W	R	0x0	RootHubStatusChange Interrupt Disable	
				0	Ignore;
				1	Disable interrupt generation due to Root Hub Status Change;
5	R/W	R	0x0	FrameNumberOverflow Interrupt Disable	
				0	Ignore;
				1	Disable interrupt generation due to Frame Number Over Flow;
4	R/W	R	0x0	UnrecoverableError Interrupt Disable	
				0	Ignore;
				1	Disable interrupt generation due to Unrecoverable Error;
3	R/W	R	0x0	ResumeDetected Interrupt Disable	
				0	Ignore;
				1	Disable interrupt generation due to Resume Detected;
2	R/W	R	0x0	StartofFrame Interrupt Disable	

				0	Ignore;
				1	Disable interrupt generation due to Start of Flame;
				WritebackDoneHead Interrupt Disable	
				0	Ignore;
1	R/W	R	0x0	1	Disable interrupt generation due to Write back Done Head;
				SchedulingOverrun Interrupt Disable	
				0	Ignore;
0	R/w	R	0x0	1	Disable interrupt generation due to Scheduling Overrun;

**8.4.1.4.7. HcHCCA Register(Default Value: 0x00000000)**

Offset: 0x418				Register Name: <b>HcHCCA</b>	
Bit	Read/Write		Default/HEX	Description	
	HCD	HC			
31:8	R/W	R	0x0	HCCA[31:8] This is the base address of the Host Controller Communication Area. This area is used to hold the control structures and the Interrupt table that are accessed by both the Host Controller and the Host Controller Driver.	
7:0	R	R	0x0	HCCA[7:0] The alignment restriction in HcHCCA register is evaluated by examining the number of zeros in the lower order bits. The minimum alignment is 256 bytes, therefore, bits 0 through 7 must always return 0 when read.	

**8.4.1.4.8. HcPeriodCurrentED Register(Default Value: 0x00000000)**

Offset: 0x41c				Register Name: <b>HcPeriodCurrentED(PCED)</b>	
Bit	Read/Write		Default/HEX	Description	
	HCD	HC			
31:4	R	R/W	0x0	PCED[31:4] This is used by HC to point to the head of one of the Periodec list which will be processed in the current Frame. The content of this register is updated by HC after a periodic ED has been processed. HCD may read the content in determining which ED is currently being processed at the time of reading.	
3:0	R	R	0x0	PCED[3:0] Because the general TD length is 16 bytes, the memory structure for the TD must be aligned to a 16-byte boundary. So the lower bits in the PCED, through bit 0 to bit 3 must be zero in this field.	

**8.4.1.4.9. HcControlHeadED Register(Default Value: 0x00000000)**

Offset: 0x420				Register Name: <b>HcControlHeadED[CHED]</b>
Bit	Read/Write		Default/HEX	Description
	HCD	HC		
31:4	R/W	R	0x0	EHCD[31:4] The HcControlHeadED register contains the physical address of the first Endpoint Descriptor of the Control list. HC traverse the Control list starting with the HcControlHeadED pointer. The content is loaded from HCCA during the initialization of HC.
3:0	R	R	0x0	EHCD[3:0] Because the general TD length is 16 bytes, the memory structure for the TD must be aligned to a 16-byte boundary. So the lower bits in the PCED, through bit 0 to bit 3 must be zero in this field.

**8.4.1.4.10. HcControlCurrentED Register(Default Value: 0x00000000)**

Offset: 0x424				Register Name: <b>HcControlCurrentED[CCED]</b>
Bit	Read/Write		Default/Hex	Description
	HCD	HC		
31:4	R/W	R/W	0x0	CCED[31:4] The pointer is advanced to the next ED after serving the present one. HC will continue processing the list from where it left off in the last Frame. When it reaches the end of the Control list, HC checks the ControlListFilled of in HcCommandStatus. If set, it copies the content of HcControlHeadED to HcControlCurrentED and clears the bit. If not set, it does nothing. HCD is allowed to modify this register only when the ControlListEnable of HcControl is cleared. When set, HCD only reads the instantaneous value of this register. Initially, this is set to zero to indicate the end of the Control list.
3:0	R	R	0x0	CCED[3:0] Because the general TD length is 16 bytes, the memory structure for the TD must be aligned to a 16-byte boundary. So the lower bits in the PCED, through bit 0 to bit 3 must be zero in this field.

**8.4.1.4.11. HcBulkHeadED Register(Default Value: 0x00000000)**

Offset: 0x428				Register Name: <b>HcBulkHeadED[BHED]</b>
Bit	Read/Write		Default/HEX	Description
	HCD	HC		
31:4	R/W	R	0x0	BHED[31:4]

				The HcBulkHeadED register contains the physical address of the first Endpoint Descriptor of the Bulk list. HC traverses the Bulk list starting with the HcBulkHeadED pointer. The content is loaded from HCCA during the initialization of HC.
3:0	R	R	0x0	BHED[3:0] Because the general TD length is 16 bytes, the memory structure for the TD must be aligned to a 16-byte boundary. So the lower bits in the PCED, through bit 0 to bit 3 must be zero in this field.

**8.4.1.4.12. HcBulkCurrentED Register(Default Value: 0x00000000)**

Offset: 0x42c				Register Name: <b>HcBulkCurrentED [BCED]</b>
Bit	Read/Write		Default/HEX	Description
	HCD	HC		
31:4	R/W	R/W	0x0	BulkCurrentED[31:4] This is advanced to the next ED after the HC has served the present one. HC continues processing the list from where it left off in the last Frame. When it reaches the end of the Bulk list, HC checks the ControlListFilled of HcControl. If set, it copies the content of HcBulkHeadED to HcBulkCurrentED and clears the bit. If it is not set, it does nothing. HCD is only allowed to modify this register when the BulkListEnable of HcControl is cleared. When set, the HCD only reads the instantaneous value of this register. This is initially set to zero to indicate the end of the Bulk list.
3:0	R	R	0x0	BulkCurrentED [3:0] Because the general TD length is 16 bytes, the memory structure for the TD must be aligned to a 16-byte boundary. So the lower bits in the PCED, through bit 0 to bit 3 must be zero in this field.

**8.4.1.4.13. HcDoneHead Register(Default Value: 0x00000000)**

Offset: 0x430				Register Name: <b>HcDoneHead</b>
Bit	Read/Write		Default/Hex	Description
	HCD	HC		
31:4	R	R/W	0x0	HcDoneHead[31:4] When a TD is completed, HC writes the content of HcDoneHead to the NextTD field of the TD. HC then overwrites the content of HcDoneHead with the address of this TD. This is set to zero whenever HC writes the content of this register to HCCA. It also sets the WritebackDoneHead of HcInterruptStatus.
3:0	R	R	0x0	HcDoneHead[3:0] Because the general TD length is 16 bytes, the memory structure for the TD must be aligned to a 16-byte boundary. So the lower bits in the PCED, through bit 0 to bit 3 must be zero in this field.

**8.4.1.4.14. HcFmInterval Register(Default Value: 0x00002EDF)**

Offset: 0x434				Register Name: <b>HcFmInterval Register</b>
Bit	Read/Write		Default/Hex	Description
	HCD	HC		
31	R/W	R	0x0	FrameIntervalToggler HCD toggles this bit whenever it loads a new value to FrameInterval.
30:16	R/W	R	0x0	FSLargestDataPacket This field specifies a value which is loaded into the Largest Data Packet Counter at the beginning of each frame. The counter value represents the largest amount of data in bits which can be sent or received by the HC in a single transaction at any given time without causing scheduling overrun. The field value is calculated by the HCD.
15:14	/	/	0x0	Reserved
13:0	R/W	R	0x2edf	FrameInterval This specifies the interval between two consecutive SOFs in bit times. The nominal value is set to be 11,999. HCD should store the current value of this field before resetting HC. By setting the HostControllerReset field of HcCommandStatus as this will cause the HC to reset this field to its nominal value. HCD may choose to restore the stored value upon the completion of the Reset sequence.

**8.4.1.4.15. HcFmRemaining Register(Default Value: 0x00000000)**

Offset: 0x438				Register Name: <b>HcFmRemaining</b>
Bit	Read/Write		Default/Hex	Description
	HCD	HC		
31	R	R/W	0x0	FrameRemaining Toggle This bit is loaded from the FrameIntervalToggle field of HcFmInterval whenever FrameRemaining reaches 0. This bit is used by HCD for the synchronization between FrameInterval and FrameRemaining.
30:14	/	/	0x0	Reserved
13:0	R	RW	0x0	FramRemaining This counter is decremented at each bit time. When it reaches zero, it is reset by loading the FrameInterval value specified in HcFmInterval at the next bit time boundary. When entering the USBOPERATIONAL state, HC re-loads the content with the FrameInterval of HcFmInterval and uses the updated value from the next SOF.

**8.4.1.4.16. HcFmNumber Register(Default Value: 0x00000000)**

Offset: 0x43c				Register Name: <b>HcFmNumber</b>
Bit	Read/Write		Default/Hex	Description
	HCD	HC		
31:16				Reserved
15:0	R	R/W	0x0	FrameNumber This is incremented when HcFmRemaining is re-loaded. It will be rolled over to 0x0 after 0x0ffff. When entering the USBOPERATIONAL state, this will be incremented automatically. The content will be written to HCCA after HC has incremented the FrameNumber at each frame boundary and sent a SOF but before HC reads the first ED in that Frame. After writing to HCCA, HC will set the StartofFrame in HcInterruptStatus.

**8.4.1.4.17. HcPeriodicStart Register(Default Value: 0x00000000)**

Offset: 0x440				Register Name: <b>HcPeriodicStatus</b>
Bit	Read/Write		Default/Hex	Description
	HCD	HC		
31:14				Reserved
13:0	R/W	R	0x0	PeriodicStart After a hardware reset, this field is cleared. This is then set by HCD during the HC initialization. The value is calculated roughly as 10% off from HcFmInterval. A typical value will be 0x2A3F (0x3e67??). When HcFmRemaining reaches the value specified, processing of the periodic lists will have priority over Control/Bulk processing. HC will therefore start processing the Interrupt list after completing the current Control or Bulk transaction that is in progress.

**8.4.1.4.18. HcLSThreshold Register(Default Value: 0x00000628)**

Offset: 0x444				Register Name: <b>HcLSThreshold</b>
Bit	Read/Write		Default/Hex	Description
	HCD	HC		
31:12				Reserved
11:0	R/W	R	0x0628	LSThreshold This field contains a value which is compared to the FrameRemaining field prior to initiating a Low Speed transaction. The transaction is started only if FrameRemaining <sup>3</sup> this field. The value is calculated by HCD with the consideration of transmission and setup overhead.

**8.4.1.4.19. HcRhDescriptorA Register(Default Value: 0x02001201)**

Offset: 0x448				Register Name: <b>HcRhDescriptorA</b>				
Bit	Read/Write		Default/Hex	Description				
	HCD	HC						
31:24	R/W	R	0x2	<b>PowerOnToPowerGoodTime[POTPGT]</b> This byte specifies the duration HCD has to wait before accessing a powered-on port of the Root Hub. It is implementation-specific. The unit of time is 2 ms. The duration is calculated as POTPGT * 2ms.				
23:13				Reserved				
12	R/W	R	1	<b>NoOverCurrentProtection</b> This bit describes how the overcurrent status for the Root Hub ports are reported. When this bit is cleared, the OverCurrentProtectionMode field specifies global or per-port reporting. <table border="1" data-bbox="619 797 1442 931"> <tr> <td>0</td> <td>Over-current status is reported collectively for all downstream ports.</td> </tr> <tr> <td>1</td> <td>No overcurrent protection supported.</td> </tr> </table>	0	Over-current status is reported collectively for all downstream ports.	1	No overcurrent protection supported.
0	Over-current status is reported collectively for all downstream ports.							
1	No overcurrent protection supported.							
11	R/W	R	0	<b>OverCurrentProtectionMode</b> This bit describes how the overcurrent status for the Root Hub ports are reported. At reset, these fields should reflect the same mode as PowerSwitchingMode. This field is valid only if the NoOverCurrentProtection field is cleared. <table border="1" data-bbox="619 1144 1442 1272"> <tr> <td>0</td> <td>Over-current status is reported collectively for all downstream ports.</td> </tr> <tr> <td>1</td> <td>Over-current status is reported on per-port basis.</td> </tr> </table>	0	Over-current status is reported collectively for all downstream ports.	1	Over-current status is reported on per-port basis.
0	Over-current status is reported collectively for all downstream ports.							
1	Over-current status is reported on per-port basis.							
10	R	R	0x0	<b>Device Type</b> This bit specifies that the Root Hub is not a compound device. The Root Hub is not permitted to be a compound device. This field should always read/write 0.				
9	R/W	R	1	<b>PowerSwitchingMode</b> This bit is used to specify how the power switching of the Root Hub ports is controlled. It is implementation-specific. This field is only valid if the NoPowerSwitching field is cleared. <table border="1" data-bbox="619 1608 1418 1904"> <tr> <td>0</td> <td>All ports are powered at the same time.</td> </tr> <tr> <td>1</td> <td>Each port is powered individually. This mode allows port power to be controlled by either the global switch or per-port switching. If the PortPowerControlMask bit is set, the port responds only to port power commands (Set/ClearPortPower). If the port mask is cleared, then the port is controlled only by the global power switch (Set/ClearGlobalPower).</td> </tr> </table>	0	All ports are powered at the same time.	1	Each port is powered individually. This mode allows port power to be controlled by either the global switch or per-port switching. If the PortPowerControlMask bit is set, the port responds only to port power commands (Set/ClearPortPower). If the port mask is cleared, then the port is controlled only by the global power switch (Set/ClearGlobalPower).
0	All ports are powered at the same time.							
1	Each port is powered individually. This mode allows port power to be controlled by either the global switch or per-port switching. If the PortPowerControlMask bit is set, the port responds only to port power commands (Set/ClearPortPower). If the port mask is cleared, then the port is controlled only by the global power switch (Set/ClearGlobalPower).							



8	R/W	R	0	<p>NoPowerSwitcing</p> <p>These bits are used to specify whether power switching is supported or ports are always powered. It is implementation-specific. When this bit is cleared, the PowerSwitchingMode specifies global or per-port switching.</p> <table border="1"> <tr> <td>0</td> <td>Ports are power switched.</td> </tr> <tr> <td>1</td> <td>Ports are always powered on when the HC is powered on.</td> </tr> </table>	0	Ports are power switched.	1	Ports are always powered on when the HC is powered on.
0	Ports are power switched.							
1	Ports are always powered on when the HC is powered on.							
7:0	R	R	0x01	<p>NumberDownstreamPorts</p> <p>These bits specify the number of downstream ports supported by the Root Hub. It is implementation-specific. The minimum number of ports is 1. The maximum number of ports supported.</p>				

**8.4.1.4.20. HcRhDescriptorB Register(Default Value: 0x00000000)**

Offset: 0x44c				Register Name: <b>HcRhDescriptorB Register</b>	
Bit	Read/Write		Default/Hex	Description	
	HCD	HC			
31:16	R/W	R	0x0	PortPowerControlMask	
				Each bit indicates if a port is affected by a global power control command when PowerSwitchingMode is set. When set, the port's power state is only affected by per-port power control (Set/ClearPortPower). When cleared, the port is controlled by the global power switch (Set/ClearGlobalPower). If the device is configured to global switching mode (PowerSwitchingMode = 0 ), this field is not valid.	
				Bit0	Reserved
				Bit1	Ganged-power mask on Port #1.
				Bit2	Ganged-power mask on Port #2.
...					
Bit15	Ganged-power mask on Port #15.				
15:0	R/W	R	0x0	DeviceRemovable	
				Each bit is dedicated to a port of the Root Hub. When cleared, the attached device is removable. When set, the attached device is not removable.	
				Bit0	Reserved
				Bit1	Device attached to Port #1.
				Bit2	Device attached to Port #2.
...					
Bit15	Device attached to Port #15.				

8.4.1.4.21. HcRhStatus Register(Default Value: 0x00000000)

Offset: 0x450				Register Name: HcRhStatus Register				
Bit	Read/Write		Default/Hex	Description				
	HCD	HC						
31	W	R	0	(write)ClearRemoteWakeupEnable Write a '1' clears DeviceRemoteWakeupEnable. Write a '0' has no effect.				
30:18	/	/	0x0	Reserved				
17	R/W	R	0	OverCurrentIndicatorChang This bit is set by hardware when a change has occurred to the OverCurrentIndicator field of this register. The HCD clears this bit by writing a '1'.Writing a '0' has no effect.				
16	R/W	R	0x0	(read)LocalPowerStartusChange The Root Hub does not support the local power status features, thus, this bit is always read as '0'. (write)SetGlobalPower In global power mode (PowerSwitchingMode=0), This bit is written to '1' to turn on power to all ports (clear PortPowerStatus). In per-port power mode, it sets PortPowerStatus only on ports whose PortPowerControlMask bit is not set. Writing a '0' has no effect.				
15	R/W	R	0x0	(read)DeviceRemoteWakeupEnable This bit enables a ConnectStatusChange bit as a resume event, causing a USBUSPEND to USBRESUME state transition and setting the ResumeDetected interrupt. <table border="1" data-bbox="619 1223 1442 1314"> <tr> <td>0</td> <td>ConnectStatusChange is not a remote wakeup event.</td> </tr> <tr> <td>1</td> <td>ConnectStatusChange is a remote wakeup event.</td> </tr> </table> (write)SetRemoteWakeupEnable Writing a '1' sets DeviceRemoveWakeupEnable. Writing a '0' has no effect.	0	ConnectStatusChange is not a remote wakeup event.	1	ConnectStatusChange is a remote wakeup event.
0	ConnectStatusChange is not a remote wakeup event.							
1	ConnectStatusChange is a remote wakeup event.							
14:2				Reserved				
1	R	R/W	0x0	OverCurrentIndicator This bit reports overcurrent conditions when the global reporting is implemented. When set, an overcurrent condition exists. When cleared, all power operations are normal. If per-port overcurrent protection is implemented this bit is always '0'				
0	R/W	R	0x0	(Read)LocalPowerStatus When read, this bit returns the LocalPowerStatus of the Root Hub. The Root Hub does not support the local power status feature; thus, this bit is always read as '0'. (Write)ClearGlobalPower When write, this bit is operated as the ClearGlobalPower. In global power mode (PowerSwitchingMode=0), This bit is written to '1' to turn off power to all ports (clear PortPowerStatus). In per-port power mode, it				

				clears PortPowerStatus only on ports whose PortPowerControlMask bit is not set. Writing a '0' has no effect.
--	--	--	--	--

**8.4.1.4.22. HcRhPortStatus Register(Default Value: 0x00000100)**

Offset: 0x454				Register Name: <b>HcRhPortStatus</b>
Bit	Read/Write		Default/Hex	Description
	HCD	HC		
31:21	/	/	0x0	Reserved
20	R/W	R/W	0x0	PortResetStatusChange This bit is set at the end of the 10-ms port reset signal. The HCD writes a '1' to clear this bit. Writing a '0' has no effect.
				0   port reset is not complete
				1   port reset is complete
19	R/W	R/W	0x0	PortOverCurrentIndicatorChange This bit is valid only if overcurrent conditions are reported on a per-port basis. This bit is set when Root Hub changes the PortOverCurrentIndicator bit. The HCD writes a '1' to clear this bit. Writing a '0' has no effect.
				0   no change in PortOverCurrentIndicator
				1   PortOverCurrentIndicator has changed
18	R/W	R/W	0x0	PortSuspendStatusChange This bit is set when the full resume sequence has been completed. This sequence includes the 20-s resume pulse, LS EOP, and 3-ms resynchronization delay. The HCD writes a '1' to clear this bit. Writing a '0' has no effect. This bit is also cleared when ResetStatusChange is set.
				0   resume is not completed
				1   resume completed
17	R/W	R/W	0x0	PortEnableStatusChange This bit is set when hardware events cause the PortEnableStatus bit to be cleared. Changes from HCD writes do not set this bit. The HCD writes a '1' to clear this bit. Writing a '0' has no effect.
				0   no change in PortEnableStatus
				1   change in PortEnableStatus
16	R/W	R/W	0x0	ConnectStatusChange This bit is set whenever a connect or disconnect event occurs. The HCD writes a '1' to clear this bit. Writing a '0' has no effect. If CurrentConnectStatus is cleared when a SetPortReset,SetPortEnable, or SetPortSuspend write occurs, this bit is set to force the driver to re-evaluate the connection status since these writes should not occur if the port is disconnected.
				0   no change in PortEnableStatus
				1   change in PortEnableStatus

				Note: If the DeviceRemovable[NDP] bit is set, this bit is set only after a Root Hub reset to inform the system that the device is attached.				
15:10	/	/	0x0	Reserved				
				<p>(read)LowSpeedDeviceAttached</p> <p>This bit indicates the speed of the device attached to this port. When set, a Low Speed device is attached to this port. When clear, a Full Speed device is attached to this port. This field is valid only when the CurrentConnectStatus is set.</p> <table border="1"> <tr> <td>0</td> <td>full speed device attached</td> </tr> <tr> <td>1</td> <td>low speed device attached</td> </tr> </table> <p>(write)ClearPortPower</p> <p>The HCD clears the PortPowerStatus bit by writing a '1' to this bit. Writing a '0' has no effect.</p>	0	full speed device attached	1	low speed device attached
0	full speed device attached							
1	low speed device attached							
9	R/W	R/W	-					
				<p>(read)PortPowerStatus</p> <p>This bit reflects the port's power status, regardless of the type of power switching implemented. This bit is cleared if an overcurrent condition is detected. HCD sets this bit by writing SetPortPower or SetGlobalPower. HCD clears this bit by writing ClearPortPower or ClearGlobalPower. Which power control switches are enabled is determined by PowerSwitchingMode and PortPortControlMask[NumberDownstreamPort]. In global switching mode(PowerSwitchingMode=0), only Set/ClearGlobalPower controls this bit. In per-port power switching (PowerSwitchingMode=1), if the PortPowerControlMask[NDP] bit for the port is set, only Set/ClearPortPower commands are enabled. If the mask is not set, only Set/ClearGlobalPower commands are enabled. When port power is disabled, CurrentConnectStatus, PortEnableStatus, PortSuspendStatus, and PortResetStatus should be reset.</p> <table border="1"> <tr> <td>0</td> <td>port power is off</td> </tr> <tr> <td>1</td> <td>port power is on</td> </tr> </table> <p>(write)SetPortPower</p> <p>The HCD writes a '1' to set the PortPowerStatus bit. Writing a '0' has no effect.</p>	0	port power is off	1	port power is on
0	port power is off							
1	port power is on							
8	R/W	R/W	0x1	Note: This bit is always reads '1b' if power switching is not supported.				
7:5	/	/	0x0	Reserved				
				<p>(read)PortResetStatus</p> <p>When this bit is set by a write to SetPortReset, port reset signaling is asserted. When reset is completed, this bit is cleared when PortResetStatusChange is set. This bit cannot be set if CurrentConnectStatus is cleared.</p> <table border="1"> <tr> <td>0</td> <td>port reset signal is not active</td> </tr> </table>	0	port reset signal is not active		
0	port reset signal is not active							
4	R/W	R/W	0x0					

				<table border="1"> <tr> <td>1</td> <td>port reset signal is active</td> </tr> </table> <p>(write)SetPortReset The HCD sets the port reset signaling by writing a '1' to this bit. Writing a '0' has no effect. If CurrentConnectStatus is cleared, this write does not set PortResetStatus, but instead sets ConnectStatusChange. This informs the driver that it attempted to reset a disconnected port.</p>	1	port reset signal is active		
1	port reset signal is active							
3	R/W	R/W	0x0	<p>(read)PortOverCurrentIndicator This bit is only valid when the Root Hub is configured in such a way that overcurrent conditions are reported on a per-port basis. If per-port overcurrent reporting is not supported, this bit is set to 0. If cleared, all power operations are normal for this port. If set, an overcurrent condition exists on this port. This bit always reflects the overcurrent input signal.</p> <table border="1"> <tr> <td>0</td> <td>no overcurrent condition.</td> </tr> <tr> <td>1</td> <td>overcurrent condition detected.</td> </tr> </table> <p>(write)ClearSuspendStatus The HCD writes a '1' to initiate a resume. Writing a '0' has no effect. A resume is initiated only if PortSuspendStatus is set.</p>	0	no overcurrent condition.	1	overcurrent condition detected.
0	no overcurrent condition.							
1	overcurrent condition detected.							
2	R/W	R/W	0x0	<p>(read)PortSuspendStatus This bit indicates the port is suspended or in the resume sequence. It is set by a SetSuspendState write and cleared when PortSuspendStatusChange is set at the end of the resume interval. This bit cannot be set if CurrentConnectStatus is cleared. This bit is also cleared when PortResetStatusChange is set at the end of the port reset or when the HC is placed in the USBRESUME state. If an upstream resume is in progress, it should propagate to the HC.</p> <table border="1"> <tr> <td>0</td> <td>port is not suspended</td> </tr> <tr> <td>1</td> <td>port is suspended</td> </tr> </table> <p>(write)SetPortSuspend The HCD sets the PortSuspendStatus bit by writing a '1' to this bit. Writing a '0' has no effect. If CurrentConnectStatus is cleared, this write does not set PortSuspendStatus; instead it sets ConnectStatusChange. This informs the driver that it attempted to suspend a disconnected port.</p>	0	port is not suspended	1	port is suspended
0	port is not suspended							
1	port is suspended							
1	R/W	R/W	0x0	<p>(read)PortEnableStatus This bit indicates whether the port is enabled or disabled. The Root Hub may clear this bit when an overcurrent condition, disconnect event, switched-off power, or operational bus error such as babble is detected. This change also causes PortEnabledStatusChange to be set. HCD sets this bit by writing SetPortEnable and clears it by writing ClearPortEnable. This bit cannot be set when CurrentConnectStatus is cleared. This bit is also set, if not already, at the completion of a port reset when ResetStatusChange is set or port suspend when SuspendStatusChange is set.</p>				

				<table border="1"> <tr> <td>0</td> <td>port is disabled</td> </tr> <tr> <td>1</td> <td>port is enabled</td> </tr> </table> <p>(write)SetPortEnable The HCD sets PortEnableStatus by writing a '1'. Writing a '0' has no effect. If CurrentConnectStatus is cleared, this write does not set PortEnableStatus, but instead sets ConnectStatusChange. This informs the driver that it attempted to enable a disconnected Port.</p>	0	port is disabled	1	port is enabled
0	port is disabled							
1	port is enabled							
0	R/W	R/W	0x0	<p>(read)CurrentConnectStatus This bit reflects the current state of the downstream port.</p> <table border="1"> <tr> <td>0</td> <td>No device connected</td> </tr> <tr> <td>1</td> <td>Device connected</td> </tr> </table> <p>(write)ClearPortEnable The HCD writes a '1' to clear the PortEnableStatus bit. Writing '0' has no effect. The CurrentConnectStatus is not affected by any write. Note: This bit is always read '1' when the attached device is nonremovable(DviceRemoveable[NumberDownstreamPort]).</p>	0	No device connected	1	Device connected
0	No device connected							
1	Device connected							

#### 8.4.1.5. HCI Interface Control and PHY Interface Description

##### 8.4.1.5.1. HCI Interface Control Register(Default Value: 0x10000000)

Offset: 0x800			Register Name: <b>HCI_ICR</b>
Bit	R/W	Default/Hex	Description
31:29	/	/	Reserved.
28	R	1	DMA Transfer Status Enable 0: Disable 1: Enable
27:26	/	/	Reserved.
25	R/W	0	OHCI count select 1: Simulation mode, the counters will be much shorter then real time 0: Normal mode, the counters will count full time
24	R/W	0	Simulation mode 1: Set PHY in a non-driving mode so the EHCI can detect device connection, this is used only for simulation 0: No effect
23:21	/	/	/
20	R/W	0	EHCI HS force Set 1 to this field force the ehci enter the high speed mode during bus reset. This field only valid when the bit 1 is set.
19:18	/	/	/
17	R/W	0	HSIC Connect detect 1 in this field enable the hsic phy to detect device connect pulse on the bus.

16	R/W	0	HSIC Connect Interrupt Enable Enable the HSIC connect interrupt.
15:13	/	/	/
12	R/W	0	PP2VBUS 1: ULPI wrapper interface will automatically set or clear DrvVbus register in ULPI PHY according to the port power status form the root hub 0: ULPI wrapper will ignore the difference between power status of root hub and ULPI PHY
11	R/W	0	AHB Master interface INCR16 enable 1: Use INCR16 when appropriate 0: do not use INCR16,use other enabled INCRX or unspecified length burst INCR
10	R/W	0	AHB Master interface INCR8 enable 1: Use INCR8 when appropriate 0: do not use INCR8,use other enabled INCRX or unspecified length burst INCR
9	R/W	0	AHB Master interface burst type INCR4 enable 1: Use INCR4 when appropriate 0: do not use INCR4,use other enabled INCRX or unspecified length burst INCR
8	R/W	0	AHB Master interface INCRX align enable 1: start INCRx burst only on burst x-align address 0: Start burst on any double word boundary Note: This bit must enable if any bit of 11:9 is enabled
7:2	/	/	Reserved
1	R/W	0	HSIC Phy Select 0:Select the UTMI Phy for the EHCI 1:Select the HSIC Phy for the EHCI
0	R/W	0	ULPI bypass enable。 1: Enable UTMI interface, disable ULPI interface 0: Enable ULPI interface, disable UTMI interface

**8.4.1.5.2. HSIC status Register(Default Value: 0x00000000)**

Offset: 0x804			Register Name: <b>HSIC_STATUS</b>
Bit	R/W	Default/Hex	Description
31:17	/	/	/
16	R/W	0	HSIC Connect Status 1 in this field indicates a device connect pulse being detected on the bus. This field only valid when the EHCI HS force bit and the HSIC Phy Select bit is set. When the HSIC Connect Interrupt Enable is set, 1 in this bit will generate an interrupt to the system. This register is valid on HCI1.

15:0	/	/	/
------	---	---	---

**8.4.1.5.3. HSIC UTMI PHY TUNE Register(Default Value: 0x23438E4)**

Offset: 0x818			Register Name: <b>UTMI_TUNE</b>
Bit	R/W	Default/Hex	Description
31:26	/	/	/
25:23	R/W	0x04	COMPDISTUNE
22:20	R/W	0x03	SQRXTUNE
19	R/W	0x0	TXPREEMPPULSETUNE
18:16	R/W	0x04	OTGTUNE
15:12	R/W	0x03	TXFSLSTUNE
11:8	R/W	0x08	TXVREFTUNE
7:6	R/W	0x03	TXHSXVTUNE
5:4	R/W	0x02	TXRISETUNE
3:2	R/W	0x01	TXRESTUNE
1:0	R/W	0x0	TXPREEMPAMPTUNE

**8.4.1.5.4. HSIC HSIC PHY CFG(Default Value: 0x00000000)**

Offset: 0x820			Register Name: <b>HSIC_CFG</b>
Bit	R/W	Default/Hex	Description
31:24	/	/	/
23	R/W	0x0	SIDDQ
22:16	R/W	0x0	REF CLK
15	R/W	0x0	BIST EN
14	R/W	0x0	LOOP BACK
13	R/W	0x0	T OUT SEL
12	R/W	0x0	T CLK
11:8	R/W	0x0	T ADDR
7:0	R/W	0x0	T DATA

**8.4.1.5.5. HSIC HSIC PHY STATUS(Default Value: 0x00000000)**

Offset: 0x824			Register Name: <b>HSIC_STATUS</b>
Bit	R/W	Default/Hex	Description
31:6	/	/	/
5	R/W	0x0	BIST Error 0: HSIC BIST Pass 1: HSIC BIST Fail



4	R/W	0x0	Bist Done 0: HSIC BIST is in progress 1: HSIC BIST is done
3:0	R/W	0x0	T DATA OUT HSIC Test Data Out

## 8.5. EMAC

### 8.5.1. Overview

The Ethernet MAC(EMAC) controller enables a host to transmit and receive data over Ethernet in compliance with the IEEE 802.3-2002 standard. It supports 10M/100M/1000M external PHY with MII/ RGMII interface in both full and half duplex mode. The internal DMA is designed for packet-oriented data transfers based on a linked list of descriptors. 4K Byte TXFIFO and 16K Byte RXFIFO are provided to keep continuous transmission and reception. Flow Control, CRC Pad & Stripping, and address filtering are also supported in this module.

The Ethernet MAC Controller includes the following features:

- Supports 10/100/1000Mbps data transfer rates
- Supports MII/RGMII PHY interface
- Supports both full-duplex and half-duplex operation
- Programmable frame length to support Standard or Jumbo Ethernet frames with sizes up to 16 KB
- Supports a variety of flexible address filtering modes
- Separate 32-bit status returned for transmission and reception packets
- Optimization for packet-oriented DMA transfers with frame delimiters
- Linked-list (chained) descriptor chaining
- Descriptor architecture, allowing large blocks of data transfer with minimum CPU intervention; each descriptor can transfer up to 4 KB of data
- Comprehensive status reporting for normal operation and transfers with errors
- 4KB TXFIFO for transmission packets and 16KB RXFIFO for reception packets
- Programmable interrupt options for different operational conditions

### 8.5.2. Block Diagram

The EMAC Controller block diagram is shown below:

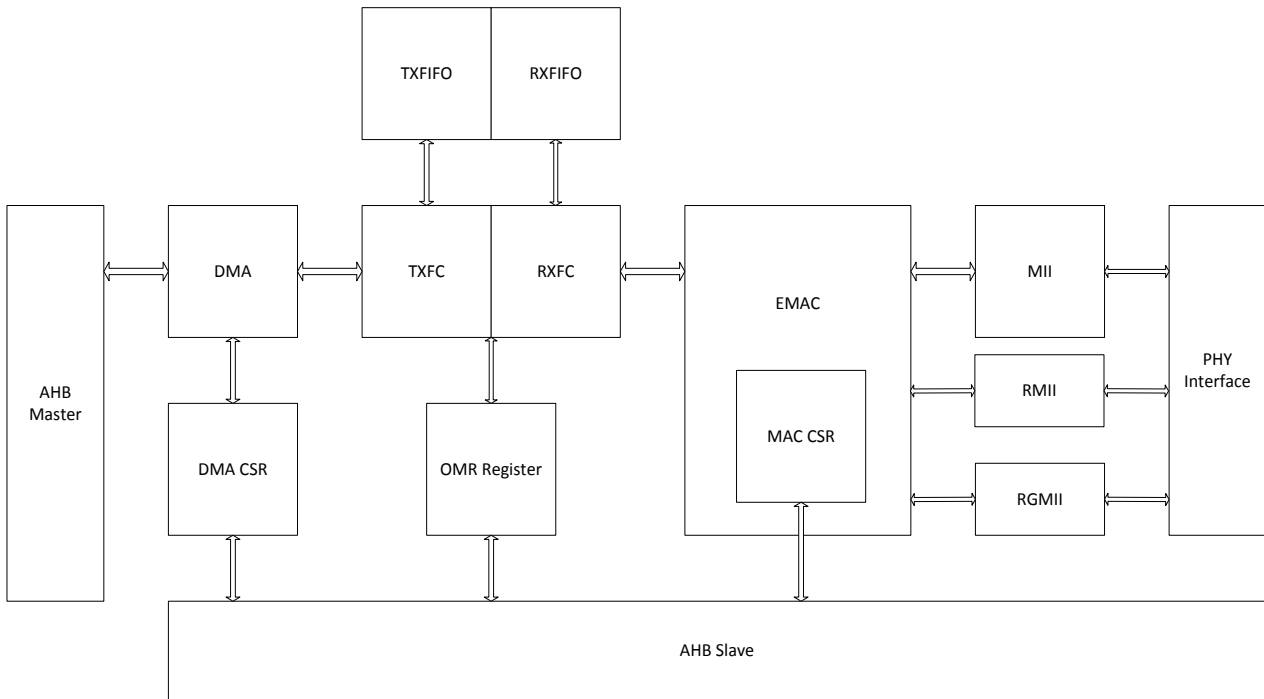

Figure7-12. EMAC Block Diagram

### 8.5.3. EMAC Core Register List

Module Name	Base Address
EMAC	0x01C30000

Register Name	Offset	Description
BASIC_CTL_0	0x00	Basic Control 0 Register
BASIC_CTL_1	0x04	Basic Control 1 Register
INT_STA	0x08	Interrupt Status Register
INT_EN	0x0C	Interrupt Enable Register
TX_CTL_0	0x10	Transmit Control 0 Register
TX_CTL_1	0x14	Transmit Control 1 Register
TX_FLOW_CTL	0x1C	Transmit Flow Control Register
TX_DMA_DESC_LIST	0x20	Transmit Descriptor List Address Register
RX_CTL_0	0x24	Receive Control 0 Register
RX_CTL_1	0x28	Receive Control 1 Register
RX_DMA_DESC_LIST	0x34	Receive Descriptor List Address Register
RX_FRM_FLT	0x38	Receive Frame Filter Register
RX_HASH_0	0x40	Hash Table 0 Register
RX_HASH_1	0x44	Hash Table 1 Register

MII_CMD	0x48	Management Interface Command Register
MII_DATA	0x4C	Management Interface Data Register
ADDR_HIGH_0	0x50	MAC Address High Register 0
ADDR_LOW_0	0x54	MAC Address High Register 0
ADDR_HIGH_x	0x50+8*x	MAC Address High Register x(x:1~7)
ADDR_LOW_x	0x54+8*x	MAC Address Low Register x(x:1~7)
TX_DMA_STA	0xB0	Transmit DMA Status Register
TX_CUR_DESC	0xB4	Current Transmit Descriptor Register
TX_CUR_BUF	0xB8	Current Transmit Buffer Address Register
RX_DMA_STA	0xC0	Receive DMA Status Register
RX_CUR_DESC	0xC4	Current Receive Descriptor Register
RX_CUR_BUF	0xC8	Current Receive Buffer Address Register
RGMII_STA	0xD0	RGMII Status Register

### 8.5.4. EMAC Core Register Description

#### 8.5.4.1. Basic Control 0 Register(Default Value: 0x00000000)

Offset: 0x00			Register Name: <b>BASIC_CTL_0</b>
Bit	R/W	Default/Hex	Description
31:4	/	/	/
3:2	R/W	0	SPEED 00: 1000Mbps 11: 100Mbps 10: 10Mbps 01: Reserved
1	R/W	0	LOOPBACK 0: Disable; 1: Enable;
0	R/W	0	DUPLEX 0: Half-duplex 1: Full-duplex

#### 8.5.4.2. Basic Control 1 Register(Default Value: 0x08000000)

Offset: 0x04			Register Name: <b>BASIC_CTL_1</b>
Bit	R/W	Default/Hex	Description
31:30	/	/	/

29:24	R/W	8	BURST_LEN The burst length of RX and TX DMA transfer.
23:2	/	/	/
1	R/W	0	RX_TX_PRI 0: RX DMA and TX DMA have same priority 1: RX DMA has priority over TX DMA
0	R/W	0	SOFT_RST When this bit is set, soft reset all registers and logic. All clock inputs must be valid before soft rest. This bit is cleared internally when the reset operation is completed fully. Before write any register, this bit should read a 0.

#### 8.5.4.3. Interrupt Status Register(Default Value: 0x00000000)

Offset: 0x08			Register Name: INT_STA
Bit	R/W	Default/Hex	Description
31:17	/	/	/
16	R	0	RGMII_LINK_STA_INT When this bit is asserted, the link status of RGMII interface is changed.
15:14	/	/	/
13	R	0	RX_EARLY_INT When this bit asserted, the RX DMA had filled the first data buffer of the receive frame.
12	R	0	RX_OVERFLOW_INT When this bit is asserted, the RX FIFO had an overflow error.
11	R	0	RX_TIMEOUT_INT When this bit asserted, the length of receive frame is greater than 2048 bytes(10240 when JUMBO_FRM_EN is set)
10	R	0	RX_DMA_STOPPED_INT When this bit asserted, the RX DMA FSM is stopped.
9	R	0	RX_BUF_UA_INT When this asserted, the RX DMA can't acquire next RX descriptor and RX DMA FSM is suspended. The ownership of next RX descriptor should be changed to RX DMA. The RX DMA FSM will resume when write to DMA_RX_START bit or next receive frame is coming.
8	R	0	RX_INT When this bit is asserted, a frame reception is completed. The RX DMA FSM remains in the running state.
7:6	/	/	/
5	R	0	TX_EARLY_INT When this bit asserted , the frame is transmitted to FIFO totally.
4	R	0	TX_UNDERFLOW_INT When this bit is asserted, the TX FIFO had an underflow error.
3	R	0	TX_TIMEOUT_INT

			When this bit is asserted, the transmitter had been excessively active.
2	R	0	TX_BUF_UA_INT When this asserted, the TX DMA can not acquire next TX descriptor and TX DMA FSM is suspended. The ownership of next TX descriptor should be changed to TX DMA. The TX DMA FSM will resume when write to DMA_TX_START bit.
1	R	0	TX_DMA_STOPPED_INT When this bit is asserted, the TX DMA FSM is stopped.
0	R	0	TX_INT When this bit is asserted, a frame transmission is completed.

#### 8.5.4.4. Interrupt Enable Register(Default Value: 0x00000000)

Offset: 0x0C			Register Name: <b>INT_EN</b>
Bit	R/W	Default/Hex	Description
31:14	/	/	/
13	R/W	0	RX_EARLY_INT_EN 0: Disable early receive interrupt enable 1: Enable early receive interrupt enable
12	R/W	0	RX_OVERFLOW_INT_EN 0: Disable overflow interrupt 1: Enable overflow interrupt
11	R/W	0	RX_TIMEOUT_INT_EN 0: Disable receive timeout interrupt 1: Enable receive timeout interrupt
10	R/W	0	RX_DMA_STOPPED_INT_EN 0: Disable receive DMA FSM stopped interrupt 1: Enable receive DMA FSM stopped interrupt
9	R/W	0	RX_BUF_UA_INT_EN 0: Disable receive buffer unavailable interrupt 1: Enable receive buffer unavailable interrupt
8	R/W	0	RX_INT_EN 0: Disable receive interrupt 1: Enable receive interrupt
7:6			
5	R/W	0	TX_EARLY_INT_EN 0: Disable early transmit interrupt 1: Enable early transmit interrupt
4	R/W	0	TX_UNDERFLOW_INT_EN 0: Disable underflow interrupt 1: Enable underflow interrupt
3	R/W	0	TX_TIMEOUT_INT_EN 0: Disable transmit timeout interrupt

			1: Enable transmit timeout interrupt
2	R/W	0	TX_BUF_UA_INT_EN 0: Disable transmit buffer available interrupt 1: Enable transmit buffer available interrupt
1	R/W	0	TX_DMA_STOPPED_INT_EN 0: Disable transmit DMA FSM stopped interrupt 1: Enable transmit DMA FSM stopped interrupt
0	R/W	0	TX_INT_EN 0: Disable transmit interrupt 1: Enable transmit interrupt

#### 8.5.4.5. Transmit Control 0 Register(Default Value: 0x00000000)

Offset: 0x10			Register Name: <b>TX_CTL_0</b>
Bit	R/W	Default/Hex	Description
31	R/W	0	TX_EN Enable transmitter. 0: Disable transmitter after current transmission 1: Enable
30	R/W	0	TX_FRM_LEN_CTL 0: Allow to transmit frames no more than 2,048 bytes (10,240 if JUMBO_FRM_EN is set) and cut off any bytes after that 1: Allow to transmit frames of up to 16,384 bytes
29:0	/	/	/

#### 8.5.4.6. Transmit Control 1 Register(Default Value: 0x00000000)

Offset: 0x14			Register Name: <b>TX_CTL_1</b>
Bit	R/W	Default/Hex	Description
31	R/W	0	TX_DMA_START When set this bit, the TX DMA FSM will go no to work. It is cleared internally and always read a 0.
30	R/W	0	TX_DMA_EN 0: Stop TX DMA after the completion of current frame transmission. 1: Start and run TX DMA.
29:11	/	/	/
10:8	R/W	0	TX_TH The threshold value of TX DMA FIFO. When TX_MD is 0, transmission starts when the size of frame in TX DMA FIFO is greater than the threshold. In addition, full frames with a length less than the threshold are transferred automatically. 000: 64

			001: 128 010: 192 011: 256 Others: Reserved
7:2	/	/	/
1	R/W	0	TX_MD 0: Transmission starts after the number of data in TX DAM FIFO is greater than TX_TH 1: Transmission starts after a full frame located in TX DMA FIFO
0	R/W	0	FLUSH_TX_FIFO The functionality that flush the data in the TX FIFO. 0: Enable 1: Disable

#### 8.5.4.7. Transmit Flow Control Register(Default Value: 0x00000000)

Offset: 0x1C			Register Name: TX_FLOW_CTL
Bit	R/W	Default/Hex	Description
31	R/W	0	TX_FLOW_CTL_STA This bit indicates a pause frame transmission is in progress. When the configuration of flow control is ready, set this bit to transmit a pause frame in full-duplex mode or activate the backpressure function. After completion of transmission, this bit will be cleared automatically. Before write register TX_FLOW_CTRL, this bit must be read as 0.
30:22	/	/	/
21:20	R/W	0	TX_PAUSE_FRM_SLOT The threshold of the pause timer at which the input flow control signal is checked for automatic retransmission of pause frame. The threshold values should be always less than the PAUSE_TIME
19:4	R/W	0	PAUSE_TIME The pause time field in the transmitted control frame.
3:2	/	/	/
1	R/W	0	ZQP_FRM_EN When set, enable the functionality to generate Zero-Quanta Pause control frame.
0	R/W	0	TX_FLOW_CTL_EN When set, enable flow control operation to transmit pause frames in full-duplex mode, or enable the back-pressure operation in half-duplex mode. 0: Disable 1: Enable



**8.5.4.8. Transmit DMA Descriptor List Address Register(Default Value: 0x00000000)**

Offset: 0x20			Register Name: <b>TX_DMA_LIST</b>
Bit	R/W	Default/Hex	Description
31:0	R/W	0	TX_DESC_LIST The base address of transmit descriptor list. It must be 32-bit aligned.

**8.5.4.9. Receive Control 0 Register(Default Value: 0x00000000)**

Offset: 0x24			Register Name: <b>RX_CTL_0</b>
Bit	R/W	Default/Hex	Description
31	R/W	0	RX_EN Enable receiver 0: Disable receiver after current reception 1: Enable
30	R/W	0	RX_FRM_LEN_CTL 0: Allow to receive frames less than or equal to 2,048 bytes (10,240 if JUMBO_FRM_EN is set) and cuts off any bytes received after that 1: Allow to receive frames of up to 16,384 bytes
29	R/W	0	JUMBO_FRM_EN When set, allows Jumbo frames of 9,018 bytes without reporting a giant frame error in the receive frame status.
28	R/W	0	STRIP_FCS When set, strip the Pad/FCS field on received frames only when the length's field value is less than or equal to 1,500 bytes.
27	R/W	0	CHECK_CRC When set, calculate CRC and check the IPv4 Header Checksum.
26:18	/	/	/
17	R/W	0	RX_PAUSE_FRM_MD 0: Only detect multicast pause frame specified in the 802.3x standard. 1: In addition to detect multicast pause frame specified in the 802.3x standard, also detect unicast pause frame with address specified in MAC Address 0 High Register and MAC address 0 Low Register.
16	R/W	0	RX_FLOW_CTL_EN When set, enable the functionality that decode the received pause frame and disable its transmitter for a specified time by pause frame.
15:0	/	/	/

**8.5.4.10. Receive Control 1 Register(Default Value: 0x00000000)**

Offset: 0x28			Register Name: <b>RX_CTL_1</b>
Bit	R/W	Default/Hex	Description

31	R/W	0	<b>RX_DMA_START</b> When set, the RX DMA will go no to work. It is cleared internally and always read a 0.
30	R/W	0	<b>RX_DMA_EN</b> 0: Stop RX DMA after finish receiving current frame 1: Start and run RX DMA
29:25	/	/	/
24	R/W	0	<b>RX_FIFO_FLOW_CTL</b> 0: Disable RX flow control 1: Enable RX flow control based on <b>RX_FLOW_CTL_TH_DEACT</b> and <b>RX_FLOW_CTL_TH_ACT</b>
23:22	R/W	0	<b>RX_FLOW_CTL_TH_DEACT</b> The threshold for deactivating flow control in both half-duplex mode and full-duplex mode 00: Full minus 1 KB 01: Full minus 2 KB 10: Full minus 3 KB 11: Full minus 4 KB
21:20	R/W	0	<b>RX_FLOW_CTL_TH_ACT</b> The threshold for activating flow control in both half-duplex mode and full-duplex mode. 00: Full minus 1 KB 01: Full minus 2 KB 10: Full minus 3 KB 11: Full minus 4 KB
19:6	/	/	/
5:4	R/W	0	<b>RX_TH</b> The threshold value of RX DMA FIFO. When <b>RX_MD</b> is 0, RX DMA starts to transfer data when the size of received frame in RX DMA FIFO is greater than the threshold. In addition, full frames with a length less than the threshold are transferred automatically. 00: 64 01: 32 10: 96 11: 128
3	R/W	0	<b>RX_ERR_FRM</b> 0: RX DMA drops frames with error 1: RX DMA forwards frames with error
2	R/W	0	<b>RX_RUNT_FRM</b> When set, forward undersized frames with no error and length less than 64bytes
1	R/W	0	<b>RX_MD</b> 0: RX DMA reads data from RX DMA FIFO to host memory after the number of data in RX DAM FIFO is greater than <b>RX_TH</b> 1: RX DMA reads data from RX DMA FIFO to host memory after a complete

			frame has been written to RX DMA FIFO
0	R/W	0	FLUSH_RX_FRM The functionality that flush the frames when receive descriptors/buffers is unavailable 0: Enable 1: Disable

**8.5.4.11. Receive DMA Descriptor List Address Register(Default Value: 0x00000000)**

Offset: 0x34			Register Name: <b>RX_DMA_LIST</b>
Bit	R/W	Default/Hex	Description
31:0	R/W	0	RX_DESC_LIST The base address of receive descriptor list. It must be 32-bit aligned.

**8.5.4.12. Receive Frame Filter Register(Default Value: 0x00000000)**

Offset: 0x38			Register Name: <b>RX_FRM_FLT</b>
Bit	R/W	Default/Hex	Description
31	R/W	0	DIS_ADDR_FILTER 0: Enable address filter 1: Disable address filter
30:18	/	/	/
17	R/W	0	DIS_BROADCAST 0: Receive all broadcast frames 1: Drop all broadcast frames
16	R/W	0	RX_ALL_MULTICAST 0: Filter multicast frame according to HASH_MULTICAST 1: Receive all multicast frames
15:14	/	/	
13:12	R/W	0	CTL_FRM_FILTER 00, 01: Drop all control frames 10: Receive all control frames 11: Receive all control frames when pass the address filter
11:10	/	/	/
9	R/W	0	HASH_MULTICAST 0: Filter multicast frames by comparing the DA field with the values in DA MAC address registers 1: Filter multicast frames according to the hash table
8	R/W	0	HASH_UNICAST 0: Filter unicast frames by comparing the DA field with the values in DA MAC address registers 1: Filter unicast frames according to the hash table

7	/	/	/
6	R/W	0	SA_FILTER_EN 0: Receive frames and update the result of SA filter 1: Update the result of SA filter. In addition, if the SA field of received frame does not match the values in SA MAC address registers, drop this frame.
5	R/W	0	SA_INV_FILTER 0: When the SA field of current frame matches the values in SA MAC address registers, it passes the SA filter 1: When the SA field of current frame does not match the values in SA MAC address registers,, it passes the SA filter
4	R/W	0	DA_INV_FILTER 0: Normal filtering of frames is performed 1: Filter both unicast and multicast frames by comparing DA field in inverse filtering mode
3:2	/	/	/
1	R/W	0	FLT_MD 0: If the HASH_MULTICAST or HASH_UNICAST is set, the frame is passed only when it matches the Hash filter 1: Receive the frame when it pass the address register filter or the hash filter(set by HASH_MULTICAST or HASH_UNICAST)
0	R/W	0	RX_ALL 0: Receive the frames that pass the SA/DA address filter 1: Receive all frames and update the result of address filter(pass or fail) in the receive status word

**8.5.4.13. Receive Hash Table 0 Register(Default Value: 0x00000000)**

Offset: 0x40			Register Name: <b>RX_HASH_0</b>
Bit	R/W	Default/Hex	Description
31:0	R/W	0	HASH_TAB_0 The upper 32 bits of Hash table for receive frame filter.

**8.5.4.14. Receive Hash Table 1 Register(Default Value: 0x00000000)**

Offset: 0x44			Register Name: <b>RX_HASH_1</b>
Bit	R/W	Default/Hex	Description
31:0	R/W	0	HASH_TAB_1 The lower 32 bits of Hash table for receive frame filter.

**8.5.4.15. MII Command Register(Default Value: 0x00000000)**

Offset: 0x48			Register Name: <b>MII_CMD</b>
Bit	R/W	Default/Hex	Description
31:23	/	/	/
22:20	R/W	0	MDC_DIV_RATIO_M MDC clock divide ration(m). The source of MDC clock is AHB clock. 000: 16 001: 32 010: 64 011: 128 Others: Reserved
19:17	/	/	/
16:12	R/W	0	PHY_ADDR Select a PHY device from 32 possible candidates.
11:9	/	/	/
8:4	R/W	0	PHY_REG_ADDR Select register in the selected PHY device
3:2	/	/	/
1	R/W	0	MII_WR 0: Read register in selected PHY and return data in EMAC_GMII_DATA 1: Write register in selected PHY using data in EMAC_GMII_DATA
0	R/W	0	MII_BUSY This bit indicates that a read or write operation is in progress. When prepared the data and register address for a write operation or the register address for a read operation, set this bit and start to access register in PHY. When this bit is cleared automatically, the read or write operation is over and the data in EMAC_GMII_DATA is valid for a read operation.

**8.5.4.16. MII Data Register(Default Value: 0x00000000)**

Offset: 0x4C			Register Name: <b>MII_DATA</b>
Bit	R/W	Default/Hex	Description
31:16	/	/	/
15:0	R/W	0	MII_DATA The 16-bit data to be written to or read from the register in the selected PHY.

**8.5.4.17. MAC Address 0 High Register(Default Value: 0x0000FFFF)**

Offset: 0x50			Register Name: <b>ADDR0_HIGH</b>
Bit	R/W	Default/Hex	Description
31:16	/	/	/

15:0	R/W	0xFFFF	MAC_ADDR_0_HIGH The upper 16bits of the 1 <sup>st</sup> MAC address.
------	-----	--------	---

**8.5.4.18. MAC Address 0 Low Register(Default Value: 0xFFFFFFFF)**

Offset: 0x54			Register Name: <b>ADDR0_LOW</b>
Bit	R/W	Default/Hex	Description
31:0	R/W	0xFFFFFFFF	MAC_ADDR_0_LOW The lower 32bits of 1 <sup>st</sup> MAC address.

**8.5.4.19. MAC Address x High Register(Default Value: 0x0000FFFF)**

Offset: 0x50+8*x (x=1~7)			Register Name: <b>ADDRx_HIGH</b>
Bit	R/W	Default/Hex	Description
31	R/W	0	MAC_ADDR_CTL 0: MAC address x(x: 1~7) is not valid, and it will be ignored by the address filter 1: MAC address x(x: 1~7) is valid
30	R/W	0.	MAC_ADDR_TYPE 1: MAC address x(x:1~7) used to compare with the source address of the received frame 0: MAC address x(x:1~7) used to compare with the destination address of the received frame
29:24	R/W	0	MAC_ADDR_BYTE_CTL MAC address byte control mask. The lower bit of mask controls the lower byte of in MAC address x(x:1~7). When the bit of mask is 1, do not compare the corresponding byte.
23:16	/	/	/
15:0	R/W	0xFFFF	MAC_ADDR_x_HIGH The upper 16bits of the MAC address x(x:1~7).

**8.5.4.20. MAC Address x Low Register(Default Value: 0xFFFFFFFF)**

Offset: 0x54+8*x (x=1~7)			Register Name: <b>ADDRx_LOW</b>
Bit	R/W	Default/Hex	Description
31:0	R/W	0xFFFFFFFF	MAC_ADDR_x_LOW The lower 32bits of MAC address x(x:1~7).

**8.5.4.21. Transmit DMA Status Register(Default Value: 0x00000000)**

Offset: 0xB0			Register Name: <b>TX_DMA_STA</b>
Bit	R/W	Default/Hex	Description
31:3	/	/	/
2:0	R	0	<b>TX_DMA_STA</b> The state of Transmit DMA FSM. 000: STOP: When reset or disable TX DMA; 001: RUN_FETCH_DESC: Fetching TX DMA descriptor; 010: RUN_WAIT_STA: Waiting for the status of TX frame; 011: RUN_TRANS_DATA: Passing frame from host memory to TX DMA FIFO; 111: RUN_CLOSE_DESC: Closing TX descriptor. 110: SUSPEND: TX descriptor unavailable or TX DMA FIFO underflow; 100, 101: Reserved;

**8.5.4.22. Transmit DMA Current Descriptor Register(Default Value: 0x00000000)**

Offset: 0xB4			Register Name: <b>TX_DMA_CUR_DESC</b>
Bit	R/W	Default/Hex	Description
31:0	R	0	The address of current transmit descriptor.

**8.5.4.23. Transmit DMA Current Buffer Address Register(Default Value: 0x00000000)**

Offset: 0xB8			Register Name: <b>TX_DMA_CUR_BUF</b>
Bit	R/W	Default/Hex	Description
31:0	R	0	The address of current transmit DMA buffer

**8.5.4.24. Receive DMA Status Register(Default Value: 0x00000000)**

Offset: 0xC0			Register Name: <b>RX_DMA_STA</b>
Bit	R/W	Default/Hex	Description
31:3	/	/	/
2:0	R	0	<b>RX_DMA_STA</b> The state of RX DMA FSM. 000: STOP: When reset or disable RX DMA; 001: RUN_FETCH_DESC: Fetching RX DMA descriptor; 011: RUN_WAIT_FRM: Waiting for frame. 100: SUSPEND: RX descriptor unavailable; 101: RUN_CLOSE_DESC: Closing RX descriptor. 111: RUN_TRANS_DATA: Passing frame from host memory to RX DMA FIFO;

			010, 110: Reserved.
--	--	--	---------------------

**8.5.4.25. Receive DMA Current Descriptor Register(Default Value: 0x00000000)**

Offset: 0xC4			Register Name: <b>RX_DMA_CUR_DESC</b>
Bit	R/W	Default/Hex	Description
31:0	R	0	The address of current receive descriptor

**8.5.4.26. Receive DMA Current Buffer Address Register(Default Value: 0x00000000)**

Offset: 0xC8			Register Name: <b>RX_DMA_CUR_BUF</b>
Bit	R/W	Default/Hex	Description
31:0	R	0	The address of current receive DMA buffer

**8.5.4.27. RGMII Status Register(Default Value: 0x00000000)**

Offset: 0xD0			Register Name: <b>RGMII_STA</b>
Bit	R/W	Default/Hex	Description
31:4	/	/	/
3	R	0	RGMII_LINK The link status of RGMII interface 0: down 1: up
2:1	R	0	RGMII_LINK_SPD The link speed of RGMII interface 00: 2.5 MHz 01: 25 MHz 10: 125 MHz
0	R	0	RGMII_LINK_MD The link Mode of RGMII interface 0: Half-Duplex 1: Full-Duplex

**8.5.5. EMAC RX/TX Descriptor**

The EMAC' internal DMA transfers data between host memory and internal RX/TX FIFO with a linked list of descriptors. Each descriptor is consisted of four words, and contains some necessary information to transfer TX and RX frames. The descriptor list structure is shown in figure 8-7. The address of each descriptor must be 32-bit aligned.



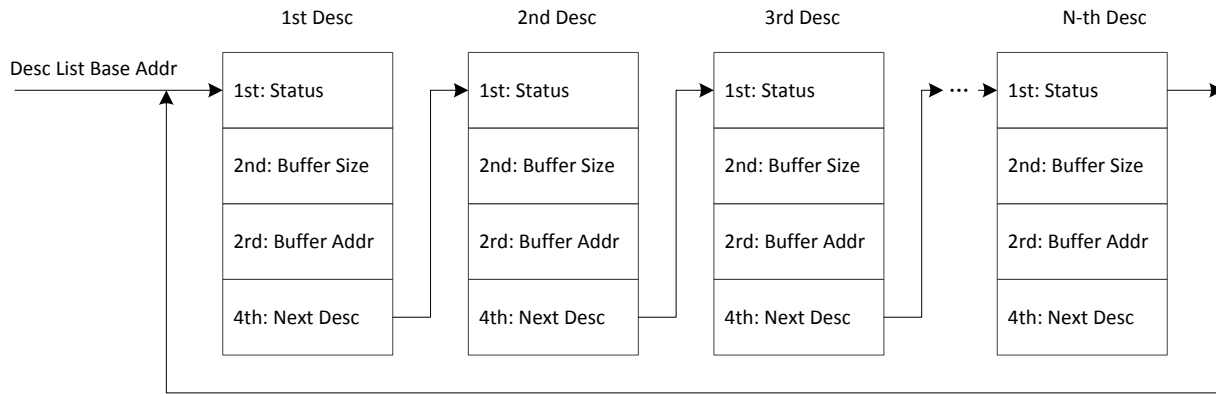

Figure 8-7. EMAC RX/TX Descriptor List

**8.5.5.1. Transmit Descriptor**

**1st Word of Transmit Descriptor**

Bits	Description
31	TX_DESC_CTL When set, current descriptor can be used by DMA. This bit is cleared by DMA when the whole frame is transmitted or all data in current descriptor’s buffer are transmitted.
30:17	Reserved
16	TX_HEADER_ERR When set, the checksum of transmitted frame’s header is wrong.
15	Reserved
14	TX LENGHT_ERR When set, the length of transmitted frame is wrong.
13	Reserved
12	TX_PAYLOAD_ERR When set, the checksum of transmitted frame’s payload is wrong.
11	Reserved
10	TX_CRS_ERR When set, carrier is lost during transmission.
9	TX_COL_ERR_0 When set, the frame is aborted because of collision after contention period.
8	TX_COL_ERR_1 When set, the frame is aborted because of too many collisions.
7	Reserved.
6:3	TX_COL_CNT The number of collisions before transmission.
2	TX_DEFER_ERR When set, the frame is aborted because of too much deferral.
1	TX_UNDERFLOW_ERR When set, the frame is aborted because of TX FIFO underflow error.

0	TX_DEFER When set in Half-Duplex mode, the EMAC defers the frame transmission.
---	---

### 2nd Word of Transmit Descriptor

Bits	Description
31	TX_INT_CTL When set and the current frame have been transmitted, the TX_INT in Interrupt Status Register will be set.
30	LAST_DESC When set, current descriptor is the last one for current frame.
29	FIR_DESC When set, current descriptor is the first one for current frame.
28:27	CHECKSUM_CTL These bits control to insert checksums in transmit frame.
26	CRC_CTL When set, CRC field is not transmitted.
25:11	Reserved
10:0	BUF_SIZE The size of buffer specified by current descriptor.

### 3rd Word of Transmit Descriptor

Bits	Description
31:0	BUF_ADDR The address of buffer specified by current descriptor.

### 4th Word of Transmit Descriptor

Bits	Description
31:0	NEXT_DESC_ADDR The address of next descriptor. It must be 32-bit aligned.

## 8.5.5.2. Receive Descriptor

### 1st Word of Receive Descriptor

Bits	Description
31	RX_DESC_CTL When set, current descriptor can be used by DMA. This bit is cleared by DMA when complete frame is received or current descriptor's buffer is full.

30	RX_DAF_FAIL When set, current frame don't pass DA filter.
29:16	RX_FRM_LEN When LAST_DESC is not set and no error bit is set, this field is the length of received data for current frame. When LAST_DESC is set, RX_OVERFLOW_ERR and RX_NO_ENOUGH_BUF_ERR are not set, this field is the length of receive frame.
15	Reserved
14	RX_NO_ENOUGH_BUF_ERR When set, current frame is clipped because of no enough buffer.
13	RX_SAF_FAIL When set, current fame don't pass SA filter.
12	Reserved.
11	RX_OVERFLOW_ERR When set, a buffer overflow error occurred and current frame is wrong.
10	Reserved
9	FIR_DESC When set, current descriptor is the first descriptor for current frame.
8	LAST_DESC When set, current descriptor is the last descriptor for current frame.
7	RX_HEADER_ERR When set, the checksum of frame's header is wrong.
6	RX_COL_ERR When set, there is a late collision during reception in half-duplex mode.
5	Reserved.
4	RX_LENGTH_ERR When set, the length of current frame is wrong.
3	RX_PHY_ERR When set, the receive error signal from PHY is asserted during reception.
2	Reserved.
1	RX_CRC_ERR When set, the CRC filed of received frame is wrong.
0	RX_PAYLOAD_ERR When set, the checksum or length of received frame's payload is wrong.

### 2nd Word of Receive Descriptor

Bits	Description
31	RX_INT_CTL When set and a frame have been received, the RX_INT will not be set.
30:11	Reserved
10:0	BUF_SIZE The size of buffer specified by current descriptor.

**3rd Word of Receive Descriptor**

Bits	Description
31:0	BUF_ADDR The address of buffer specified by current descriptor.

**4th Word of Receive Descriptor**

Bits	Description
31:0	NEXT_DESC_ADDR The address of next descriptor. This field must be 32-bit aligned.

# Chapter 9 Electrical Characteristics

## 9.1. Absolute Maximum Ratings

Absolute Maximum Ratings are those values beyond which damage to the device may occur. Table 9-1 specifies the absolute maximum ratings over the operating junction temperature range of commercial and extended temperature devices. Functional operation of the device at these or any other conditions beyond those indicated in the operational sections of this standard may damage to the device.

Table 9-1. Absolute Maximum Ratings

Symbol	Parameter	MIN	Max	Unit
$I_{I/O}$	In/Out current for input and output	-40	40	mA
AVCC	Power Supply for Analog part	-0.3	3.6	V
EPHY_VCC	Power Supply for EPHY	-0.3	3.6	V
EPHY_VDD	Power Supply for EPHY	-0.3	1.3	V
VCC-IO0/1/2/3	Power Supply for Port B, C, F,G	-0.3	3.6	V
VCC-PE0/1	Power Supply for Port E	-0.3	3.6	V
VCC-PLL	Power Supply for system PLL	-0.3	3.6	V
VCC-MCSI	Power Supply for MIPI CSI	-0.3	3.6	V
VCC-RTC	Power Supply for RTC	-0.3	3.6	V
VCC-USB	Power Supply for USB	-0.3	3.6	V
VCC-DRAM0/1/2/3/ 6/9/10	Power Supply for DDR2	-0.3	1.98	V
VDD-CPU0/1/2/3/4/ 5/6/7	Power Supply for CPU	-0.3	1.3	V
VDD-SYS0/1/2/3/4/5	Power Supply for System	-0.3	1.3	V
$T_{STG}$	Storage Temperature	-40	125	°C

## 9.2. Recommended Operating Conditions

All V3s modules are used under the operating Conditions contained in Table 9-2.

Table 9-2. Recommended Operating Conditions

Symbol	Parameter	Min	Typ	Max	Unit
Ta	Ambient Operating Temperature	-20	-	+70	°C
AVCC	Power Supply for Analog part	2.8	3.0	3.3	V
EPHY_VCC	Power Supply for EPHY	2.8	3.3	3.6	V
EPHY_VDD	Power Supply for EPHY	1.0	1.1	1.2	V
VCC-IO0/1/2/3	Power Supply for Port B,C,F,G	1.7	1.8~3.3	3.6	V
VCC-PE0/1	Power Supply for Port E	1.7	1.8~3.3	3.6	V
VCC-PLL	Power Supply for system PLL	2.7	3.0	3.3	V
VCC-MCSI	Power Supply for MIPI CSI	3.0	3.3	3.6	V
VCC-RTC	Power Supply for RTC	3.0	3.3	3.6	V
VCC-USB	Power Supply for USB	3.0	3.3	3.45	V
VCC-DRAM0/1 /2/3/6/9/10	Power Supply for DDR2	1.7	1.8	1.9	V
VDD-CPU0/1/2 /3/4/5/6/7	Power Supply for CPU	TBD	1.2	TBD	V
VDD-SYS0/1/2/ 3/4/5	Power Supply for System	TBD	1.2	TBD	V

### 9.3. DC Electrical Characteristics

Table 9-3 summarizes the DC electrical characteristics of V3s.

Table 9-3. DC Electrical Characteristics

Symbol	Parameter	Min	Typ	Max	Unit
VIH	High-Level Input Voltage	$0.7 \cdot V_{CC-I/O}$	-	$V_{CC-I/O} + 0.3$	V
VIL	Low-Level Input Voltage	-0.3	-	$0.3 \cdot V_{CC-I/O}$	V
RPU	Input pull-up resistance	50	100	150	K $\Omega$
RPD	Input pull-down resistance	50	100	150	K $\Omega$
IIH	High-Level Input Current	-	-	10	$\mu$ A
IIL	Low-Level Input Current	-	-	10	$\mu$ A
VOH	High-Level Output Voltage	$V_{CC-I/O} - 0.2$	-	$V_{CC-I/O}$	V
VOL	Low-Level Output Voltage	0	-	0.2	V
IOZ	Tri-State Output Leakage Current	-10	-	10	$\mu$ A
CIN	Input Capacitance	-	-	5	pF
COU	Output Capacitance	-	-	5	pF

## 9.4. Oscillator Electrical Characteristics

V3s contains two external input clocks:X24MIN and X32KIN, two output clocks:X24MOUT and X32KOUT.

The 24.000MHz frequency is used to generate the main source clock for PLL and the main digital blocks, the clock is provided through X24MIN.Table 9-4 lists the 24MHz crystal specifications.

Table 9-4. 24MHz Oscillator Characteristics

Symbol	Parameter	Min	Typ	Max	Unit
$1/(t_{CPMAIN})$	Crystal Oscillator Frequency Range	-	24.000	-	MHz
$t_{ST}$	Startup Time	-	-	-	ms
	Frequency Tolerance at 25 °C	-40	-	+40	ppm
	Oscillation Mode	Fundamental			-
	Maximum change over temperature range	-50	-	+50	ppm
$P_{ON}$	Drive level	-	-	50	uW
$C_L$	Equivalent Load capacitance	-	-	-	pF
CL1,CL2	Internal Load capacitance(CL1=CL2)	-	-	-	pF
$R_S$	Series Resistance(ESR)	-	-	-	$\Omega$
	Duty Cycle	30	50	70	%
$C_M$	Motional capacitance	-	-	-	pF
$C_{SHUT}$	Shunt capacitance	-	-	-	pF
$R_{BIAS}$	Internal bias resistor	-	-	-	M $\Omega$

The 32768Hz frequency is used for low frequency operation. It supplies the wake-up domain for operation in lowest power mode. The clock is provided through X32KIN.Table 9-5 lists the 32768Hz crystal specifications.

Table 9-5. 32768Hz Oscillator Characteristics

Symbol	Parameter	Min	Typ	Max	Unit
$1/(t_{CPMAIN})$	Crystal Oscillator Frequency Range	-	32768	-	Hz
$t_{ST}$	Startup Time	-	-	-	ms
	Frequency Tolerance at 25 °C	-40	-	+40	ppm
	Oscillation Mode	Fundamental			-
	Maximum change over temperature range	-50	-	+50	ppm
$P_{ON}$	Drive level	-	-	50	uW
$C_L$	Equivalent Load capacitance	-	-	-	pF
CL1,CL2	Internal Load capacitance(CL1=CL2)	-	-	-	pF
$R_S$	Series Resistance(ESR)	-	-	-	$\Omega$
	Duty Cycle	30	50	70	%
$C_M$	Motional capacitance	-	-	-	pF
$C_{SHUT}$	Shunt capacitance	-	-	-	pF
$R_{BIAS}$	Internal bias resistor	-	-	-	M $\Omega$



### 9.5. Power on and Power off Sequence

The external voltage regulator and other power-on devices must provide the processor with a specific sequence of power and resets to ensure proper operations. Following figure 9-1 and 9-2 provides the timing requirements for the V3s power.

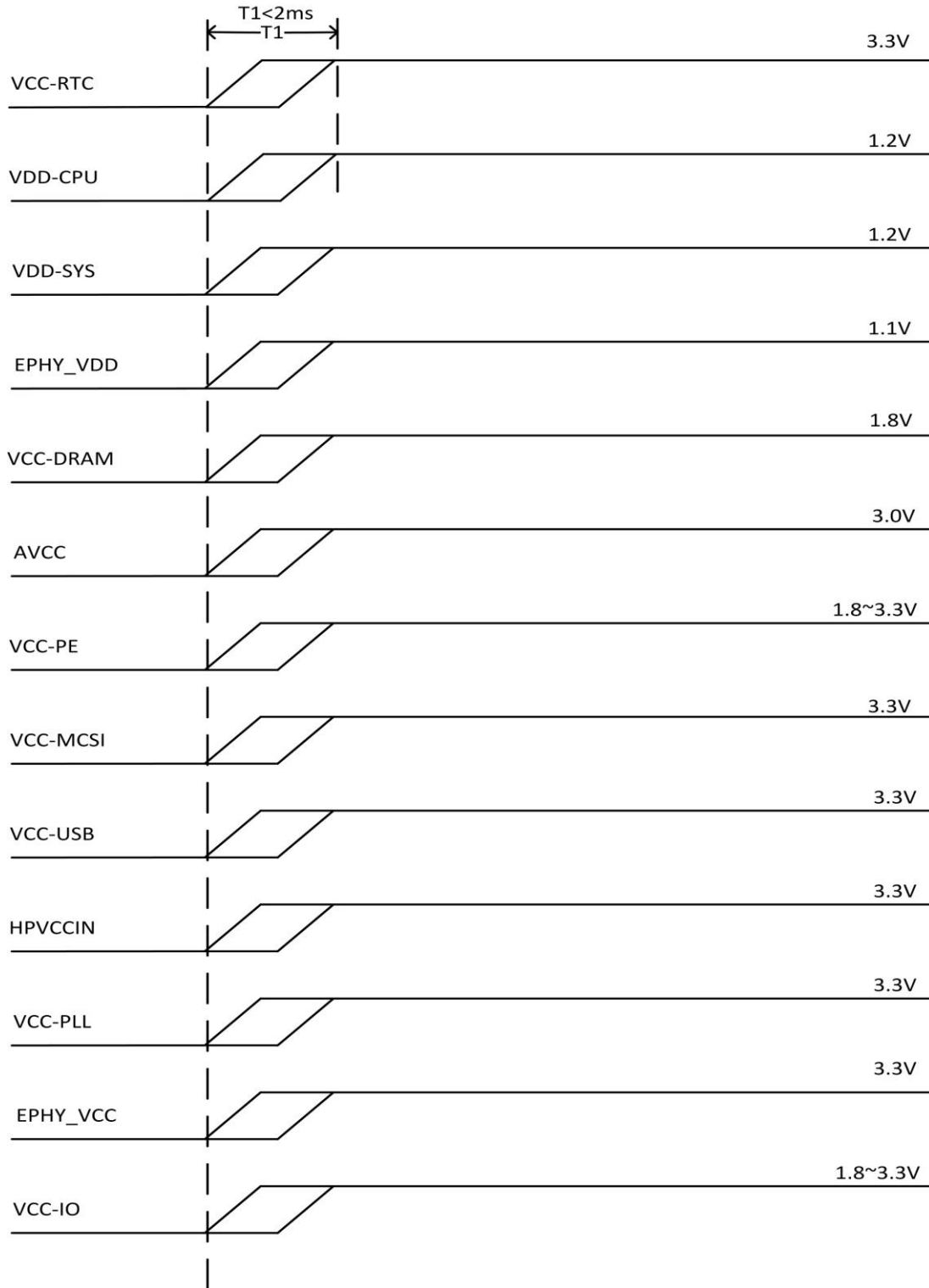

Figure 9-1. Power On Sequence

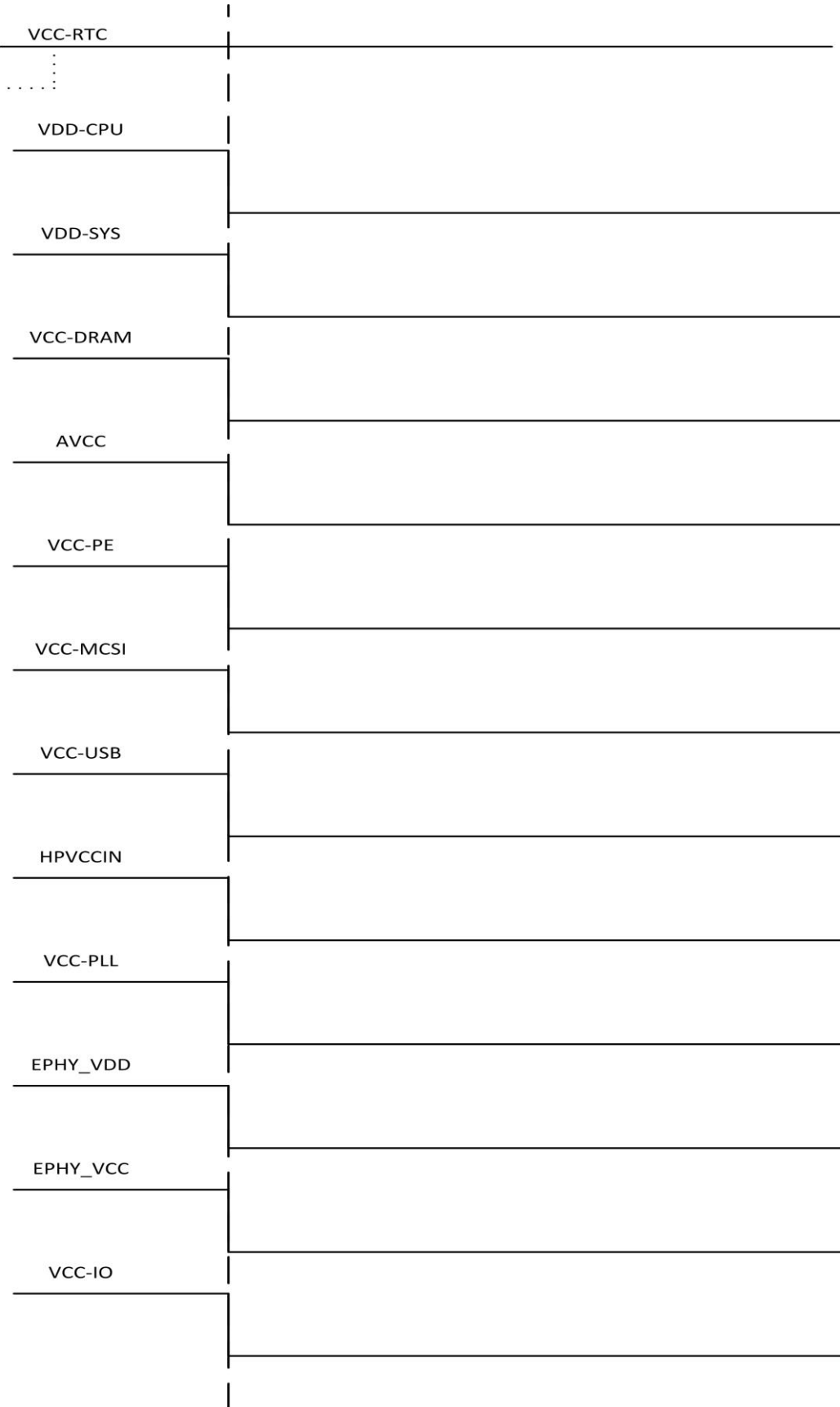
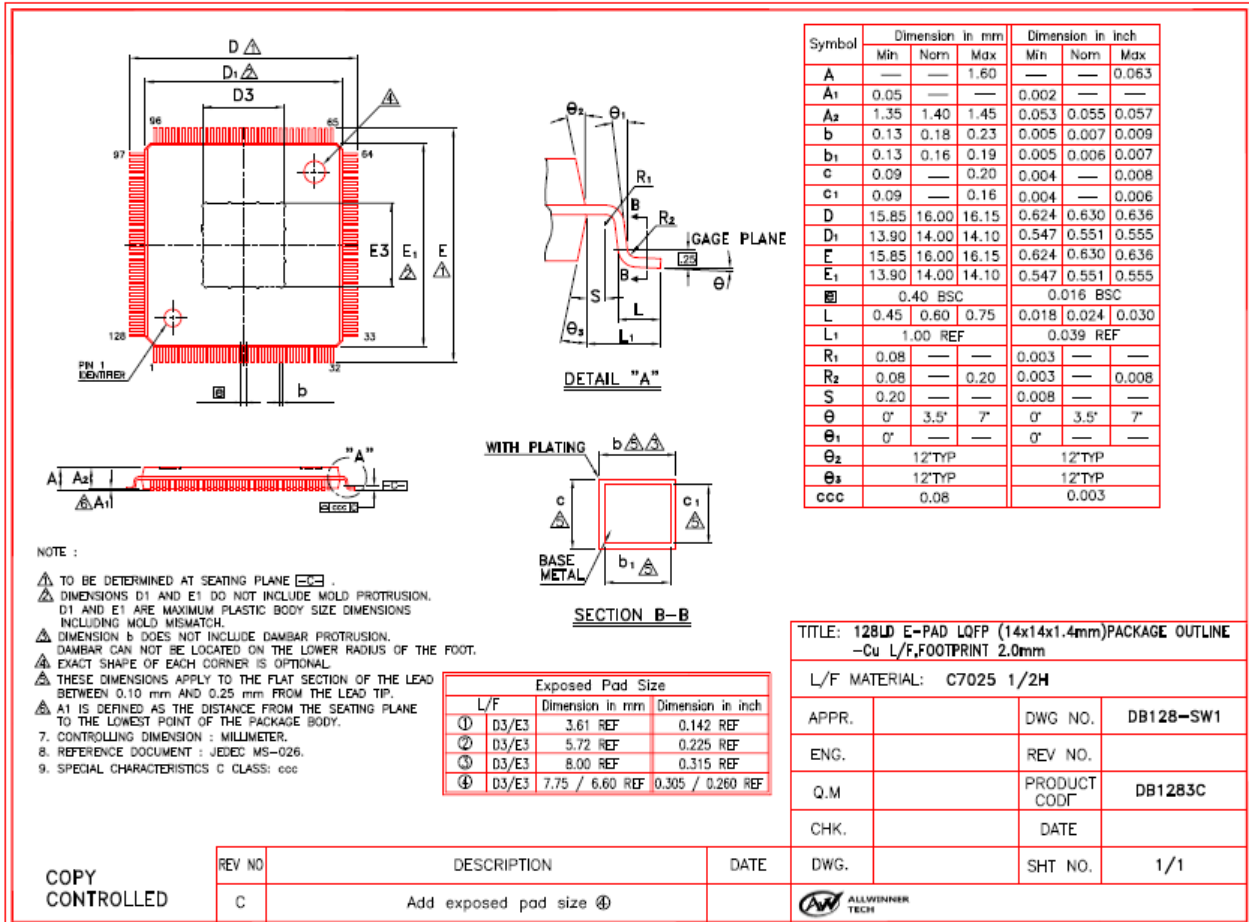

Figure 9-2. Power Down Sequence



### Package dimension

The following diagram shows the package dimension of V3s processor.



REV B

Q1-5700-10