

# DATA SHEET

## **TZA3033** **SDH/SONET STM1/OC3** **transimpedance amplifier**

Objective specification  
File under Integrated Circuits, IC19

1998 Jul 08

# SDH/SONET STM1/OC3 transimpedance amplifier

# TZA3033

### FEATURES

- Low equivalent input noise, typically 1 pA/√Hz
- Wide dynamic range, typically 0.25 μA to 1.6 mA
- Differential transimpedance of 117 kΩ
- Bandwidth minimum 150 MHz
- Differential outputs
- On-chip AGC (Automatic Gain Control)
- No external components required
- Single supply voltage from 3.0 to 5.5 V
- Bias voltage for PIN diode
- Pin compatible with SA5223.

### APPLICATIONS

- Digital fibre optic receiver in short, medium and long haul optical telecommunications transmission systems or in high speed data networks
- Wideband RF gain block.

### GENERAL DESCRIPTION

The TZA3033 is a low-noise transimpedance amplifier with AGC designed to be used in STM1/OC3 fibre optic links. It amplifies the current generated by a photo detector (PIN diode or avalanche photodiode) and converts it to a differential output voltage.

### ORDERING INFORMATION

TYPE NUMBER	PACKAGE		
	NAME	DESCRIPTION	VERSION
TZA3033T	SO8	plastic small outline package; 8 leads; body width 3.9 mm	SOT96-1
TZA3033U	naked die	die in waffle pack carriers; die dimensions 0.960 × 1.210 mm	–

### BLOCK DIAGRAM

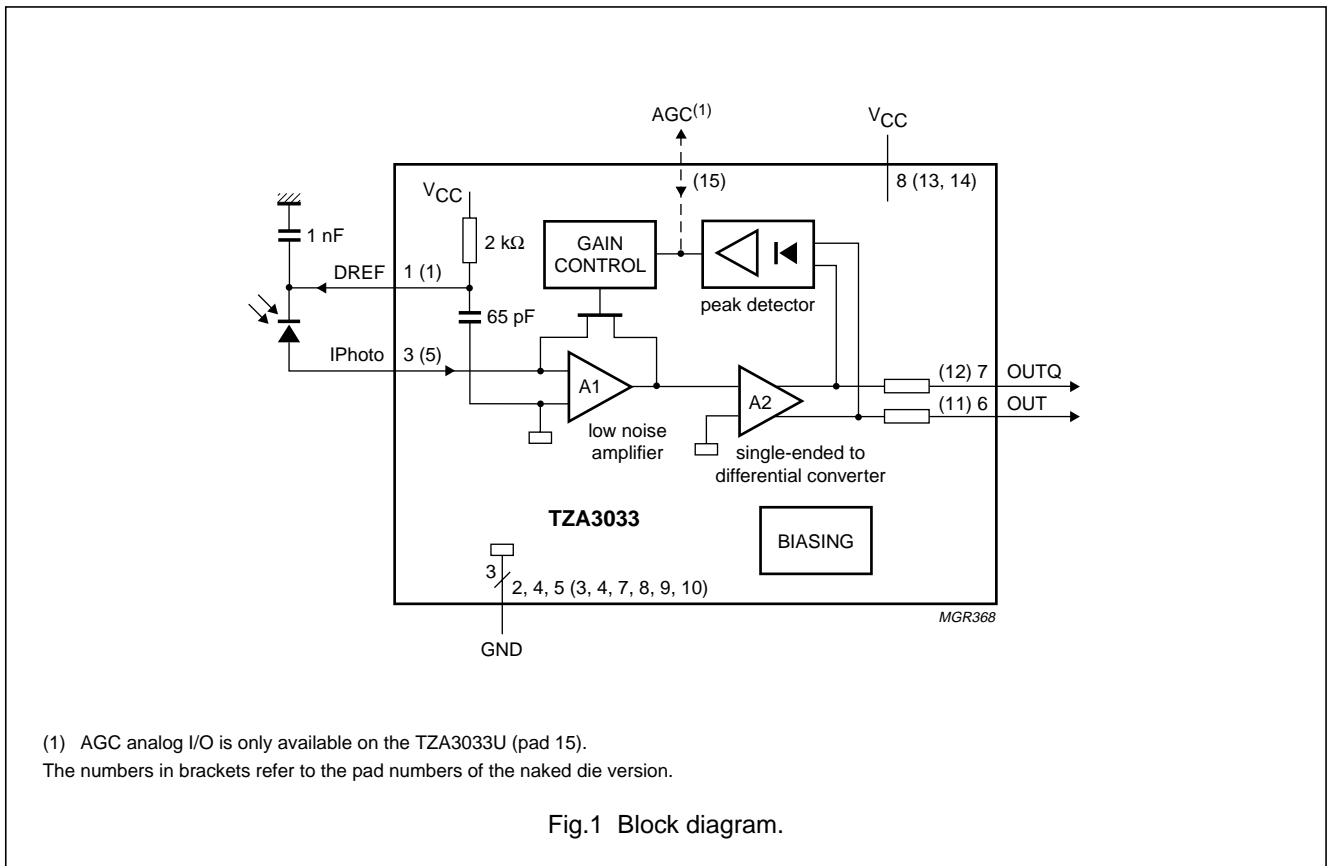

SDH/SONET STM1/OC3 transimpedance amplifier

TZA3033

**PINNING**

SYMBOL	PIN	TYPE	DESCRIPTION
DREF	1	analog output	bias voltage for PIN diode ( $V_{CC}$ ); cathode should be connected to this pin
GND	2	ground	ground
IPhoto	3	analog input	current input; anode of PIN diode should be connected to this pin; DC bias voltage is 1 048 mV
GND	4	ground	ground
GND	5	ground	ground
OUT	6	data output	data output; OUT goes HIGH when current flows into IPhoto (pin 3)
OUTQ	7	data output	compliment of OUT (pin 6)
$V_{CC}$	8	supply	supply voltage

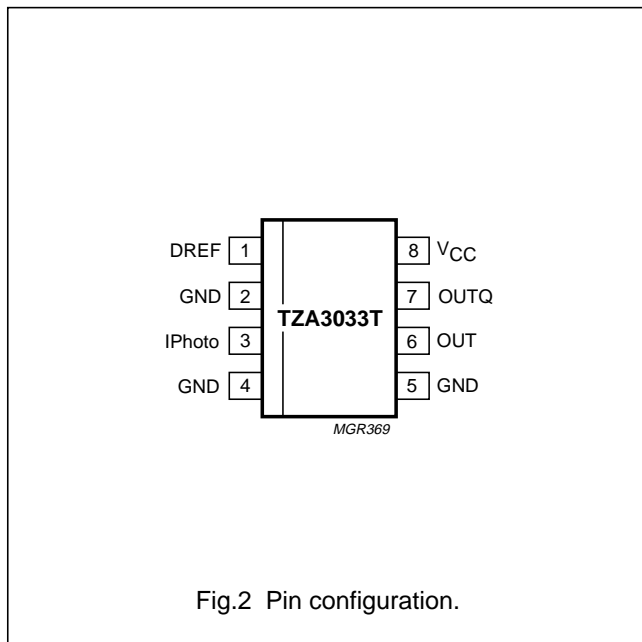

# SDH/SONET STM1/OC3 transimpedance amplifier

# TZA3033

## PAD CONFIGURATION

### Bonding pad locations

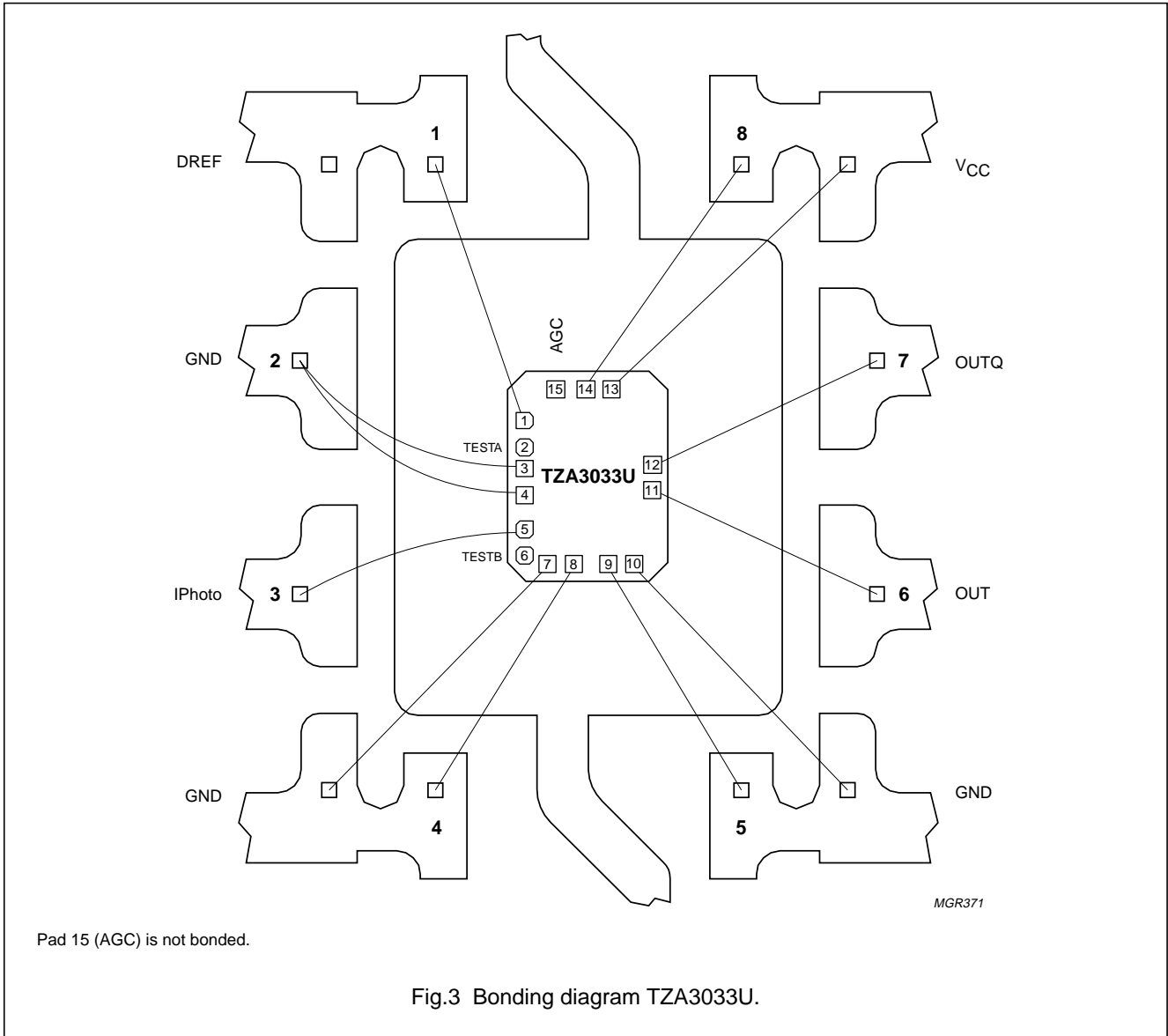

Fig.3 Bonding diagram TZA3033U.

## SDH/SONET STM1/OC3 transimpedance amplifier

## TZA3033

## Pad centre locations

SYMBOL	PAD	COORDINATES <sup>(1)</sup>	
		x	y
DREF	1	95	881
TESTA	2	95	735
GND	3	95	618
GND	4	95	473
IPhoto	5	95	285
TESTB	6	95	147
GND	7	215	95
GND	8	360	95
GND	9	549	95
GND	10	691	95
OUT	11	785	501
OUTQ	12	785	641
V <sub>CC</sub>	13	567	1055
V <sub>CC</sub>	14	424	1055
AGC	15	259	1055

## Note

- All coordinates ( $\mu\text{m}$ ) are measured with respect to the bottom left-hand corner of the die.

## FUNCTIONAL DESCRIPTION

The TZA3033 is a transimpedance amplifier intended for use in fibre optic links for signal recovery in STM1/OC3 applications. It amplifies the current generated by a photo detector (PIN diode or avalanche photodiode) and transforms it into a differential output voltage. The most important characteristics of the TZA3033 are high receiver sensitivity and wide dynamic range.

High receiver sensitivity is achieved by minimizing noise in the transimpedance amplifier.

The signal current generated by a PIN diode can vary between 0.25  $\mu\text{A}$  to 1.6 mA (peak-to-peak value). An AGC loop (see Fig.1) is implemented to make it possible to handle such a wide dynamic range. The AGC loop increases the dynamic range of the receiver by reducing the feedback resistance of the preamplifier. The AGC loop hold capacitor is integrated on-chip, so an external capacitor is not needed for AGC.

The AGC voltage can be monitored at pad 15 on the naked die (TZA3033U). Pad 15 is not bonded in the packaged device (TZA3033T). This pad can be left unconnected during normal operation. It can also be used to force an external AGC voltage. If pad 15 (AGC) is connected to V<sub>CC</sub>, the internal AGC loop is disabled and the receiver gain is at a maximum. The maximum input current is then about 10  $\mu\text{A}$ .

A differential amplifier converts the output of the preamplifier to a differential voltage. The data output circuit is given in Fig.4.

The logic level symbol definitions are shown in Fig.5.

SDH/SONET STM1/OC3 transimpedance amplifier

TZA3033

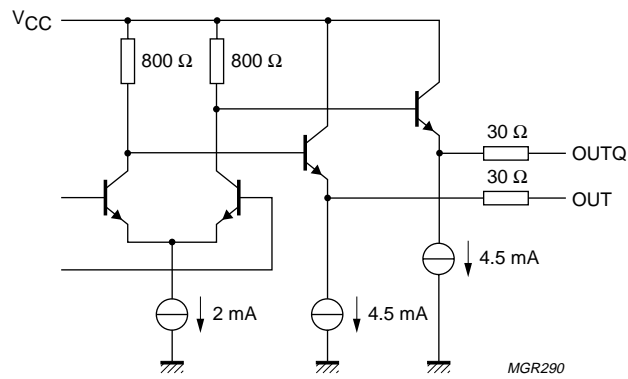

Fig.4 Data output circuit.

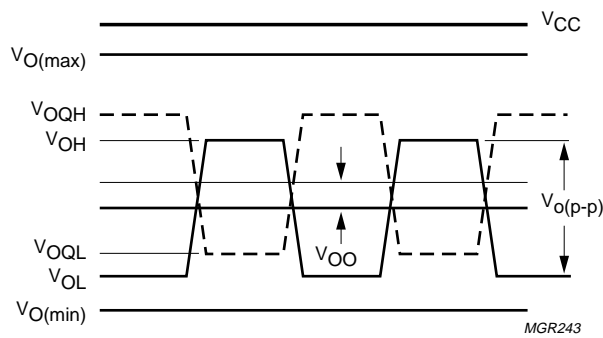

Fig.5 Logic level symbol definitions for data outputs OUT and OUTQ.

## SDH/SONET STM1/OC3 transimpedance amplifier

TZA3033

**LIMITING VALUES**

In accordance with the Absolute Maximum Rating System (IEC 134).

SYMBOL	PARAMETER	MIN.	MAX.	UNIT
$V_{CC}$	supply voltage	-0.5	+5.5	V
$V_n$	DC voltage			
	pin 3/pad 5: IPhoto	-0.5	+2	V
	pins 6 and 7/pads 11 and 12: OUT and OUTQ	-0.5	$V_{CC} + 0.5$	V
	pad 15: AGC (TZA3033U only)	-0.5	$V_{CC} + 0.5$	V
	pin 1/pad 1: DREF	-0.5	$V_{CC} + 0.5$	V
$I_n$	DC current			
	pin 3/pad 5: IPhoto	-1	+2.5	mA
	pins 6 and 7/pads 11 and 12: OUT and OUTQ	-15	+15	mA
	pad 15: AGC (TZA3033U only)	-0.2	+0.2	mA
	pin 1/pad 1: DREF	-2.5	+2.5	mA
$P_{tot}$	total power dissipation	-	300	mW
$T_{stg}$	storage temperature	-65	+150	°C
$T_j$	junction temperature	-	150	°C
$T_{amb}$	ambient temperature	-40	+85	°C

**THERMAL CHARACTERISTICS**

SYMBOL	PARAMETER	VALUE	UNIT
$R_{th(j-s)}$	thermal resistance from junction to solder point	tbF	K/W
$R_{th(j-a)}$	thermal resistance from junction to ambient	tbF	K/W

**CHARACTERISTICS**

For typical values  $T_{amb} = 25\text{ °C}$  and  $V_{CC} = 5\text{ V}$ ; minimum and maximum values are valid over the entire ambient temperature range and process spread.

SYMBOL	PARAMETER	CONDITIONS	MIN.	TYP.	MAX.	UNIT
$V_{CC}$	supply voltage		3	5	5.5	V
$I_{CC}$	supply current	AC coupled; $R_L = 50\ \Omega$	-	37	-	mA
$P_{tot}$	total power dissipation	$V_{CC} = 5\text{ V}$	-	185	-	mW
		$V_{CC} = 3.3\text{ V}$	-	116	-	mW
$T_j$	junction temperature		-40	-	+120	°C
$T_{amb}$	ambient temperature		-40	+25	+85	°C
$R_{tr}$	small-signal transresistance of the receiver	measured differentially; AC coupled				
		$R_L = \infty$	-	234	-	k $\Omega$
		$R_L = 50\ \Omega$	-	117	-	k $\Omega$
$f_{-3dB(h)}$	high frequency -3 dB point	$C_i = 0.7\text{ pF}$	120	150	-	MHz

## SDH/SONET STM1/OC3 transimpedance amplifier

TZA3033

SYMBOL	PARAMETER	CONDITIONS	MIN.	TYP.	MAX.	UNIT
$I_{n(\text{tot})}$	total integrated RMS noise current over bandwidth	referred to input; note 1				
		$\Delta f = 90 \text{ MHz}$	–	16	–	nA
		$\Delta f = 120 \text{ MHz}$	–	tbf	–	nA
		$\Delta f = 150 \text{ MHz}$	–	tbf	–	nA
$\Delta R_{\text{tr}}/\Delta t$	AGC loop constant		–	1	–	dB/ms
PSRR	power supply rejection ratio	measured differentially; note 2				
		$f = 100 \text{ kHz to } 10 \text{ MHz}$	–	0.5	–	$\mu\text{A/V}$
		$f = 100 \text{ MHz}$	–	10	–	$\mu\text{A/V}$
<b>Input: IPhoto</b>						
$I_{i(\text{IPhoto})(\text{p-p})}$	input current on pin IPhoto (peak-to-peak value)	$V_{\text{CC}} = 5 \text{ V}$	–500	+1	+1800	$\mu\text{A}$
		$V_{\text{CC}} = 3.3 \text{ V}$	–500	+1	+1600	$\mu\text{A}$
$V_{\text{bias}(\text{IPhoto})}$	input bias voltage on pin IPhoto		–	1048	–	mV
<b>Data outputs: OUT and OUTQ</b>						
$V_{\text{O}(\text{CM})}$	common mode output voltage	AC coupled; $R_{\text{L}} = 50 \Omega$	$V_{\text{CC}} - 1.800$	$V_{\text{CC}} - 1.700$	$V_{\text{CC}} - 1.600$	V
$V_{\text{O}(\text{se})(\text{p-p})}$	single-ended output voltage (peak-to-peak value)	AC coupled; $R_{\text{L}} = 50 \Omega$	–	150	260	mV
$V_{\text{OO}}$	differential output offset voltage		–100	–	+100	mV
$R_{\text{O}}$	output resistance	single-ended; DC tested	42	50	58	$\Omega$
$t_{\text{r}}$	rise time	20% to 80%	–	tbf	–	ps
$t_{\text{f}}$	fall time	80% to 20%	–	tbf	–	ps

**Notes**

- All  $I_{n(\text{tot})}$  measurements were made with an input capacitance of  $C_i = 1 \text{ pF}$ . This was comprised of 0.5 pF for the photodiode itself, with 0.3 pF allowed for the printed-circuit board layout and 0.2 pF intrinsic to the package.
- PSRR is defined as the ratio of the equivalent current change at the input ( $\Delta I_{\text{Photo}}$ ) to a change in supply voltage:

$$\text{PSRR} = \frac{\Delta I_{\text{Photo}}}{\Delta V_{\text{CC}}}$$

For example, a disturbance of +4 mV disturbance on  $V_{\text{CC}}$  at 10 MHz will typically add an extra 2 nA to the photodiode current. The external capacitor between DREF and GND has a large impact on PSRR. The specification is valid with an external capacitor of 1 nF.



# SDH/SONET STM1/OC3 transimpedance amplifier

# TZA3033

## APPLICATION INFORMATION

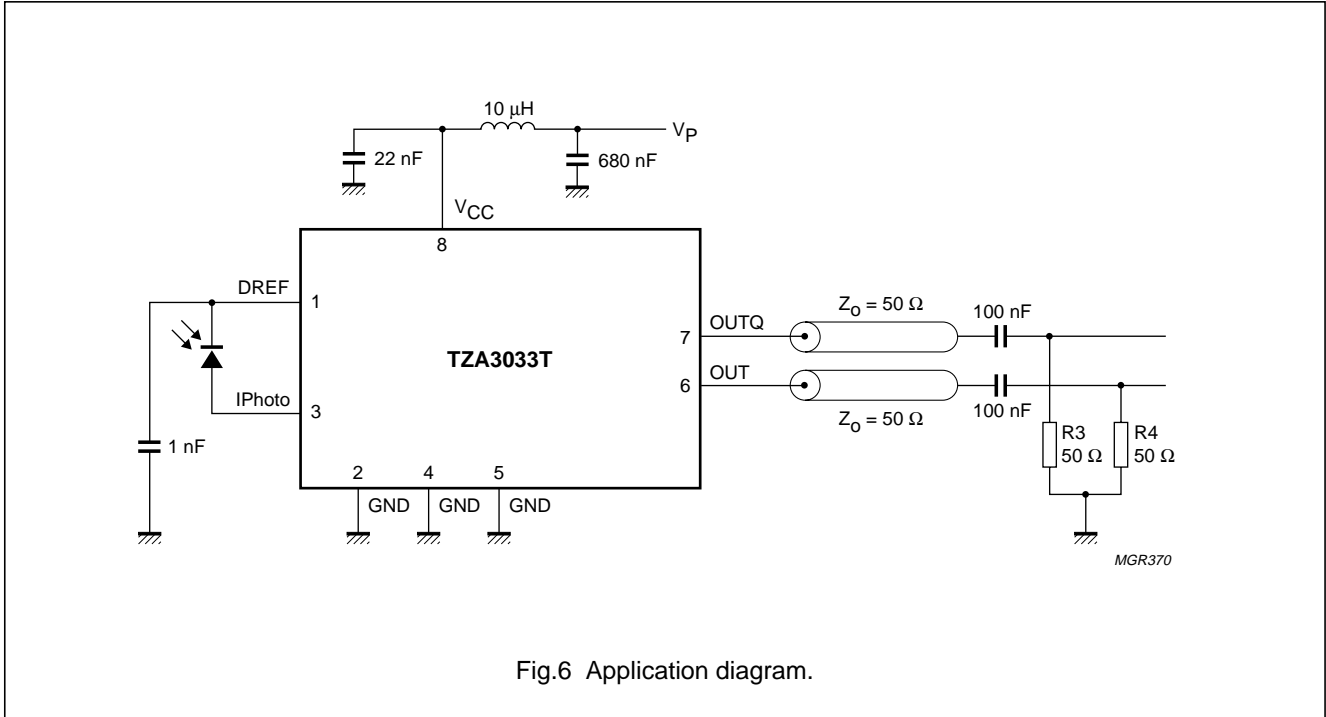

SDH/SONET STM1/OC3 transimpedance amplifier

TZA3033

PACKAGE OUTLINE

S08: plastic small outline package; 8 leads; body width 3.9 mm

SOT96-1

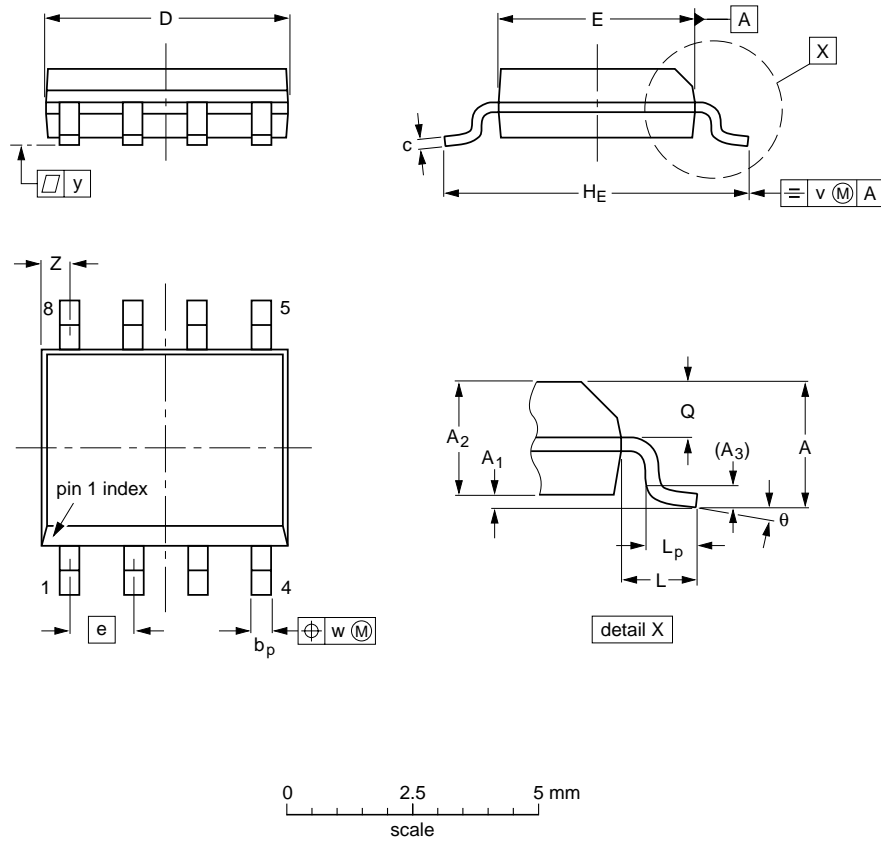

DIMENSIONS (inch dimensions are derived from the original mm dimensions)

UNIT	A max.	A <sub>1</sub>	A <sub>2</sub>	A <sub>3</sub>	b <sub>p</sub>	c	D <sup>(1)</sup>	E <sup>(2)</sup>	e	H <sub>E</sub>	L	L <sub>p</sub>	Q	v	w	y	z <sup>(1)</sup>	θ
mm	1.75	0.25 0.10	1.45 1.25	0.25	0.49 0.36	0.25 0.19	5.0 4.8	4.0 3.8	1.27	6.2 5.8	1.05	1.0 0.4	0.7 0.6	0.25	0.25	0.1	0.7 0.3	8° 0°
inches	0.069	0.010 0.004	0.057 0.049	0.01	0.019 0.014	0.0100 0.0075	0.20 0.19	0.16 0.15	0.050	0.244 0.228	0.041	0.039 0.016	0.028 0.024	0.01	0.01	0.004	0.028 0.012	

Notes

1. Plastic or metal protrusions of 0.15 mm maximum per side are not included.
2. Plastic or metal protrusions of 0.25 mm maximum per side are not included.

OUTLINE VERSION	REFERENCES				EUROPEAN PROJECTION	ISSUE DATE
	IEC	JEDEC	EIAJ			
SOT96-1	076E03S	MS-012AA				95-02-04 97-05-22

---

**SDH/SONET STM1/OC3 transimpedance amplifier****TZA3033**

---

**SOLDERING****Introduction**

There is no soldering method that is ideal for all IC packages. Wave soldering is often preferred when through-hole and surface mounted components are mixed on one printed-circuit board. However, wave soldering is not always suitable for surface mounted ICs, or for printed-circuits with high population densities. In these situations reflow soldering is often used.

This text gives a very brief insight to a complex technology. A more in-depth account of soldering ICs can be found in our *"Data Handbook IC26; Integrated Circuit Packages"* (order code 9398 652 90011).

**Reflow soldering**

Reflow soldering techniques are suitable for all SO packages.

Reflow soldering requires solder paste (a suspension of fine solder particles, flux and binding agent) to be applied to the printed-circuit board by screen printing, stencilling or pressure-syringe dispensing before package placement.

Several techniques exist for reflowing; for example, thermal conduction by heated belt. Dwell times vary between 50 and 300 seconds depending on heating method. Typical reflow temperatures range from 215 to 250 °C.

Preheating is necessary to dry the paste and evaporate the binding agent. Preheating duration: 45 minutes at 45 °C.

**Wave soldering**

Wave soldering techniques can be used for all SO packages if the following conditions are observed:

- A double-wave (a turbulent wave with high upward pressure followed by a smooth laminar wave) soldering technique should be used.
- The longitudinal axis of the package footprint must be parallel to the solder flow.
- The package footprint must incorporate solder thieves at the downstream end.

During placement and before soldering, the package must be fixed with a droplet of adhesive. The adhesive can be applied by screen printing, pin transfer or syringe dispensing. The package can be soldered after the adhesive is cured.

Maximum permissible solder temperature is 260 °C, and maximum duration of package immersion in solder is 10 seconds, if cooled to less than 150 °C within 6 seconds. Typical dwell time is 4 seconds at 250 °C.

A mildly-activated flux will eliminate the need for removal of corrosive residues in most applications.

**Repairing soldered joints**

Fix the component by first soldering two diagonally-opposite end leads. Use only a low voltage soldering iron (less than 24 V) applied to the flat part of the lead. Contact time must be limited to 10 seconds at up to 300 °C. When using a dedicated tool, all other leads can be soldered in one operation within 2 to 5 seconds between 270 and 320 °C.

## SDH/SONET STM1/OC3 transimpedance amplifier

TZA3033

**DEFINITIONS**

<b>Data sheet status</b>	
Objective specification	This data sheet contains target or goal specifications for product development.
Preliminary specification	This data sheet contains preliminary data; supplementary data may be published later.
Product specification	This data sheet contains final product specifications.
<b>Limiting values</b>	
Limiting values given are in accordance with the Absolute Maximum Rating System (IEC 134). Stress above one or more of the limiting values may cause permanent damage to the device. These are stress ratings only and operation of the device at these or at any other conditions above those given in the Characteristics sections of the specification is not implied. Exposure to limiting values for extended periods may affect device reliability.	
<b>Application information</b>	
Where application information is given, it is advisory and does not form part of the specification.	

**LIFE SUPPORT APPLICATIONS**

These products are not designed for use in life support appliances, devices, or systems where malfunction of these products can reasonably be expected to result in personal injury. Philips customers using or selling these products for use in such applications do so at their own risk and agree to fully indemnify Philips for any damages resulting from such improper use or sale.

SDH/SONET STM1/OC3 transimpedance amplifier

TZA3033

---

**NOTES**

SDH/SONET STM1/OC3 transimpedance amplifier

TZA3033

---

**NOTES**

SDH/SONET STM1/OC3 transimpedance amplifier

TZA3033

---

**NOTES**

# Philips Semiconductors – a worldwide company

**Argentina:** see South America

**Australia:** 34 Waterloo Road, NORTH RYDE, NSW 2113, Tel. +61 2 9805 4455, Fax. +61 2 9805 4466

**Austria:** Computerstr. 6, A-1101 WIEN, P.O. Box 213, Tel. +43 160 1010, Fax. +43 160 101 1210

**Belarus:** Hotel Minsk Business Center, Bld. 3, r. 1211, Volodarski Str. 6, 220050 MINSK, Tel. +375 172 200 733, Fax. +375 172 200 773

**Belgium:** see The Netherlands

**Brazil:** see South America

**Bulgaria:** Philips Bulgaria Ltd., Energoproject, 15th floor, 51 James Bourchier Blvd., 1407 SOFIA, Tel. +359 2 689 211, Fax. +359 2 689 102

**Canada:** PHILIPS SEMICONDUCTORS/COMPONENTS, Tel. +1 800 234 7381

**China/Hong Kong:** 501 Hong Kong Industrial Technology Centre, 72 Tat Chee Avenue, Kowloon Tong, HONG KONG, Tel. +852 2319 7888, Fax. +852 2319 7700

**Colombia:** see South America

**Czech Republic:** see Austria

**Denmark:** Prags Boulevard 80, PB 1919, DK-2300 COPENHAGEN S, Tel. +45 32 88 2636, Fax. +45 31 57 0044

**Finland:** Sinikalliontie 3, FIN-02630 ESPOO, Tel. +358 9 615800, Fax. +358 9 61580920

**France:** 51 Rue Carnot, BP317, 92156 SURESNES Cedex, Tel. +33 1 40 99 6161, Fax. +33 1 40 99 6427

**Germany:** Hammerbrookstraße 69, D-20097 HAMBURG, Tel. +49 40 23 53 60, Fax. +49 40 23 536 300

**Greece:** No. 15, 25th March Street, GR 17778 TAVROS/ATHENS, Tel. +30 1 4894 339/239, Fax. +30 1 4814 240

**Hungary:** see Austria

**India:** Philips INDIA Ltd, Band Box Building, 2nd floor, 254-D, Dr. Annie Besant Road, Worli, MUMBAI 400 025, Tel. +91 22 493 8541, Fax. +91 22 493 0966

**Indonesia:** PT Philips Development Corporation, Semiconductors Division, Gedung Philips, Jl. Buncit Raya Kav.99-100, JAKARTA 12510, Tel. +62 21 794 0040 ext. 2501, Fax. +62 21 794 0080

**Ireland:** Newstead, Clonskeagh, DUBLIN 14, Tel. +353 1 7640 000, Fax. +353 1 7640 200

**Israel:** RAPAC Electronics, 7 Kehilat Saloniki St, PO Box 18053, TEL AVIV 61180, Tel. +972 3 645 0444, Fax. +972 3 649 1007

**Italy:** PHILIPS SEMICONDUCTORS, Piazza IV Novembre 3, 20124 MILANO, Tel. +39 2 6752 2531, Fax. +39 2 6752 2557

**Japan:** Philips Bldg 13-37, Kohnan 2-chome, Minato-ku, TOKYO 108-8507, Tel. +81 3 3740 5130, Fax. +81 3 3740 5077

**Korea:** Philips House, 260-199 Itaewon-dong, Yongsan-ku, SEOUL, Tel. +82 2 709 1412, Fax. +82 2 709 1415

**Malaysia:** No. 76 Jalan Universiti, 46200 PETALING JAYA, SELANGOR, Tel. +60 3 750 5214, Fax. +60 3 757 4880

**Mexico:** 5900 Gateway East, Suite 200, EL PASO, TEXAS 79905, Tel. +9-5 800 234 7381

**Middle East:** see Italy

**Netherlands:** Postbus 90050, 5600 PB EINDHOVEN, Bldg. VB, Tel. +31 40 27 82785, Fax. +31 40 27 88399

**New Zealand:** 2 Wagener Place, C.P.O. Box 1041, AUCKLAND, Tel. +64 9 849 4160, Fax. +64 9 849 7811

**Norway:** Box 1, Manglerud 0612, OSLO, Tel. +47 22 74 8000, Fax. +47 22 74 8341

**Pakistan:** see Singapore

**Philippines:** Philips Semiconductors Philippines Inc., 106 Valero St. Salcedo Village, P.O. Box 2108 MCC, MAKATI, Metro MANILA, Tel. +63 2 816 6380, Fax. +63 2 817 3474

**Poland:** Ul. Lukiska 10, PL 04-123 WARSZAWA, Tel. +48 22 612 2831, Fax. +48 22 612 2327

**Portugal:** see Spain

**Romania:** see Italy

**Russia:** Philips Russia, Ul. Usatcheva 35A, 119048 MOSCOW, Tel. +7 095 755 6918, Fax. +7 095 755 6919

**Singapore:** Lorong 1, Toa Payoh, SINGAPORE 319762, Tel. +65 350 2538, Fax. +65 251 6500

**Slovakia:** see Austria

**Slovenia:** see Italy

**South Africa:** S.A. PHILIPS Pty Ltd., 195-215 Main Road Martindale, 2092 JOHANNESBURG, P.O. Box 7430 Johannesburg 2000, Tel. +27 11 470 5911, Fax. +27 11 470 5494

**South America:** Al. Vicente Pinzon, 173, 6th floor, 04547-130 SÃO PAULO, SP, Brazil, Tel. +55 11 821 2333, Fax. +55 11 821 2382

**Spain:** Balmes 22, 08007 BARCELONA, Tel. +34 93 301 6312, Fax. +34 93 301 4107

**Sweden:** Kottbygatan 7, Akalla, S-16485 STOCKHOLM, Tel. +46 8 5985 2000, Fax. +46 8 5985 2745

**Switzerland:** Allmendstrasse 140, CH-8027 ZÜRICH, Tel. +41 1 488 2741 Fax. +41 1 488 3263

**Taiwan:** Philips Semiconductors, 6F, No. 96, Chien Kuo N. Rd., Sec. 1, TAIPEI, Taiwan Tel. +886 2 2134 2865, Fax. +886 2 2134 2874

**Thailand:** PHILIPS ELECTRONICS (THAILAND) Ltd., 209/2 Sanpavuth-Bangna Road Prakanong, BANGKOK 10260, Tel. +66 2 745 4090, Fax. +66 2 398 0793

**Turkey:** Talatpasa Cad. No. 5, 80640 GÜLTEPE/ISTANBUL, Tel. +90 212 279 2770, Fax. +90 212 282 6707

**Ukraine:** PHILIPS UKRAINE, 4 Patrice Lumumba str., Building B, Floor 7, 252042 KIEV, Tel. +380 44 264 2776, Fax. +380 44 268 0461

**United Kingdom:** Philips Semiconductors Ltd., 276 Bath Road, Hayes, MIDDLESEX UB3 5BX, Tel. +44 181 730 5000, Fax. +44 181 754 8421

**United States:** 811 East Arques Avenue, SUNNYVALE, CA 94088-3409, Tel. +1 800 234 7381

**Uruguay:** see South America

**Vietnam:** see Singapore

**Yugoslavia:** PHILIPS, Trg N. Pasica 5/v, 11000 BEOGRAD, Tel. +381 11 625 344, Fax. +381 11 635 777

**For all other countries apply to:** Philips Semiconductors, International Marketing & Sales Communications, Building BE-p, P.O. Box 218, 5600 MD EINDHOVEN, The Netherlands, Fax. +31 40 27 24825

**Internet:** <http://www.semiconductors.philips.com>

© Philips Electronics N.V. 1998

SCA60

All rights are reserved. Reproduction in whole or in part is prohibited without the prior written consent of the copyright owner.

The information presented in this document does not form part of any quotation or contract, is believed to be accurate and reliable and may be changed without notice. No liability will be accepted by the publisher for any consequence of its use. Publication thereof does not convey nor imply any license under patent- or other industrial or intellectual property rights.

Printed in The Netherlands

425102/1200/01/pp16

Date of release: 1998 Jul 08

Document order number: 9397 750 03878

*Let's make things better.*

**Philips  
Semiconductors**



**PHILIPS**