

# ***Libero IDE v9.1***

*User's Guide*

---

## **Actel Corporation, Mountain View, CA 94043**

© 2010 Actel Corporation. All rights reserved.

Printed in the United States of America

Part Number: 5-02-9124-26

Release: November 2010

No part of this document may be copied or reproduced in any form or by any means without prior written consent of Actel.

Actel makes no warranties with respect to this documentation and disclaims any implied warranties of merchantability or fitness for a particular purpose. Information in this document is subject to change without notice. Actel assumes no responsibility for any errors that may appear in this document.

This document contains confidential proprietary information that is not to be disclosed to any unauthorized person without prior written consent of Actel Corporation.

### **Trademarks**

Actel and the Actel logotype are registered trademarks of Actel Corporation.

Adobe and Acrobat Reader are registered trademarks of Adobe Systems, Inc.

Mentor Graphics, Precision RTL, Exemplar Spectrum, and LeonardoSpectrum are registered trademarks of Mentor Graphics, Inc.

WaveFormer Lite is a registered trademark of SynaptiCAD, Inc.

Synplify is a registered trademark of Synplicity, Inc.

Sun and Sun Workstation, SunOS, and Solaris are trademarks or registered trademarks of Sun Microsystems, Inc

Synopsys is a registered trademark of Synopsys, Inc.

Verilog is a registered trademark of Open Verilog International.

Viewlogic, ViewSim, ViewDraw and SpeedWave are trademarks or registered trademarks of Viewlogic Systems, Inc.

Windows is a registered trademark and Windows NT is a trademark of Microsoft Corporation in the U.S. and other countries.

UNIX is a registered trademark of X/Open Company Limited.

All other products or brand names mentioned are trademarks or registered trademarks of their respective holders.

# Table of Contents

<b>What's New in Libero IDE v9.1 .....</b>	<b>7</b>
<b>Supported Families .....</b>	<b>8</b>
<b>Project Management .....</b>	<b>11</b>
Libero IDE Design Flow.....	12
<b>Project Files .....</b>	<b>18</b>
<b>Project Options.....</b>	<b>27</b>
<b>Settings.....</b>	<b>28</b>
Project Manager Project Settings.....	29
<b>Preferences.....</b>	<b>40</b>
<b>Project Manager Interface .....</b>	<b>46</b>
Libero IDE Project Manager.....	47
<b>Designing with Designer Block Components .....</b>	<b>59</b>
<b>Creating a Designer Block Component in Libero IDE .....</b>	<b>63</b>
Creating a Designer Block Component in Libero IDE .....	64
<b>Creating a Designer Block Component in Designer .....</b>	<b>68</b>
<b>Instantiating a Designer Block Component in Designer .....</b>	<b>72</b>
<b>SmartDesign.....</b>	<b>75</b>
General Questions .....	77
Instantiating your SmartDesign.....	78
Working with Processor-Based Designs in SmartDesign .....	79
Making your Design Look Nice .....	80
Generating your Design.....	81
General Questions .....	82
Instantiating Your SmartDesign.....	83
Working with Processor-Based Designs in SmartDesign .....	85
Making your Design Look Nice .....	86
<b>Getting Started with SmartDesign.....</b>	<b>88</b>

<b>SmartDesign User Interface</b> .....	94
<b>Canvas View</b> .....	95
<b>Grid</b> .....	108
<b>Instance-Instance View</b> .....	114
<b>Schematic View</b> .....	124
<b>Creating a SmartDesign</b> .....	126
<b>Connecting Instances</b> .....	128
<b>Bus Interfaces</b> .....	130
<b>Incremental Design</b> .....	143
<b>Reference</b> .....	149
<b>Welcome to Designer</b> .....	178
<b>Device Selection</b> .....	187
Device Selection Wizard.....	188
<b>Design Constraints</b> .....	213
Constraint Entry.....	215
<b>Families Supported</b> .....	221
Constraint Support by Family .....	222
Constraint File Format by Family .....	226
<b>Entering Constraints</b> .....	228
<b>Running Layout</b> .....	229
<b>Device Programming</b> .....	287
<b>Generating Programming Files</b> .....	288
<b>TCL Command Reference</b> .....	324
Introduction to Tcl Scripting.....	325
<b>Project Manager Tcl Commands</b> .....	350
set_root .....	387

<b>Reference .....</b>	<b>621</b>
<b>Dialog Boxes .....</b>	<b>623</b>
<b>Product Support .....</b>	<b>633</b>



# What's New in Libero IDE v9.1

## SmartFusion 060 Device Support

SmartFusion 060 device support is now enabled in software.

Family	Die	Package	Speed	Core Volt	Temp	Platinum
SmartFusion	A2F200M3F_060	256 FBGA	STD	1.5V	COM, IND	YES
			-1			
		288 CS	STD			
			-1			

## Creating Local Clock Regions in MultiView Navigator

For **IGLOO**, **Fusion**, **ProASIC3**, and **Axcelerator** families, you can use a PDC file to create local clock regions.

For **ProASIC PLUS** and **ProASIC** families, you can create local clock regions in ChipPlanner or define them in a GCF file. See the *Floorplanning ProASIC/ProASIC PLUS Devices for Increased Performance* application note for more information.

For Axcelerator, you can create local clock regions in ChipPlanner or define them in a PDC file.

When you create a local clock region, the selected net and all the macros driven by that net are assigned to the local clock region.

See the [Create Local Clock Regions in MVN topic](#) for instructions on how to use the new feature.

## Libero IDE Tool Updates

Libero IDE v9.1 includes support for new versions of ModelSim, Synplify, and Identify. New licenses are required for the updated OEM tools. See the release notes for the information on the latest version of the IDE software.

# Supported Families

Actel's Libero® Integrated Design Environment (IDE) and Designer software support the following families of devices:

- IGLOO®
- ProASIC3
- SmartFusion
- Fusion
- ProASIC<sup>PLUS</sup>
- ProASIC
- Accelerator
- eX
- SX-A
- MX
- RTAX-S/SL
- RTSX-SU

When we specify a family name, we refer to the device family and all its derivatives, unless otherwise specified. See the table below for a list of supported device families and their derivatives:

Table 1 · Actel's Product Families and Derivatives

Device Family	Family Derivatives	Description
<a href="#">IGLOO</a>	IGLOO	The ultra-low-power, programmable solution
	IGLOOe	Higher density IGLOO FPGAs with six PLLs and additional I/O standards
	IGLOO nano	The industry's lowest power, smallest size solution
	IGLOO PLUS	The low-power FPGA with enhanced I/O capabilities
<a href="#">ProASIC3</a>	ProASIC3	The low-power, low-cost, FPGA solution
	ProASIC3E	Higher density ProASIC3 FPGAs with six PLLs and additional I/O standards



Device Family	Family Derivatives	Description
	ProASIC3 nano	Lowest cost solution with enhanced I/O capabilities
	ProASIC3L	The FPGA that balances low power, performance, and low cost
	Automotive ProASIC3	ProASIC3 FPGAs qualified for automotive applications
	Military ProASIC3/EL	Military temperature A3PE600L, A3P1000, and A3PE3000L
	RT ProASIC3	Radiation-tolerant RT3PE600L and RT3PE3000L
<a href="#">SmartFusion</a>	SmartFusion	SmartFusion intelligent mixed-signal FPGAs are the only devices that integrate an FPGA, ARM Cortex-M3, and programmable analog, offering full customization and IP protection.
<a href="#">Fusion</a>	Fusion	Mixed-signal FPGA integrating ProASIC3 FPGA fabric, programmable analog block, support for ARM® Cortex™-M1 soft processors, and flash memory into a monolithic device.
<a href="#">ProASIC<sup>PLUS</sup></a>	ProASIC <sup>PLUS</sup>	Second-generation, high-density programmable flash devices with ASIC capabilities in a single-chip (75 k to 1 million gates)
ProASIC	ProASIC	This family has been discontinued and it is not recommended for new designs
<a href="#">Axcelerator</a>	Axcelerator	Nonvolatile, high-speed antifuse FPGAs with FuseLock™ design security and embedded FIFO controller (125 k to 2 million gates)
<a href="#">eX</a>	eX	Third-generation, low power, low density antifuse devices based on the SX-A architecture with greater than 350 MHz performance (3 k to 12 k gates)

Supported Families

Device Family	Family Derivatives	Description
<a href="#">SX-A</a>	SX-A	Antifuse devices with 270 MHz system performance and sea-of-modules architecture enabled by Actel's patented metal-to-metal antifuse interconnect elements (12 k to 108 k gates)
<a href="#">MX</a>	MX	Antifuse devices with 250 MHz system performance and MultiPlex I/O, an architectural feature that supports mixed-voltage systems and delivers high-performance operation at 5.0 V (3 k to 54 k gates)
<a href="#">RTAX-S/SL</a>	RTAX-S/SL	New generation of high-reliable, radiation-tolerant, antifuse-based FPGAs, designed for space applications with greater than 350 MHz system performance (250 k to 4 million system gates)
<a href="#">RTSX-SU</a>	RTSX-SU	High-reliable, radiation-tolerant antifuse-based FPGAs with 250 MHz system performance (48 k to 108 k system gates)

---

# Project Management

## Libero IDE Design Flow

**The Libero IDE Design Flow consists of six steps:**

### Step One - Design Creation

Plan out your design and use the Design Entry tools (such as [SmartDesign](#)) to enter it as either HDL (VHDL or Verilog), structural schematic, or mixed-mode (schematic and RTL).

### Step Two - Design Verification - Functional Simulation

After you have defined your design, you must verify that it functions the way you intended. After creating a testbench using [WaveFormer Pro](#), use the ModelSim VHDL or Verilog simulator to perform [functional simulation](#) on your schematic or HDL design.

If you have an EDIF netlist created with the full version of ModelSim you can import the netlist into your project and skip directly to Design Implementation (step four).

**EDIF Flow Support** - You can import an EDIF netlist in Project Manager. If you do not have HDL source files in your project, the EDIF netlist is considered to be a source for the flow.

The name of your block as specified in the EDIF netlist is displayed in the Hierarchy under the work library and is automatically Set as Root. The Project Flow Window is updated to show the EDIF flow: synthesis is unavailable and you can go directly to Designer or to Simulation as you would do in the post-synthesis state of the regular HDL flow. If you launch ModelSim, Project Manager automatically creates an HDL netlist.

The Configure Project Flow dialog does not allow you to activate synthesis.

As soon as you import an HDL Source file, the Hierarchy tab does not display the EDIF netlist any more and the Project Flow Window is updated to show the regular HDL flow.

**Note:** Note: If you have a regular HDL project with a synthesized EDIF netlist and remove all the source files from your project, the Project Design Flow will be changed to the EDIF flow and the EDIF netlist will appear in the Design Hierarchy.

### Step Three - Synthesis/EDIF Generation

Use Synplify Pro AE to generate your EDIF netlist. You can re-verify your design "post-synthesis" using the VHDL or Verilog ModelSim simulator used in step two.

While all RTL code must be synthesized, pure schematic designs are automatically "netlisted" out via the Libero IDE tools to create a structural VHDL or structural Verilog netlist.

### Step Four - Design Implementation

After you have functionally verified that your design works, the next step is to implement the design using the Actel [Designer](#) software. The Designer software automatically places and routes the design and returns timing information.

Use the tools that come with Designer to further optimize your design. Use [SmartTime](#) to perform static timing analysis on your design, [ChipEditor](#) or [ChipPlanner](#) to customize your I/O macro placement, MultiView Navigator for I/O customization, [SmartPower](#) for power analysis, and NetlistViewer to view your netlist.

### **Step Five - Timing Simulation**

After you are done with design implementation, you can verify that your design meets timing specifications. After creating a testbench using [WaveFormer Pro](#), use the ModelSim VHDL or Verilog simulator to perform [timing simulation](#).

### **Step Six - Device Programming**

Once you have completed your design, and you are satisfied with the timing simulation, create your programming file. Depending upon your device family, you need to generate a [Fuse](#), [Bitstream](#), or STAPL programming file.

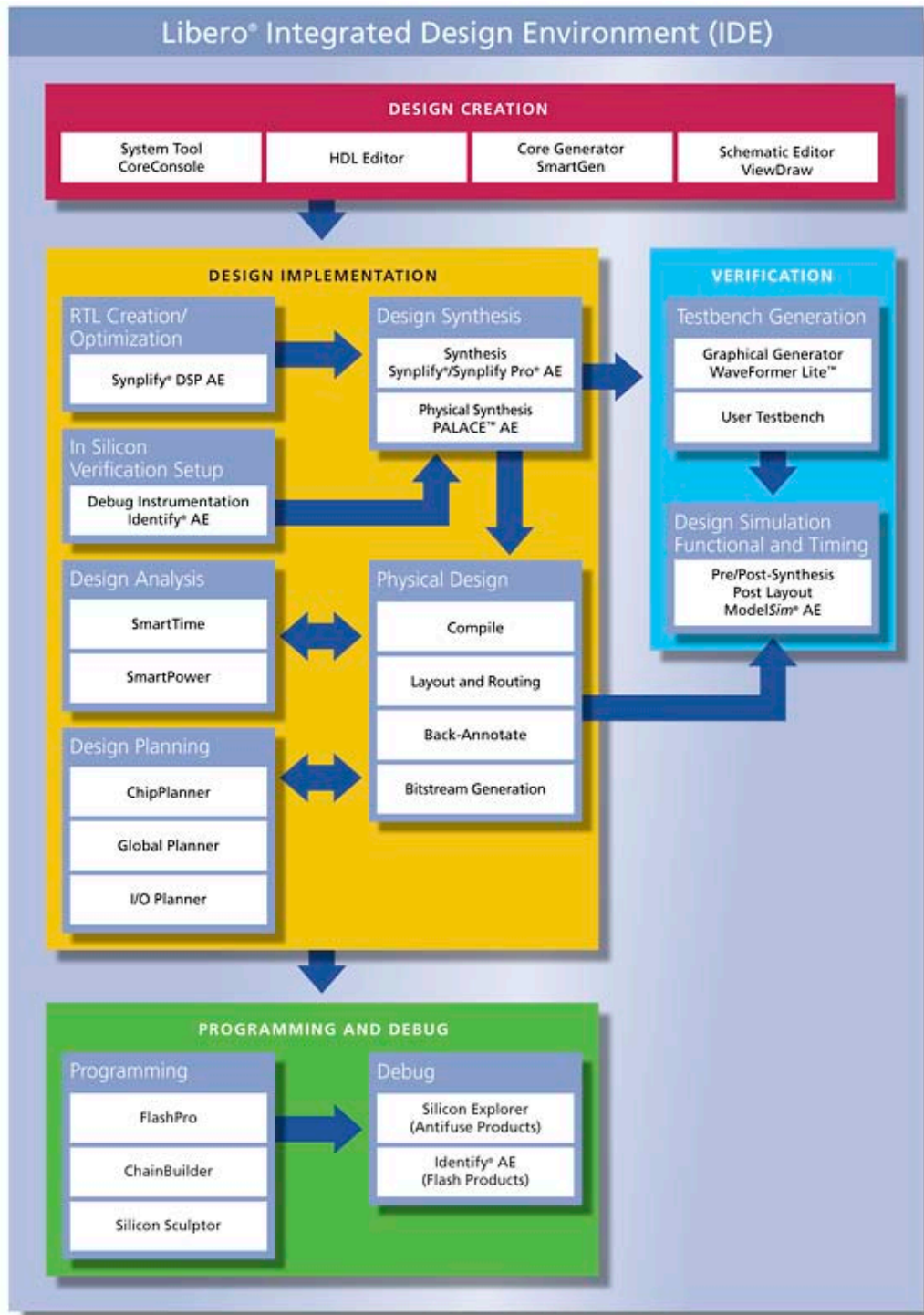

Figure 1 · Libero IDE Design Flow

## Creating a New Libero IDE Project

Use the New Project Wizard to create a new Libero IDE project in the Project Manager.

### **To create a new project:**

1. From the **File** menu, choose **New Project**. The New Project Wizard starts
2. Follow the instructions in the Wizard and click **Finish** when done.

You must select a new family in order to complete the New Project Wizard and create a new project.

You may set the die and package now, or do it later in the design flow.

### **See Also**

[Opening a project](#)

[Saving a project with a new name](#)

[new\\_project](#)

## Opening your Libero IDE project

The Project Manager opens your most recent project automatically. You can change your default startup preferences in the [Startup tab](#).

### **To open a different project in Project Manager:**

1. From the **File** menu, choose **Close Project**.
2. From the **File** menu, choose **Open Project** or **New Project**. If you create a new project the Project Manager starts the **New Project Wizard**.

**Tip** The last five saved projects are available from the File menu. From the **File** menu, choose **Recent Projects**, and then select the project to open.

You can open an existing project by double-clicking the \*.prj file or dragging the \*.prj file over the Libero IDE desktop icon.

### **See Also**

[open\\_project](#)

## Designer Views in the Project Manager

Designer views enable you to save different views and backup files for individual projects. You can use views to test different layout runs for a particular project.

You can also check your layout results for each Designer view; to do so, create as many views as you wish, and select them from the **Current Designer view** drop-down menu (available in the Designer Views Toolbar) and run layout.

### **To create a new Designer view:**

Click the Add Designer view button on the Designer Views toolbar, or from the Current Designer view menu, select Add. The Add Designer View dialog box appears, as shown in the figure below.

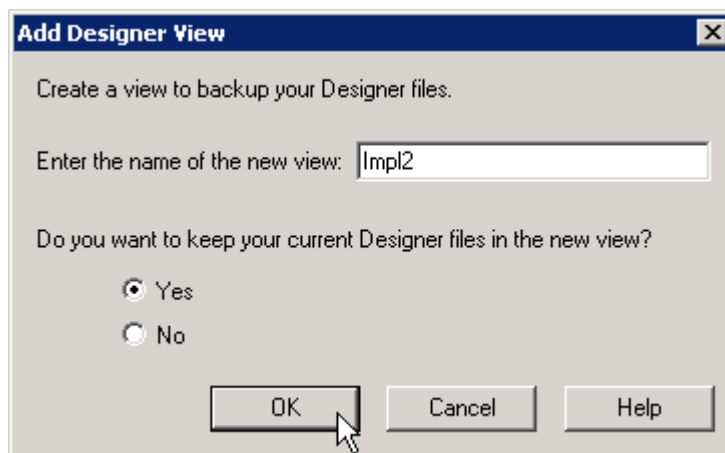

Figure 2 · Add Designer View Dialog Box

You can use your new Designer view to backup your current implementation files. Enter the name of your new view, and choose to keep your current implementation files or revert to the Project Manager defaults. Click OK to continue.

Your new Designer view appears in the list of views on the Designer Views toolbar.

### See Also

[Project Manager Project menu](#)

## Saving a Project with a New Name

Your project is saved when you close the project. To save the project with another name, use the **Save Project As** command.

### **To save the project with a new name:**

1. From the **Project** menu, choose **Save Project As**. The Save Project As dialog box opens.



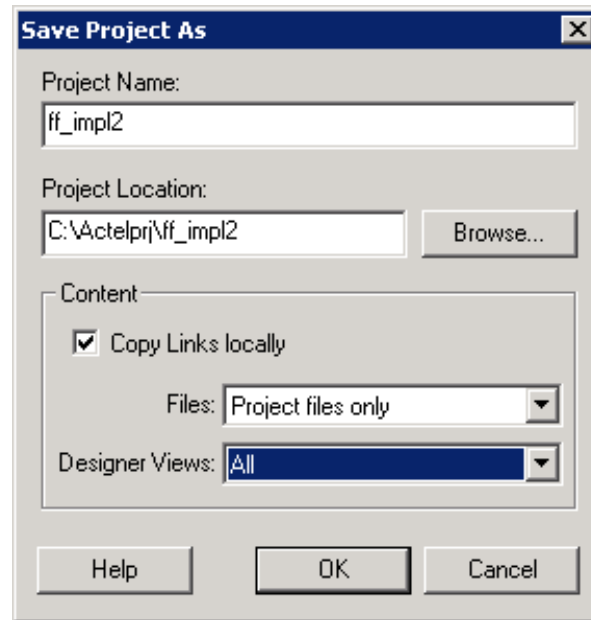

Figure 3 · Save Project As Dialog Box

2. Enter a new project name.
3. Enter a new project location, or click **Browse** to specify a new location.
4. Select the **Copy Links locally** checkbox if you have files linked to your current project and want to copy the links into your new project.
5. Specify which Files (**All**, **Project files only**, or **None**) and Designer Views (**All**, **Current view only**, or **None**) to copy into the new project.
6. Click **OK**.

### See Also

[save\\_as\\_project](#)

## Closing and Exiting

Your project is automatically saved when closed. To explicitly save your project, use **File > Save Project**. To save it with another name, use the [Save Project As](#) command.

To close a project, from the **Project** menu, choose **Close Project**.

To exit Libero IDE, from the **Project** menu, choose **Exit**.

### See Also

[Creating a new project](#)

[Opening a project](#)

[Saving a project with a new name](#)

# Project Files

## Project Sources

Project sources are any design files that make up your design. These can include schematics, HDL files, simulation files, testbenches, etc. Anything that describes your design or is needed to program the device is a project source.

Source files appear in the Project Flow window. The [Hierarchy](#) tab displays the structure of the design modules as they relate to each other, while the [Files](#) tab displays all the files that make up the project.

The design description for a project is contained within the following types of sources:

- Schematics
- HDL Files (VHDL or Verilog)
- SmartDesign components

One source file in the project is the top-level source for the design. The top-level source defines the inputs and outputs that will be mapped into the devices, and references the logic descriptions contained in lower-level sources. The referencing of another source is called an *instantiation*. Lower-level sources can also instantiate sources to build as many levels of logic as necessary to describe your design.

## File Linking

The Project Manager enables you to link to files not managed in your Libero IDE project. Linked files are useful if you want to preserve a file in an archive, or if more than one person is using a file and it is impractical to store it on your local machine. If you link to external files and rename your project, the Project Manager asks if you want to copy the external files into your project or continue using the link. Note that some files (such as schematics) cannot be linked.

Some project sources can be [imported](#).

Sources for your project can include:

Source	File Extension
Schematic	*.1-9
Verilog Module	*.v
VHDL Entity	*.vhd
SmartDesign Component	*.vhd
Testbench	*.vhd
Stimulus	*.tim

Source	File Extension
Programming Files	*.afm; *.prb

### See Also

[Creating a Schematic Source file](#)

[Creating HDL Sources](#)

[Generating a Bitstream file](#)

[Generating a Fuse file](#)

[Generating Programming files](#)

## New Files

You can create new files from the Project Manager. New file types include:

- Schematic
- SmartDesign Component
- CoreConsole Component
- IP Component
- VHDL Source File
- Verilog Source File
- Stimulus
- Stimulus HDL File
- SDC File (sdc)
- Physical Design Constraint File (pdc)
- DO File
- VHDL Template
- Verilog Template

### To create a new file:

1. From the **File** menu, choose **New**.
2. Select the File type and type a name.
3. Click **OK**. The appropriate application starts. The saved file is added to your Libero IDE project.

## Importing Files

Anything that describes your design, or is needed to program the device, is a project source. These may include schematics, HDL files, simulation files, testbenches, etc. Import these source files directly into your .

### To import a file:

1. From the **File** menu, choose **Import Files**.
2. In **Files of type**, choose the file type.
3. In **Look in**, navigate to the drive/folder where the file is located.
4. Select the file to import and click **Open**.

### Notes:

- You cannot import a Verilog File into a VHDL project and vice versa.
- CoreConsole components include all the files needed by the Project Manager in your project folder. Libero IDE lists the CoreConsole component in the Project Manager along with its files (each core includes its own block symbol files, HDL source files, constraint files, implementation files, memory files, etc.).
- When you import a CoreConsole component, the Project Manager creates a new directory in your project folder called *coreconsole* that includes all the required CoreConsole files. Project Manager preserves the structure of the original CoreConsole directory, except for the ViewDraw symbol - it gets copied into the *viewdraw* folder in your project.

## File Types for Import

File Type	File Extension
ViewDraw Symbol	*.1-9
ViewDraw Schematic	*.1-9
Behavioral and Structural VHDL; VHDL Package	*.vhd, *.vhdl
Design Block Core	*.gen
Verilog Include	*.h
Behavioral and Structural Verilog	*.v
Stimulus	*.vhd, *.vhdl, *.v
EDIF Netlist	*.edn

File Type	File Extension
CoreConsole Project (v1.1 and 1.2 only)	*.ccp
Simulation file required by CoreConsole	*.bfm
Memory file	*.mem
Components (Designer Blocks, Synplify DSP and CoreConsole components)	*.cxf

### See Also

[Project sources](#)

[import\\_files](#)

## Libero IDE file types

When you create a new project in the Libero IDE Project Manager it automatically creates new directories and project files. Your project directory contains all of your 'local' project files. If you [import](#) files from outside your current project, the files must be [copied into your local project folder](#). (The Project Manager enables you to manage your files as you import them.)

Depending on your project preferences and the version of Libero IDE you installed, the Project Manager creates directories for your project.

The top level directory (<project\_name>) contains your PRJ file; only one PRJ file is enabled for each Libero IDE project.

**component** directory - Stores your SmartDesign components (SDB and CXF files) for your Libero IDE project.

**constraint** directory - All your constraint files (SDC, PDC, GCF, DCF, etc.)

**coreconsole** directory - Default directory for all the CoreConsole files created in your Libero IDE project.

**designer** directory - ADB files (Actel Designer project files), \*\_ba.SDF, \*\_ba.v(hd), STP, PRB (for Silicon Explorer), TCL (used to run designer), impl.prj\_des (local project file relative to revision), designer.log (logfile)

**Note:** Note: The Actel ADB file memory requirement is equivalent to 2x the size of the ADB file. If your computer does not have 2x the size of your ADB file's memory available, please make memory available on your hard drive.

**hdl** directory - all hdl sources. \*.vhd if VHDL, \*.v and \*.h if Verilog

**phy\_synthesis** directory - \*\_palace.edn, \*\_palace.gcf, palace\_top.rpt (palace logfile) and other files generated by PALACE

**simulation** directory - meminit.dat, modelsim.ini files

**smartgen** directory - GEN files and LOG files from generated cores

**stimulus** directory - BTIM and VHD stimulus files

**synthesis** directory - \*.edn, \*\_syn.prj (Synplify log file), \*.psp (Precision project file), \*.srr (Synplify logfile), precision.log (Precision logfile), exemplar.log (Leonardo logfile), \*.tcl (used to run synthesis) and many other files generated by the tools (not managed by Libero IDE)

**viewdraw** directory - viewdraw.ini files

## Mixed-HDL Support in Libero IDE

You must have ModelSim PE or SE to use mixed HDL in the Libero IDE. Also, you must have Synplify Pro to synthesize a mixed-HDL design.

When you [create a project](#), you must select a preferred language. The HDL files generated in the flow (such as the post-layout netlist for simulation) are created in the preferred language.

The language used for simulation is the same language as the last compiled testbench. (E.g. if tb\_top is in verilog, <fam>.v is compiled.)

If your preferred language is Verilog, the post-synthesis and post-layout netlists are in Verilog 2001. You cannot import these netlists back into Designer; the Designer reader only accepts Verilog 95.

## Saving Files

Files and projects are saved when you close them.

### To save an active file:

- From the **File** menu, choose **Save** or **Save As**.
- Click the **Save**  button in the toolbar.

## Saving Files in the Libero IDE Project Manager

If you want to back up your Libero IDE Project Manager PRJ, Designer ADB, or other Project Manager project files, create a new of your design. Do not use the Save As function in Designer. Instead, use Add Designer view in the Libero IDE Project Manager.

## Deleting Files

Files can be deleted from the current project or from the disk.

### To delete a file from the project:

1. Select the **Files** tab in the Design Explorer window.
2. **Right-click** the file and choose **Delete from Project**. The file remains on your disk.

**To delete a file from your project and the disk:**

1. Select the **Files** tab in the Design Explorer window.
2. **Right-click** the file and choose **Delete from Disk and Project**. The file is deleted from your disk and is no longer part of any project.

## Finding Files

Use the Find Window to search for files. Search options vary depending on your search type.

**To find a file:**

1. Use CTRL + F to open the Find Window toolbar.

Figure 4 · Find Window (Search in Files)

2. Select your search type: Files, Modules in Project, Find Ports in SmartDesign, Find Nets in SmartDesign, Find Instances in SmartDesign, or Find Text in Text Editor.
3. Enter the name or part of name of the object you wish to find.
4. Set the Options for your search (see below for list); options vary depending on your search type.
5. Click **Find** (or **Next** if searching Text). The results appear in the Find In Files tab in the Log window (as shown in the figure below), on the Canvas if you search in SmartDesign, or in a new pane if you are searching Modules. Click the file name in the Log window to open the file.

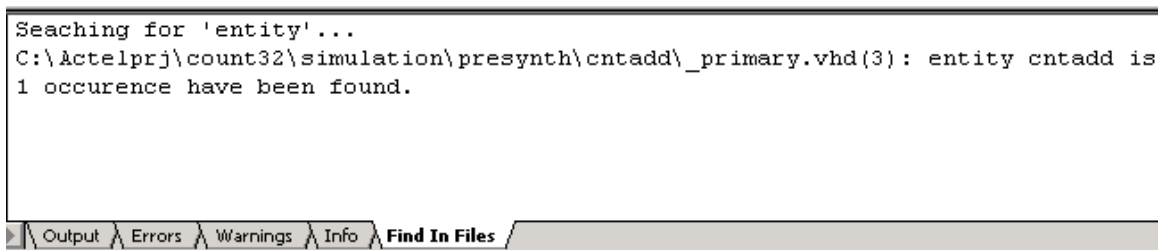

Figure 5 · Find In Files Tab in Project Manager Log Window

### Search in Files (Files button)

**Match case:** Select to search for case-sensitive occurrences of a word or phrase. This limits the search so it only locates text that matches the upper- and lowercase characters you enter.

**Match whole word:** Select to match the whole word only.

**In files/file types:** Select a file type to narrow your search.

**In folder:** Select a folder. Click the browse button to navigate to a different folder.

## Search Modules in Project (Modules button)

**Match case:** Select to search for case-sensitive occurrences of a word or phrase. This limits the search so it only locates text that matches the upper- and lowercase characters you enter.

**Match whole word:** Select to match the whole word only.

**Overwrite previous results:** Clears the contents of the Log window and writes the new results.

**Append to previous results:** Appends the new results to the contents of the log window. This option is useful if you are running several searches in succession and want to export the results.

**Existing Pane:** Displays your search results in an existing pane in the Log window.

**New Pane:** Displays your search results in a new pane in the Log window with a name you specify.

## Find Ports / Find Nets / Find Instances in SmartDesign

These searches are available only when you have a SmartDesign open. SmartDesign highlights your search results for ports / nets / instances on the Canvas.

**Match case:** Select to search for case-sensitive occurrences of a port / net / instance. This limits the search so it only locates the objects that match the upper- and lowercase characters you enter.

**Overwrite previous results:** Clears any currently selected ports / nets / instances in your design before selecting the matching ports / nets/ instances.

**Append to previous results:** Appends any new matches to the currently selected ports / nets/ instances in your design.

## Find Text in Text Editor (Text button)

**Previous:** Proceed to previous instance of found text.

**Next:** Proceed to next instance of found text.

**Mark All:** Marks all instances of the found text.

**Match case:** Select to search for case-sensitive occurrences of a word or phrase. This limits the search so it only locates text that matches the upper- and lowercase characters you enter.

**Match whole word:** Select to match the whole word only.

**Replace with:** Replaces the text you searched with the contents of the field. Click Replace All to replace all instances of the found text with the contents of the field.

## Find Window

You can search for modules and components in the Hierarchy with the [Find window](#) (see figure below). You can search by name, library or type (All, Components, HDL modules, VHDL package and Schematic) and use wildcards to refine your search.



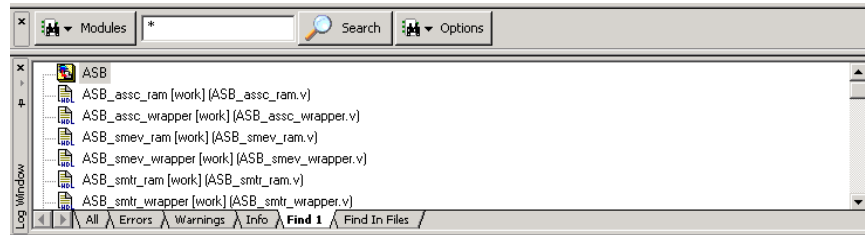



Figure 6 · Find Module/Component

**To find a module in the Hierarchy:**

In the Find window, enter the search criteria and click **Find Now**. The Project Manager displays the module in the **Find** tab in the **Log Window**.

## Linking files

You can add or change links for individual files in your project, or change all the links in your files at once.

To add a link to an individual file, right-click the file in the Design Explorer and choose **Create Link From File**. Navigate to the file you wish to link to your project and click Create Link. The Project Manager adds the file to your Design Explorer; a small link icon  indicates that the source file is not stored with the project.

If you have a single project file with a broken link , right-click the file and choose **Change Link**. This opens the Change Link dialog box and enables you to specify a new file location.

You can update all the links in your project at once. This is useful when you are linking to shared network folders that may have been renamed or moved. To change links for your entire project, from the **File** menu, choose **Change All Links**. This opens the [Change All Links dialog box](#). Enter (or browse) your old and new paths to update the links for your project.

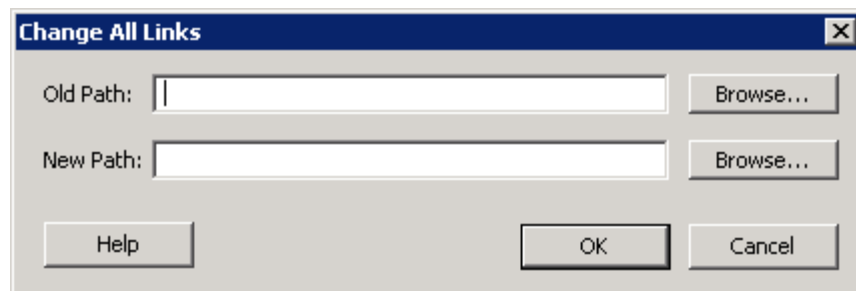

Figure 7 · Change All Links Dialog Box

To unlink a file, right-click the file in the Files tab and choose **Unlink: copy file locally**. This copies the file to the directory in your project folder that corresponds to the file type.

To unlink all files and copy them to your local project, from the **File** menu choose **Unlink All: Copy files locally**.

You can also change/remove links from the Design Explorer; to do so, right-click the file in the **Design Explorer > Modules defined in multiple files** and choose **Change Link**.

## Reserved Actel Keywords

For a complete list of reserved Actel keywords, see the online help.

## Project Options

### VHDL Library - Add, Remove, or Rename

Libero IDE enables you to manage your VHDL libraries from within the Project Manager.

From the Project menu, select **VHDL Library** and **Add**, **Remove**, or **Rename** to update your library.

When you add a library it appears in your Hierarchy.

---

# Settings

## Project Manager Project Settings

Use the Options dialog box to specify your project settings for the currently open project.

From the **Project** menu, choose **Settings** to open the dialog box. View and edit the preferences and click **OK**. To revert to the default settings, click **Default**.

Options include:

- [Project Settings: Device](#)
- [Project Settings: Flow](#)
- [Project Settings: Simulation](#)

## Project Settings: Device

Use the Device tab in the Project Settings dialog box to change the die and package for your project.

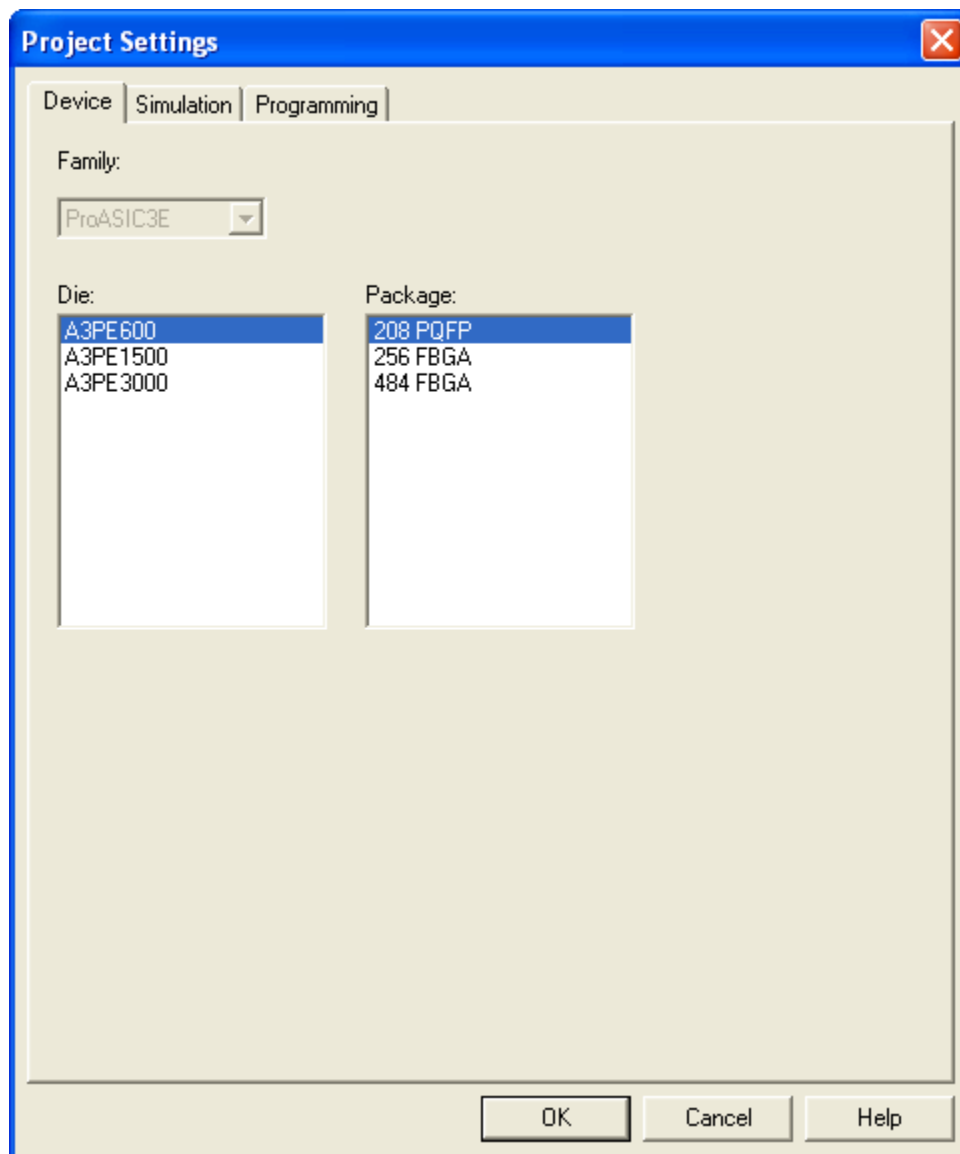

Figure 8 · Project Settings: Device Tab

You can use the Family Combo check box to change your family from ProASIC3 to ProASIC3E. No other family changes are enabled.

**To change the die and/or package:**

1. From the **Project** menu, choose **Settings**. The Project Settings dialog box appears.
2. Select a die and package from each list and click **OK**.

## Project Settings: Flow

Use the Flow tab in the Project Settings dialog box to configure your settings for HDL netlists, the DRC checker, ModelSim, ViewDraw, and the rest of your design flow.

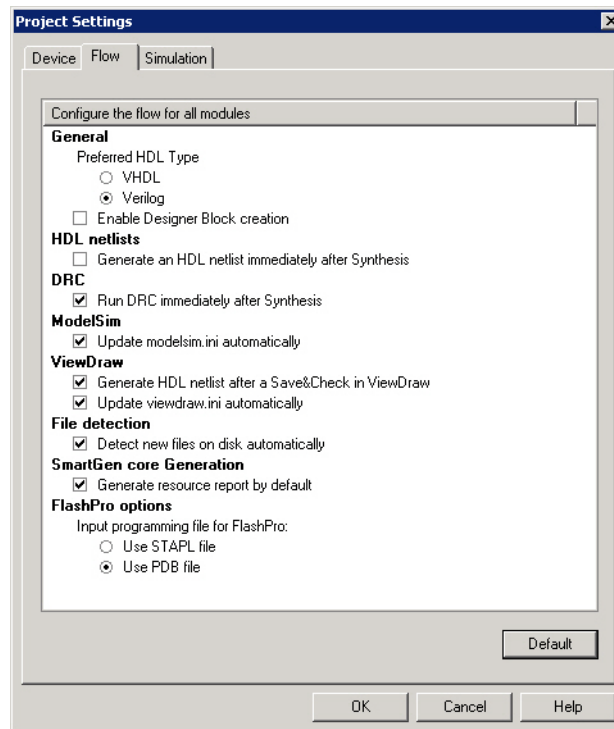

Figure 9 - Project Settings: Flow tab

### General

**Preferred HDL Type** - Set your HDL type to VHDL or Verilog.

**Enable Designer Block creation** - Enables you to create Designer Blocks in the Project Manager. Designer Blocks are useful if you want to create a block and re-use it in several designs. See the [Designer Block help](#) for more information.

### HDL Netlists

The HDL project level options enable you to specify whether or not you want to generate your HDL netlists after synthesis.

- **Generate an HDL netlist immediately after synthesis** - Select this option if you run post-synthesis simulation. If you do not run post-synthesis simulation, de-select this option to start Designer more quickly.

### DRC

**Run DRC immediately after synthesis** evaluates the netlist generated by Synplify to ensure it does not have any connection problems.

## ModelSim

Update modelsim.ini automatically may be useful if the Project Manager does not create a valid modelsim.ini file. Click the checkbox to enable.

## ViewDraw

**Generate HDL netlist after a Save&Check in ViewDraw** - Useful if you wish to eliminate the manual step of generating your HDL netlist after a Save&Check.

**Update viewdraw.ini automatically** - May be useful if the Project Manager does not create a valid viewdraw.ini file. Click the checkbox to enable.

## File Detection

**Detect new files on disk automatically** enables the Project Manager to see new files when you add them to your project. If you deselect this option, you must add the new files manually.

## SmartGen core Generation

**Generate resource report by default** creates and saves the Design Block (core) resource report after you generate a core.

## FlashPro options

Input programming file for FlashPro sets your input programming file. PDB files enable you to configure the security settings in FlashROM and Flash Memory from FlashPro.

## Project Settings: Simulation

Use the Simulation tab to set your simulation values in your project. You can set change how the Project Manager handles Do files in simulation, import your own Do files, set simulation run time, and change the resolution of your simulation. You can also change your library mapping in this dialog box.



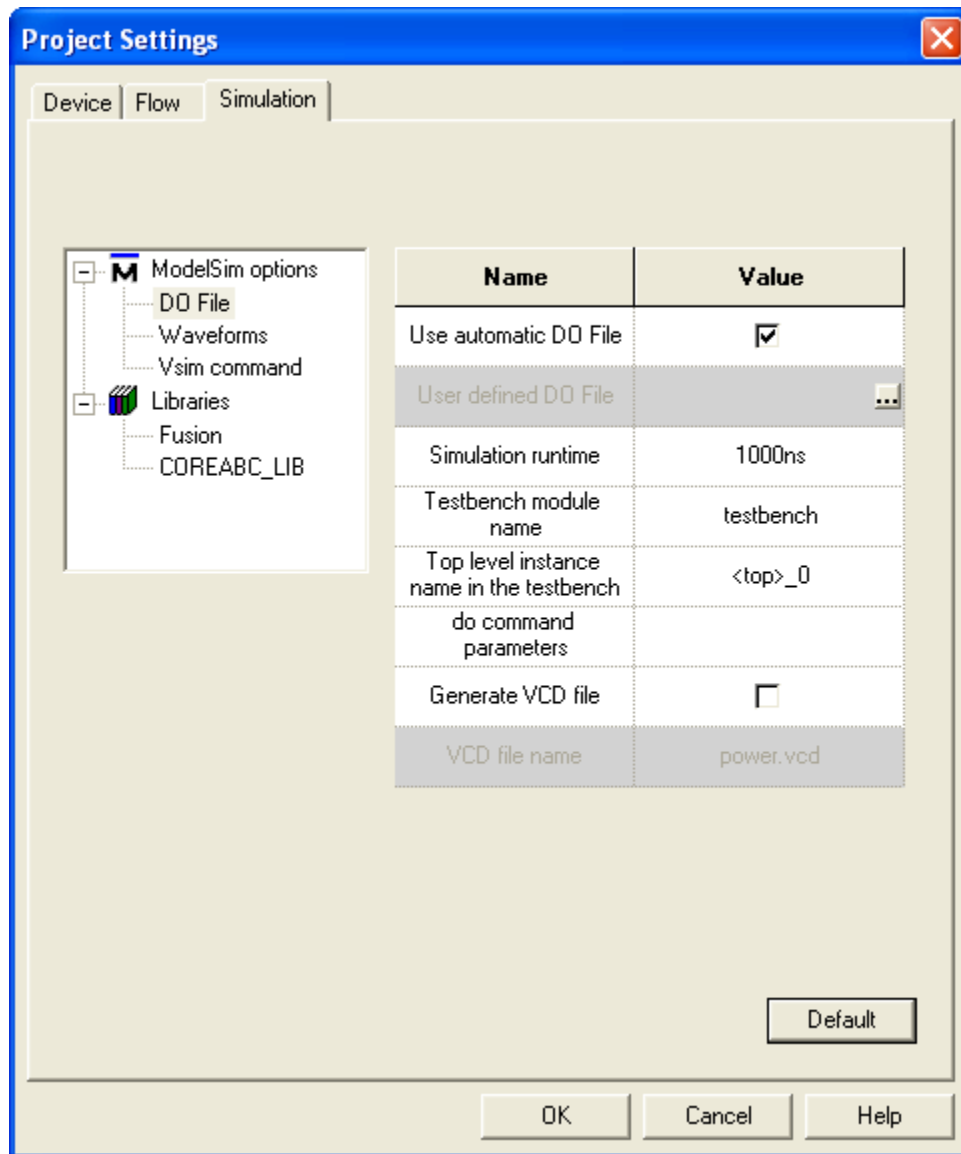

Figure 10 · Project Settings: Simulation Tab

## DO file

**Use automatic DO file** - Select if you want the Project Manager to automatically create a DO file that will enable you to simulate your design.

**User defined DO file** - Enter the DO file name or click the browse button to navigate to it.

**Simulation Run Time** - Specify how long the simulation should run. If the value is 0, or if the field is empty, there will not be a run command included in the run.do file.

**Testbench module/entity name** - Specify the name of your testbench entity name. Default is “testbench,” the value used by WaveFormer Pro.

**Top Level instance name in the testbench** - Default is <top\_0>, the value used by WaveFormer Pro. The Project Manager replaces <top> with the actual top level macro when you run ModelSim.

**DO command parameters** - Text in this field is added to the DO command.

**Generate VCD file** - Click the checkbox to generate a VCD file.

**VCD file name** - Specifies the name of your generated VCD file. The default is power.vcd; click power.vcd and type to change the name.

## Waveforms

**Include DO file** - Including a DO file enables you to customize the set of signal waveforms that will be displayed in ModelSim.

**Included DO File** - Use the browse button to navigate to the included DO file.

**Display waveforms for** - You can display signal waveforms for either the top-level testbench or for the design under test. If you select **top-level testbench** then Project Manager outputs the line 'add wave /testbench/\*' in the DO file run.do. If you select **DUT** then Project Manager outputs the line 'add wave /testbench/\*' in the run.do file.

**Log all signals in the design** - Saves and logs all signals during simulation.

## Vsim Command

**SDF timing delays** - Select Minimum (Min), Typical (Typ), or Maximum (Max) timing delays in the back-annotated SDF file.

### Resolution

The default is family specific, but you can customize it to fit your needs.

Family	Default Resolution
ACT1, ACT2, ACT3	1 ns
MX	1 ns
DX	1 ns
SX, SX-A	1 ns
eX	1 ns
Axcelerator	1 ps
ProASIC	1 ps
ProASIC <sup>PLUS</sup>	1 ps

Family	Default Resolution
ProASIC3	1 ps
ProASIC3E	1 ps
IGLOO	1 ps
IGLOOe	1 ps
Fusion	1 ps

**Vsim additional options** - Text entered in this field is added to the vsim command.

## Libraries

**Use default library path** - Sets the library path to the default from your Libero IDE installation.

**Library path** - Enables you to change the mapping for your VHDL library. Type in the pathname or click the Browse button to navigate to your library directory.

**Library command** - Select the radio button to ignore (Do not compile), Refresh, Compile the library, Delete and recompile, or Refresh and Compile the library.

To access this dialog, from the **Project** menu, choose **Settings** and then select the **Simulation** tab.

## Setting Your Project Profile

Each Libero IDE project can have a different profile, enabling you to integrate different tools with different projects.

### **To set or change your project profile:**

- From the **Project** menu, choose **Profiles**.
  - To add a tool:** Click **Add** and select which type of tool. Fill out the tool profile and click **OK**.
  - To change a tool profile:** After selecting the tool, click to **Edit** to select another tool, change the tool name, or change the tool location.
  - To remove a tool from the project:** After selecting a tool, click **Remove**.
- When you are done, click **OK**.

### **See Also**

[Add or Edit Profile dialog box](#)

[Starting LeonardoSpectrum](#)

[Starting Precision](#)

## Source Files for Synthesis

The Source Files for Synthesis dialog box enables you to set the synthesis file order in the Project Manager.

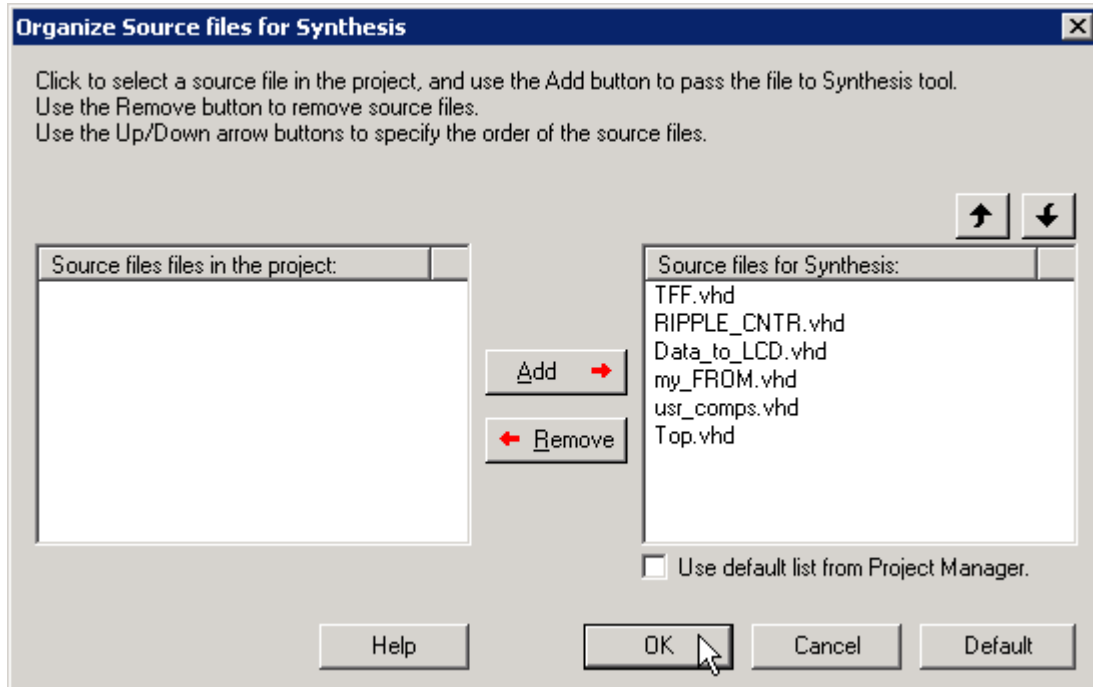

Figure 11 · Organize Source Files for Synthesis Dialog Box

De-select the Use default list from Project Manager checkbox to Add/Remove source files for synthesis.

### **To specify the synthesis file order:**

1. From the **Project** menu, choose **File Organization > Source Files for Synthesis**. The Organize Source Files for Synthesis dialog box appears.
2. De-select the **Use default list from Project Manager** checkbox to Add/Remove source files for synthesis. Click the **Default** button to reset the options to the original settings.
3. Click **OK**.

## Source Files for Simulation

The Source Files for Simulation dialog box enables you to set the simulation file order in the Project Manager.

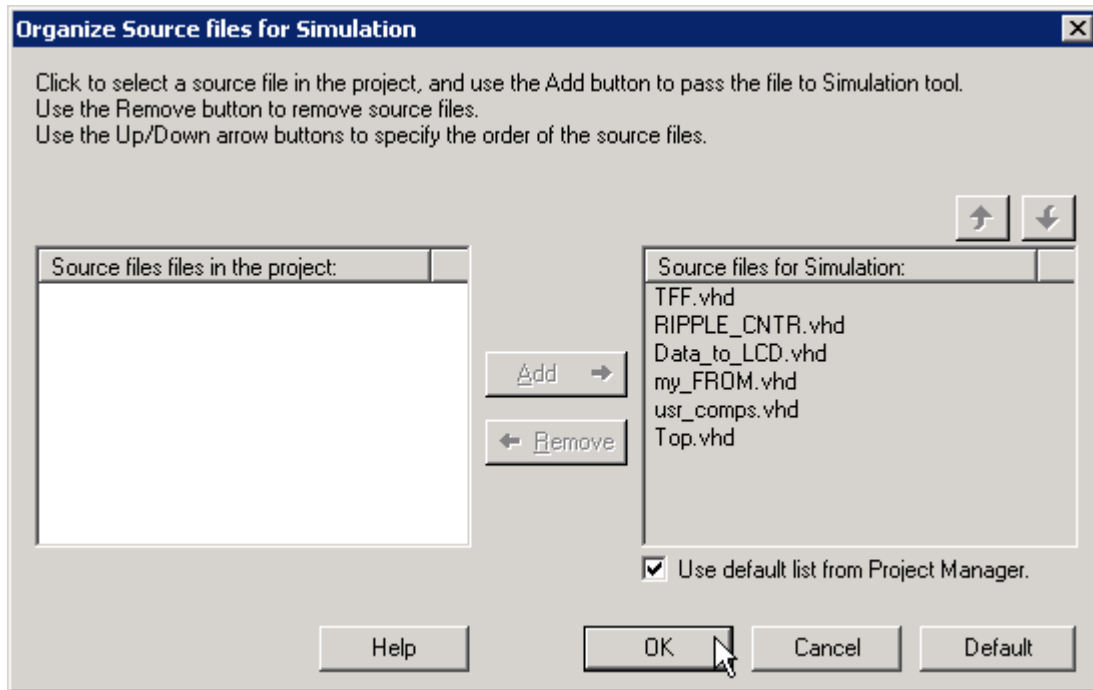

Figure 12 · Organize Source Files for Simulation Dialog Box

De-select the Use default list from Project Manager checkbox to Add/Remove source files for simulation.

**To specify the simulation file order:**

1. From the **Project** menu, choose **File Organization > Source Files for Simulation**. The Organize Source Files for Simulation dialog box appears.
2. De-select the **Use default list from Project Manager** checkbox to Add/Remove source files for simulation. Click the **Default** button to reset the options to the original settings.
3. Click **OK**.

## Designer Constraint File Organization

Use the Organize Constraints for Designer dialog box to specify the constraint files that you want Designer to use for your current module.

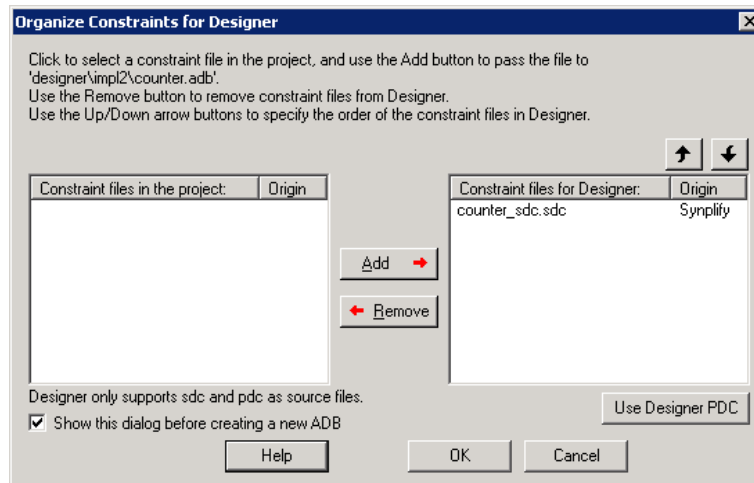

Figure 13 · Organize Constraints for Designer Dialog Box

You can also specify the order in which you want to import these files into Designer and consider dependencies between them.

To select constraint files for Designer, select a file in the *Constraint files in the project* list and click the **Add** button. Libero adds the file to the *Constraint files for Designer* list.

To remove constraint files from Designer, select a file in the *Constraint files for Designer* list and click the **Remove** button. The Project Manager removes the files from the *Constraint files for Designer* list.

Use the **Up** and **Down** arrow buttons to specify the order that you want your constraint files imported into Designer.

When a constraint file generated by a tool is added to the list of constraint files for Designer, it is added before any user constraint files. You can change the order of any file, but Actel recommends that you do not pass user constraint files before tool constraint files.

If you add both Synplify and PALACE constraint files to the list, the recommended (and default) order is:

1. Synplify constraint file
2. PALACE constraint files
3. User constraint files

[Use Designer PDC](#) - Enables you to export a PDC file from your design so you can use it for incremental flow. The Project Manager opens the ADB, exports a PDC file, and replaces all input PDC files with the updated version.

## Stimulus File Organization

Use the Organize Stimulus dialog box (below) to manage the stimulus files in your project.

Before you can run simulation, you must associate a testbench. If you attempt to run simulation without an associated testbench, the Project Manager asks you to associate a testbench or open *ModelSim* without a testbench. You can use the Organize Stimulus dialog box to set associate your testbench for simulation.

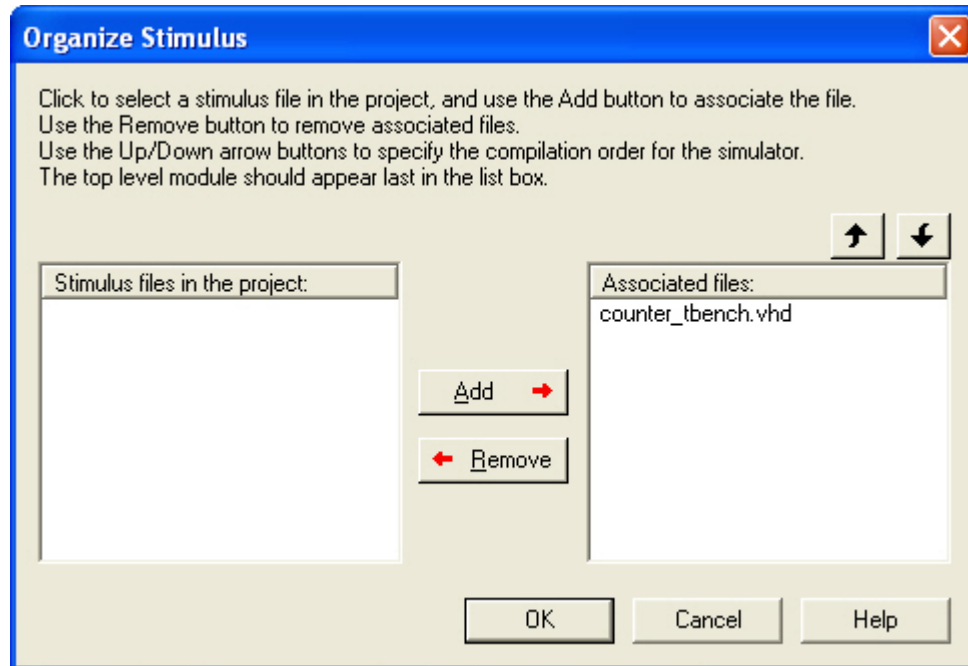

Figure 14 · Organize Stimulus Files Dialog Box

**To organize your stimulus files:**

1. From the **Project** menu, choose **File Organization > Stimulus**. This opens the **Organize Stimulus** dialog box.
2. In the Organize Stimulus dialog box, all the stimulus files in the current project appear in the *Stimulus Files in the Project* list box. Files already associated with the block appear in the *Associated Files* list box.

In most cases you will only have one testbench associated with your block. However, if you want simultaneous association of multiple testbench files for one simulation session, as in the case of PCI cores, add multiple files to the *Associated Files* list box.

**To add a testbench:** Select the testbench you want to associate with the block in the *Stimulus Files in the Project* list box and click **Add** to add it to the *Associated Files* list.

**To remove a testbench:** To remove or change the file(s) in the *Associated Files* list box, select the file(s) and click **Remove**.

**To order testbenches:** Use the up and down arrows to define the order you want the testbenches compiled. The top level-entity should be at the bottom of the list.

3. When you are satisfied with the Associated File(s) list, click **OK**. The stimulus buttons in the Project Manager Project Flow window turn green to alert you that a testbench has been associated with the block.

# Preferences

## Setting Preferences

Use the Preferences dialog to customize the Libero IDE Project Manager.

### **To set your preferences:**

1. From the **Project** menu, choose **Preferences**.
2. Specify your preferences on each of the tabs.

[Updates](#)

[Proxy Settings](#)

[Startup](#) (File association)

[Log](#)

[Text Editor](#)

[Advanced](#)

[PDF reader](#) (UNIX only)

[Web browser](#) (UNIX only)

3. Click **OK**.

**Note:** Note: These preferences are stored on a per-user basis. These preferences are not project specific.

## Updates

Actel strongly recommends that you check at least once a week for fixes, updates, and enhancements for your Actel software.

**Note:** Note: This feature requires an internet connection.

**Note:** The version checking feature is not available for Linux.

The Updates tab in the Preferences dialog box allows you to set your automatic software update preferences.

### **To set your automatic software update preferences:**

1. From the **Project** menu, choose **Preferences > Updates**.
2. Choose one of the following options:
  - Automatically check for updates at startup: Select to be notified of updates when you start Designer.
  - Remind me to check for updates at startup: Select to be asked if you want to check for a software update when you start Libero IDE.



- Do not check for updates or remind me at startup: Select if you do not want to check for software updates at startup.

To manually check for software updates, from the **Help** menu, choose **Check for Software Updates**, click **OK**.

## IP Updates

Set your IP update options. When downloaded, IP appears in the [Catalog](#).

### See Also

[Setting preferences](#)

## Setting Your Proxy

An FTP connection is used to update some data files. Use the Proxy tab in the Preferences dialog box to enter your proxy name if you use a proxy server.

1. From the **Project** menu, choose **Preferences**.
2. Click the **Proxy** tab.
3. If you use a Proxy server, click the check box and enter the name.
4. Click **OK** to dismiss the Preferences dialog box.

### See Also

[Version Checking](#)

## Startup Tab

Several programs, including the Libero IDE Project Manager, create files with the PRJ extension. If you want the Project Manager to start whenever you double-click a PRJ file, you need to set up Project Manager as the default editor for PRJ files.

You must have rights to modify the HKEY\_CLASSES\_ROOT of the registry of the machine to set Libero IDE Project Manager file association. If you do not have rights to modify the registry, Libero IDE ignores your settings.

### **To make the Project Manager the default editor for PRJ files:**

1. From the **Project** menu, choose **Preferences**.
2. Click the **Startup** tab.
3. Select the check box to associate Libero IDE Project Manager with PRJ files.

### **To open the most recently used project at startup:**

1. From the **Project** menu, choose **Preferences**.
2. Click the **Startup** tab.
3. Select the check box to open the most recently used project at startup.

## Setting Your Log Window Preferences

Errors, Warnings, and Informational messages are color-coded in the Project Manager log window. You can change the default colors by using the log Window tab in the Preferences dialog box.

### Window Colors

#### **To change colors in the log window:**

1. From the **Project** menu, choose **Preferences**.
2. Click the **Log Window** tab in the Preferences Dialog Box.
3. Select your new default colors and click **OK**.

Click the Restore Defaults button to reset the log window colors to their original settings.

The default color settings for the log window are:

Message Type	Colors
Errors	Red
Warnings	Light Blue
Informational	Black
Links	Dark Blue

**Clear log window automatically** - (unchecked by default) Clears the Project Manager log window each time you close or open a new project. Clear the box if you want Project Manager to leave the log information after you close a project.

### Log Size

Sets a maximum log buffer size for your log window. Uncheck the box for no limit on size; click the Restore Default button to reset the buffer size to its original setting.

## Text Editor

You can use the Libero IDE HDL text editor or another text editor.

#### **To set your text editor preferences:**

1. From the **Project** menu, choose **Preferences**.
2. Click **TextEditor**.

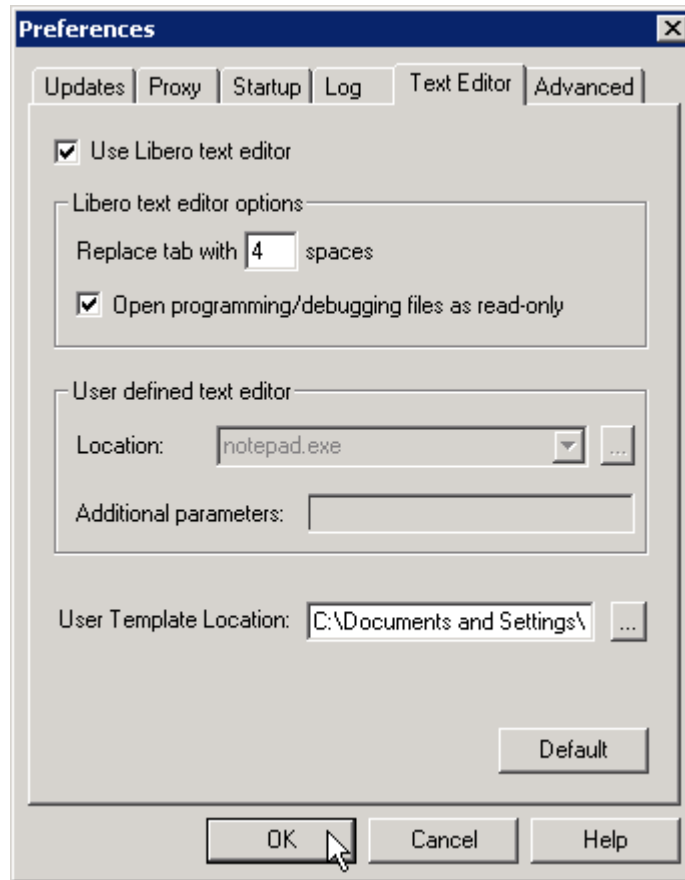

Figure 15 · Preferences: Text Editor

2. Set your options and click **OK**.

**Libero text editor options**

- **Use Libero text editor:** Select to use the Libero HDL text editor.
- **Replace tab with spaces:** Enter the number of spaces you want entered when using the tab key.
- **Open programming/debugging files as read-only:** Select to specify read-only permission to .stp and .prb files.

**User defined text editor**

- **User defined text editor:** Deselect use Libero text editor to activate this area. Enter the .exe location of the text editor.
- **Additional parameters:** Use to specify other settings to pass to the text editor. Typically, it is not necessary to modify this field.

**User Template Location** - Sets the path where your user templates are exported

## Advanced (Libero IDE Project Manager)

The Advanced tab in the Project Manager preferences dialog box sets Designer and HDL options. To open the Advanced tab, from the **Project** menu, choose **Preferences** and click the **Advanced** tab.

### Designer Options

**Organize constraint files before running synthesis** - When this option is enabled, the Organize Constraints dialog box automatically opens before your synthesis tool UI appears. This dialog enables you to select the constraint files that will be passed your synthesis tool.

**Organize constraint files before creating a new ADB** - When this option is enabled, the Organize Constraints for Designer dialog box automatically opens before the Designer UI. This dialog enables you to select the constraint files that will be passed to Designer. The purpose of this option is to enable you to organize your constraint files before creating a new ADB.

**Organize CDB files before creating a new ADB** - When this option is enabled, the Organize Constraints dialog box automatically opens before the Designer UI. This dialog enables you to select the CDB files that will be passed to Designer. The purpose of this option is to enable you to organize your CDB files before creating a new ADB.

**Warn me when Designer Block mode is changed** triggers an automatic warning when you enable/disable [Designer Block mode](#). Designer Block mode has limitations that may affect your design if you enable/disable the mode accidentally. Deselect this option to disable the warning.

### HDL Templates

**Warn me when templates are only copied to the clipboard** enables a warning when you do not have an open HDL file and the template is copied to the clipboard. You must open an HDL file and past the clipboard contents manually. Deselect this option to disable the warning.

### IP Cores

**Warn me before:**

**Simulation of the wrapper of an IP core** - Simulation of the top-level wrapper is incomplete relative to simulation of the core itself. Click the checkbox to enable a warning when you simulate a wrapper. Actel recommends that you run simulation on the core, and run synthesis on the wrapper (see warning below).

**Synthesis of an IP core** - Synthesis of the core is incomplete relative to synthesis of the wrapper. Click the checkbox to enable/disable a warning if you synthesize an IP core instead of the wrapper. Actel recommends that you run synthesis on the wrapper, and run simulation on the core (see warning above).

**Launching a tool on a component with errors** - De-select this option to prevent warnings when you launch a tool on a component that has errors in it. This may be useful if you wish to leave some elements of the component incomplete and finish them at a later time. If you de-select this option, you will not have to see a warning every time you open the component.

**Launching a tool on an out of date component** - De-select this option if you do not wish to see warning messages related to out of date components. A component is out of date if a newer version is available.

**Warn me when:**

**A project is open and new cores are available** - Shows the New Cores Available message when new cores are available for download. Deselect this option to hide the messages.

**I instantiate a core that has a newer version** - Shows a warning when you instantiate a core that has a newer version available for download.

## Environment Variables

The software included with the Libero IDE sets new environment variables during installation. They are summarized below.

### Libero IDE/Designer - System Variables:

PATH: <Libero install directory>\Designer\bin

PATH: <Program Files>\Common Files\Actel

**Note:** Note: Program Files can be set on C:, D:, etc. it depends on the setting on your system's environment settings.

### ViewDraw - User Variables:

PATH: <Libero install directory>\ViewDraw\bin

PATH\_Old: <a copy of original PATH. If there was no existing PATH when ViewDraw was installed, ViewDraw still creates this variable with an empty value>

ACTELWDIR: <Libero install directory>\ViewDraw\bin

ACTELWDIR\_OLD: <a copy of original ACTELWDIR. If ACTELWDIR did not exist when ViewDraw was being installed, the value of this variable is just a copy of ACTELWDIR>.

### Palace - System Variables:

PALACE\_ROOTDIR: <Libero install directory>\PALACE

PATH: <Libero install directory>\PALACE\bin

### ModelSim -System Variables:

PATH: <Libero install directory>\Model\win32acoem

---

# **Project Manager Interface**

## Libero IDE Project Manager

The Libero IDE Project Manager workspace integrates [design tools](#), streamlines the design flow, manages all design and log files, and passes design data between tools.

The Design Explorer Window includes the [Hierarchy](#), [Files](#), and Information windows.

At right are the [Project Flow Window](#), the [HDL Editor](#), and [SmartDesign](#). The [Catalog](#) window lists all IP Cores, VHDL and Verilog Templates, and Bus Interface definitions.

The default location for the [Find](#) and [Log](#) windows is below the Project Flow Window.

You can customize the Project Manager interface to meet your needs. Close or reposition the Design Explorer, Catalog, Information, Find, and Log windows with the control buttons in the top right of each window; the pin shrinks the window into an expandable bar on the left, the arrow collapses/expands the docked window, and the X closes it.

To re-open a closed window, from the View menu, choose View > Toolbars > <name of window>.

The Project Manager also includes [toolbars and menus](#).

### See Also

[Creating a new project](#)

[Files tab](#)

[Navigating the work environment](#)

[Project Settings](#)

## Hierarchy in the Design Explorer

The Hierarchy tab displays a hierarchical representation of the design based on the source files in the project. The Project Manager continuously analyzes and updates source files and updates the hierarchy. The Hierarchy tab (see figure below) displays the structure of the modules and components as they relate to each other.

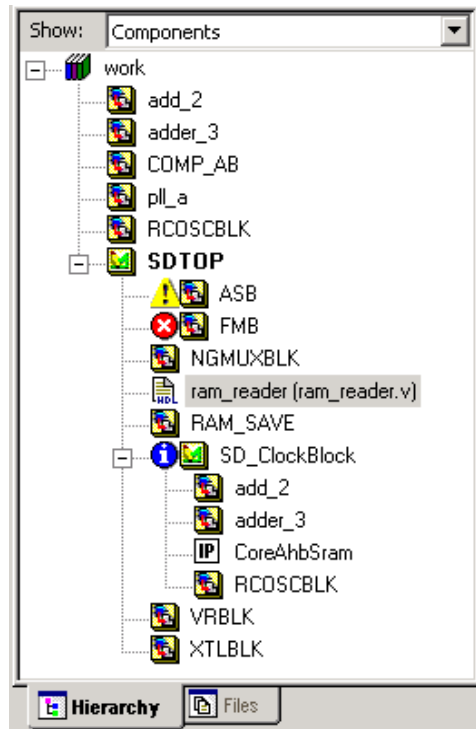

Figure 16 · Hierarchy

You can change the display mode of the Hierarchy by selecting **Components** or **Modules** from the **Show** drop-down list. The components view displays the entire design hierarchy; the modules view displays only schematic and HDL modules.

The file name (the file that defines the block) appears next to the block name in parentheses.

More information about the block can be found by right-clicking it and selecting **Properties**. The Block Properties dialog box displays block properties including, file path, created date, and last modified date.

All integrated source editors are linked with the Project Manager. If a source is modified and the modification changes the hierarchy of the design, the Design Hierarchy automatically updates to reflect the change.

If you want to update the design hierarchy, from the **Edit** menu, choose **Refresh**.

#### **To open a component:**







Double-click a component in the Hierarchy to open it. Depending on the block type and design state, several possible options are available from the right-click menus. You can [instantiate a component](#) from the Hierarchy to a [SmartDesign](#) window.

Icons in the Hierarchy indicate the type of component and the state, as shown in the table below.

Table 2 · Hierarchy Icons

Icon	Description
.	SmartDesign component



Icon	Description
	SmartDesign component with HDL netlist not generated
	IP core was instantiated into SmartDesign but the HDL netlist has not been generated
	Core
	Error during core validation
	Updated core available for download
	HDL netlist

## Files Tab

The Files tab displays all the files associated with your project. Files are grouped by Components and User Files:

Component files include SmartDesign components, Designer blocks, CoreConsole and IP cores, and Synplify DSP components.

User Files include:

- Block Symbol Files
- Schematic Files
- HDL Source Files
- Stimulus Files
- Simulation Files
- Constraint Files
- Synthesis Files
- Designer Views (implementation files)

Right-clicking a file in the Files tab provides a menu of available options specific to the file type. You can also delete files from the project by selecting **Delete from Project** from the right-click menu. You can delete files from the project and the disk by selecting **Delete from Disk and Project** from the right-click menu.

You can [instantiate a component](#) by dragging the component to a SmartDesign window or by selecting **Instantiate in SmartDesign** from the right-click menu.

You can configure a component by double-clicking the component or by selecting **Open Component** from the right-click menu.

**Tip:** Tip: You can drag files in the Files tab to re-order them.

## Project Flow Window

The Project Flow window displays all available tools involved in the design process (as shown in the figure below).

This window shows you the current state of your design by activating and highlighting tools at appropriate times in the design process, while graying out tools that are not yet available. Green checks indicate successfully completed steps.

Click a tool to start it. Right-click a tool to access the right-click menu, which provides all the available processes you can start with the tool.

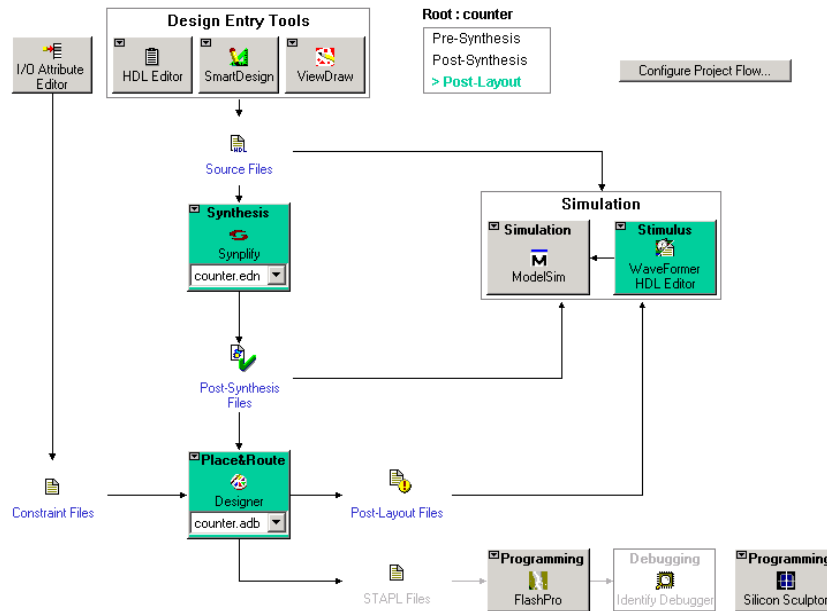

Figure 17 · Project Flow Window

**Note:** To create a Designer Block in the Libero IDE with an existing design, open your design and from the Project menu choose Settings and click the Flow tab. Note that your design must use a device family that supports Designer Blocks (IGLOO, ProASIC3, SmartFusion, Fusion, Axcelerator, and RTAX-S). After checking this option, the Programming and Debugging options are no longer visible in the Project Flow window.

## HDL Editor Window

The HDL Editor button opens the HDL editor in a new window. If you right-click the HDL Editor, it displays a list of files in the right-click menu. Files are listed according to the compile order; the top-level file always appears first.

The HDL Editor enables you to add and edit HDL code. It supports VHDL and Verilog with color, highlighting keywords for both HDL languages.

You must use the HDL Editor or [ViewDraw](#) to instantiate an imported CoreConsole project in your design.

**Note:** Note: To avoid conflicts between changes made in your HDL files, Actel recommends that you use one editor for all of your HDL edits.

# Catalog

The Catalog displays a list of available cores, HDL templates, busses, and Actel macros (see image below).

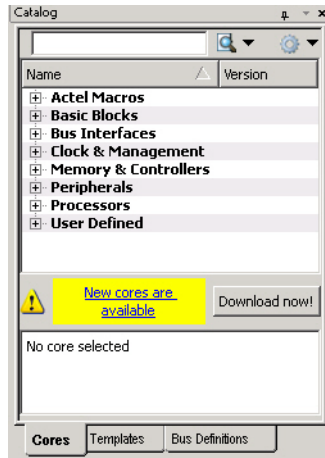

Figure 18 · Project Manager Catalog

From the Catalog, you can create a component from the list of available cores, add a CoreConsole processor or peripheral, add HDL source code to your text editor with the HDL templates, [add a bus interface to your SmartDesign component](#), or add an Actel macro to your SmartDesign component.

Double-click a core to configure it and add it to your design. Configured cores are added to your list of Components/Modules in the Design Explorer.

## Viewing Cores in the Catalog

The font indicates the status of the core:

- Plain text - In vault and available for use
- Asterisk after name (\*) - Newer version of the core (VLN) available for download
- *Italics* - Core is available for download but not in your vault
- ~~Strikethrough~~ - core is not valid for this version of Libero IDE

The colored icons indicate the license status. Blank means that the core is not license protected in any way. Colored icons mean that the core is license protected, with the following meanings:

**Green Key** - Fully licensed; supports the entire design flow.

**Yellow Key** - Has a limited or evaluation license only. Precompiled simulation libraries are provided, enabling the core to be instantiated and simulated within the Actel Libero Integrated Design Environment (IDE). Using the Evaluation version of the core it is possible to create and simulate the complete design in which the core is being included. The design is not synthesizable (RTL code is not provided). No license feature in the license.dat file is needed to run the core in evaluation mode. You can purchase a license to generate an obfuscated or RTL netlist.

**Yellow Key with Red Circle** - License is protected; you are not licensed to use this core.

Right-click any item in the Catalog and choose Show Details for a short summary of the core specifications. Choose Open Documentation for more information on the Core. Right-click and choose Configure Core to open the core generator.

Click the **Name** column heading to sort the cores alphabetically.

You can filter the cores according to the data in the Name and Description fields. Type the data into the filter field to view the cores that match the filter. You may find it helpful to set the [Catalog Display Options](#) to **List cores alphabetically** when using the filters to search for cores. By default the filter contains a beginning and ending `**`, so if you type 'controller' you get all cores with controller in the core name (case insensitive search) or in the core description. For example, to list all the Accumulator cores, in the filter field type:

```
accu
```

## Catalog Options

Click the Options button  to customize the [Catalog Display Options](#). Click the Catalog Options drop-down arrow to import a core, reload the Catalog, or [enter advanced download mode](#).

You may want to import a core from a file when:

- You do not have access to the internet and cannot download the core, or
- A core is not complete and has not been posted to the web (you have an evaluation core)

### See Also

[Project Manager - Cores Dialog Box \(Advanced Download Mode\)](#)

## Finding Files

Use the Find Window to search for files. Search options vary depending on your search type.

### To find a file:

1. Use CTRL + F to open the Find Window toolbar.



Figure 19 · Find Window (Search in Files)

2. Select your search type: Files, Modules in Project, Find Ports in SmartDesign, Find Nets in SmartDesign, Find Instances in SmartDesign, or Find Text in Text Editor.
3. Enter the name or part of name of the object you wish to find.
4. Set the Options for your search (see below for list); options vary depending on your search type.
5. Click **Find** (or **Next** if searching Text). The results appear in the Find In Files tab in the Log window (as shown in the figure below), on the Canvas if you search in SmartDesign, or in a new pane if you are searching Modules. Click the file name in the Log window to open the file.

```

Searching for 'entity'...
C:\Actelprj\count32\simulation\presynth\cntadd\_primary.vhd(3): entity cntadd is
1 occurrence have been found.
  
```

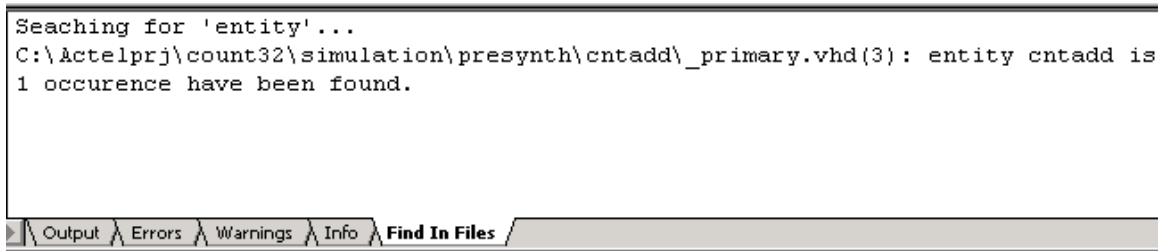

Figure 20 · Find In Files Tab in Project Manager Log Window

## Search in Files (Files button)

**Match case:** Select to search for case-sensitive occurrences of a word or phrase. This limits the search so it only locates text that matches the upper- and lowercase characters you enter.

**Match whole word:** Select to match the whole word only.

**In files/file types:** Select a file type to narrow your search.

**In folder:** Select a folder. Click the browse button to navigate to a different folder.

## Search Modules in Project (Modules button)

**Match case:** Select to search for case-sensitive occurrences of a word or phrase. This limits the search so it only locates text that matches the upper- and lowercase characters you enter.

**Match whole word:** Select to match the whole word only.

**Overwrite previous results:** Clears the contents of the Log window and writes the new results.

**Append to previous results:** Appends the new results to the contents of the log window. This option is useful if you are running several searches in succession and want to export the results.

**Existing Pane:** Displays your search results in an existing pane in the Log window.

**New Pane:** Displays your search results in a new pane in the Log window with a name you specify.

## Find Ports / Find Nets / Find Instances in SmartDesign

These searches are available only when you have a SmartDesign open. SmartDesign highlights your search results for ports / nets / instances on the Canvas.

**Match case:** Select to search for case-sensitive occurrences of a port / net / instance. This limits the search so it only locates the objects that match the upper- and lowercase characters you enter.

**Overwrite previous results:** Clears any currently selected ports / nets / instances in your design before selecting the matching ports / nets/ instances.

**Append to previous results:** Appends any new matches to the currently selected ports / nets/ instances in your design.

## Find Text in Text Editor (Text button)

**Previous:** Proceed to previous instance of found text.

**Next:** Proceed to next instance of found text.

**Mark All:** Marks all instances of the found text.

**Match case:** Select to search for case-sensitive occurrences of a word or phrase. This limits the search so it only locates text that matches the upper- and lowercase characters you enter.

**Match whole word:** Select to match the whole word only.

**Replace with:** Replaces the text you searched with the contents of the field. Click Replace All to replace all instances of the found text with the contents of the field.

## Log Window

### Colors and Symbols

For ProASIC and ProASIC<sup>PLUS</sup> families, the log window displays notes and warnings. For Antifuse families, the log window displays Error, warning, and informational messages. Messages are represented by symbols and color-coded. The default colors are:

Type	Color
Error	Red
Warning	Blue
Information	Black

The colors can be changed by using the [Preferences](#) dialog box.

### Output, Error, Warning, and Info Tabs

The Output tab displays all messages. Use the errors, warnings, or informational tabs to filter for just those messages. The views within the error, warnings, and info displays are reset when a new command is executed or a new design is opened. To see a complete history of your design session, click the output tab.

### Linked Messages

Error and warning messages that are dark blue and underlined are linked to online help to provide you with more details or helpful workarounds. Click them to open online help.

## Information Window

The Information Window lists new features or elements in the Project Manager with links to more information. You can resize or shrink the window if you want to use the space for other screen elements.

To show or hide the Information View window, from the **View** menu, choose **Toolbars > Information Window**.

## HDL Templates in the Project Manager

Use the templates in the Libero IDE Project Manager to create HDL.

To use the templates included with the Project Manager, open your VHDL or Verilog file in the Project Manager text editor. Right-click, and select Language Templates.

Place the cursor where you want to add the template, browse the list of VHDL and Verilog templates, and double-click the template to add it to your design.

The VHDL and Verilog templates are useful if you want to modify your netlist but are unfamiliar with the language. The templates facilitate the writing of HDL files by inserting predefined language constructs. You can also save your own template files to reuse in other designs (for example, if you wanted to add the same header in all your files).

### To create a user template:

- Import an HDL file as a template, or
- Save an open HDL file from the text editor as a template. To do so, right-click in the text editor and choose Export as Template.

## Project Manager Tcl Command Reference

A Tcl (Tool Command Language) file contains scripts for simple or complex tasks. You can run scripts from either the Windows or UNIX command line or store and run a series of Tcl commands in a \*.tcl batch file. You can also run scripts from [within the GUI](#) in Project Manager.

**Note:** Note: Tcl commands are case sensitive. However, their arguments are not.

The Libero IDE Project Manager supports the following Tcl scripting commands:

Command	Action
<a href="#">add_file_to_library</a>	Adds a file to a library in your project
<a href="#">add_library</a>	Adds a VHDL library to your project
<a href="#">add_modelsim_path</a>	Adds a ModelSim simulation library to your project
<a href="#">add_profile</a>	Adds a profile; sets the same values as the <a href="#">Add or Edit Profile dialog box</a>
<a href="#">associate_stimulus</a>	Associates a stimulus file in your project
<a href="#">change_link_source</a>	Changes the source of a linked file in your project
<a href="#">check_hdl</a>	Checks the HDL in the specified file

Command	Action
<a href="#">check_schematic</a>	Checks the schematic
<a href="#">close_project</a>	Closes the current project in Libero IDE
<a href="#">create_links</a>	Creates a link (or links) to a file/files in your project
<a href="#">create_symbol</a>	Creates a symbol in a module
<a href="#">delete_files</a>	Deletes files from your Libero IDE project
<a href="#">edit_profile</a>	Edits a profile; sets the same values as the <a href="#">Add or Edit Profile dialog box</a>
<a href="#">export_as_link</a>	Exports a file to another directory and links to the file
<a href="#">export_io_constraints_from_adb</a>	Exports the I/O constraints from your project ADB file to an output file
<a href="#">export_profiles</a>	Exports your tool profiles; performs the same action as the <a href="#">Export Profiles dialog box</a>
<a href="#">generate_ba_files</a>	Generates the back-annotate files for your design
<a href="#">generate_hdl_from_schematic</a>	Generates an HDL file from your schematic
<a href="#">generate_hdl_netlist</a>	Generates the HDL netlist for your design and runs the design rule check
<a href="#">import_files</a> (Libero IDE)	Imports files into your Libero IDE project
<a href="#">new_project</a>	Creates a new project in the Libero IDE
<a href="#">open_project</a>	Opens an existing Libero IDE project
<a href="#">organize_cdb</a> s	Organizes the CDB files in your project
<a href="#">organize_constraints</a>	Organizes the constraint files in your project
<a href="#">organize_sources</a>	Organizes the source files in your project
<a href="#">project_settings</a>	Modifies project flow settings for your Libero IDE project



Command	Action
<a href="#">remove_core</a>	Removes a core from your project
<a href="#">remove_library</a>	Removes a VHDL library from your project
<a href="#">remove_profile</a>	Deletes a tool profile
<a href="#">rename_library</a>	Renames a VHDL library in your project
<a href="#">rollback_constraints_from_adb</a>	Opens the ADB file, exports the PDC file, and then replaces it with the specified PDC file
<a href="#">run_designer</a>	Runs Designer with compile and layout options (if selected)
<a href="#">run_drc</a>	Runs the design rule check on your netlist and generates an HDL file
<a href="#">run_simulation</a>	Runs simulation on your project with your default simulation tool and creates a logfile
<a href="#">run_synthesis</a>	Runs synthesis on your project and creates a logfile
<a href="#">save_log</a>	Saves your Libero IDE log file
<a href="#">save_project</a>	Saves your project
<a href="#">save_project_as</a>	Saves your project with a different name
<a href="#">select_profile</a>	Selects a profile to use in your project
<a href="#">set_actel_lib_options</a>	Sets your simulation library to default, or to another library
<a href="#">set_device (Project Manager)</a>	Sets your device family, die, and package in the Project Manager
<a href="#">set_modelsim_options</a>	Sets your ModelSim simulation options
<a href="#">set_option</a>	Sets your synthesis options on a module
<a href="#">set_userlib_options</a>	Sets your user library options during simulation
<a href="#">set_root</a>	Sets the module you specify as the root

Command	Action
<a href="#">synplify</a>	Runs Synplify in batch mode and executes a Tcl script.
<a href="#">synplify_pro</a>	Runs Synplify Pro in batch mode and executes a Tcl script.
<a href="#">unlink</a>	Removes a link to a file in your project
<a href="#">use_file</a>	Specifies which file in your project to use
<a href="#">use_source_file</a>	Defines a module for your project

# Designing with Designer Block Components

Designer Blocks (also generically called "components") enable you to partition a design and optimize critical sections. You can reuse them later in new applications, ensuring consistent performance. Designing with blocks enables multiple designers to work independently on parts of a single design.

## Designer Block Advantages

- You can focus on the timing of critical blocks and ensure the timing across the blocks meets requirements before proceeding to the top-level flow.
- Changes in other blocks have no impact on your own block, you can re-use your block without re-calculating the timing.
- The block can be re-used in multiple designs
- Shorter verification time. You need to re-verify only the portion of the design that has changed.

## Designer Block Features

- You can create a Designer Block with or without I/Os.
- A Designer Block can be synthesized, simulated, and placed-and-routed the same way as a regular design.
- You can lock the place-and-route of the Designer Block to ensure performance does not change.
- Performance and place-and-route can be fixed absolutely; however these rules can be relaxed gradually, if necessary, to ensure that you can integrate the Designer Block into your <top> project.
- You can use all the features in Designer Blocks in [SmartDesign](#).

## Use Designer Blocks When

- The design is congested (uses 90% of the resources on a given die).
- You have difficulty meeting timing by doing the design in its entirety. Blocks enable you to compartmentalize the design and optimize sections before you optimize the entire design.
- You want to re-use some elements of your design.
- You want to use the identical elements multiple times in a single design.

You cannot use Designer Blocks with all families, they are family and die specific; if your Designer Block has I/Os it is also package specific.

## Supported families

IGLOO, ProASIC3, SmartFusion, Fusion, Axcelerator, and RTAX-S

## Designer Blocks and Synthesis

You must run the synthesis tool in No I/O mode when you create your component. The Designer Block is not a full design; Libero IDE sets this option for Synplify if you Enable Designer Block creation.

When you Publish a Designer Block, the Project Manager creates a timing shell that enables the synthesis tool to better synthesize the <top> project. The timing shell is named <blockname>\_syn.v(.vhd) if you are using Synplify or <blockname>\_pre.v(.vhd) if you are using Precision.

When you are working in your <top> project, the synthesis tool does not know how many globals you have in your Designer Block, or if there will be clock sharing. The synthesis tool promotes as many globals as it can (e.g., four globals for Axcelerator devices) and if you have globals in the Designer Block you will exceed the total number of globals allowed in your device.

In this case, you must limit the number of globals added by the synthesis tool so that the total number (Designer Block plus <top> project) does not exceed the number available on your device.

To add an internal global, you can use either the Synplify constraints editor (SCOPE) or an SDC file.

For example, to add a CLKINT after a CLK port, the command is:

```
define_attribute {n:CLK} syn_insert_buffer {CLKINT}
```

### See Also

[Creating a component in Designer](#)

[Creating a component in Libero IDE](#)

## Managing I/Os in a Designer Block Component

If you use I/Os in your Designer Block, use the following rules:

- If the I/O is placed in the block, placement and VCCI of the I/O cannot be changed in the <top> design.
- The register combining option cannot be changed in the <top> design.
- Attributes and Vref pins can be changed if the values are legal (the I/O will not be unplaced).

## Globals and Designer Block Components

You must manage your globals when creating a Designer Block to ensure that you have some available after you import the Block into your <top> project.

There is no limit to the number of globals you can use in a Designer Block.

### Global Sharing

You can share a global between the Designer Block and the <top> project. You must:

- Use an internal global in the Designer Block.
- Drive the global port in the <top> project with a global net.

Libero IDE removes the internal global and re-routes the entire net.

You can use other global macros in the Designer Block, but you cannot share them with the <top> project.

**Global Sharing with IGLOO, ProASIC3, SmartFusion and Fusion** - Use CLKINT in the Designer Block to share the global in the component with the <top> project.

**Global Sharing with Axcelerator and RTAX-S** - Use CLKINT and HCLKINT in the Designer Block to share the global in the component with <top> project. Also, you must drive HCLKINT within the Designer Block with an HCLK net in the <top> project; and drive CLKINT in the Designer Block with a RCLK in the <top> project.

See the list of [Physical Design Constraint](#) (PDC) files for more information on how to assign constraints.

## Local Clock

You can use local clocks in your component to save on globals, but you may need to do some floorplanning in your <top> project.

For example, if you are using an Axcelerator device: if you have one local clock in the Designer Block of type RCLK and four RCLK macros in the <top> project, the Prelayout checker fails. You must floorplan the project to restrict the load placement of one of the clocks in the <top> project.

### Limitations

When you create your block, you cannot assign a port-connected net to a local clock.

The routing for local clocks from the blocks cannot always be preserved.

For Axcelerator all local clocks will be rerouted in the <top> design.

For all other families, local clocks are rerouted only if they are used in more than one block. The local clock constraint is preserved and the only difference in the routing is from the driver to the entry point of the clock network (when it gets to the clock network you end up with the same routing since the macros are locked in the same location).

## Designer Block Compile Report

If you instantiate Designer Blocks in your design, the Compile report includes a description of the blocks you used.

The report appears in the Designer Log window after Compile is complete.

The report lists the name of the module, the name of the instance, the number of macros and nets used in the blocks, and information on how conflicts between blocks were resolved by the Compile options or PDC commands (if any).

For example:

```
Block Information Report :
=====
Conflict resolution from Compile options :
=====
    Placement : Resolve conflict/Keep and Lock non conflicting placement
    Routing   : Resolve conflict/Keep and Lock non conflicting routing
```

```

-----
Block Name : core1
Instance Name : core1_inst
| Locked | Total
-----
Instances | 4 | 4 (100.00%)
Nets | 3 | 3 (100.00%)
-----

Block Name : core1
Instance Name : core11_inst
PDC Constraints :
=====
Move : move_block -inst_name {core11_inst} -left 10 -up 0 -non_logic UNPLACE
| Locked | Total
-----
Instances | 4 | 4 (100.00%)
Nets | 0 | 3 (0.00%)

```

## Designer Block Component Limitations

If you instantiate the same Designer Block many times in the <top> design, only the first instance retains the place-and-route information (if it has any); the others do not. Only the netlist is preserved.

To preserve the relative placement and routing of other blocks you must move the blocks using a PDC command. This PDC file must be imported as a source file along with the netlist(s) and CDB files. If possible, routing is preserved when you move the blocks with a PDC command.

See the [move\\_block](#) PDC command for more information.

**Note:** Note: Axcelerator and RTAX-S routing is not preserved when you move a block.

---

# **Creating a Designer Block Component in Libero IDE**

## Creating a Designer Block Component in Libero IDE

You must create two Libero IDE projects in order to instantiate your Designer Block in Libero IDE: one to create and publish your Designer Block, and another in which to instantiate your Designer Block. This section describes how to create your Designer Block.

See [Instantiating a Designer Block in Libero IDE](#) for more information.

The general design flow for creating a Designer Block in Libero IDE is shown in the figure below.

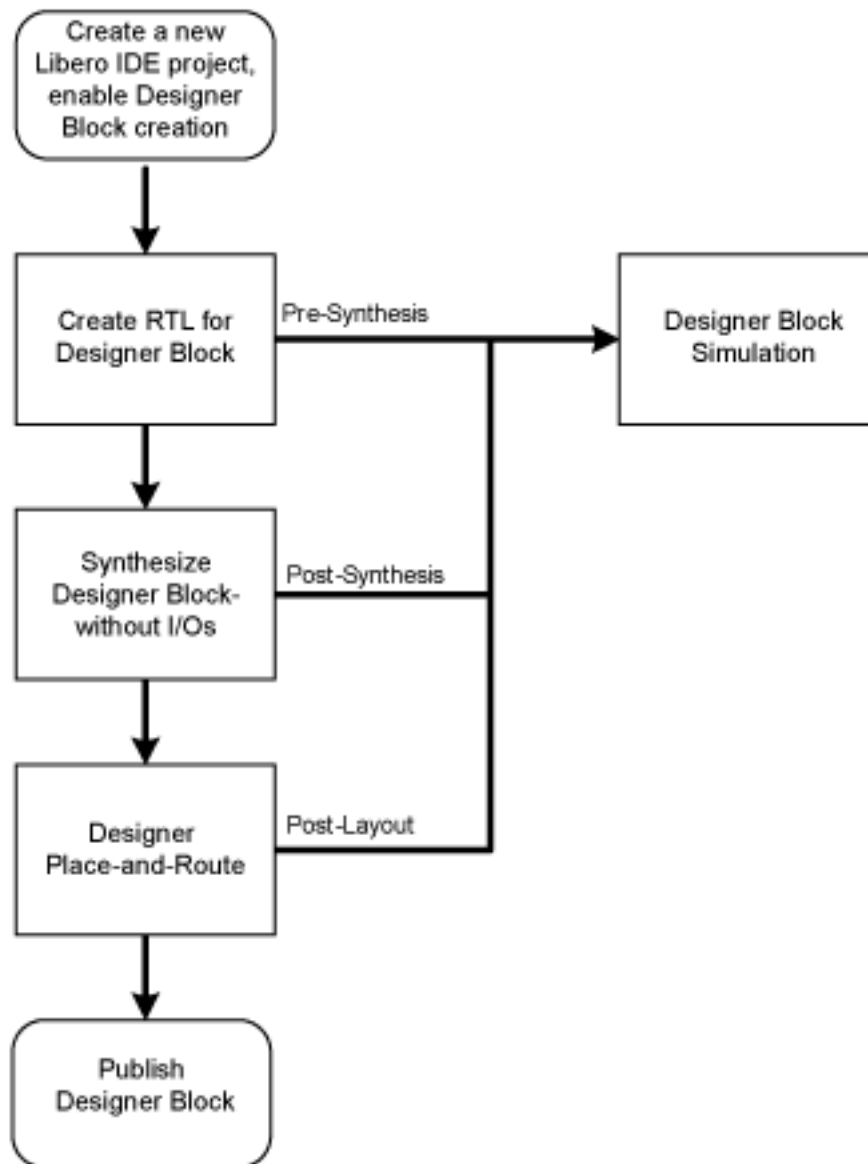

Figure 21 · Create a Designer Block Flow in Libero IDE



**To create a Designer Block in Libero IDE with a new design:**

1. Start a [new project](#). You must select a family that supports Block designs (IGLOO, ProASIC3, SmartFusion, Fusion, Axcelerator, and RTAX-S). After your project opens, from the **Project** menu, choose **Settings > Flow**, and click the **Enable Designer Block creation** checkbox.
2. Create a design in Libero IDE (standard [design flow](#) - create RTL, synthesize, run place-and-route and generate the block using Designer).

To create a Designer Block in the Libero IDE with an existing design, open your design and from the **Project** menu, choose **Setting > Flow**, and click the **Enable Designer Block creation** checkbox. Note that your design must use a device family that supports Designer Blocks (IGLOO, ProASIC3, SmartFusion, Fusion, Axcelerator, and RTAX-S).

## Instantiating a Designer Block in Libero IDE

You must have two projects in order to instantiate your Designer Block in Libero IDE: one to create and publish your Designer Blocks, and another in which to instantiate your Designer Block. This topic and the flow shown in the figure below describe how to instantiate your Designer Block in the Libero IDE.

See [Creating a Designer Block in Libero IDE](#) for information on how to create a Designer Block. You can also import your Designer Blocks into [SmartDesign](#).

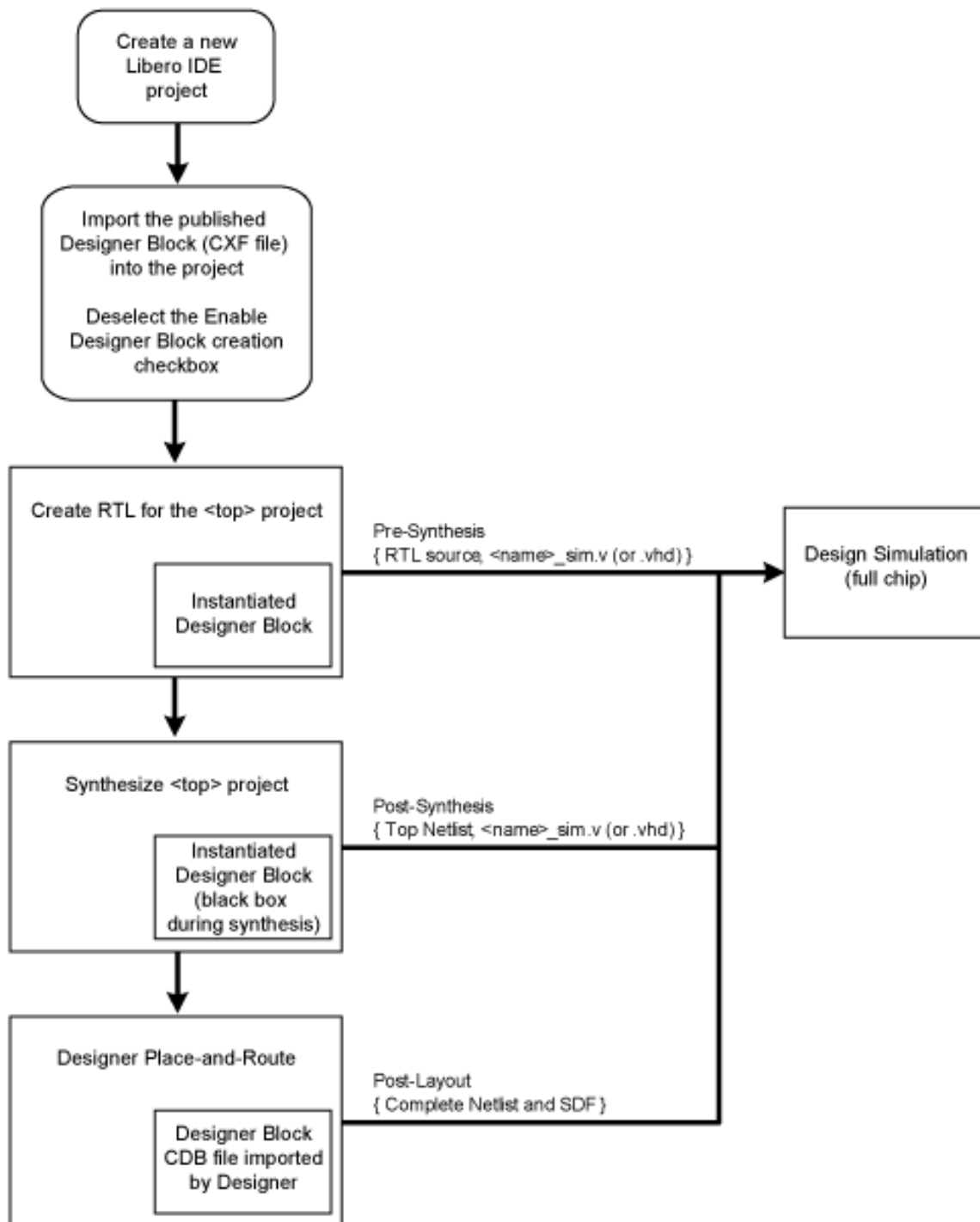

Figure 22 · Libero IDE Designer Block Instantiation Flow

To instantiate (import) a Designer Block in Libero IDE, [import](#) your design netlist and CXF file(s). The CXF file imports all the files you need for your Designer Block. After you import your files, the [design flow](#) is the same as

regular Libero IDE designs. There is no limit to the number of CXF files you can import, but you cannot import the same Designer Block more than once, and the family and device for your imported block must match your project.

After you import the CXF file, the Project Manager displays the imported files in the Design Hierarchy tab.

The Designer Block(s) you instantiate must have the same family and die (and package, if it contains I/Os) as your current <top> project. If the family, die, and package do not match, Libero IDE asks if you want to change the current setting to match the one from the Designer Block.

The Project Manager passes all the Designer Block files to Designer automatically.

**Note:** Note

- Disable Designer Block creation when you import a component into your <top> project. If you are using a Designer Block component to create another Designer Block, leave it enabled.
- If you already have an HDL component with the same name as the one you imported, the new Designer Block component is not be used by default. You must and right-click the Designer Block component in the Project Manager and choose **Use this file** to make it use your Designer Block.

# Creating a Designer Block Component in Designer

To create a Designer Block component in Designer, start a new design, and **Enable Designer Block creation** in the Setup Design dialog box. You must select a family that supports Designer Blocks.

You cannot create a Designer Block after you start a new design; you must create a new design and Enable Designer Block creation at the start.

To create a new design and Enable Designer Block creation using a script, use the command string:

```
new_design -name "test" -family "ProASIC3" -path {.} -block "ON"
```

After you create your new Designer Block, proceed as usual.

1. Import your [source](#) and [auxiliary](#) file(s)
2. [Compile](#) your design
3. Run [Layout](#) to place-and-route your design
4. [Back-Annotate](#) your design (if necessary)
5. Publish your Designer Block

## Designer Block Component PDC Commands

### Creating a Block

The Designer-Block specific PDC command [set\\_port\\_block](#) enables you to remove an I/O connected to a component port and add a buffer before or after a component port to limit the fanout of the port net. The command applies only to the selected port.

The tribuf and bibuf I/Os cannot be removed.

Adding a buffer enables more precise Designer Block timing, since the nets driving ports are not preserved when the Designer Block is generated/published.

### Instantiating a Block

The following PDC commands manage conflict resolution between blocks. Each command is specific to an instance of a block.

- [move\\_block](#) - Moves Designer Blocks from their original locked placement by preserving the relative placement between the instances. You can move them left, right, up or down.

- [set\\_block\\_options](#) - Overrides the compile option for placement or routing conflicts for either a specific block or an instance of a block.

## Floorplanning a Designer Block

Actel recommends that you [floorplan](#) your Designer Block component (in MVN or with PDC commands) to ensure that your Designer Block is placed in a [specific region](#). If you do not restrict your Designer Block placement, it may be placed anywhere on your die; see the [define\\_region](#) PDC command.

It is also important to consider the placement of all interface macros in the boundaries of these regions. This facilitates the interconnection of the Designer Block to the top-level design. If the Designer Block is highly optimized (densely packed) there may be no routing channels available to connect to any internal Designer Block interface macro. Placing all interfaces at Designer Block boundaries helps you eliminate routability issues, routing congestion, and failure.

Designer-Block specific features in [MVN](#) are:

- Block Ports tab - Lists all the ports in a Designer Block even if they are not connected to I/Os.
- Interface Instances in Designer Block creation (in the [Active Lists](#)) - Lists all macros connected to ports. These macros must be placed on the boundary of your Designer Block region, since they will be connected to the <top> design.
- Designer Block content available when you instantiate a Designer Block in the <top> design (in Active Lists) - Lists all macros in the Designer Block.
- A block tab that lists all the blocks in your design.
- Search support that enables you to find a specific block in your design.
- Show the routing of locked nets from the Designer Blocks immediately after compile is complete; no need to wait until layout is finished since the routing is locked and will not be changed.

## Generate a Designer Block Component in Designer

When you finish Compile and Layout, click **Generate Block** to create your Designer Block files.

When you publish your Designer Block, Designer creates a netlist file (\*.v; \*.vhd), info file for Libero IDE (\*.cxf), Designer Block file (\*.cdb), and report files.

Libero IDE uses the CXF file to manage and audit the Designer Block in your project. The CDB file contains all your design information for the Designer Block.

You can edit your Designer Block later; just open the design, make your changes, and re-create.

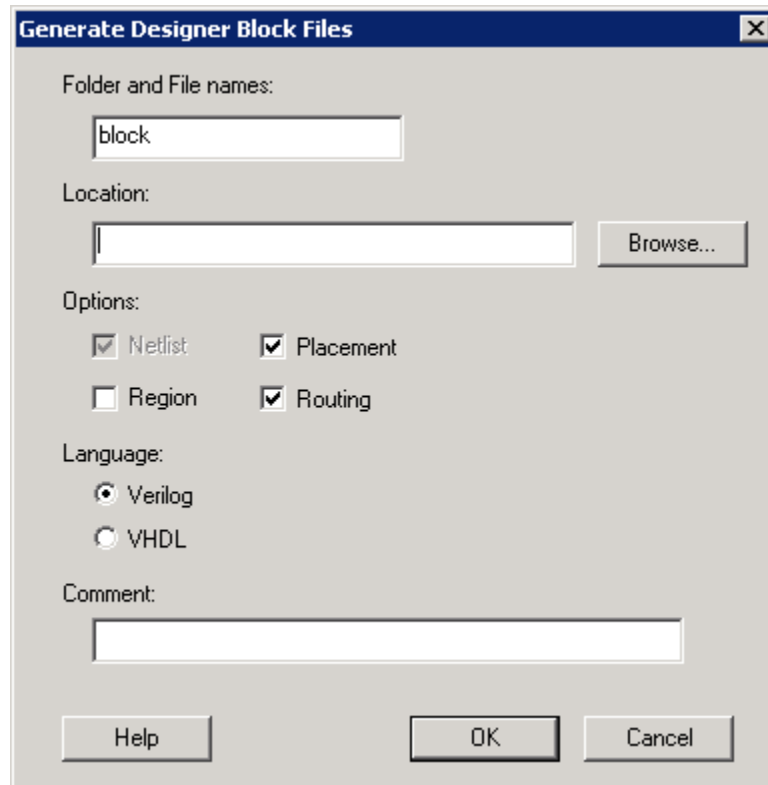

Figure 23 · Generate Designer Block Files Dialog Box

**Designer Block name** - Specifies the name of all your exported files. The exported Designer Block files in this example are named block\_test.cxf, block\_test.cdb, and block\_test\_syn.v and block\_test\_sim.v (block\_test\_syn.vhd and block\_test\_sim.vhd for VHDL).

**Location** - Specifies the location of your exported Designer Block files. Click the Browse button to navigate if you do not know the full pathname.

#### Options

Generates (exports) your Netlist, Placement, Routing, and Region information. The options available depend on whether you ran place-and-route, placer only, or compile.

**Netlist** - Always published by default. You cannot deselect this option.

**Placement** - Available only if you have already run place. This option fixes the internal block elements so they will not move after you import them in your <top> design. Select this option if you are satisfied with the current placement of your block.

**Routing** - Available if you run place-and-route and opt to preserve Placement. This option fixes your place-and-route and ensures that your block timing does not change in your <top> design.

**Region** - Exports the regions (if any) you used when you created your block. Useful if you use an exclusive region on top of your Designer Block. You can delete these regions in your <top> design.

The only recommended use case for this option is when you add an exclusive region on top of your block. Actel recommends you leave this option unselected for all other cases.

**Language** - Specify your export language.

**Comment** - Add a comment to your exported files (visible in Designer in the Block report available in **Tools > Reports > Block**).

### **See Also**

[export Designer Block Tcl command](#)

# Instantiating a Designer Block Component in Designer

To instantiate (import) a Designer Blocks into a design:

1. Open your design.
2. Deselect **Enable Designer Block creation** in the Setup Design dialog box.
3. Import your netlist (\*.v, \*.vhd, or EDIF file) and CDB files from your component. The CDB file is created when you publish your component.

If you have no I/Os, the imported Designer Block must have the same family and die as your current design.

If you have I/Os in your Designer Blocks, the imported block must have the same family, die, and package as your current design.

**Note:** Note: IGLOO, ProASIC3, SmartFusion and Fusion families ONLY - Blocks that contain only COREs and RAM/FIFOs can be instantiated in a design belonging to any family and die.

## Exporting an Instantiated Designer Block Component

You can export component CDB files after you instantiate (import) them into your design.

You may wish to reuse the files in another design, or rerun the flow again.

To export a CDB file, from the **File** menu, choose **Export > Netlist Files** and for the Save as type, choose **Actel CDB files (\*.cdb)**. The exported CDB file is identical to the original imported CDB file.

If you export a Designer Block that contains multiple CDB files, the exported files are identical to the original imported CDB files.

If your design contains many CDB files, the block name is added as a suffix to the specified filename; the names of all exported files are listed in the Log window. For example:

```
Wrote to files:  
E:\block\dblock.cdb  
E:\block\dblock_core2.cdb
```

## Conflict Resolution in Designer Blocks

If you instantiate more than one block in your design, you may have a conflict between the blocks. Designer manages conflicts between blocks according to the following priority:

1. CDB file order (as specified in the [CDB File Organization](#) dialog box in the Project Manager). You can change this order in Designer; to do so, from the File menu, choose Import Source Files.



2. [Compile options](#) set to resolve place-and-route conflicts between blocks (see below for a full explanation of the Block Instantiation compile options)
3. PDC options ([set block options](#) and [move block](#))

You can review the results of the conflict resolution in the [Compile report](#) and in the [Block tab](#) in MVN.

## Block Instantiation Compile Options

If there multiple blocks instantiated in your design, Designer uses the Compile options to resolve the conflicts.

### Placement

Value	Description
ERROR	Compile errors out if any instance from a designer block is unplaced. This is the default option.
RESOLVE	If some instances get unplaced for any reason, the remaining non-conflicting elements are unplaced. In other words, if there are any conflicts, nothing from the block is kept.
KEEP	If some instances get unplaced for any reason, the non-conflicting elements remaining are preserved but not locked (you can move them).
LOCK	If some instances get unplaced for any reason, the remaining non-conflicting elements are preserved and locked.

### Routing

Value	Description
ERROR	Compile errors out if any preserved net routing in a designer block is deleted.
RESOLVE	If a nets' routing is removed for any reason, the routing for non-conflicting nets is also removed. In other words, if there are any conflicts, no routing from the block is kept
KEEP	If a nets routing is removed for any reason, the routing for the non-conflicting nets is preserved but not locked (so that they can be rerouted).
LOCK	If the routing is removed for any reason, the remaining non-conflicting nets are

Value	Description
	preserved and locked; they cannot be rerouted. This is the default option.

## Designer Block Report

The Designer Block report is available in **Tools > Reports > Block**. It includes a compile, global, datasheet, and interface report and Designer Block-related information.

The block reports are available in the Project Manager Files tab after you generate your block and instantiate it in your project. Double-click the report to view the contents.

In the Project Manager there is a header\_report.log that contains only the options used to generate the block. This information is available in each report you generate from the Designer > Tools menu.

### Compile

Use it to evaluate resources and manage the globals in the other blocks and the <top> design (if necessary).

### Datasheet

Lists block timing and I/O placement information. If the block is preserved during instantiation (both placement and routing) you can expect to get the same results as are shown in this report.

### Global

Lists global usage in the block. Useful if you want to evaluate the globals used by the block / manage globals in the overall design.

### Interface

The Interface section lists:

- Connection information for interface macros connected to the block ports
- Block placement information, including each port and its fanout, type (pad, clock, global, etc.), direction, and name
- Information on legal move locations, useful if you are instantiating multiple blocks in one design

---

# SmartDesign

## About SmartDesign

SmartDesign is a revolutionary innovation for creating and managing block-based designs. SmartDesign enables you to take configured cores, IP cores, and macros from a Project Manager [Catalog](#), and user-created HDL source files, and instantiate them into your design. SmartDesign displays your design in multiple views enabling you to access and manipulate your design quickly and efficiently.

You can drag configured cores onto a [Canvas](#) where they are viewed as blocks in a functional block diagram. From the Canvas you can:

- Make connections between your blocks
- View individual connection details
- Show or hide individual nets
- Set or clear attributes (such as Invert, Tie Low, Tie High, or Tie Open)
- Add slices
- Move, duplicate, or delete blocks
- Add notations such as labels, shapes, lines, or arrows to document your design
- Auto-stitching interfaces and other connections (such as AMBA)
- [Memory Map / Datasheet](#) - The datasheet reports the memory map of the different subsystems of your design, where a subsystem is any independent bus structure with a Master and Slave peripheral attached.

SmartDesign supports all Actel product families.

## SmartDesign Design Flow

SmartDesign enables you to stitch together design blocks of different types (HDL, IP, etc ) and generate a top-level design. The Files tab lists your SmartDesign files in alphabetical order.

You can build your design using SmartDesign with the following steps:

**Step One – Instantiating components:** In this step you will [add one or more building blocks](#), HDL modules, components, and schematic modules from the project manager to your design. The components can be Designer blocks, cores generated from the core Catalog, and IP cores.

**Step Two – Connecting bus interfaces:** In this step, you can [add connectivity via standard bus interfaces](#) to your design. This step is optional and can be skipped if you prefer manual connections. Components generated from the Catalog in Project Manager may include pre-defined interfaces that allow for [automatic connectivity](#) and design rule checking when used in a design.

**Step Three – Connecting instances:** The [Canvas](#) allows you to create manual connections between ports of the instances in your design. Unused ports can be [tied off](#) to GND or VCC (disabled); input buses can be [tied to a constant](#), and you can leave an output open by [marking it as unused](#).

**Step Four – Validating the SmartDesign component:** Verify the connectivity of your design using the Design Rules Check. This feature opens a special grid where design errors and warnings are organized by type and message. You can fix the errors and warnings directly in the grid. You must run the Design Rules Check again after you make your connections to check for new errors and warnings.

**Step Five – Generating the SmartDesign component:** In this step, you generate a top-level (Top) component and its corresponding HDL file. This component can be used by downstream processes, such as synthesis and simulation, or you can add your SmartDesign HDL into another SmartDesign.

You can save your SmartDesign at any time.

## Using Existing Projects with SmartDesign

You can use existing Libero® Integrated Design Environment (IDE) projects with available building blocks in the project to assemble a new SmartDesign design component. You do not have to migrate existing top-level designs to SmartDesign and there is no automatic conversion of the existing design blocks to the SmartDesign format.

**Note:** Note: Cores used in previous versions of software will work in SmartDesign, but they will NOT include standard bus interfaces if they are available. Bus interfaces (BIFs) can be recovered by regenerating the core in the latest software.

**Note:** Examples of cores with standard BIFs: ASB, Flash Memory System Builder, VRPSM, AMBA DirectCore(s), and similar.

## SmartDesign Frequently Asked Questions

The collection of SmartDesign Frequently Asked Questions are useful for anyone that is new to SmartDesign. All the information listed below is explained in detail in other sections of the help, but the information is summarized here for easy reference. Click any question to go to the corresponding explanation.

## General Questions

1. [What is SmartDesign?](#)
2. [How do I create my first SmartDesign?](#)

## Instantiating your SmartDesign

1. [Where is the list of cores that I can instantiate into my SmartDesign?](#)
2. [How do I instantiate cores into my SmartDesign?](#)
3. [I have a block that I wrote in VHDL \(or Verilog\), can I use that in my SmartDesign?](#)

## Working in SmartDesign

1. [How do I make connections?](#)
2. [Auto Connect didn't connect everything for me; how do I make manual connections?](#)
3. [How do I connect a pin to the top level?](#)
4. [Oops, I just made a connection mistake. How do I disconnect two pins?](#)
5. [I need to apply some simple 'glue' logic between my cores. How do I do that?](#)
6. [My logic is a bit more complex than inversion and tie offs - what else can I do?](#)
7. [How do I create a new top level port for my design?](#)
8. [How do I rename one of my instances?](#)
9. [How do I rename my top level port?](#)
10. [How do I rename my group pins?](#)
11. [I need to reconfigure one of my Cores, can I just double click the instance?](#)
12. [I want more Canvas space to work with!](#)

## Working with Processor-Based Designs in SmartDesign

1. [How do I connect my peripherals to the bus?](#)
2. [How do I view the Memory Map of my design?](#)
3. [How do I simulate my processor design?](#)
4. [I have my own HDL block that I want to connect as a peripheral on the AMBA bus. How can I do that?](#)

## Making your Design Look Nice

1. [Can the tool automatically place my instances on the Canvas to make it look nice?](#)
2. [My design has a lot of connections, and the nets are making my design hard to read. What do I do?](#)
3. [My instance has too many pins on it, how can I minimize that?](#)
4. [Oops, I missed one pin that needs to be part of that group? How do I add a pin after I already have the group?](#)
5. [I have a pin that I don't want inside the group, how do I remove it?](#)
6. [How can I better see my design on the Canvas?](#)



## Generating your Design

1. [Ok, I'm done connecting my design, how do I 'finish' it so that I can proceed to synthesis?](#)
2. [I get a message saying it's unable to generate my SmartDesign due to errors, what do I do? What is the Design Rules Check?](#)
3. [Is there an easy way for me to tie off multiple pins at once?](#)

## General Questions

### What is SmartDesign?

[SmartDesign](#) is a design entry tool. It's the first tool in the industry that can be used for designing System on a Chip designs, custom FPGA designs or a mixture of both types in the same design. A SmartDesign can be the entire FPGA design, part of a larger SmartDesign, or a user created IP that can be stored and reused multiple times. It's a simple, intuitive tool with powerful features that enables you to work at the abstraction level at which you are most comfortable.

It can connect blocks together from a variety of sources, verify your design for errors, manage your memory map, and generate all the necessary files to allow you to simulate, synthesize, and compile your design.

### How do I create my first SmartDesign?

From the Project Manager Project Flow window, in the Design Entry Tools section, click the SmartDesign icon:



## Instantiating Your SmartDesign

### Where is the list of Cores that I can instantiate into my SmartDesign?

The list of available cores is displayed in the [Project Manager Catalog](#). This catalog contains all DirectCore IP, Design Block cores, and Actel macros.

### How do I instantiate cores into my SmartDesign?

Drag and drop the core from the [Catalog](#) onto your SmartDesign [Canvas](#). The configurator for that core opens automatically. Choose your configurations, click OK, and an instance of your core appears on the SmartDesign Canvas.

### I have a block that I wrote in VHDL ( or Verilog ), can I use that in my SmartDesign?

Yes! Import your HDL file into the Project Manager (File > Import Files). After you do this, your HDL module will appear in the Project Manager [Hierarchy](#). Then, drag-and-drop it from the Hierarchy onto your SmartDesign Canvas.

## Working in SmartDesign

### How do I make connections?

Let SmartDesign do it for you. Right-click the [Canvas](#) and choose **Auto Connect**.

### Auto Connect didn't connect everything for me, how do I make manual connections?

1. Select the pins you want connected by using the mouse and the CTRL key.
2. Right-click one of the selected pins and choose **Connect**.
3. For bus interface pins you can do the same thing, OR: Right click a bus interface pin, choose **Find Compatible Bus Interfaces**. A dialog box will display a list of the compatible bus interfaces in the design that you can connect to. Choose the bus interface you want to connect to from the list and click OK.

### How do I connect a pin to the top level?

Right-click the pin and choose **Promote to Top Level**. You can even do this for multiple pins at a time, just select all the pins you want to promote, right-click one of the pins and choose **Promote to Top Level**. All your selected pins will be promoted to the top level.

### Oops, I just made a connection mistake. How do I disconnect two pins?

Use CTRL+Z to undo your last action. If you want to undo your 'undo', hit redo (CTRL+Y).

To disconnect pins you can:

- Right-click the pin you want to disconnect and choose **Disconnect**
- Select the net and hit the delete key

### I need to apply some simple 'glue' logic between my cores. How do I do that?

For basic inversion of pins, you can right-click a pin and choose **Invert**. An inverter will be placed at this pin when the design is generated. You can also right-click a pin and choose Tie Low or Tie High if you want to connect the pin to either GND or VCC.

To tie an input bus to a constant, right-click the bus and choose **Tie to Constant**. To mark an output pin as unused, right-click the pin and choose **Mark as Unused**.

To clear these, just right-click on the pin again and choose **Clear Attribute**.

#### **My logic is a bit more complex than inversion and tie offs - what else can I do?**

You have full access to the Actel library macros, including AND, OR, and XOR logic functions. These are located in the [Project Manager Catalog](#), listed under Actel Macros. Drag the logic function you want onto your SmartDesign Canvas.

#### **How do I create a new top level port for my design?**

You can right-click either of the top level blocks (gray blocks on the left and right of the Canvas space). Right-click the block on the far left of your Canvas (this represents the top level of your design) and choose **Add Port**.

#### **How do I rename one of my instances?**

Double-click the instance name on the Canvas and it will become editable. The instance name is located directly above the instance on the Canvas.

#### **How do I rename my top level port?**

Right-click the port you want to rename and choose **Modify Port**.

#### **How do I rename my group pins?**

Double-click the group pin name in the instance and it will become editable.

#### **I need to reconfigure one of my Cores, can I just double click the instance?**

Yes.

#### **I want more Canvas space to work with!**

Maximize your workspace (CTRL-W), and your Canvas will maximize within the Project Manager. Hit CTRL-W again if you need to see your Hierarchy or Catalog.

## Working with Processor-Based Designs in SmartDesign

### How do I connect my peripherals to the bus?

Make sure you have the proper bus core that is compatible with your peripheral instantiated in the design. Click **Auto Connect** and SmartDesign will automatically form the connections.

### But I need my peripheral at a specific address or slot.

Right-click the Canvas and choose **Modify Memory Map** to invoke the Modify Memory Map dialog that enables you to set a peripheral to a specific address on the bus.

The bus core will show the slot numbers on the bus interface pins. These slot numbers correspond to a memory address on the bus.

Verify that your peripheral is mapped to the right bus address by viewing your design's Memory Map.

### How do I view the Memory Map of my design?

In the Project Manager menu bar, choose **SmartDesign > Show Memory Map/Data Sheet**. This creates a datasheet of your design, including the pin out, cores used, and memory map.

The memory map section will also show the memory details of each peripheral, including any memory mapped registers.

### How do I simulate my processor design?

SmartDesign automatically generates the necessary Bus Functional Model (BFM) scripts required to simulate your processor based design. A top level testbench for your SmartDesign is generated automatically as well.

Create your processor design, generate it, and you will be able to simulate it in *ModelSim*.

### I have my own HDL block that I want to connect as a peripheral on the AMBA bus. How can I do that?

If your block has all the necessary signals to interface with the AMBA bus protocol ( ex: address, data, control signals) then:

1. In the [Project Manager Catalog](#) (inside the Bus Definitions tab), find the AHB or APB slave interface.
2. Drag this bus definition onto your instance on the Canvas. A dialog box opens, asking you to map the signals on your instance to the required bus definition signals. Complete this mapping and click OK.

Now your instance has a proper AMBA bus interface on it. You can manually connect it to the bus or let Auto Connect find a compatible connection.

## Making your Design Look Nice

**Can the tool automatically place my instances on the Canvas to make it look nice?**

Yes. Right-click the Canvas white space and choose **Auto Arrange Instances**.

**My design has a lot of connections, and the nets are making my design hard to read. What do I do?**

You can disable the display of the nets in the menu bar (Canvas > Nets). This automatically hides all the nets in your design.

You can still see how pins are connected by selecting a connected pin, the net will automatically be visible again.

You can also selectively show certain nets, so that they are always displayed, just right click on a connected pin and choose **Show Net**.

**My instance has too many pins on it; how can I minimize that?**

[Try grouping functional or unused pins together](#). For example, on the CoreInterrupt there are 8 FIQSource\* and 32 IRQSource\* pins, group these together since they are similar in functionality.

To group pins: Select all the pins you want to group, then right-click one of the pins and choose **Add pins to group**.

If a pin is in a group, you are still able to use it and form connections with it. Expand the group to gain access to the pin.

**Oops, I missed one pin that needs to be part of that group? How do I add a pin after I already have the group?**

Select the pin you want to add and the group pin, right-click and choose **Add pins to <name> group**.

**I have a pin that I don't want inside the group, how do I remove it?**

Right-click the pin and choose **Ungroup selected pins**.

**How can I better see my design on the Canvas?**

There are zoom icons in the toolbar:



From left to right, they are: Zoom in, Zoom out, Zoom to fit, and Zoom range. You can also maximize your workspace with CTRL-W.

## Generating your Design

**Ok, I'm done connecting my design, how do I 'finish' it so that I can proceed to synthesis?**

In the Project Manager toolbar, click the Generate Design icon  or right-click the Canvas and choose **Generate Design**.

**I get a message saying it's unable to generate my SmartDesign due to errors, what do I do? What is the Design Rules Check?**

In the Project Manager toolbar, click the Design Rules Check icon:



The Design Rules Check will give you a list of all the errors and warnings in your design, including unconnected input pins, required pin connections, configuration incompatibilities between cores, etc.

Errors are shown with a small red stop sign and must be corrected before you can generate; warnings may be ignored.

#### **What does this error mean? How do I fix it?**

Review the [Design Rules Check topic](#) for an explanation of errors in the Design Rules Check and steps to resolve them.

#### **Is there an easy way for me to tie off multiple pins at once?**

Yes, if you are in the Design Rules Check grid, you can select multiple pins by highlighting the rows that they are in. Multi-selecting works just like your typical spreadsheet editor.

Once all the pins have been selected, right-click one of the pin names and choose **Tie Low** or **Tie High**. Make sure you only have input pins selected otherwise the menu item won't be enabled.

# Getting Started with SmartDesign

## Creating a New SmartDesign Component

1. From the **File** menu, choose **New** or press the **SmartDesign** button in the Project Manager Project Flow window. The **New** dialog box opens (see figure below - file types vary depending on your project settings).

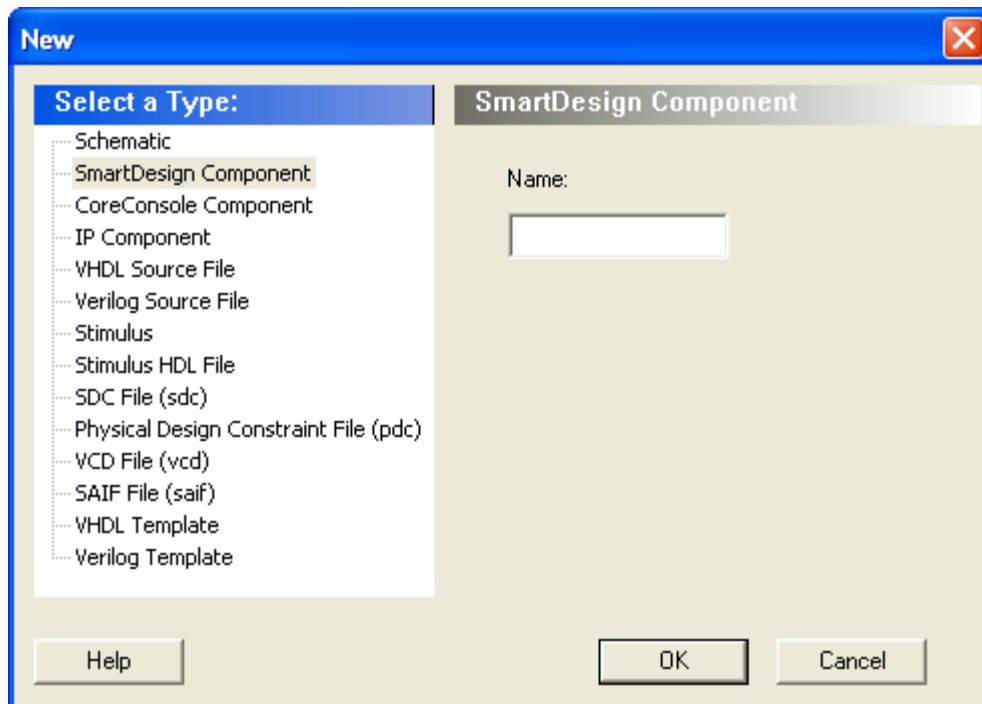

Figure 24 · New Dialog Box

2. Select **SmartDesign Component**, enter a component name and click **OK**. The component appears in the [Hierarchy](#) tab of the Design Explorer. Also, the main window displays the design [Canvas](#).

Note: Note: The component name must be unique in your project.

## Opening an Existing SmartDesign Component

**To open an existing component do one of the following:**

- In the Design Explorer, click the **Hierarchy** tab and double-click the component you want to open.
- In the Design Explorer, from the Files tab, expand the Components list and double-click the component you want to open.

The main window displays the SmartDesign [Canvas](#) for the SmartDesign component.



## Saving/Closing a SmartDesign Component

To save the current SmartDesign design component, from the File menu, choose **Save** <component\_name>. Saving a SmartDesign component only saves the current state of the design; to generate the HDL for the design refer to [Generating a SmartDesign component](#).

To close the current SmartDesign component without saving, from the **File** menu, choose **Close**. Select **NO** when prompted to save.

To save the active SmartDesign component with a different name use Save As. From the **File** menu choose **Save SD\_<filename> As**. Enter a new name for your component and click **OK**.

You can also close a SmartDesign component by right-clicking the name of the SmartDesign tab in the work area window and choosing **Close**, as in the figure below.

Figure 25 · Close a SmartDesign

## Importing a SmartDesign Component

Importing an existing SmartDesign component into a SmartDesign project will not automatically import the sub-components of that imported SmartDesign component.

You must import each sub-component separately.

After importing the sub-components, you must open the SmartDesign component and [replace](#) each sub-component so that it references the correct component in your project. .

## Deleting a SmartDesign Component from the Libero IDE Project

**To delete a SmartDesign component from the project:**

1. In the **Design Explorer**, click the **Hierarchy** tab.
2. Select the SmartDesign component that you want to delete. Right-click the component name and select **Delete from Project** or **Delete from Disk and Project**, or click the **Delete** key to delete from project.

## Memory Maps / Data Sheet

If your design contains standard Bus Instances such as the DirectCore AMBA bus cores, CoreAPB or CoreAHB, then you can view the Memory Map Configuration of your design. To do so, from the SmartDesign menu, choose **Show Memory Map / Data Sheet**.

The design's memory map is determined by the connections made to the bus component. A bus component is divided into multiple slots for slave peripherals or instances to plug into. Each slot represents a different address location and range to the Master of the bus component.

The datasheet reports the memory map of the different subsystems of your design, where a subsystem is any independent bus structure with a Master and Slave peripheral attached.

Connecting peripherals to busses can be accomplished using the normal SmartDesign connectivity options:

- **Auto-Connect** - the system finds compatible bus interfaces and connects them together
- [The Modify Memory Map dialog box](#)
- [Canvas](#) - Make connections between your blocks.
- Finding compatible [bus interfaces](#)

Your application and design requirements dictate which address location (or slots) is most suitable for your bus peripherals. For example, the memory controller should be connected to Slot0 of the CoreAHB bus because on Reset, the processor will begin code execution from the bottom of the memory map.

The Memory Map View opens your default web browser to display the memory map information. An example is shown in the figure below.

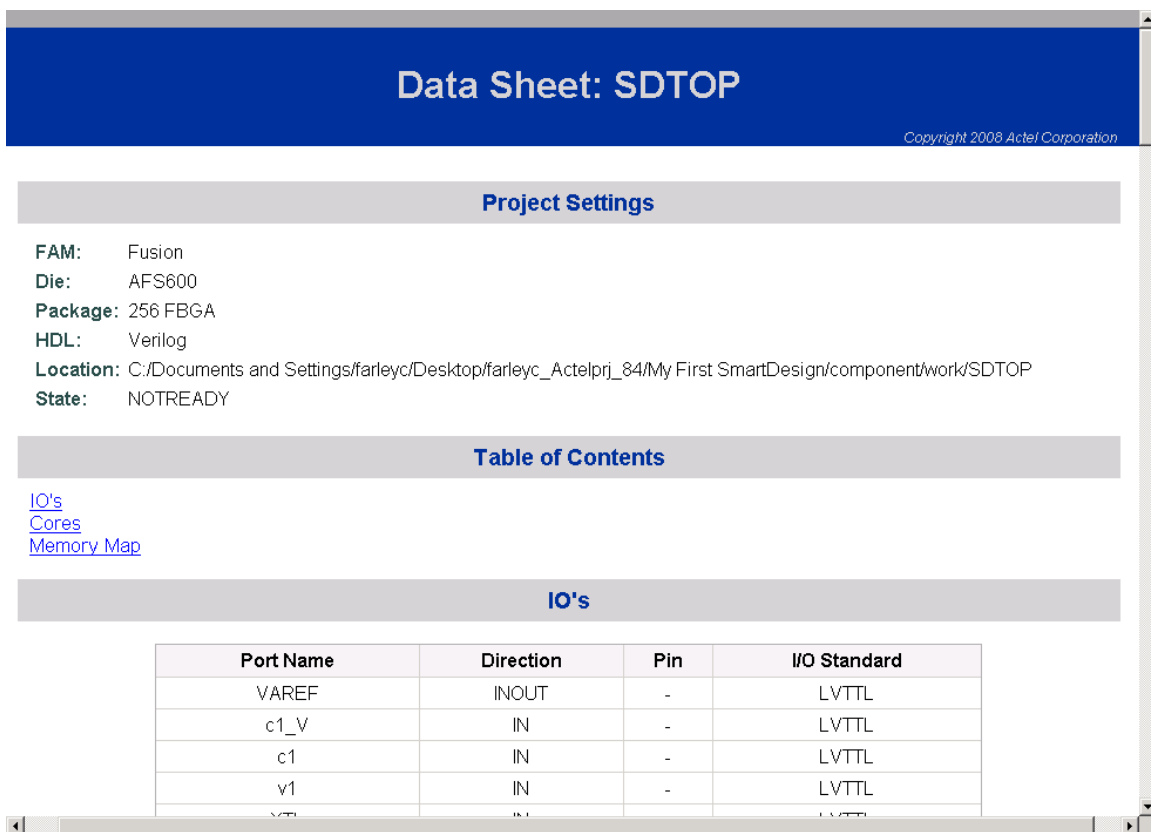

**Data Sheet: SDTOP**

Copyright 2008 Actel Corporation

**Project Settings**

FAM: Fusion  
 Die: AFS600  
 Package: 256 FBGA  
 HDL: Verilog  
 Location: C:/Documents and Settings/farleyc/Desktop/farleyc\_Actelprj\_84/My First SmartDesign/component/work/SDTOP  
 State: NOTREADY

**Table of Contents**

[IO's](#)  
[Cores](#)  
[Memory Map](#)

**IO's**

Port Name	Direction	Pin	I/O Standard
VAREF	INOUT	-	LVTTTL
c1_V	IN	-	LVTTTL
c1	IN	-	LVTTTL
v1	IN	-	LVTTTL
v2	IN	-	LVTTTL

Figure 26 · Example Memory Map

## Modify Memory Map Dialog Box

The Modify Memory Map dialog box (shown in the figure below) enables you to connect peripherals to buses via a drop-down menu. To open the dialog box, right-click on the Canvas or specific bus instance and choose **Modify Memory Map**.

This dialog simplifies connecting peripherals to specific base addresses on the bus. The dialog shows all the busses in the design; select a bus in the left pane to assign or view the peripherals on a bus. Busses that are bridged to other busses are shown beneath the bus in the hierarchy.

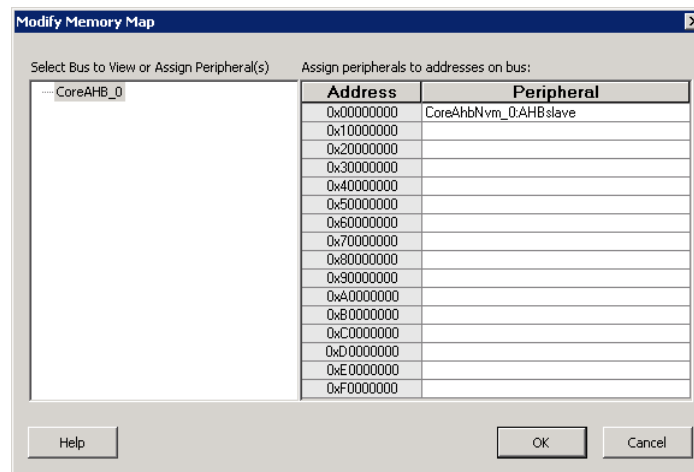

Figure 27 · Modify Memory Map Dialog Box

Click the Peripheral drop-down menu to select the peripheral you wish to assign to each address. To remove (unassign) a peripheral from an address, click the drop-down and select the empty element.

Click OK to create the connections between the busses and peripherals in the design.

## Finding Ports/Nets/Instances in SmartDesign

Use the [Find Window](#) to search for ports, nets, or instances in SmartDesign.

Searching for ports / nets / instances in SmartDesign highlights the objects on the Canvas.

## Convert CoreConsole Components

Your project contains components that were created by CoreConsole. CoreConsole is being replaced by SmartDesign, which incorporates the same functionality with enhanced features.

Actel recommends that you upgrade and convert your design.

The converted SmartDesign and/or IP Component is fully equivalent in terms of peripheral configuration and connectivity. In addition, your instance, port, and net names are preserved.

When you transition to SmartDesign, your CoreConsole design is converted to a SmartDesign and opened on the SmartDesign [Canvas](#). You must [regenerate your SmartDesign component](#) after you transition from CoreConsole.

Converting your component requires a re-synthesis of your design. If you have already completed your design and validation phase and are satisfied with your design then you can choose to continue using CoreConsole.

In SmartDesign you can drag configured cores onto the [Canvas](#) where they are viewed as blocks in a functional block diagram. From the Canvas you can:

- Make connections between your blocks
- Easily instantiate and connect HDL, Design Block (non-IP Catalog cores), and Actel macros
- View individual connection details
- Show or hide individual nets
- Set or clear attributes (such as Invert, Tie Low, Tie High, or Tie Open)
- Add slices
- Move, duplicate, or delete blocks
- Add notations such as labels, shapes, lines, or arrows to document your design
- Auto-stitching interfaces and other connections (such as AMBA)
- [Memory Map / Datasheet](#) - The datasheet reports the memory map of the different subsystems of your design, where a subsystem is any independent bus structure with a Master and Slave peripheral attached.

In certain situations, conversion may not produce a fully equivalent design. In this case, the following message appears in the log window:

Warning: A bus interface '<bus interface>' was found at the top level of component '<design>', the converted design may have different top level ports related to this bus interface. Please check your converted design.

This occurs because CoreConsole and SmartDesign have different rules when connecting bus interfaces to the top level. The design is still functionally the same, except it may have differently named ports related to that bus interface and you may have extra ports related to that bus interface. The extra ports are due to the fact that SmartDesign creates unique output ports in the bus interface even if they are connected to the same pin internally.

See the [SmartDesign FAQ](#) for more information on basic operations in CoreConsole and their SmartDesign equivalent. SmartDesign also has specific support for [working with processor-based designs](#).

## What to do if Conversion Fails

**If core(s) contained in the CoreConsole project are not downloaded into your vault:** You must download these cores into your vault and rerun the conversion. See the [Catalog help topic](#) for more information on downloading cores.

**If core(s) contained in the CoreConsole project are using the legacy IP-XACT loose generator interface (LGI) that is no longer supported:** Once the new versions of these cores are available, you can substitute the new version in your CoreConsole project and rerun the conversion. To rerun the conversion, close and reopen your Libero IDE project.

## Restore CoreConsole Components

If you converted your project by mistake you can restore your pre-converted CoreConsole component. Your original unconverted CoreConsole component is saved in a ZIP file in the Libero IDE project folder. The saved component is saved as <project>\coreconsole\<name>\_backup.zip

### **To restore your CoreConsole components:**

1. Delete the SmartDesign component from disk and project. Right-click the component and choose **Delete from Disk and Project**.
2. In Windows Explorer, navigate to the CoreConsole folder in your Libero IDE project folder. Double-click your component and unzip it to the local directory.
3. Import your unconverted CoreConsole project (CXF file) back into the Libero IDE. In the Project Manager, from the **File** menu, choose **Import Files** and select **Components (\*.cxf)** as the file type. Navigate to your unzipped CoreConsole component to select and Import.

# SmartDesign User Interface

## SmartDesign User Interface Overview

The SmartDesign tool is integrated into the [Libero IDE Project Manager](#).

The [Canvas](#) is the main work area for SmartDesign. The Canvas view displays a high-level block diagram of your design.

The [Grid](#) and [Schematic](#) views are available from the SmartDesign menu in the Project Manager. These views are not required to complete your design.

The Grid displays your design in a configurable spreadsheet, enabling you to specify detailed connections for each instance in your SmartDesign.

The Schematic View displays your design elements with port names, busses, and nets.

Changes made in one view will immediately be reflected in all other views, enabling you to quickly make and see changes to your design.

You can close each view by right-clicking the name of the view inside the SmartDesign tab and choosing **Close**.

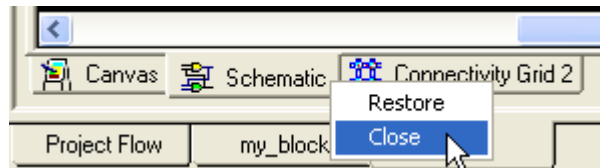

Figure 28 · Close the Active View

To re-open any view, from SmartDesign menu choose **Show Canvas View**, **Show Grid View**, or **Show Schematic View**.

---

# Canvas View

## Canvas Overview

The SmartDesign Canvas is like a whiteboard where functional blocks from various sources can be assembled and connected; interconnections between the blocks represent nets and busses in your design.

You can use the Canvas to manage connections, set attributes, add or remove components, etc. The Canvas displays all the pins for each instance (as shown in the figure below).

The Canvas enables you to drag a component from the [Hierarchy](#), [Files](#) list, or a core from the [Catalog](#) and add an instance of that component or core in the design. Some blocks (such as Basic Blocks) must be configured and generated before they are added to your Canvas. When you add/generate a new component it is automatically added to your Hierarchy.

To connect two pins on the Canvas, select any two pins on the Canvas (Ctrl + click to select a pin), right-click one of the pins you selected and choose Connect. The Connect is disabled if you attempt to illegally connect two pins.

Click the Maximize Work Area button  to hide the other windows and show more of the Canvas. Click the button again to return the work area to the original size.

The Canvas displays bus pins with a + sign (click to expand the list) or - (click to hide list). If you [add a slice](#) on a bus the Canvas adds a + to the bus pin.

Components can be [reconfigured](#) any time by double-clicking the instance on the Canvas. You can also [add bus interfaces to instances](#) using this view. In the Canvas view, you can [add graphic objects and text](#) to your design.

Inputs and bi-directional pins are shown on the left of components, and output pins are shown on the right.

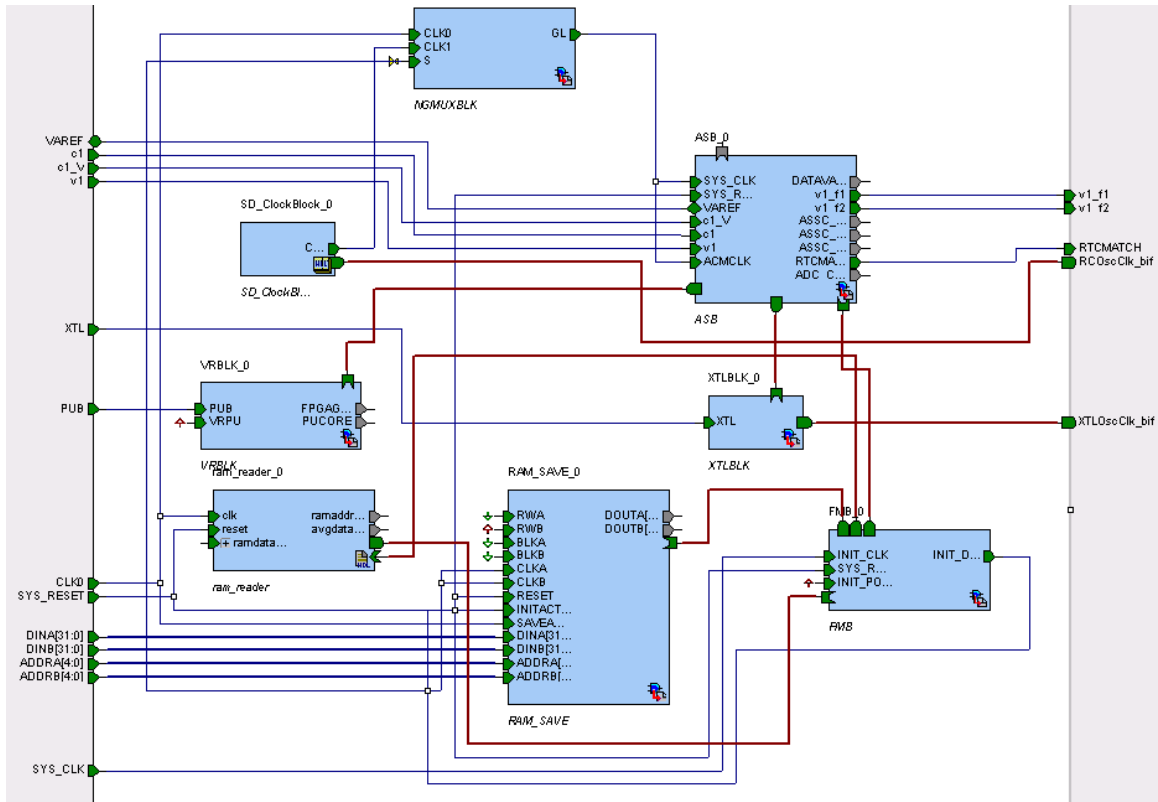

Figure 29 · SmartDesign Canvas

**See Also**

[Canvas icons](#)

## Displaying Connections on the Canvas

The Canvas shows the instances, pins, and nets in your design (as shown in the figure below).



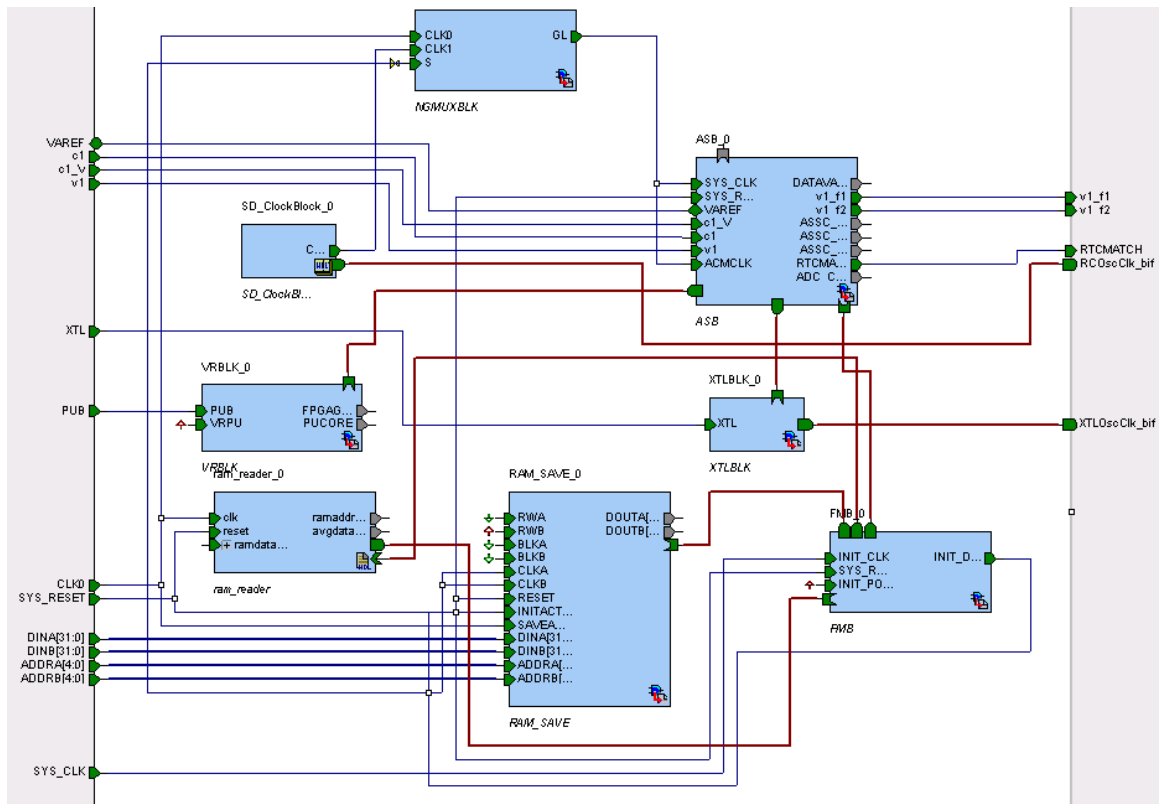

Figure 30 · Components in SmartDesign

Scalar net connections are shown in blue; bus net connections are dark blue.

Undriven nets are indicated by a blue dotted line.

### Pin and Attribute Icons

Unconnected pins that do not require a connection are gray.

Unconnected pins that require a connection are red.

Unconnected pins that have a default tie-off are pale green.

Connected pins are green.

Right-click a pin to assign an attribute.

Pins assigned attributes are shown with an icon, as shown in the table below.

Table 3 · Pin Attribute Icons

Attribute	Icon
Tie Low	
Tie High	

Attribute	Icon
Invert	▶
Mark as Unused	*

See the [Canvas Icons reference page](#) for definitions for each element on the Canvas.

Each connection made using a [bus interface](#) is shown in a separate connection known as a 'bus-interface net' (shown in brown lines).

Move the mouse over a bus interface to display its details (as shown below).

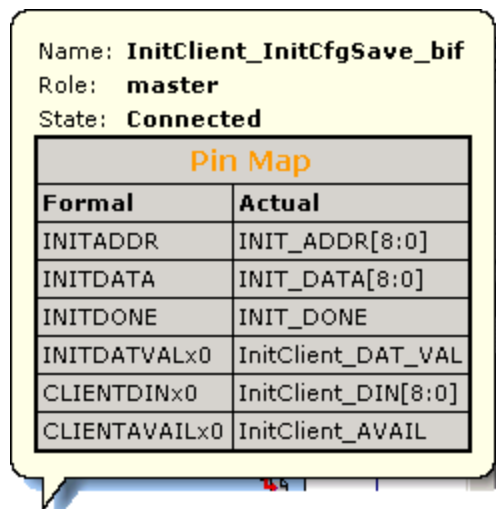

Name: **InitClient\_InitCfgSave\_bif**  
 Role: **master**  
 State: **Connected**

Pin Map	
Formal	Actual
INITADDR	INIT_ADDR[8:0]
INITDATA	INIT_DATA[8:0]
INITDONE	INIT_DONE
INITDATVALx0	InitClient_DAT_VAL
CLIENTDINx0	InitClient_DIN[8:0]
CLIENTAVAILx0	InitClient_AVAIL

Hover over a bus interface net to see details (as shown below).

## Making Connections Using the Canvas

Use the Canvas to make connections between instances.

To connect two pins on the Canvas, select any two (Ctrl + click to select a pin), right-click one of the pins you selected and choose Connect. Illegal connections are disabled; the Connect menu option is unavailable.

### Promoting Ports to Top Level

To automatically promote a port to top level, select the port, right-click, and choose **Promote To Top Level**. This automatically creates top-level ports of that name and connects the selected ports to them. If a port name already exists, a choice is given to either connect to the existing ports or to create a new port with a name <port name>\_<i> where i = 1...n.

Double-click a top-level port to rename it.

Bus slices cannot be automatically promoted to top level. You must create a top level port of the bus slice width and then manually connect the bus slice to the newly created top level port.

## Tying Off Input Pins

To tie off ports, select the port, right-click and choose **Tie High** or **Tie Low**.

## Tying to Constant

To tie off bus ports to a constant value, select the port, right-click and choose **Tie to a Constant**. A dialog appears (as shown in the figure below) and enables you to specify a hex value for the bus.

To remove the constant, right-click the pin and choose **Clear Attribute** or **Disconnect**.

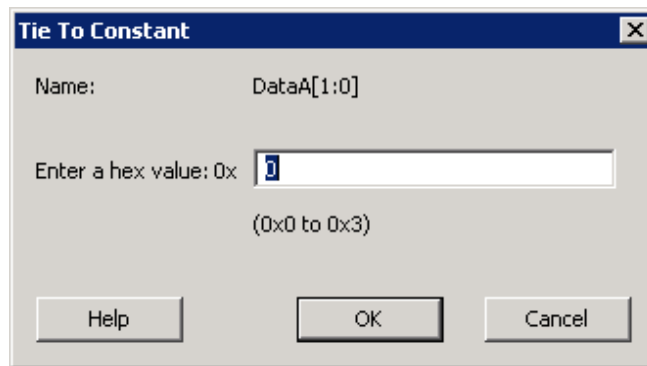

Figure 31 · Tie to Constant Dialog Box

## Making Driver and Bus Interface Pins Unused

Driver or bus interface pins can be marked unused (floating/dangling) if you do not intend to use them as a driver in the design. If you mark a pin as unused the Design Rules Check does not return Floating Driver or Unconnected Bus Interface messages on the pin.

Once a pin is explicitly marked as unused it cannot be used to drive any inputs. The unused attribute must be explicitly removed from the pin in order to connect it later. To mark a driver or bus interface pin as unused, right-click the driver or bus interface pin and choose [Mark as Unused](#).

### See Also

[Exposing Bus Interface Pins](#)

## Simplifying the Display of Pins on an Instance using Pin Groups

The Canvas enables you to group and ungroup pins on a single instance to simplify the display. This feature is useful when you have many pins in an instance, or if you want to group pins at the top level. Pin groups are cosmetic and affect only the Canvas view; other SmartDesign views and the underlying design are not affected by the pin groups.

Grouping pins enables you to:

- Hide pins that you have already connected
- Hide pins that you intend to work on later
- Group pins with similar functionality
- Group unused pins
- Promote several pins to Top Level at once

#### To group pins:

1. Ctrl + click to select the pins you wish to group. If you try to click-and-drag inside the instance you will move the instance on the canvas instead of selecting pins.
2. Right-click and choose **Add pins to group** to create a group. Click + to expand a group. The icon associated with the group indicates if the pins are connected, partially connected, or unconnected (as shown in the figure below).

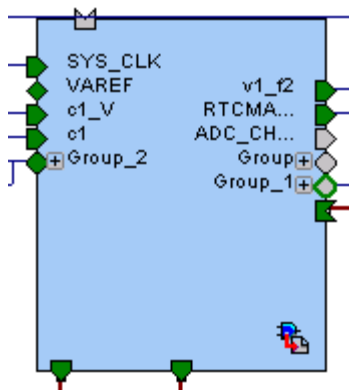

Figure 32 · Groups in an Instance on the Canvas

To add a pin to a group, Ctrl + click to select both the pin and the group, right-click and choose **Add pin to group**.

#### To name a group:

To name a group, click the group name on the instance and type in a different name.

#### To ungroup pins:

1. Click + to expand the group.
2. Right-click the pin you wish to remove from the group and choose **Ungroup selected pins**. Ctrl + click to select and remove more than one pin in a group.

A group remains in your instance after you remove all the pins. It has no effect on the instance; you can leave it if you wish to add pins to the group later, or you can right-click the group and choose **Delete** to remove it from your instance.

If you delete a group from your instance any pins still in the group are unaffected.

#### To promote a group to Top level:

1. Create a group of pins.
2. Right-click the group and choose Promote to Top level.

## Bus Instances

Bus Components in the Actel Core Catalog, such as CoreAHB or CoreAPB, implement an on-chip bus fabric. When these components are instantiated into your canvas they are displayed as horizontal or vertical lines. Double-click the bus interfaces of your component to edit the connections.

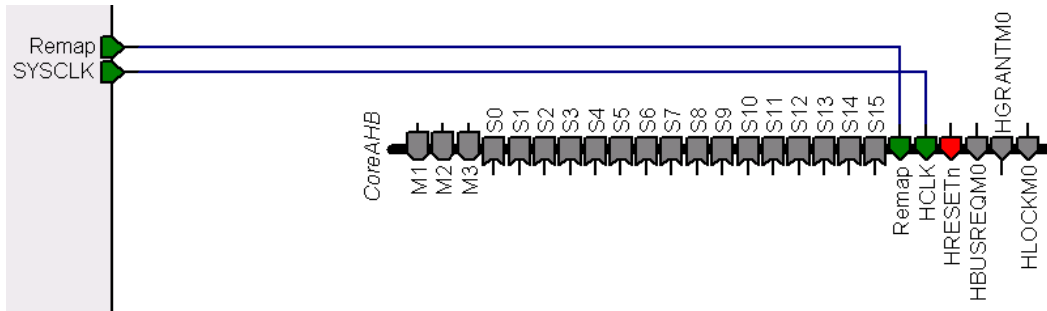

Figure 33 · Bus Instance in SmartDesign

## Positioning Busses on the Canvas

You may want to adjust the positioning and orientation of a bus on your canvas in order to organize the display of your design.

### Rotating Busses

Bus instances can be rotated ninety degrees (they must be horizontal or vertical). To rotate a bus instance ninety degrees left or right, right-click the black bar and choose **Shape > Rotate Left** (or Rotate Right).

### Flipping Busses

You can flip a bus along the horizontal or vertical axis. To flip a bus, right-click the black bar and choose **Shape > Flip Horizontal** (or Flip Vertical). Flipping a bus instance along an axis flips ALL the instances directly connected to the bus instance, except those that are connected to another bus instance.

## Adding Graphic Objects

You can document your design by adding comments and notations directly on the Canvas.

The Canvas toolbar (see figure below) enables you to add and modify decorative graphic objects, such as shapes, labels, lines, and arrows on the Canvas.







Figure 34 · Canvas Toolbar

## Adding and deleting lines and shapes

### To add a line or a shape:

1. Select the line or shape button.
2. Click, drag and release on the Canvas. The table below provides a description of each button.

Button	Description
	Line
	Arrow
	Rectangle
	Ellipse

**Note:** Hold the Shift key to constrain line and arrow to 45 degree increments or constrain the proportions of the rectangle (square) or ellipse (circle).

**To change the line and fill properties:**

1. Select the element(s), right-click it, and choose **Properties**.
  - Select **Line** to modify the color, style and width of the line.
  - Select **Fill** to modify the crosshatch and the foreground and background colors.
2. Click **OK**.

To delete a line or shape, select the object and press Delete.

## Adding text

To add text, select the text tool  and click the Canvas to create a text box. To modify the text, double-click the text box and then type.

**To modify the text box properties:**

1. Select the text box, right-click it, and choose **Properties**.
  - Select **Text** to modify the text alignment.
  - Select **Line** to modify the color, style and width of the line.
  - Select **Fill** to modify the crosshatch and the foreground and background colors.
  - Select **Font** to modify the font properties.
2. Click **OK**.

## Adding images



**To add an image to the canvas:**

1. Select the image button . The **Open** dialog box opens.

2. Select the image you want to add and click **OK**.
3. Select the image and place it in the desired location.



## Rotating elements

Select the element(s) you want to rotate and click the appropriate rotate button. See the table below for a description of each button.

Button	Description
	Free rotate
	Rotate to the left
	Rotate to the right





## Flipping elements



Select the element(s) you want to flip and click the appropriate flip button. See the table below for a description of each button.

Button	Description
	Flip vertically
	Flip horizontally

## Aligning elements

Select two or more elements on the Canvas and click the appropriate align button. See the table below for a description of each button.

Button	Description
	Align top
	Align middle
	Align bottom
	Align left

Button	Description
	Align center
	Align right

## Grouping graphic objects

Objects on the Canvas can be grouped and ungrouped.

To group two or more elements, select the elements, right-click, and choose **Grouping > Group**.

To ungroup two or more elements, select the elements, right-click, and choose **Grouping > Ungroup**.

## Ordering elements (Z-order)

Elements on the Canvas can be positioned in front or in back of each other.

To change the order of the element(s), select the element and from the right-click menu, choose **Order** and select one of the available options: **Bring to Front**, **Send to Back**, **Bring Forward**, or **Send Backward**.

## Auto-arranging Instances

The Auto Arrange Instances button  arranges the instances on the Canvas. You can also right-click the Canvas and choose **Auto Arrange Instances** from the right-click menu.

## Locking Instance Position

You can lock the placement of any instance on the Canvas. Right-click an instance and choose Lock Location to lock the placement. When you lock placement, the Auto Arrange Instances option has no effect on the instance.

To unlock an instance, right-click the instance and choose Unlock Location.

### See Also

[Bus instances](#)

[Auto-routing connections](#)

[Simplifying the Display of Pins on an Instance using Pin Groups](#)

## Auto-arrange Connections

The Auto Arrange Connections button  arranges the connections between instances. The way connections are drawn is highly dependent on the placement of the instances on the Canvas. The top-level connections are shown connected to the Top Level instance (green boxes).



Auto-arranging connections does not move instances; it places the nets between instances.

To auto-arrange your connections, right-click the canvas and choose **Auto arrange connections**.

**Note:** Note: Select a placement for your instances that is reasonable with respect to connections before using Auto Route.

## Replace Version for Instance

You can use the Replace Version for Instance dialog box (shown in the figure below) to restore or update version instances on your canvas without creating a new instance and losing your connections.

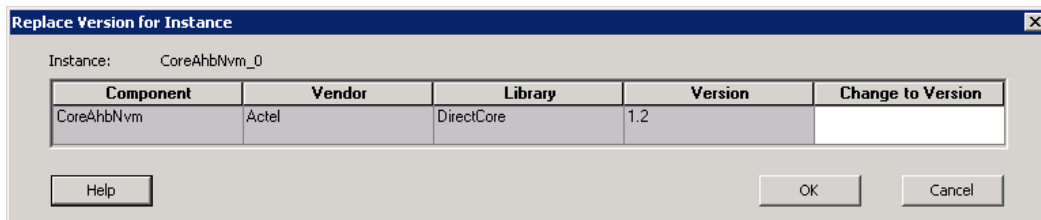

Figure 35 · Replace Version for Instance Dialog Box

### To change the version of an instance:

1. From the right-click menu choose **Replace Instance Version**. The Replace Version for Instance dialog box appears.
2. Choose a new version from the Change to Version drop-down menu. Click OK.

## Slicing

Bus ports can be sliced or split using Slicing. Then the sliced ports can be connected as regular ports.

### To create a slice:

1. Select a bus port, right-click, and choose **Add Slice**. This brings up the **Add Slice** dialog box (see figure below).

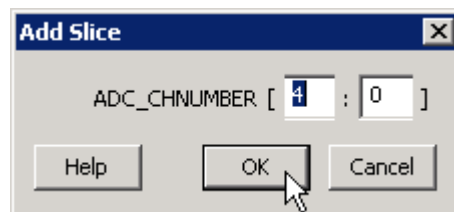

Figure 36 · Add Slice Dialog Box

2. Enter the parameters for the slice and click **OK**.

**Note:** Note: Once a slice is created, other bus ports or slices of compatible size can be connected to it. Overlapping slices cannot be created for IN and INOUT ports on instances or top-level OUT ports.

To remove a slice, select the slice, right-click, and choose **Delete Slice**.

## Instance Properties

Right-click a component instance and choose **Properties** to view the Name, Instance Name, and port information - name/direction-.

This dialog box is useful if you want to view the list of Port Names available in the instance from the Canvas view instead of the Grid.

### See Also

[Grid overview](#)

[Display panel](#)

[Connection panel](#)

## Rename Net

### To rename a net:

1. Right-click the net on the Canvas and choose **Rename Net**. This opens the Rename Net dialog box.
2. Type in a new name for the net.

**Note:** Note: The system automatically assigns net names to nets if they are not explicitly specified. Once you have specified a name for a net, that name will not be over-written by the system.

## Automatic Names of Nets

Nets are automatically assigned names by the tool according to the following rules:

### In order of priority

1. If user named then name = user name
2. If net is connected to top-level port then name = port name; if connected to multiple ports then pick first port
3. If the net has no driver, then name = net\_[i]
4. If the net has a driver, name = instanceName\_driverpinName

### Slices

For slices, name = instanceName\_driverpinName\_sliceRange; for example u0\_out1\_4to6.

### GND and VCC Nets

The default name for GND/VCC nets is net\_GND and net\_VCC.

### Expanded Nets for Bus Interface Connections

Expanded nets for bus interface connections are named busInterfaceNetName\_<i>\_driverPinName.

## Organizing Your Design on the Canvas

You may find it easier to create and navigate your SmartDesign if you organize and label the instances and busses on the Canvas.

You can show and hide nets, lock instances, rotate busses, group and ungroup pins, rename instances / groups / pins, and auto-arrange instances.

### **To organize your design:**

1. Click the [Auto-Arrange button](#) to automatically arrange instances on the Canvas. SmartDesign's auto-arrange feature optimizes instance location according to connections and instance size.
2. Right-click any instance and choose [Lock Location](#) to fix the placement. Auto-Arrange will not move any instances that are locked.
3. Click Auto-Arrange again to further organize any unlocked instances. Continue arranging and locking your instances until you are satisfied with the layout on the Canvas.

### **If your design becomes too cluttered:**

1. Hide the display of nets by de-selecting Canvas > Nets. This hides all the scalar and bus nets on your Canvas. You can also right-click a pin and choose Show Net (or Hide Net) to show/hide individual nets. Note that selecting a pin will make the corresponding net temporarily visible.
2. [Group your pins](#). It may help to group pins that are functionally similar, or to group pins that are already connected or will be unused in your design.

### **To further customize your design's appearance:**

1. Double-click the names of instances to add custom names. For example, it may be useful to rename an instance based on a value you have set in the instance: the purpose of an instance named 'array\_adder\_bus\_width\_5' is easier to remember than 'array\_adder\_0'.
2. Right-click any bus and choose Shape > Rotate Left or Right to change the bus orientation (horizontal or vertical). Click and drag the bus to a new location and lock, if necessary.

# Grid

## Grid Overview

The Grid (see image below) provides a mechanism for making manual connections between building blocks in your design. The grid displays your design in a spreadsheet for sorting and filtering, enabling you to quickly access and manipulate any subset of your design.

The Grid shows block instances vertically and horizontally on the spreadsheet, such that the port rows on the spreadsheet intersect with port columns. Each intersection of rows and ports on the spreadsheet provides a connection opportunity.

The grid is divided into two panels, the [Display panel](#) and the [Connection panel](#).

The Grid offers two different views: the [Instance-Instance view](#) and the [Net-Instance view](#). The behavior of the two panels is the same in both views.

The default display of the Grid shows connections between all the instances in your design in an Instance-Instance view.

Actel recommends that you work with only a subset of the instances in the current design when making manual connections. This greatly reduces the information displayed in the Grid view and makes it easier to create manual connections.

Click the Maximize Work Area button  to hide the other windows and show more of the Grid.

To create new Grids with just a subset of instances, select the instances between which you are making connections on the Canvas, then right-click and choose Edit Connections. A new Grid will be displayed, with only those instances and the top-level. When you are done making connections, right-click the grid view name tab and close the subset view.

To further simplify the data search in the grid and to make connections efficiently, use [Filtering](#), [Hierarchical sort](#) in the [instance-instance view](#), and the find unconnected ports (Hide All Connected Ports) features.

Display Panel				Connection Panel				
<input checked="" type="radio"/> Instance-Instance View <input type="radio"/> Net-Instance View				Attribute	SDTOP	Instances		
Instance	Port Name	Sl...	ASB_0			FMB_0	NGMUXBLK_0	
SDTOP	ADDRA	[4:0]						
	ADDRB	[4:0]						
	c1		PAD		c1			
	c1_V		PAD		c1_V			
	CLK0						CLK0	
	DINA	[31:0]						
	DINB	[31:0]						
	PUB		PAD					
	RCOscClk_bif		BIF					
	RTCMATCH				RTCMATCH			
	SYS_CLK					INIT_CLK		
	SYS_RESET				SYS_RESET	SYS_RESET		
	v1		PAD		v1			
	v1_f1				v1_f1			
	v1_f2				v1_f2			
	VAREF		PAD	VAREF	VAREF			
	XTL		PAD					
	XTLOscClk_bif		BIF					
ASB_0				4	8	2	1	
FMB_0				2	2	8	1	
NGMUXBLK_0	CLK0			CLK0				
	CLK1							
	GL				2			
	S							
ram_reader_0	avgdata	[11:0]				INIT_DONE		

Figure 37 · Grid (Instance-Instance View)

To switch to Net-Instance view, click the Net-Instance view radio button.

To reset to the default view, from the **Grid** menu, choose **Reset Instance [Net] View to Default**.

### See Also

[Grid - Display panel icons](#)

[Grid - Connection panel icons](#)

## Display Panel

You can use the fields in the Display panel to manage content. To add or remove a field, right-click the field title (such as Instance in the image below) and from the right-click menu choose **Fields**. New fields appear to the right of the fields already shown. To filter the list of nets or instances in the Display panel, use the [Custom Filter](#).

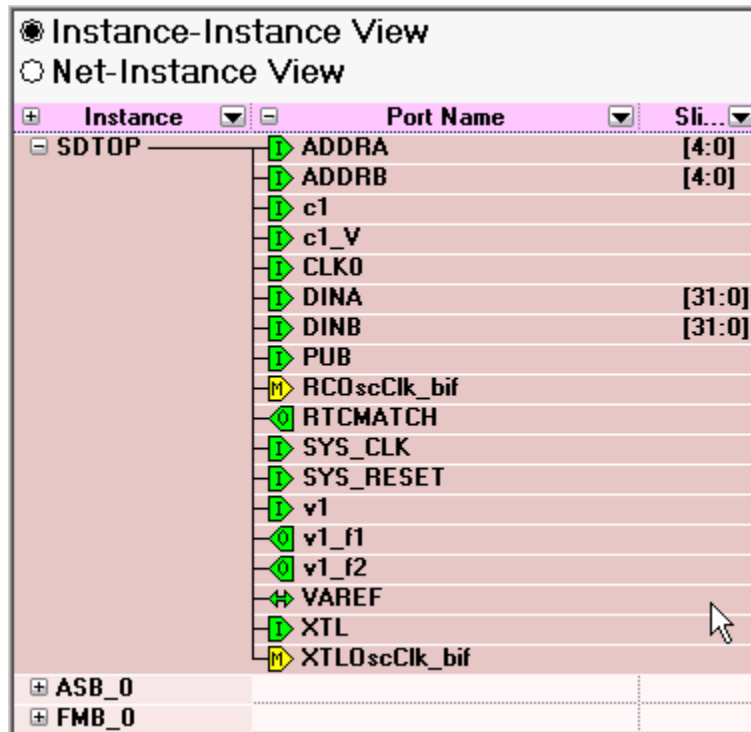





Figure 38 · Instance-Instance View Display Panel

The Display panel may list the following fields:

- **Instance:** Displays instances in the current design.
- **Direction:** Displays the port direction and bus interface type. Port directions are defined as IN, OUT and INOUT, bus interfaces are shown as MASTER, SLAVE, and SYSTEM.
- **Port Name:** Lists port names for all instances. Also displays an icon that indicates if the port is connected (green), disconnected (white), partially connected (green and white), input (I), output (O), master (yellow M), INOUT (small horizontal arrows), a system bif, or slave (S).
- **Slice:** Displays bit order (i.e. [7:0]) of busses and slices. Slice is not available for scalars and bus interfaces.
- **Width:** Displays the size of the bus for any bus port. One for a scalar and zero for a bus interface port.
- **Net:** Identifies the net for each instance connection.

Click the plus button  to expand the information listed for the selected instance or direction. Click the minus button  to collapse the information displayed for the selected instance or direction. You can [add and remove fields](#) to meet your needs.

Use the filter button  to [filter](#) the contents of each column. To sort the content of a column, click the **Filter** button and select **Sort Ascending** or **Sort Descending**. Choose **Custom Filter** to open the Custom Filter dialog box. You can use the [Custom Filter dialog box](#) to choose the nets, instances and slices you wish to display.

Right-click the column heading and choose **Fit This Column To Data** to expand (or shrink) the column to match the column width to the size of the field name.

## Promoting ports to top level

To automatically promote a port to top level, select the port, right-click, and choose **Promote To Top Level**. This automatically creates top-level ports of that name and connects the selected ports to them. If a port name already exists, a choice is given to either connect to the existing ports or to create a new port with a name <port name>\_<i>i</i> where  $i = 1 \dots n$ .

Bus slices cannot be automatically promoted to top level. You must create a top level port of the bus slice width and then manually connect the bus slice to the newly created top level port.

## Tying off input pins

Click in the Grid Attribute column and select Invert, Tie Low, or Tie High to tie the Port.

## Making driver and bus interface pins unused

Driver or bus interface pins can be marked unused (floating/dangling) if you do not intend to use them as a driver in the design. If you mark a pin as unused the Design Rules Check does not return Floating Driver or Unconnected Bus Interface messages on the pin.

Once a pin is explicitly marked as unused it cannot be used to drive any inputs. The unused attribute must be explicitly removed from the pin in order to connect it later. To mark a driver or bus interface pin as unused:

- Right-click the driver or bus interface pin and choose **Mark as Unused**
- In the Grid Attribute column, click the attribute and select **Mark as Unused**

## Finding unconnected and partially connected ports

The grid allows you to quickly find all the unconnected ports in your design. To filter the grid to only show these ports, from the SmartDesign menu, choose Grid > Hide All Connected Ports.

## Compatibility rules

- If the port selected on the row is a top-level port with a direction IN or an instance port with direction OUT, all ports of direction IN and INOUT on the instances are compatible with it.
- If the port selected on the row is a top-level port with direction OUT or instance port with direction IN or INOUT, all ports with direction IN are compatible with it.
- Bus ports or slices are only compatible with bus ports or slices of equal size.
- If there are no compatible connections between a port in the row area and an instance in the column area, the cell is shaded and unavailable.
- The pull-down menu in the cells only lists compatible ports.

**See Also**[Connection panel](#)[Making connections](#)[Filtering views](#)[Grid - Display panel icons](#)

## Connection Panel

The Connection panel (the area to the right side of the grid) shows the Attribute column, the "top" (top-level), and the Port Name to which the port is connected (if any).

Attribute	Top	Instances	
		Count8_0	my_block_0
PAD			AC1
PAD			AV0
PAD			AV1
PAD			PUB
	Aclr		SYS_RESET
			VRPU
PAD			XTL
PAD	VAREF		VAREF
	0	1	12
	SYS_R		
	Q[7:4]		
BIF	1	1	1
BIF			

Figure 39 · Instance-Instance Connection Panel

Use the filter  button to [filter](#) and select which columns you wish to view, or to sort the contents of the columns in ascending or descending order.

## Attribute Column

The attribute column specifies additional properties of a port on the instance. These are:

**PAD** - Indicates that the port is a chip-level package pin. In SmartDesign, these ports are automatically promoted to the top-level and are read only.

**BIF** - Indicates that the port is a Bus Interface.

**GND**  - Tie the port to logic 0.

**VCC** - Tie the port to logic 1.



**Invert** - Invert the polarity of this port. Inverting a port automatically instantiates an inverter into the generated HDL file:

- For a driver: Inverter added after pin or port.
- For a non-driver: Inverter added before pin or port.

**Unused** - Indicates the pin has been assigned the float attribute and is not included in the Design Rules Check.

## <design name> Column

The <design name> column represents the top-level; the name of the column depends on the name of your design.

## Instances Column(s)

An instance column represents an instance that an instance-port of a row can be connected to.

### See Also

[Display panel](#)

[Making connections](#)

[Filtering views](#)

[Grid - Connection panel icons](#)

# Instance-Instance View

## Instance-Instance View

The Instance-Instance view (see figure below) is divided into two panels: the [Display panel](#) and the [Connection panel](#). By default, the Display panel shows Instance, Port Name, and Slice information.

By default, the Connection panel begins at the Attribute column, and lists instances in the design and their ports. You can show/hide any column in either panel; if you modify the view and wish to reset it, right-click the Instance-Instance View radio button in the Display panel and choose **Reset Instance View to Default**.

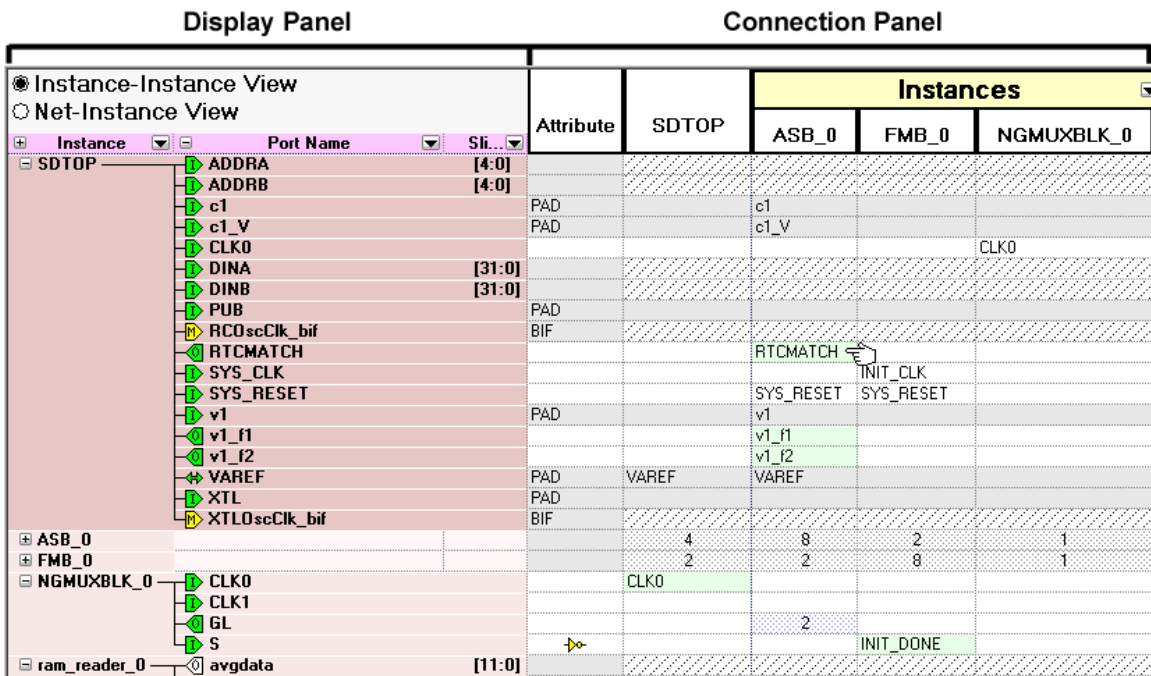

Figure 40 · Instance - Instance View

## Adding and Removing Fields

To add a field in the Display panel, right-click the field title (such as Direction in the image below) and from the right-click menu choose **Field**, and select the field you wish to add or remove. Added fields appear at the end of the list of fields.

You can add fields to view additional information about a port. Also, adding the field enables you to [Sort](#) your design based on fields.

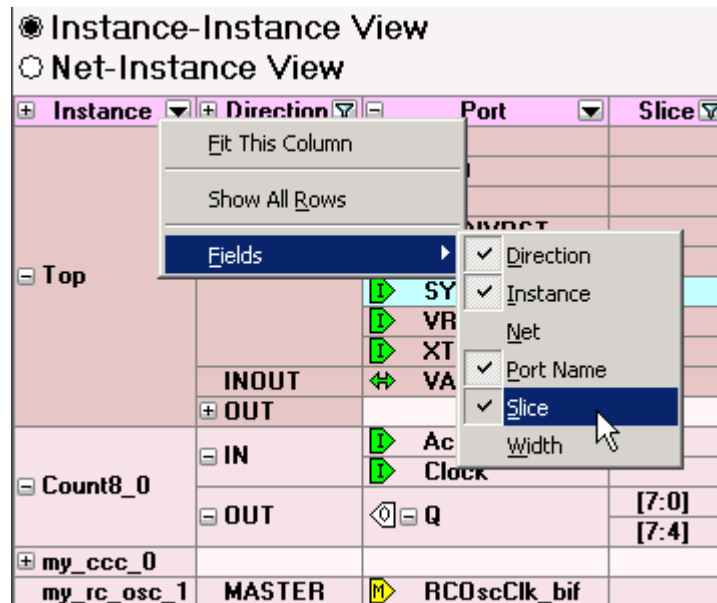

Figure 41 · Add Field Menu in Display Panel

To add an instance in the Connection panel, click the drop-down arrow in Instances (as shown in the figure below), and choose **Custom Filter**. The [Custom Filter](#) dialog box appears. Select checkbox for the instance you wish to view, or use the Find box to search for a specific instance or range of instances.

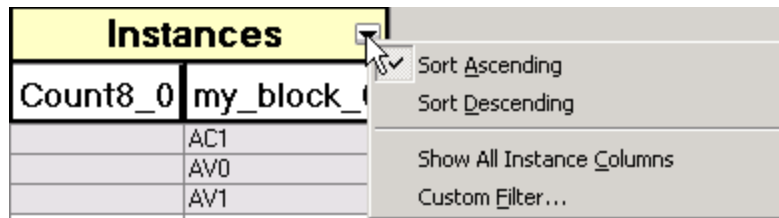

Figure 42 · Add an Instance with Custom Filter in Connection Panel

## Sorting with Fields

The field columns inside the Grid can be used to sort the ports in your design.

The hierarchical order is defined by the order of the columns (left to right). The data within each field is sorted alphabetically. To change the hierarchical view, select a column and drag the column to the left or the right.

For example, this may be useful if you wish to see all of your INPUT ports together or if you want to see all of your 8-bit busses together. The image below shows the Display Panel sorted by Port Name.

Instance-Instance View  
 Net-Instance View

Port Name	Width	Net
A_RC0scClk_bif	0	net_6
AC1	1	net_3
AC1_Over1a	1	net_17
AC1_Under1a	1	net_15
Aclr	1	net_8
ASSC_CHLATD	1	net_9
ASSC_CHSAT	1	net_13
ASSC_DONE	1	net_20
ASSC_WAIT	1	net_16
AV0	1	net_2
AV0_Over1p5	1	net_18
AV0_Over2p5	1	net_19
AV0_Over3p3	1	net_14
AV0_Over5p0	1	net_11
AV1	1	net_1
AV1_Over3p3	1	net_12
AV1_Under3p3	1	net_10
Clock	1	net_24
FPGAGOOD	1	
GLA	1	net_24
LOCK	1	

Figure 43 · Display Panel Sorted by Port Name

## Making Connections using the Grid

### To make connections between ports on two instances:

1. Click in the intersection between the port (row) and the instance (column). SmartDesign displays a drop-down list of compatible ports from the instance on the column area.
2. Select the desired port to make the connection. In the figure below, the port SYS\_RESET from the instance Top is being connected to port Aclr in the instance Count8\_0. Note that the unconnected ports are shown in white.

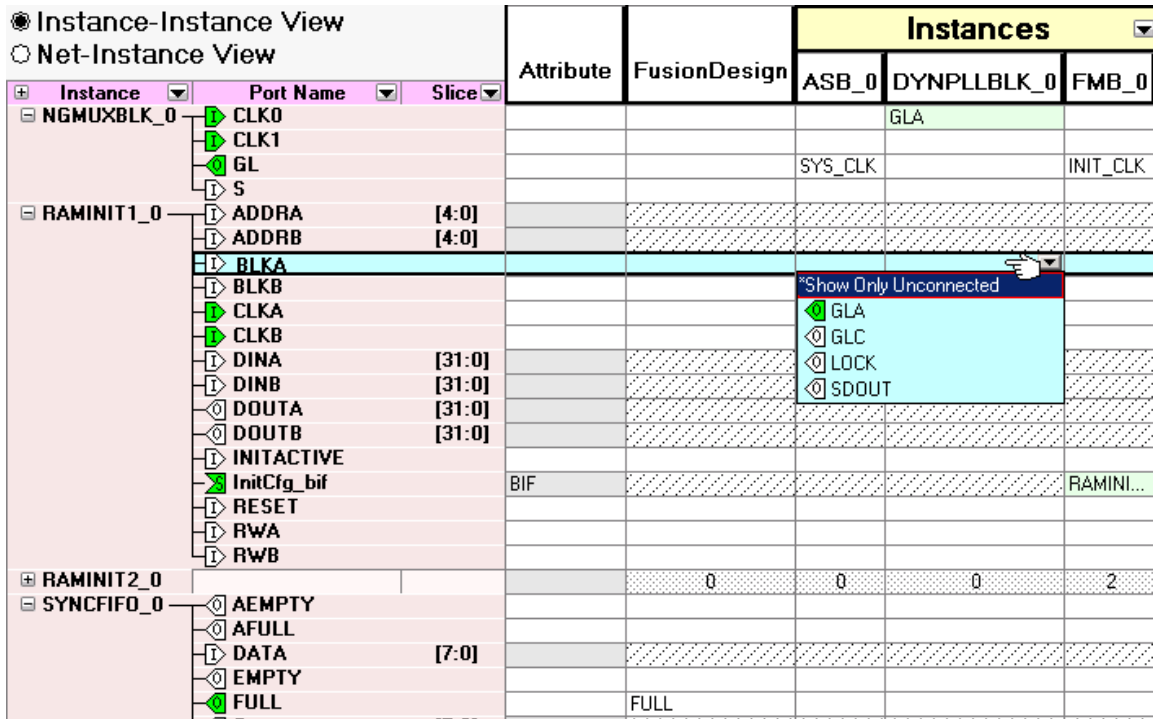

Figure 44 · Making Connections Between Two Ports on Two Instances

To disconnect an existing connection, click in the intersection between the port and the instance and choose **Disconnect**.

### See Also

[Connecting multiple ports \(Connection panel\)](#)

[Filtering views](#)

## Connecting Multiple Pins (Connection Panel)

The Connect Multiple dialog box enables you to make multiple connections to a pin or net.

In the Instance to Instance view you can easily connect multiple non-driver pins from a single instance to a driver pin.

To do so:

1. Click a cell intersection of a driver pin and you will see a drop down with **Connect Multiple**. Choose **Connect Multiple** to open the dialog box below.

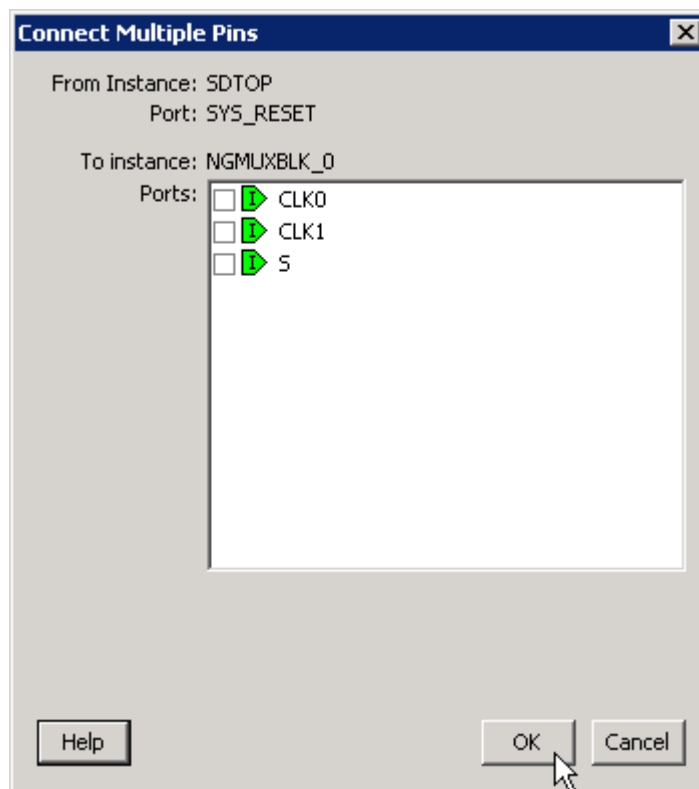

Figure 45 · Connect Multiple Pins Dialog Box - Instance to Instance

2. The dialog box lists all the compatible non-driver pins that can be connected to the selected driver pin. Click the checkbox to connect these pins to the driver pin.

In the Net to Instance view you can easily connect multiple pins from a single instance to a net. To do so:

1. Click a cell intersection of an existing net and you will see a drop down with **Connect Multiple**. Choose **Connect Multiple** to open the dialog box below. The dialog box lists all the compatible non-driver pins that can be connected to this net.

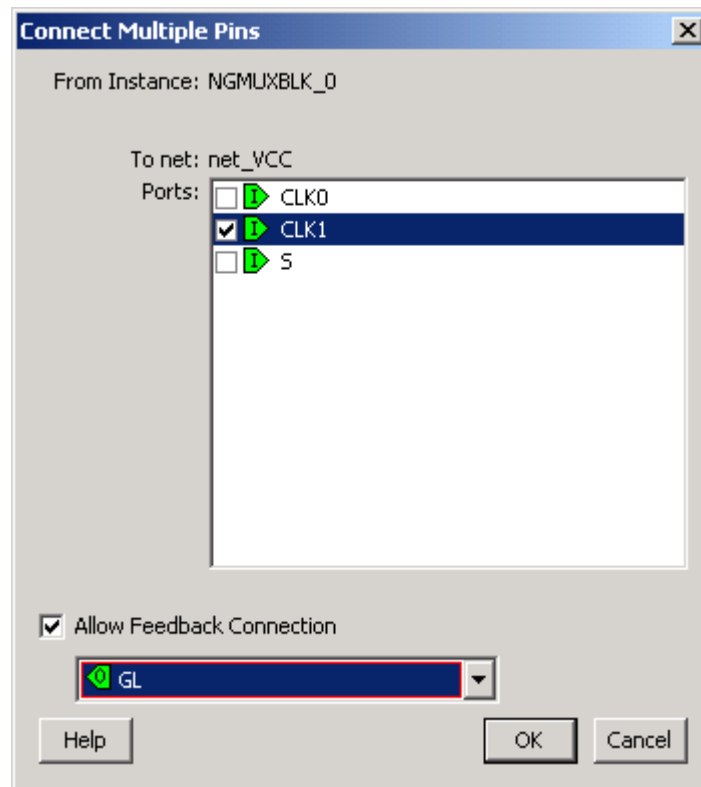

Figure 46 · Connect Multiple Pins Dialog Box - Net to Instance

2. Click the checkbox to connect these pins onto the net.
3. If the instance has driver pins available, you can click the checkbox for **Allow Feedback Connection** to select the driver pin for this net.

### See Also

[Filtering views](#)

[Connection panel](#)

## Net-Instance View

The Net-Instance view is a simplified version of the Instance-Instance view. Instead of an expandable list of every instance in your SmartDesign, the Display panel lists only the net names that are connected to an instance. This view is useful if you wish to see which nets are connected to an instance without changing your settings in the Instance-Instance view. The Display and Connection panels in the Net-Instance view behave the same in both views.

The default Display panel in Net-Instance view lists the nets in your design; the default Connection panel lists all instances (see figure below).

<input type="radio"/> Instance-Instance View <input checked="" type="radio"/> Net-Instance View		SDTOP	Instances			
Net	Slice		GND	NGMUXBLK_0	ram_reader_0	RAM_SAVE_0
ASB_0_RTCMATCH		RTCMATCH				
ASB_0_RTCVR_bif						
ASB_0_RTCXTL_bif						
ASB_0_v1_f1		v1_f1				
ASB_0_v1_f2		v1_f2				
FMB_0_INIT_DONE			S			SAVEACTIVE
FMB_0_InitCfgAnalog_bif						
FMB_0_InitClient_InitCfgSave_bif					InitCfgSave_bif	
FMB_0_RAM_SAVE_InitCfgSave_bif						InitCfgSave_bif
net_1		VAREF				
net_GND	[8] [7] [6] [5] [4] [3] [2] [1] [0]		Y		ramdata[1]	BLKA

Figure 47 · Net-Instance View, Display and Connection Panels

To switch to Net-Instance view, click the **Net-Instance** radio button. To reset to the default view, from the **Grid** menu, choose **Reset Net View to Default**.

**See Also**

- [Connect to an existing net \(Net-Instance view\)](#)
- [Connection panel](#)
- [Display panel](#)
- [Filtering views](#)

## Connect to an Existing Net (Net-Instance View)

To connect to an existing net, select the ports to be connected from the drop-down list by clicking in the cell at the intersection of the net and the instance (see figure below).



<input type="radio"/> Instance-Instance View <input checked="" type="radio"/> Net-Instance View		Top	Instances		
Net	Slice		Count8_0	my_block_0	my_ccc_0
net_2		AV0		AV0	
net_20		ASSC_DONE		ASSC_DONE	
net_21		OADIVRST			
net_22					
net_23	[7:4]	Q[7:4]	Q[7:4]		
net_24			Clock	SYS_C	
net_3		AC1		AC1	
net_4		XTL		XTL	
net_5		PUB		PUB	
net_6					A_RCOscClk_bif
net_7		VRPU		VRPU	
net_8		SYS_RESET	Aclr	SYS_RESET	
net_9		ASSC_CHLATD		ASSC_CHLATD	

Figure 48 · Connecting to an Existing Net

Any net can have at most one driver. IN ports of the top-level or OUT ports from instances are considered drivers. If another driver is for an already driven net, the current driver will be disconnected and the new driver will be connected to the selected net.

**See Also**

[Connection panel](#)

[Display panel](#)

## Make New Connection (Net-Instance View)

To connect to a new net, select the ports to be connected from the drop-down list. Click the cell at the intersection of the (unconnected) net row and the instance. This creates a new net (see figure below).

Instance-Instance View

Net-Instance View

Net	Slice	Instances					S
		FusionDesign	GND	NGMUXBLK_0	RAMINIT1_0	RAMINIT2_0	
ASB_0_RTCVR_bif							
ASB_0_RTCXTL_bif							
DYNPLLBLK_0_GLA			CLK0				
DYNPLLBLK_0_GLC							
FMB_0_InitCfgAnalog_bif							
FMB_0_RAMINIT1_InitCfg...					InitCfg_bif		
FMB_0_RAMINIT2_InitCfg...						InitCfg_bif	
INIT_ACM_RTC_WEN		INIT_ACM_RTC_WEN	CLK1				
<b>FULL</b>		<b>FULL</b>					<b>FL</b>
net_VCC							
NGMUXBLK_0_GL			GL			BLKB	W
PUB		PUB					
SYS_RESET		SYS_RESET					RI
v1		v1					
VAREF		VAREF					
XTL		XTL					
(unconnected)							

Connect Multiple...

- \*Show All
- ▶ BLKA
- ▶ BLKB
- ▶ INITACTIVE
- ▶ RESET
- ▶ RWA
- ▶ RWB

Figure 49 · Making a New Connection

**See Also**

- [Connect to an existing net \(Net-Instance view\)](#)
- [Connection panel](#)
- [Display panel](#)

## Filtering Views

To reduce the amount of data shown on the screen, you can display it selectively. The easiest way to hide an entry is to right-click the cell and choose **Hide Selection**. To show the entry again, you can right-click at the top and choose **Show All Rows**.

For more control over the data display, use the Custom Filter available from the button on the header row.

The Grid enables you to filter all instances within the design, as well as their direction, ports and slices. The example below filters by instance, but you can filter any column in the Display panel with the same procedure.

**To filter the contents in the grid:**

1. Use the filter button and choose **Custom Filter** to bring up the filter box (see figure below).

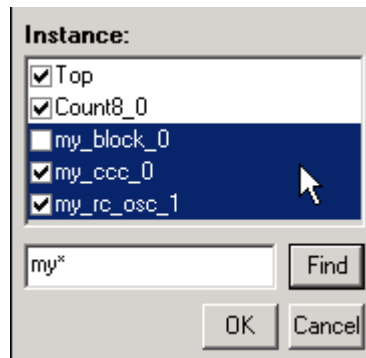

Figure 50 · Custom Filter Box in the Display Panel

2. From the filter box, you can find and select multiple values. In the image above, the Find field has highlighted all the instances that start with 'my', \* is a wildcard. You must click inside the checkbox to select, or de-select, highlighted values.
3. Click OK to commit your changes.

**To hide data in the grid:**

Select the rows you want to hide, right-click and choose **Hide Selection**.

**To restore grid data:**

From the **SmartDesign** menu, choose **Connectivity View > Reset Instance View to Default**.

**See Also**

[Connection panel](#)

[Display panel](#)

[Making connections](#)

# Schematic View

## Schematic Overview

The Schematic view (see figure below) displays a detailed connection diagram for all instances, ports, and pins in the current design with lines representing nets. This view is the closest representation to the exported HDL.

You can [zoom](#) the contents in the Schematic view or [split the Schematic view into multiple pages](#).

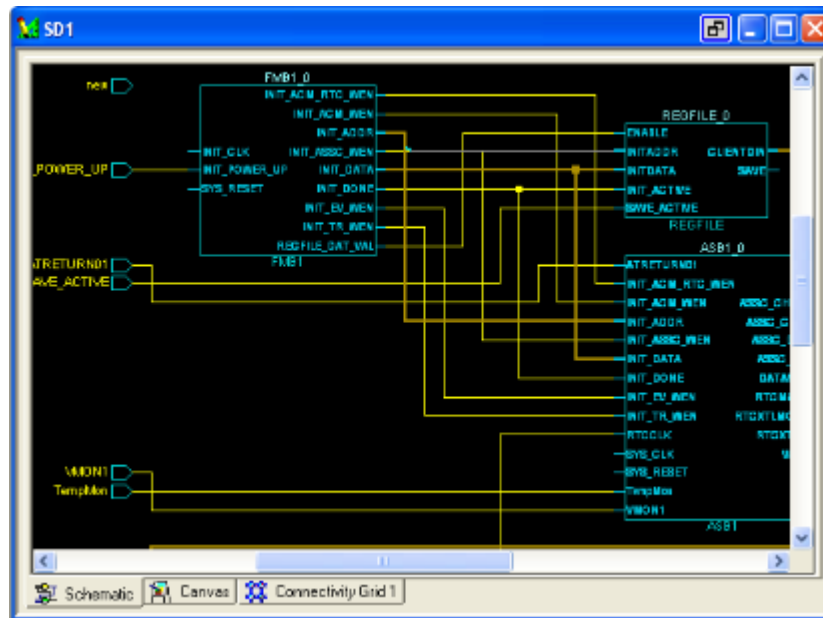

Figure 51 · Schematic View

## Page Splitting

By default, the Schematic view displays large designs using multiple pages. Page splitting enables you to quickly compute and display the schematic. You can turn off page splitting to view your entire design on a single page. For larger designs, when this option is turned off, it may take SmartDesign longer to display the schematic.

To turn page splitting on or off, from the **SmartDesign** menu, choose **Schematic View > Allow Page Splitting**.

To navigate to the next page in a design, from the **SmartDesign** menu, choose **Schematic View > Go to Next Page**.

To navigate to the previous page, from the **SmartDesign** menu, choose **Schematic View > Go to Previous Page**.

To navigate to the first page, from the **SmartDesign** menu, choose **Schematic View > Go to First Page**.

To navigate to the last page, from the **SmartDesign** menu, choose **Schematic View > Go to Last Page**.

## Zooming

The zoom tool in the [Schematic View](#) enables you to zoom fit the contents of your design within the window.

To zoom fit the design, click and drag to the bottom left corner of the window.

Zoom in and out of your schematic using the zoom icons on your toolbar.

---

# Creating a SmartDesign

## Adding Components and Modules (Instantiating)

SmartDesign components, Design Block cores, IP cores, and HDL modules are displayed in the [Hierarchy](#), [Files](#), and [Find output window](#).

**To add a component, do either of the following:**

- Select the component and drag it to the [Canvas](#) or [Grid](#).
- Select a component, right-click, and choose **Instantiate in SmartDesign <name>**.

The component is instantiated in the design.

SmartDesign creates a default instance name. To rename the instance, double-click the instance name in the canvas.

**Note:** Note: HDL modules with syntax errors cannot be instantiated in SmartDesign. However, since SmartDesign requires only the port definitions, the logic causing syntax errors can be temporarily commented out to allow instantiation of the component.

## Adding a SmartDesign Component in a Higher-level Design (Instantiating)

SmartDesign components can be instantiated into another SmartDesign component.

Once a SmartDesign is generated, the exported netlist can be instantiated into HDL like any other HDL module.

## Adding Top Level Ports / Renaming External Pads in a SmartDesign

You can add ports to, and/or rename ports in your SmartDesign.

### Add Prefixes to Bus Interface / Group Names on Top-level Ports:

Bus Interfaces and Groups are composed of other ports. On the top level, you can add prefixes to the group or bus interface port name to the sub-port names. To do so, right-click the group or bus interface port and choose **Prefix <name> to Port Names**.

### Adding/Renaming Ports

**To add ports:**

1. From the **SmartDesign** menu, choose **Logic > Add port**. The Add Port dialog box appears (as shown below).

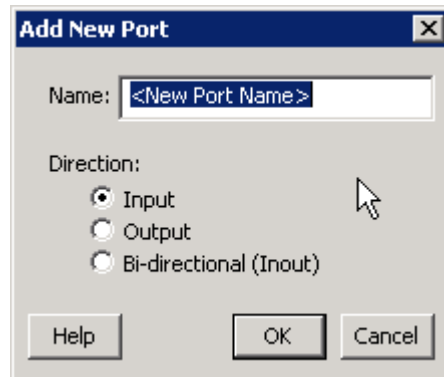

Figure 52 · Add New Port Dialog Box

2. Specify the name of the port you wish to add. You can specify a bus port by indicating the bus width directly into the name using brackets [ ], such as mybus[3:0].
3. Select the direction of the port.

To remove a port from the top level, select the port in the Grid, right-click and choose **Delete Top Level Port**.

To rename a top-level port, right-click the top-level non-pad port and choose **Modify Top Level Port**. You can rename the port, change the bus width (if the port is a bus), and change the port direction.

#### **To rename an external pad:**

1. Right-click a pad in the top-level port and select **Rename External Pad**. The Rename External Pad dialog box appears, as shown in the figure below.

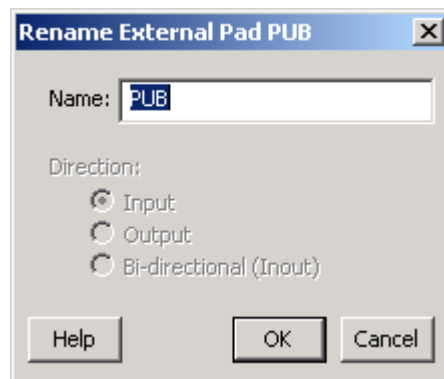

Figure 53 · Rename External Pad Dialog Box

2. Enter the new name for the external pad and click **OK**.

#### **See Also**

[Top level connections](#)

# Connecting Instances

## Automatic Connections

Using automatic connections (as shown in the figure below) enables the software to connect your design efficiently, reducing time required for manual connections and the possibility of introducing errors.

To auto connect the bus interfaces in your design, right-click the design Canvas and select **Auto Connect**, click the Auto Connect button ; or from the **SmartDesign** menu, choose **Auto Connect**.

You can select individual pins or groups on the Canvas to auto-connect. Select the pins, right-click and choose Auto Connect.

SmartDesign searches your design and connects all [compatible bus interfaces](#).

SmartDesign will also form known connections for any SoC systems such as the processor CLK and RESET signals.

If there are multiple potential interfaces for a particular bus interface, Auto Connect will not attempt to make a connection; you must connect manually. You can use the [Canvas, Grid](#) or the [Find Compatible Bus Interface](#) dialog box to make the manual connection.

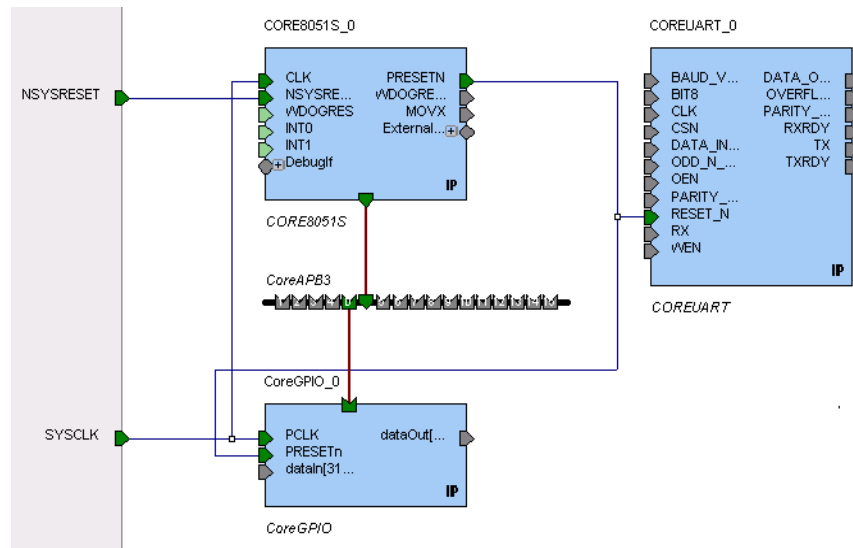

Figure 54 · Auto-Connected IP Cores

## Manual Connections

To make manual connections between two pins on the Canvas, select both pins (use CTRL + click), right-click either pin and choose **Connect**. If the pins cannot be legally connected the connection will fail.



## Deleting Connections

To delete a net connection on the Canvas, click to select the net and press the Delete key, or right-click and choose **Delete**.

To remove all connections from one or more instances on the Canvas, select the instances on the Canvas, right-click and choose **Clear all Connections**. This disconnects all connections that can be disconnected legally.

You can also select one or more rows in the Grid and choose **Remove Connections from Selected Ports** from the right-click menu to remove the connects for a group of Ports.

If you click in a cell displaying a connection, selecting **Disconnect** from the drop down removes just that connection.

Certain connections to ports with PAD properties cannot be disconnected. PAD ports must be connected to a design's top level port. PAD ports will eventually be assigned to a package pin. In SmartDesign, these ports are automatically promoted to the top level and cannot be modified or disconnected.

## Top-level Connections

Connections between instances of your design normally require an OUTPUT (Driver Pin) on one instance to one or more INPUT(s) on other instances. This is the basic connection rule that is applied when connecting.

However, directions of ports at the top level are specified from an external viewpoint of that module. For example, an INPUT on the top level is actually sending ('driving') signals to instances of components in your design. An OUTPUT on the top level is receiving ('sinking') data from a Driver Pin on an internal component instance in your SmartDesign design.

The implied direction is essentially reversed at the top-level. Making connections from an OUTPUT of a component instance to an OUTPUT of top-level is legal.

This same concept applies for bus interfaces; with normal instance to instance connections, a MASTER drives a SLAVE interface. However, they go through a similar reversal on the top-level.

---

# Bus Interfaces

## About Bus Interfaces

A bus interface is a standard mechanism for specifying the interconnect rules between components or instances in a design. A bus definition consists of the roles, signals, and rules that define that bus type. A bus interface is the instantiation of that bus definition onto a component or instance.

The available roles of a bus definition are master, slave, and system.

A master is the bus interface that initiates a transaction (such as read or write) on a bus.

A slave is the bus interface that terminates/consumes a transaction initiated by a master interface.

A system is the bus interface that does not have a simple input/output relationship on both master/slave. This could include signals that only drive the master interface, or only drive the slave interface, or drive both the master and slave interfaces. A bus definition can have zero or more system roles. Each system role is further defined by a group name. For example, you may have a system role for your arbitration logic, and another for your clock and reset signals.

Mirror roles are for bus interfaces that are on a bus core, such as CoreAHB or CoreAPB. They are equivalent in signal definition to their respective non-mirror version except that the signal directions are reversed.

The diagram below is a conceptual view of a bus definition.

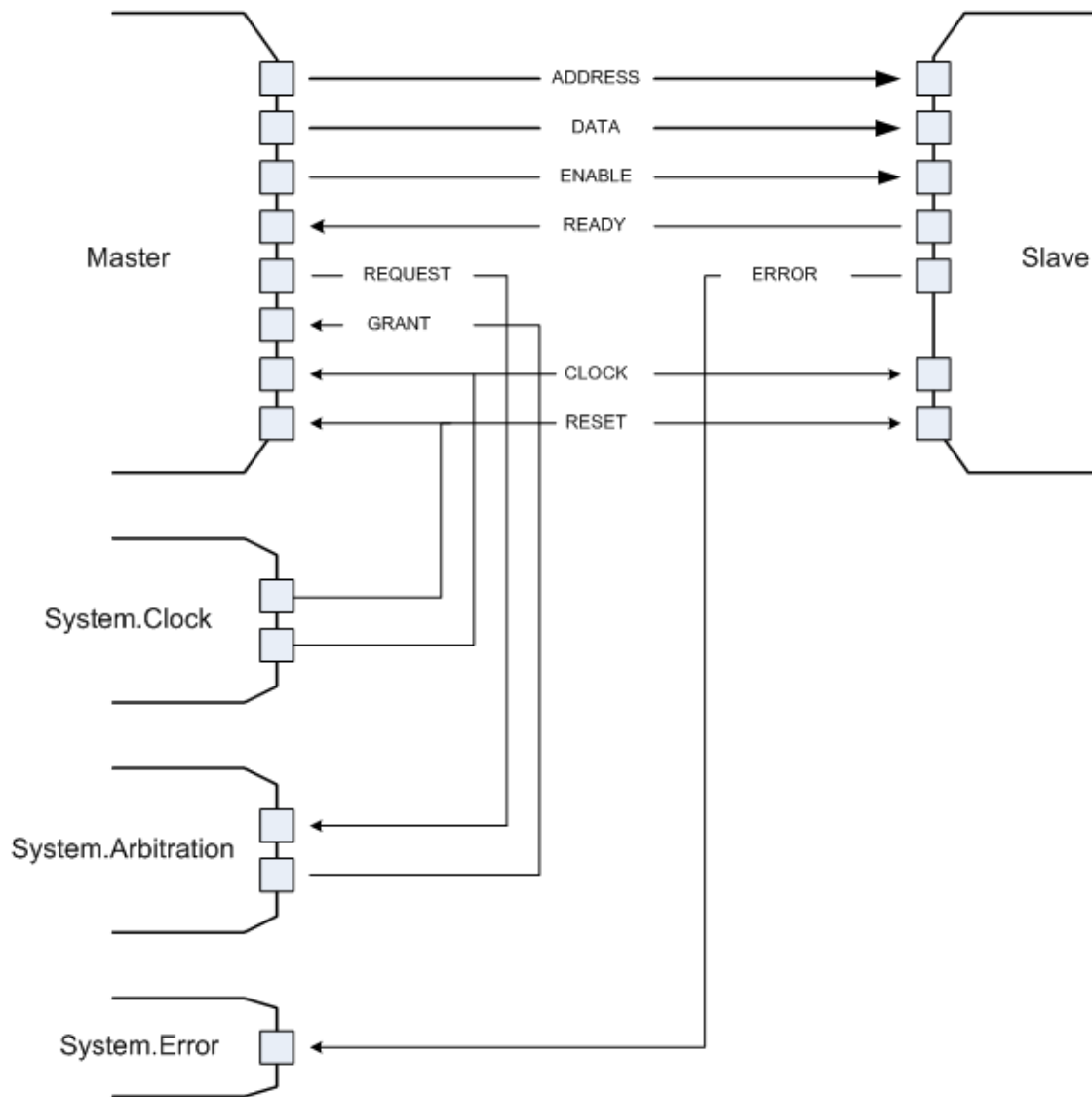

Figure 55 · Bus Definition

**See Also:**

[Using bus interfaces in SmartDesign](#)

## Using Bus Interfaces in SmartDesign

Adding bus interfaces to your design enables SmartDesign to do the following:

- Auto connect compatible interfaces
- Enforce DRC rules between instances in your design

- Search for compatible components in the project

The [Catalog](#) in the Project Manager contains a list of Actel-specific and industry standard bus definitions, such as AMBA.

You can [add bus interfaces](#) to your design by dragging the bus definitions from the Bus Definitions tab in the Catalog onto your instances inside SmartDesign.

Some Actel cores have bus interfaces that are instantiated during generation.

Certain bus definitions cannot be instantiated by a user. Typically these are the bus definitions that define a hardwired connection and are specifically tied to a core/macro. They are still available in the catalog for you to view their properties, but you will not be able to add them onto your own instances or components. These bus definitions are grayed out in the Catalog.

A hardwired connection is a required silicon interconnect that must be present and specifically tied to a core/macro. For example, when using the Real Time Counter in a Fusion design you must also connect it to a Crystal Oscillator core.

**Maximum masters allowed** - Indicates how many masters are allowed on the bus.

**Maximum slaves allowed** - Indicates how many slaves are allowed on the bus.

**Default value** - indicates the value that the input signal will be tied to if unused. See [Default tie-offs with bus interfaces](#).

**Required connection** - Indicates if this bus interface must be connected for a legal design.

Hover your mouse over a bus definition in the Project Manager Bus Definition Catalog to view the masters/slave/default/required connection information.

## Adding Bus Interfaces to SmartDesign Components

### **To add a bus interface to a component:**

1. Select a bus definition from the Bus Definitions tab in the [Catalog](#) and drag it onto your top-level. The Add Bus Interface dialog box opens (see figure below). A default name is assigned to your bus interface; you can specify your own if you wish.

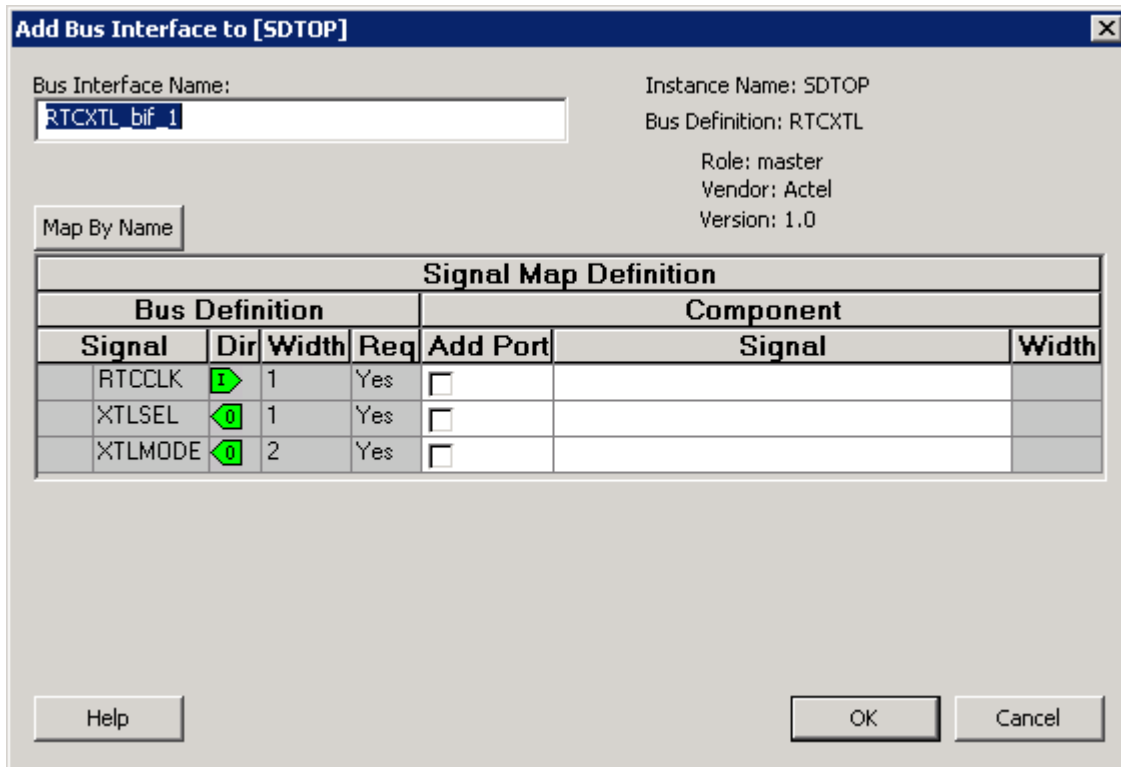

Figure 56 · Add Bus Interface Dialog Box

2. Click **Map by Name** to map the signals automatically. Map By Name attempts to map any similar signal names between the bus definition and pin names on the instance.
3. (Optional) Click the **Add Port** checkbox to add ports to the top-level. If you choose to add ports, the Signal row becomes a text editable field.

## Adding Bus Interfaces to SmartDesign Instances

### **To add a bus interface to your instance:**

1. Select a bus definition from the Bus Definition tab in the [Catalog](#) and drag it onto your instance. The Add Bus Interface dialog box opens (see figure below). A default name is assigned to your bus interface; you can specify your own if you wish.

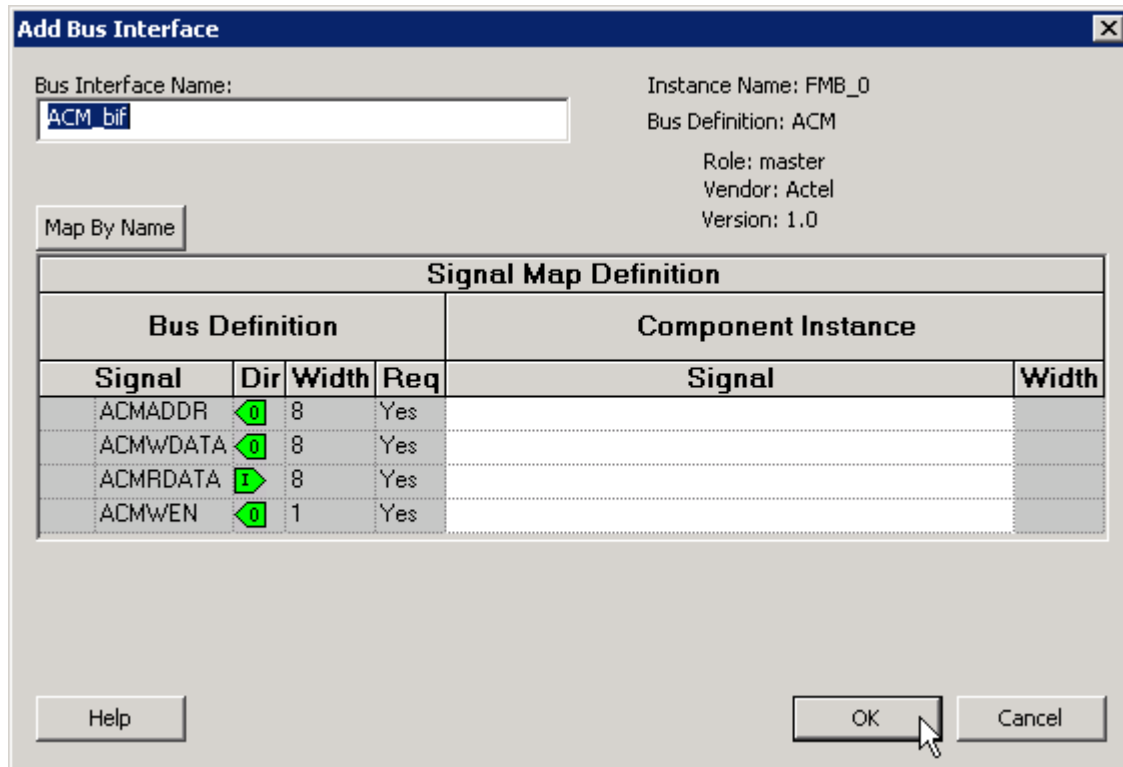

Figure 57 · Add Bus Interface Dialog Box

2. If necessary, enter the configuration parameters.
3. Click **Map by Name** to map the signals automatically. Map By Name attempts to map any similar signal names between the bus definition and pin names on the instance.

## Removing Bus Interfaces from Instances

Only bus interfaces that you explicitly added to an instance can be removed or deleted. Bus interfaces that were instantiated as part of core generation cannot be deleted.

To delete user added bus interfaces, on the Canvas, select the bus interface pin object, right-click, and choose **Delete Bus Interface**; or, in the Grid, select the **Port Name** field, right-click, and choose **Delete Bus Interface**.

## Viewing Bus Interface Properties

### **To view the properties of a bus interface:**

In the Canvas, select the bus interface pin object, right-click, and choose **Properties**. This opens the View Bus Interface dialog box (see figure below).

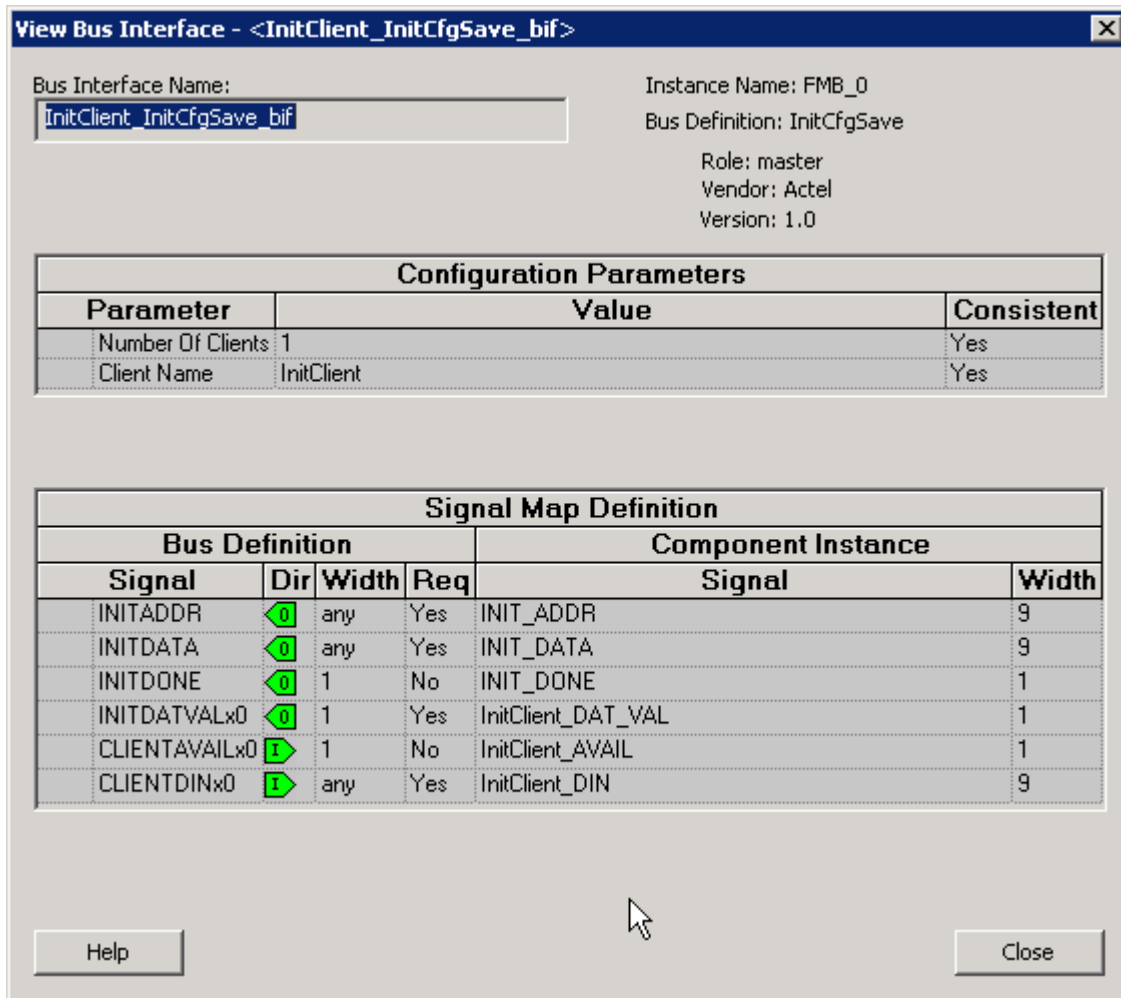

Figure 58 · View Bus Interface Properties Dialog Box

## Bus Interface Details

**Bus Interface Name:** Name of bus interface.

**Instance Name:** Specifies the name of the instance.

**Bus Definition:** Specifies the name of the bus interface.

**Role:** Specifies the bus role (master or slave).

**Vendor:** Specifies the vendor for the bus interface.

**Version:** Specifies the version for the bus interface.

## Configuration Parameters

Certain bus definitions contain user configurable parameters.

**Parameter:** Specifies the parameter name.

**Value:** Specifies the value you define for the parameter.

**Consistent:** Specifies whether a compatible bus interface must have the same value for this bus parameter. If the bus interface has a different value for any parameters that are marked with consistent set to **yes**, this bus interface will not be connectable.

## Signal Map Definition

The signal map of the bus interface specifies the pins on the instance that correspond to the bus definition signals. The bus definition signals are shown on the left, under the **Bus Interface Definition**. This information includes the name, direction, width, and required properties of the signal.

The pins for your instance are shown in the columns under the Component Instance. The signal element is a drop-down list of the pins that can be mapped for that definition signal. Only pins that have the same direction and width requirements will be shown.

If the Req field of the signal definition is Yes, you must map it to a pin on your instance for this bus interface to be considered legal. If it is No, you can leave it unmapped.

If the Width field is *Any* there is no restriction on the width for this definition signal. That means a pin of any width on your instance can be mapped to this signal. During bus interface connection, if the instance pins are of differing widths, the bit connections will start from right to left. For example, if a 16-bit bus is connected to an 8-bit bus, the 8-bit bus will be connected to bits 7 down to 0 of the 16-bit bus. The higher bits will be unmapped and [tied off](#) at generation time.

## Modifying Bus Interface Details

Only bus interfaces that you explicitly added to an instance can be modified. Bus interfaces that were instantiated as part of core generation cannot be modified.

### **To modify the properties of a bus interface:**

1. In the [Canvas](#), select the bus interface pin object, right-click, and choose **Modify Bus Interface** (see figure below).



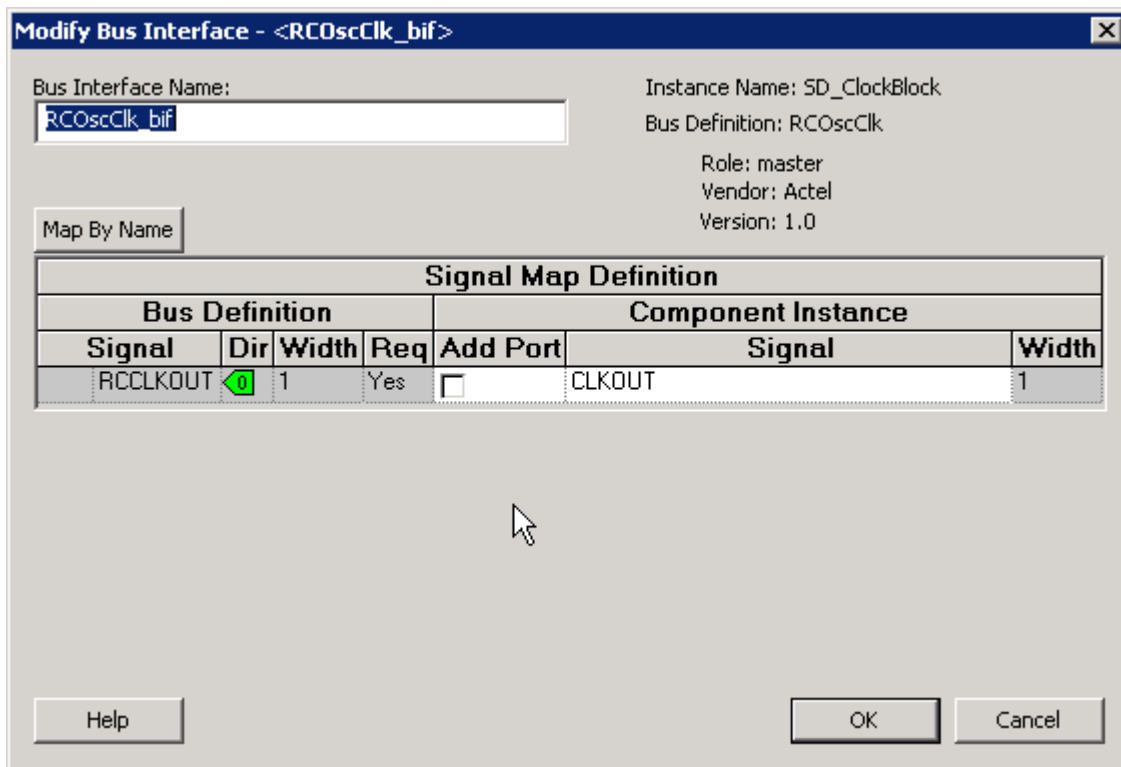

Figure 59 · Modify Bus Interface Dialog Box

2. Modify the bus [interface details](#), [configuration parameters](#), or [signal map definition](#) and click **OK**.

**Map By Name** attempts to map any similar signal names between the bus definition and pin names on the instance.

## Finding Compatible Bus Interfaces

The SmartGuide feature helps you complete your design; when you have a specific bus interface on an instance, you can find a compatible instance, component, or core to connect.

### **To find a compatible bus interface:**

1. In the [Canvas](#), select the bus interface pin object, right-click, and choose **Find Compatible Bus Interface**. This brings up the Find Compatible Bus Interface dialog box, showing the compatible instances, components, or cores that have the bus interface.

SmartGuide searches all the instances in the current SmartDesign for any compatible bus interfaces. SmartGuide also searches through all the configured components in the Libero IDE project for any compatible bus interfaces, then searches through the Cores Catalog for any cores that may potentially contain a compatible bus interface when generated.

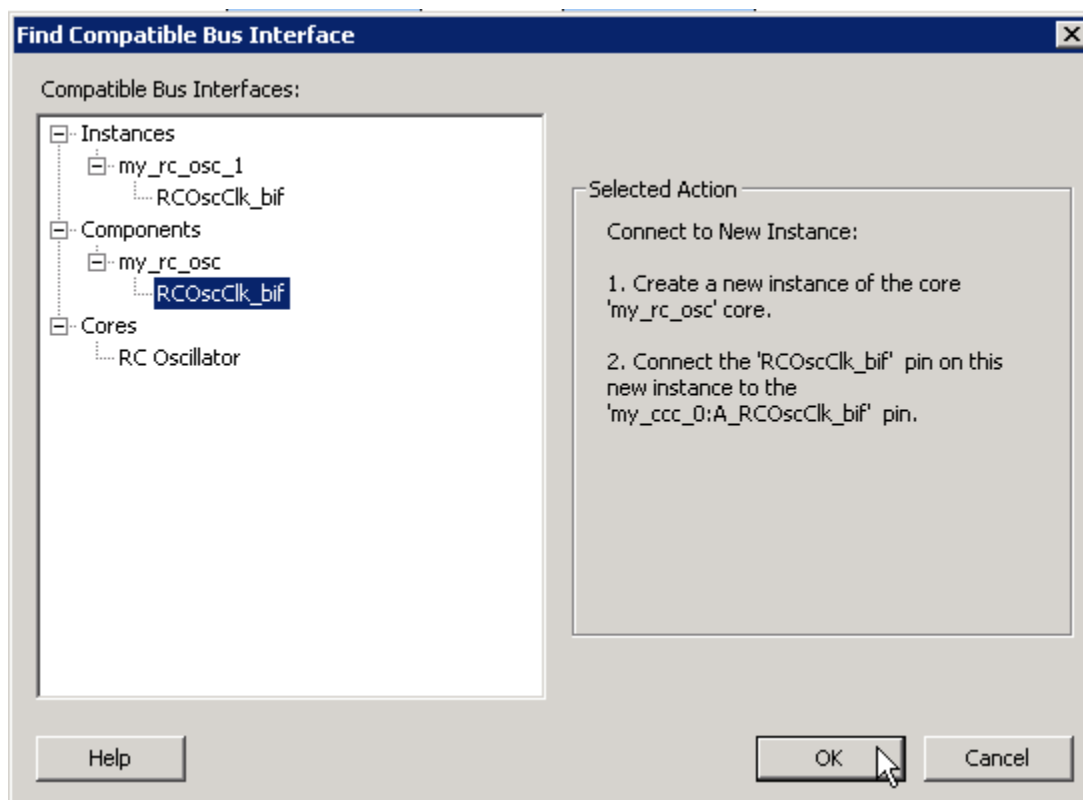

Figure 60 · Find Compatible Bus Interface Dialog Box

2. Select a compatible instance, component or core and click **OK**.
  - Selecting an instance from this list automatically connects that instance to the selected bus interface.
  - Selecting a component from this list automatically instantiates that component into the design and connects it to the selected bus interface.
  - Selecting a core from this list automatically brings up the configurator for that core and enables you to generate a new core. It will then be added to the design and connected. Note that it is possible to configure a core such that no compatible bus interface is generated; you will be given the opportunity to reconfigure the core in this scenario.

## Actel Bus Interfaces

The [Catalog](#) provides the following Actel-specific bus interfaces:

### ExtSeqCtrl

This bus interface defines the set of signals required to interface to the Analog System External Sequence Control. If the Analog System is configured with more than a single procedure, it will export this bus interface. Your own logic would need to connect to this bus interface to properly communicate and control the sequencer.

## RTCXTL

This bus interface represents the hardwired connection needed between the Real Time Counter and the Crystal Oscillator.

## RTCVR

This bus interface represents the hardwired connection needed between the Real Time Counter and the Voltage Regulator Power Supply Monitor.

## InitCfg

This is the initialization and configuration interface that is generated as part of the Flash Memory Builder. Any clients can be initialized from the Flash Memory as long as it can connect to this bus interface. This is for pure initialization clients that do not require save-back to the Flash Memory.

## InitCfgSave

This is the initialization and configuration interface that is generated as part of the Flash Memory Builder. Any client can be initialized or saved-back to the Flash Memory as long as it can connect to this bus interface. This is for clients that require initialization and save-back capabilities to the Flash Memory.

## InitCfgCtrl

This interface is used to initiate the save-back procedure of the Flash Memory.

## InitCfgAnalog

This interface is required between the Flash Memory System and the Analog System core.

## FlashDirect

This bus interface defines the set of signals that are required to interface directly to the Flash Memory. From the Flash Memory, if you add a data storage client, this interface will be exported. Interfacing to this interface enables direct access to the Flash Memory.

## XTLOscClk

This interface represents the Crystal Oscillator clock.

## RCOscClk

This interface represents the RC Oscillator clock.

## DirectCore Bus Interfaces

The Catalog provides the following DirectCore bus interfaces.

### AHB

The AMBA AHB defines the set of signals for a component to connect to an AMBA AHB or AHBLite bus. The bus interface that is defined in the system is a superset of the signals in the AHB and AHBLite protocol. You can use the AHB bus interface in the bus definition catalog to connect your module to an AHB or AHBLite bus.

### APB

The AMBA APB defines the set of signals for a component to connect to an AMBA APB or APB3 bus. The bus interface that is defined in the system is a superset of the signals in the APB and APB3 protocol. You can use the APB bus interface in the bus definition catalog to connect your module to an APB or APB3 bus.

### SysInterface

The SysInterface is the interface used between the CoreMP7 and CoreMP7Bridge cores.

### DBGInterface

This is the set of debug ports on the CoreMP7 core.

### CPInterface

This is the co-processor interface on the CoreMP7 core.

## Exposing Bus Interface Pins

Pins that are contained as part of a bus interface will automatically be filtered out of the display. These ports are considered to be connected and used as part of a bus interface.

However, there are situations where you may wish to use the ports that are part of the bus interface as an individual port, in this situation you can choose to expose the pin from the bus interface.

#### **To expose pins in a Bus Interface:**

1. Select a bus interface port, right-click, and choose **Expose Bus Interface Pins**. The Expose Bus Interface Pin dialog box appears (as shown below).

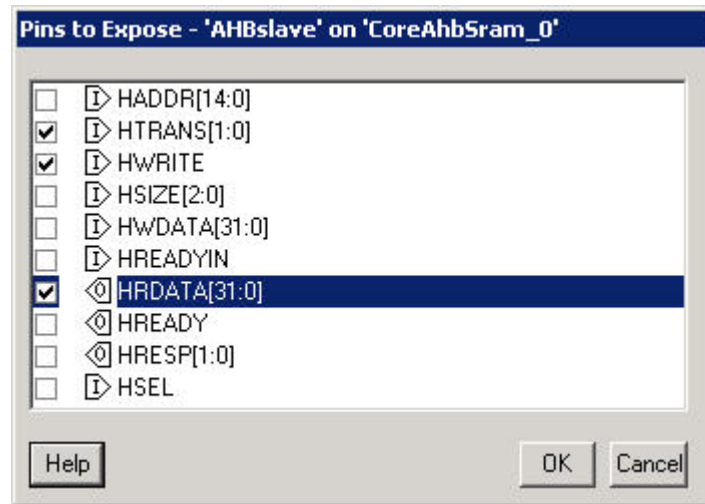

Figure 61 · Expose Driver Pin Dialog Box

2. Click the checkbox associated with the driver pin you want to expose. Once the port is exposed it appears in the Grid and is available for individual connection.

**Note:** Note: If you have already connected the bus interface pin, then you will not be able to expose the non-driver pins. They will be shown grayed out in the dialog. This is to prevent the pin from being driven by two different sources.

To un-expose a driver pin, right-click the exposed port and choose **Hide Bus Interface Pin**.

## Default Tie-offs with Bus Interfaces

Bus definitions can contain default values for each of the defined signals. These default values specify what the signal should be tied to if it is mapped to an unconnected input pin on the instance.

Bus definitions are specified as [required connection vs optional connection](#) that defines the behavior of tie-offs during SmartDesign generation.

**Required bus interfaces** - The signals that are not required to be mapped will be tied off if they are mapped to an unconnected input pin.

**Optional bus interfaces** - All signals will be tied off if they are mapped to an unconnected input pin.

## Tying Off (Disabling) Unused Bus Interfaces

Tying off (disabling) a bus interface sets all the input signals of the bus interface to the default value.

To tie off a bus interface, right-click the bus interface and select Tie Off.

This is useful if your core includes a bus interface you plan to use at a later time. You can tie off the bus interface and it will be disabled in your design until you manually set one of the inputs.

Some bus interfaces are required; you cannot tie off a bus interface that is required. For example, the Crystal Oscillator to RTC (RTCXTL) bus interface is a silicon interface and must be connected.

To enable your pin, right-click the pin and choose **Clear Attribute**.

## Required vs. Optional Bus Interfaces

A required bus interface means that it must be connected for the design to be considered legal. These are typically used to designate the silicon interconnects that must be present between certain cores. For example, when using the Real Time Counter in a Fusion design you must also connect it up to a Crystal Oscillator core.

An optional bus interface means that your design is still considered legal if it is left unconnected. However, it may not functionally behave correctly.

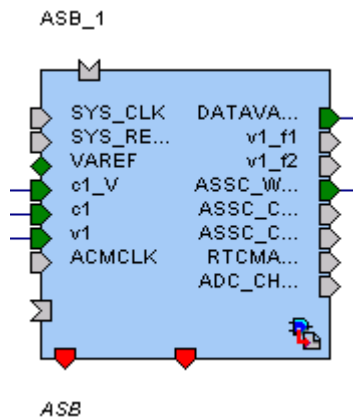

Figure 62 · Required Unconnected, Optional Unconnected, and Connected Bus Interfaces

### See Also

[Canvas icons](#)

## Promoting Bus Interfaces to Top-level

To automatically connect a bus interface to a top-level port, select the bus interface, right-click, and choose **Promote To Top Level**.

This automatically creates a top-level bus interface port of that name and connects the selected port to it. If a bus interface port name already exists, a choice is given to either connect to the existing bus interface port or to create a new bus interface port with a name <port name>\_<i> where i = 1...n.

The signals that comprise the bus interface are also promoted.

Promoting a bus interface is a shortcut for creating a top-level port and connecting it to an instance pin.

# Incremental Design

## Reconfiguring a Component

### **To reconfigure a component used in a SmartDesign:**

- In the Canvas, select the instance and double-click the instance to bring up the appropriate configurator, or the HDL editor; or select the instance, right-click it, and choose **Configure Component**.
- Select the component in the [Hierarchy tab](#), [Files tab](#) or [Find output window](#), and from the right-click menu select **Open Component**.

When the configurator is launched from the canvas, you cannot change the name of the component.

### **See Also**

[Design state management](#)

[Replacing components](#)

## Fixing an Out-of-date Instance

Any changes made to the component will be reflected in the instance with an exclamation mark  when you update the definition for the instance. An instance may be out-of-date with respect to its component for the following reasons:

- If the component interface (ports) is different – after reconfiguration - from that of the instance
- If the component has been removed from the project
- If the component has been moved to a different VHDL library
- If the SmartDesign has just been imported

You can fix an out-of-date instance by:

- Replacing the component with a new component (as shown in the figure below)
- Updating with the latest component

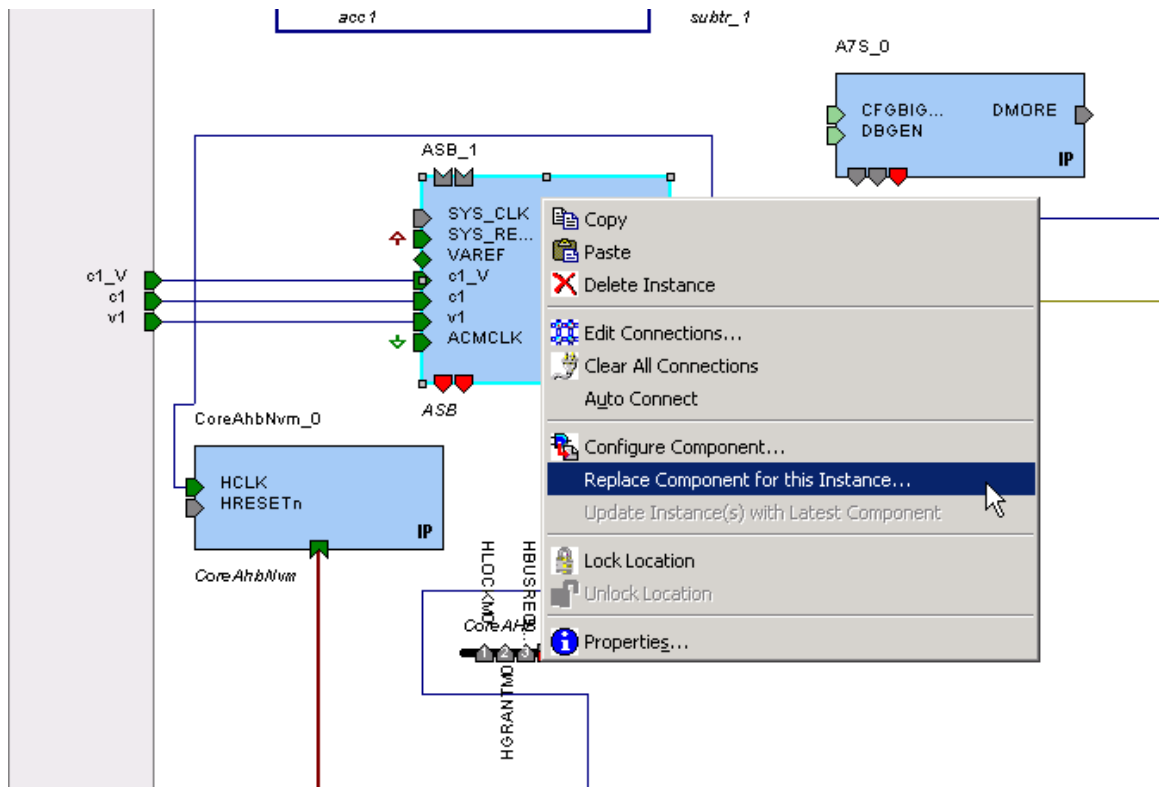

Figure 63 · Right-Click Menu - Replace Component for this Instance

### See Also

- [Design state management](#)
- [Reconfiguring components](#)
- [Replacing components](#)

## Replacing Components

Components of an instance on the Canvas can be replaced with another component and maintain connections to all ports with the same name.

### To replace a component in your design:

1. Select the component on the Canvas, right-click, and choose **Replace component for this Instance**. The Replace Component dialog box appears (see figure below).



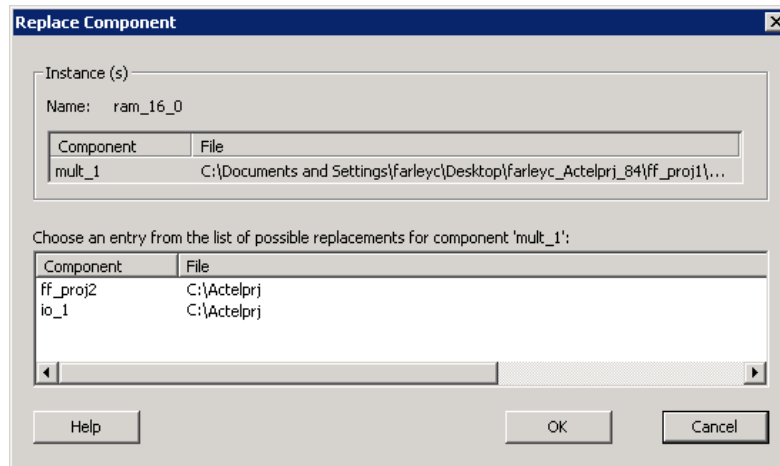

Figure 64 · Replace Component Dialog Box

2. Select the component you want to replace it with and click **OK**.

## Design State Management

When any component with instances in a SmartDesign design is changed, all instances of that component detect the change.

If the change only affects the memory content, then your changes do not affect the component's behavior or port interface and your SmartDesign design does not need to be updated.

If the change affects the behavior of the instantiated component, but the change does not affect the component's port interface, then your design must be resynthesized, but the SmartDesign design does not need to be updated.

If the port interface of the instantiated component is changed, then you must reconcile the new definition for all instances of the component and resolve any mismatches. If a port is deleted, SmartDesign will remove that port and clear all the connections to that port when you reconcile all instances. If a new port is added to the component, instances of that component will contain the new port when you reconcile all instances.

The affected instances are identified in your SmartDesign design in the Grid and the Canvas with an exclamation point. Right-click the instance and choose **Update With Latest Component**.

**Note:** Note: For HDL modules that are instantiated into a SmartDesign design, if the modification causes syntax errors, SmartDesign does not detect the port changes. The changes will be recognized when the syntax errors are resolved.

### Changing memory content

For certain cores such as Analog System Builder, Flash Memory, or FlexRAM it is possible to change the configuration such that only the memory content used for programming is altered. In this case Project Manager (IDE) will only invalidate your programming file, but your synthesis, compile, and place-and-route results will remain valid.

When you modify the memory content of a core such as Analog System Builder or RAM with Initialization that is used by a Flash Memory core, the Flash Memory core indicates that one of its dependent components has changed and that it needs to be regenerated. This indication will be shown in the Hierarchy or Files Tab .

In these cases, the Project Manager indicates that your programming file is out of date but your synthesis and place-and-route remain valid. You only need to regenerate your programming file in FlashPoint.

If any core is regenerated where the HDL file is not modified, the Project Manager design state will not invalidate your Synthesis and/or Place-and-Route results. Some specific cores are listed below.

**RAM with Initialization core** - You can modify the memory content without invalidating synthesis.

**Analog System Builder core** - You can modify the following without invalidating synthesis:

- Existing flag settings: threshold levels, assertion/de-assertion counts, OVER/UNDER type
- Modifying sequence order or adding sequence operations
- Changing acquisition times
- Resistor Value for the Current Monitor
- RTC time settings
- Gate Driver source current

**Flash Memory System Builder core** - You can modify the following without invalidating synthesis:

- Modifying memory file or memory content for clients
- JTAG protection for Init Clients

## Design Rules Check

To run the Design Rules Check, from the **SmartDesign** menu, choose **Check Design Rules**.

SmartDesign displays your design rule violations in the Design Rules Check grid (similar to the [Grid](#)), but with additional fields available: Type, Message and Details.

- **Type** displays an icon to indicate if the message is an error or a warning (as shown in the figure below). Error messages are shown with a small red stop sign . and warning messages with a yellow exclamation point. 
- **Message** identifies the specific error/warning (see list below)
- **Details** provides information related to the Message

Type	Message	Details	Instance	Port Name	Slice	Attribute
Unused Instance	Unused Instance VRBLK_0	VRBLK_0	VRBLK_0			
Floating Driver	Floating output bus pin ASB_0:ADC_CH...	ASB_0	ASB_0	ADC_CHNUMBER	[4:0]	
	Floating output bus pin ram_reader_0:av...	ram_reader_0	ram_reader_0	avgdata	[11:0]	
	Floating output bus pin ram_reader_0:ra...	ram_reader_0	ram_reader_0	ramaddr	[9:0]	
	Floating output bus pin RAM_SAVE_0:D...	RAM_SAVE_0	RAM_SAVE_0	DOUTA	[31:0]	
	Floating output bus pin RAM_SAVE_0:D...	RAM_SAVE_0	RAM_SAVE_0	DOUTB	[31:0]	
	Floating output pin ASB_0:ASSC_CHLATD	ASB_0	ASB_0	ASSC_CHLATD		
	Floating output pin ASB_0:ASSC_CHSAT	ASB_0	ASB_0	ASSC_CHSAT		
	Floating output pin ASB_0:ASSC_WAIT	ASB_0	ASB_0	ASSC_WAIT		
	Floating output pin ASB_0:DATAVALID	ASB_0	ASB_0	DATAVALID		
	Floating output pin VRBLK_0:FPGAGOOD	VRBLK_0	VRBLK_0	FPGAGOOD		
	Floating output pin VRBLK_0:PUCORE	VRBLK_0	VRBLK_0	PUCORE		
Unconnected Bus I...	Unconnected bus interface pin ASB_0:E...	ASB_0	ASB_0	ExtSeqCtrl_bif		

Figure 65 · Design Rules Check Results Grid

**Unused Instance** - You must remove this instance or connect at least one output pin to the rest of the design.

**Out-of-date Instance** - You must update the instance to reflect a change in the component referenced by this instance; see [Fixing an out-of-date instance](#).

**Undriven Pin** - To correct the error you must connect the pin to a driver or change the state, i.e. tie low (GND) or tie high (VCC).

**Floating Driver** - You can mark the pin unused if it is not going to be used in the current design. Pins marked unused are ignored by the Design Rules Check.

**Unconnected Bus Interface** - You must connect this bus interface to a compatible port because it is required connection.

**Required Bus Interface Connection** - You must connect this bus interface before you can generate the design. These are typically silicon connection rules.

**Exceeded Allowable Instances for Core** - Some IP cores can only be instantiated a certain number of times for legal design. For example, there can only be one CortexM1 or CoreMP7 in a design because of silicon rules. You must remove the extra instances.

**Incompatible Family Configuration** - The instance is not configured to work with this project's Family setting. Either it is not supported by this family or you need to re-instantiate the core.

**Incompatible Die Configuration** - The instance is not configured to work with this project's Die setting. Either it is not supported or you need to reconfigure the Die configuration.

**Incompatible 'Debug' Configuration** - You must ensure your CoreMP7 and CoreMP7Bridge have the same 'Debug' configuration. Reconfigure your instances so they are the same.

**No RTL License, No Obfuscated License, No Evaluation License** - You do not have the proper license to generate this core. [Contact Actel](#) to obtain the necessary license.

**No Top level Ports** - There are no ports on the top level. To auto-connect top-level ports, right-click the Canvas and choose Auto-connect

## Generating a SmartDesign Component

Before your SmartDesign component can be used by downstream processes, such as synthesis and simulation, you must generate it.

To generate a SmartDesign component, from the **SmartDesign** menu, choose **Generate** or click .

This will generate a HDL file in the directory <libero\_project>/components/<library>/<yourdesign>.

**Note:** Note: The generated HDL file will be deleted when your SmartDesign design is modified and saved to ensure synchronization between your SmartDesign component and its generated HDL file.

Generating a SmartDesign component may fail if there are any DRC errors. DRC errors must be corrected before you generate your SmartDesign design.

## Synthesizing the SmartDesign Component

Synthesizing a SmartDesign component using the Project Manager is the same as any other design component. See the [Synthesis help](#) for more information on using the Project Manager to synthesize your design.

A SmartDesign component must be generated before it can be synthesized.

**Note:** Note: Once a component is set as root in the Project Manger Hierarchy, it can be synthesized.

## Simulating the SmartDesign Component

Simulating a SmartDesign component is identical to simulating any other element in the Libero IDE Project Manager Hierarchy (in the project using ModelSIM AE). See the [ModelSIM AE with Libero IDE help](#) and the ModelSIM help for more information.

### Simulating IPs







Some IPs are packaged with their own testbenches and verification suites. You can run these tests if you want to ensure the IP is working properly.

#### **To simulate an individual DirectCore IP:**



1. Generate your design.
2. In the Hierarchy, change the Show drop-down menu to Modules. This switches all the components to their module representation.
3. Select the IP that you wish to simulate, right-click and choose **Set As Root**. You may have to expand the Hierarchy to view the IP module you wish to simulate.
4. Click the Simulation icon in the Project Flow window to run simulation.

## Reference

### SmartDesign Menu

Command	Icon	Function
Show Canvas View		Displays the Canvas
Show Grid View		Displays the Grid
Show Schematic View		Displays the Schematic Viewer
Show Memory Map / Data Sheet		Displays the datasheet for the design
Check Design Rules		Runs the Design Rules Check
Generate Design		Generates your SmartDesign component
Auto Connect		Auto-connects instances
Add Port		Adds a port to the top of the SmartDesign component

### Canvas Menu

Command	Icon	Function
Auto-Arrange Instances		Auto-arranges the Canvas location of the instances on your Canvas; note that the Canvas location of the instances is a representation and not the actual layout.
Auto-Arrange Connections		Auto-arranges the Canvas location of the connections on your Canvas; note that the Canvas location of the instances is a representation and not the actual layout





Command	Icon	Function
Nets		Shows/hides the nets on the Canvas
Ruler		Shows/hides the ruler at the edges of your Canvas
Grid Points		Shows/hides grid points on your Canvas
Page Bounds		Shows/hides the page boundaries on your Canvas

## Grid Menu

Command	Function
Hide All Connected Ports	Hides all connected ports in the current grid
Fit All Columns to Data	Fits the column size to the data in the column
Reset Instance [or Net] View to Default	Resets the grid layout for the current grid
Show All Rows	Shows all rows in the Display Panel
Show All Instance Columns	Shows all instance columns in the Connection Panel
Show All Rows and Columns	Shows all rows and columns in the Display Panel
Attribute Column	Shows/hides the Attribute column in the Connection Panel
Top Level Column	Shows/hides the Top Level column in the Connection Panel
Fields	Shows/hides the selected field in the Display Panel

## Schematic Menu

Command	Icon	Function
---------	------	----------

Command	Icon	Function
Go To First Page		Goes to first page in Schematic View (when using page splitting)
Go To Previous Page		Goes to previous page in Schematic View (when using page splitting)
Go To Next Page		Goes to next page in Schematic View (when using page splitting)
Go To Last Page		Goes to last page in Schematic View (when using page splitting)
Allow Page Splitting		Allows page splitting; useful when you have a large schematic
Fit to Page		Fits the content to a single page

## SmartDesign Glossary

Term	Description
BIF	Abbreviation for bus interface.
bus	An array of scalar ports or pins, where all scalars have a common base name and have unique indexes in the bus.
Bus Definition	Defines the signals that comprise a bus interface. Includes which signals are present on a master, slave, or system interface, signal direction, width, default value, etc. A bus definition is not specific to a logic or design component but is a type or protocol.
Bus Interface	Logical grouping of ports or pins that represent a single functional purpose. May contain both input and output, scalars or busses. A bus interface is a specific mapping of a bus definition onto a component instance.
Bus Interface Net	A connection between 2 or more compatible bus interfaces.
Canvas	Block diagram, connections represent data flow; enables you to connect instances of components in your design.

Term	Description
Component	<p>Design element with a specific functionality that is used as a building block to create a SmartDesign core.</p> <p>A component can be an HDL module, non-IP core generated from the Catalog, SmartDesign core, Designer Block, CoreConsole core, or IP core. When you add a component to your design, SmartDesign creates a specific instance of that component.</p>
Component Declaration	VHDL construct that refers to a specific component.
Component Port	An individual port on a component definition.
Grid	Manual connection tool in SmartDesign.
Driver	A driver is the origin of a signal on a net. The input and slave BIF ports of the top-level or the output and Master BIF ports from instances are drivers.
Instance	<p>A specific reference to a component/module that you have added to your design.</p> <p>You may have multiple instances of a single component in your design. For each specific instance, you usually will have custom connections that differ from other instances of the same component.</p>
Master Bus Interface	The bus interface that initiates a transaction (such as a read or write) on a bus.
Net	Connection between individual pins. Each net contains a single output pin and one or more input pins, or one or more bi-directional pins. Pins on the net must have the same width.
PAD	The property of a port that must be connected to a design's top level port. PAD ports will eventually be assigned to a package pin. In SmartDesign, these ports are automatically promoted to the top-level and cannot be modified.
Pin	An individual port on a specific instance of a component.
Port	An individual connection point on a component or instance that allows for an



Term	Description
	<p>electrical signal to be received or sent. A port has a direction (input, output, bi-directional) and may be referred to as a 'scalar port' to indicate that only a single unit-level signal is involved. In contrast, a bus interface on an instance may be considered as a non-scalar, composite port.</p> <p>A component port is defined on a component and an instance port (also known as a 'pin') is part of a component instance.</p>
Signal	A net or the electrical message carried on a net.
Slave Bus Interface	Bus interface that terminates a transaction initiated by a master interface.
System Bus Interface	Interface that is neither master nor slave; enables specialized connections to a bus.
Top Level Port	An external interface connection to a component/module. Scalar if a 1-bit port, bus if a multiple-bit port.





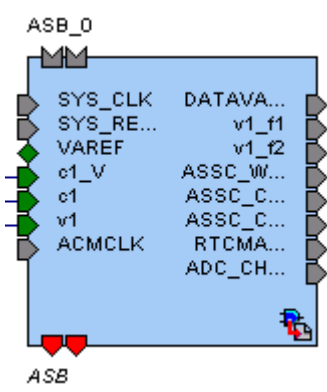

## Canvas Icons

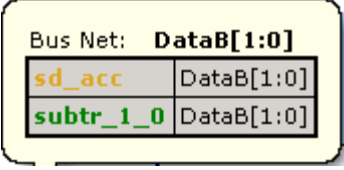

Canvas icons are listed below.

Hover your pointer over any icon in the SmartDesign Canvas view to display details.

Icon	Description
	<p>Representation of an instance in your design. An instance is a component that has been added to your SmartDesign component. The name of the instance appears at the top and the name of the generic component at the bottom.</p> <p>The instance type is indicated by an icon inside the instance. There are specific icons for instances from SmartDesign, CoreConsole, HDL, and ViewDraw. The instance icon at left indicates an Actel core.</p>

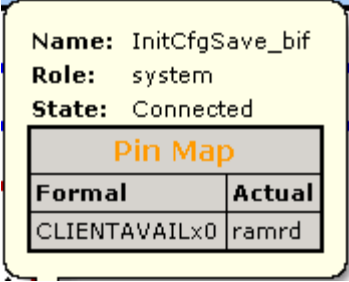

Icon	Description
	<p>Bus Net details.</p>
	<p>Master bus interface icon. A master is a bus interface that initiates a transaction on a bus interface net.</p> <p>An unconnected master BIF with REQUIRED connection is red (shown at left).</p> <p>A master BIF with unconnected OPTIONAL connection is gray.</p>
	<p>Master BIF details, showing name, role, and state.</p> <p>The Pin Map shows the Formal name of the pin assigned by the component (in this example, RCCLKOUT) and the Actual, or representative name assigned by the user (CLKOUT).</p>
	<p>Slave BIF (shown at left).</p> <p>Unconnected slave icons with REQUIRED connections are red.</p> <p>Unconnected slave icons with OPTIONAL connections are gray.</p>
	<p>Slave BIF details, showing name, role, and state.</p> <p>The Pin Map shows the Formal name of the pin assigned by the component (in this example, RCCLKOUT) and the Actual, or representative name assigned by the user (CLKA).</p>
	<p>Master-slave bus interface connection</p>
	<p>Master-slave bus interface connection details.</p>

Icon	Description
	<p><a href="#">Groups of pins</a> in an instance.</p> <p>Fully connected groups are solid green.</p> <p>Partially connected groups are gray with a green outline.</p> <p>Unconnected groups (no connections) are gray with a black outline.</p>
	<p>A system BIF is the bus interface that does not have a simple input/output relationship on both master/slave.</p> <p>This could include signals that only drive the master interface, or only drive the slave interface, or drive both the master and slave interfaces.</p>
	<p>System BIF details, showing name, role, and state.</p> <p>The Pin Map shows the Formal name of the pin assigned by the component (in this example, CLIENTAVAILx0), and the Actual name assigned by the user (in this example: ramrd).</p>



## Grid - Display Panel Icons



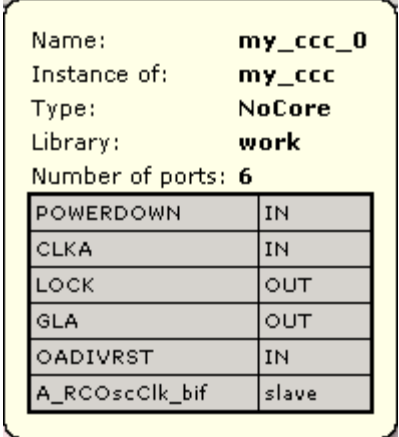

Icon	Description
------	-------------

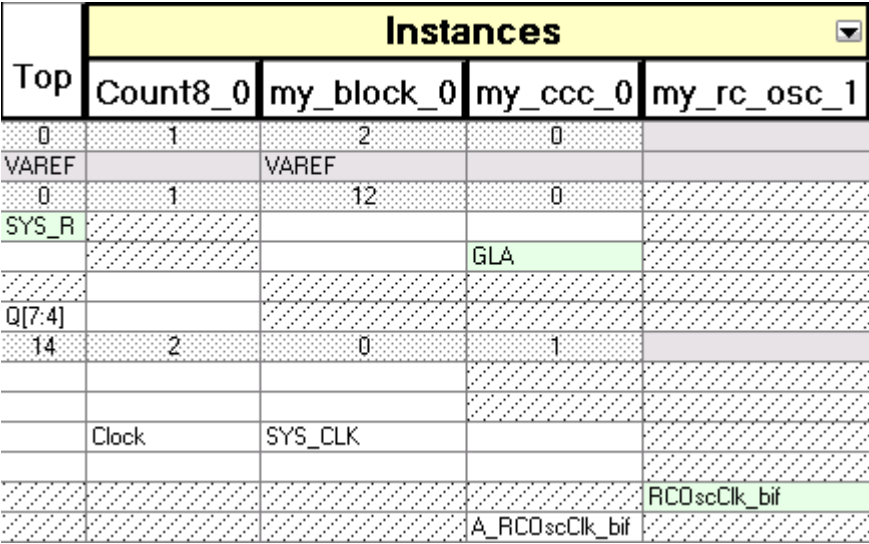
Icon	Description
	<p>Display panel (default Instance-Instance view). Note the +/- next to the instances to expand and contract the lists.</p> <p>You can click and drag an edge to resize the columns in the Display panel.</p> <p>Click and drag the column headings (Instance, Port Name, Slice, etc.) to change the order of the columns.</p> <p>Right-click the column headings to modify the fields (show/hide Instance, Port, etc.)</p>
	<p><a href="#">Filter button</a></p>
	<p>Output icon (Port field). Shows that the port is a connected (green) output (letter O).</p>
	<p>Input icon (Port field). Shows that the port is a connected (green) input (letter I).</p>
	<p>INOUT icon (Port field). Shows that the port is a connected INOUT port. Unconnected INOUT ports are white.</p>
	<p>Disconnected (white) output icon</p>
	<p>Disconnected input icon</p>
	<p>Master icon, connected</p>
	<p>Master icon, unconnected</p>
	<p>Slave icon, connected</p>
	<p>Slave icon, unconnected</p>

Icon	Description												
 <p>Name: <b>my_ccc_0</b>  Instance of: <b>my_ccc</b>  Type: <b>NoCore</b>  Library: <b>work</b>  Number of ports: <b>6</b></p> <table border="1" data-bbox="355 552 699 768"> <tr><td>POWERDOWN</td><td>IN</td></tr> <tr><td>CLKA</td><td>IN</td></tr> <tr><td>LOCK</td><td>OUT</td></tr> <tr><td>GLA</td><td>OUT</td></tr> <tr><td>OADIVRST</td><td>IN</td></tr> <tr><td>A_RC0scClk_bif</td><td>slave</td></tr> </table>	POWERDOWN	IN	CLKA	IN	LOCK	OUT	GLA	OUT	OADIVRST	IN	A_RC0scClk_bif	slave	<p>Display panel instance details.</p> <p><b>Name</b> is the name of your component; the default name for components is &lt;instance&gt;_0.</p> <p><b>Instance of</b> specifies the component that was used to create the instance.</p> <p><b>Type</b> shows the origin of the component, such as Design Block if the component was created from the the Catalog, or IP if the core was created by CoreConsole.</p> <p><b>Library</b> is the library location of the core.</p>
POWERDOWN	IN												
CLKA	IN												
LOCK	OUT												
GLA	OUT												
OADIVRST	IN												
A_RC0scClk_bif	slave												

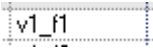
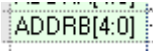
## Grid - Connection Panel Icons

Icon	Description
 <p>The icon shows a connection grid titled "Instances" with a dropdown arrow. The grid has columns for instances: Count8_0, my_block_0, my_ccc_0, and my_rc_osc_1. It displays various connections between ports like VAREF, SYS_R, Q[7:4], Clock, and A_RC0scClk_bif.</p>	<p>Connection panel (Instance-Instance view). This default view of this panel shows your top level, all instances, and their corresponding connections to instances in the <a href="#">Display panel</a>.</p> <p>Use the <a href="#">filter</a> button  to show/hide your instances. Intersections between identical instances are grayed out.</p> <p>Also, inputs may only be connected to outputs, outputs only connected to inputs. INOUT ports may be connected to inputs or outputs.</p>

Icon	Description
	<p>White, empty cells indicate that a connection is possible, but not active.</p>
	<p>White cells with text indicate that the cell is connected and a non-driver.</p>
	<p>Light green cells indicate that the cell is connected and is a driver.</p>
	<p>Gray cells are read-only and indicate that the connection is exclusively reserved for pads.</p>
	<p>Blue dotted cells indicate that there are multiple connections at that intersection - the number in the cell shows how many connections there are; click the cell to view the connections.</p>
	<p>Black dotted cells indicate that multiple connections are possible - the number in the cell indicates how many connections are available; expand the instance in the Display panel to show more connections.</p>
	<p>Diagonal hatch cells indicate no legal connections are possible</p>

Icon				Description																																																																		
<input checked="" type="radio"/> Instance-Instance View <input type="radio"/> Net-Instance View																																																																						
<table border="1"> <thead> <tr> <th>Instance</th> <th>Port</th> <th>Slice</th> <th>Top</th> <th>Instance</th> </tr> </thead> <tbody> <tr> <td>+</td> <td>+</td> <td>+</td> <td>Top</td> <td>my_ccc_0</td> </tr> <tr> <td></td> <td>Aclr</td> <td></td> <td>0</td> <td>0</td> </tr> <tr> <td></td> <td>Clock</td> <td></td> <td>SYS_R</td> <td></td> </tr> <tr> <td>-</td> <td>Q</td> <td>[7:0]</td> <td colspan="2">*Show Only Unconnected</td> </tr> <tr> <td></td> <td></td> <td>[7:4]</td> <td colspan="2">GLA</td> </tr> <tr> <td></td> <td>LOCK</td> <td></td> <td colspan="2">LOCK</td> </tr> <tr> <td>+</td> <td>A_RC0scClk_bi</td> <td></td> <td colspan="2"></td> </tr> <tr> <td></td> <td>GLA</td> <td></td> <td colspan="2"></td> </tr> <tr> <td></td> <td>LOCK</td> <td></td> <td colspan="2"></td> </tr> <tr> <td>-</td> <td>OADIVRST</td> <td></td> <td colspan="2"></td> </tr> <tr> <td></td> <td>POWERDOWN</td> <td></td> <td colspan="2"></td> </tr> <tr> <td></td> <td>RC0scClk_bif</td> <td></td> <td></td> <td>A_RC0scClk_bif</td> </tr> </tbody> </table>				Instance	Port	Slice	Top	Instance	+	+	+	Top	my_ccc_0		Aclr		0	0		Clock		SYS_R		-	Q	[7:0]	*Show Only Unconnected				[7:4]	GLA			LOCK		LOCK		+	A_RC0scClk_bi					GLA					LOCK				-	OADIVRST					POWERDOWN					RC0scClk_bif			A_RC0scClk_bif	<p>List of ports available to connect. The intersection of an instance in the Display panel and an instance in the Connection panel enables a drop-down menu.</p> <p>Select the pin you want to use to connect the two instances from the drop-down menu.</p> <p>Icons in the drop-down menu represent whether the connection is a connected input, output, master, or slave. See the <a href="#">Display panel icon list</a> for more information.</p>	
Instance	Port	Slice	Top	Instance																																																																		
+	+	+	Top	my_ccc_0																																																																		
	Aclr		0	0																																																																		
	Clock		SYS_R																																																																			
-	Q	[7:0]	*Show Only Unconnected																																																																			
		[7:4]	GLA																																																																			
	LOCK		LOCK																																																																			
+	A_RC0scClk_bi																																																																					
	GLA																																																																					
	LOCK																																																																					
-	OADIVRST																																																																					
	POWERDOWN																																																																					
	RC0scClk_bif			A_RC0scClk_bif																																																																		

## Schematic Symbols

Icon	Description
	Schematic input icon
	Schematic output icon
	Schematic inout icon
	Schematic input icon (multiple addresses)
	Schematic connection icon
	Schematic connection icon (multiple connections)



Icon	Description
	<p>Schematic inverter icon; hover your mouse over the inverter symbol in the schematic view for more information on the state of your inverter. An inverter symbol does not necessarily indicate that all your pins are inverted.</p>

## Using the HDL Editor

The HDL Editor is a text editor designed for editing HDL source files. In addition to regular editing features, the editor provides a [syntax checker](#).

You can have multiple files open at one time in the HDL Editor workspace. Click the tabs to move between files.

**CoreConsole only:** If you use the template created by CoreConsole to instantiate the top level of the CoreConsole project, you must create a new HDL source file and copy the content of the template. If you do not, Libero IDE overwrites the file if you re-import a CoreConsole project.

### Editing

Editing functions are available in the **Edit** menu. Available functions include cut, copy, paste, find, and replace. These features are also available in the toolbar.

### Saving

You must save your file to add it to your Libero IDE project. Select **Save** in the **File** menu, or click the **Save** icon in the toolbar.

### Printing

**Print** and **Print Preview** functions are available from the **File** menu and the toolbar.

**Note:** Note: To avoid conflicts between changes made in your HDL files, Actel recommends that you use one editor for all of your HDL edits.

## Creating New HDL Files

### To create an HDL file:

1. Open your project.
2. From the **File** menu, choose **New**.
3. Click **VHDL** and type a file name in the Name field. Click **OK**. (Do not enter a file extension; Libero adds one for you.) The HDL Editor workspace opens.
4. After creating your HDL file, save your file to the project by selecting **Save** from the **File** menu. Your HDL file is saved to your project and shown in the Files tab.

## Opening an HDL Source File

### **To open an HDL source file:**

1. From the **File** menu, choose **New**.
2. From **Files of Type**, select **HDL File (\*.vhd, \*.vhdl)**.
3. In **Look in**, navigate to the HDL file directory.
4. Select your file and click **Open**. Libero IDE opens your file in the HDL Editor.

## Importing HDL Source Files

Import your HDL file into your project just as you would any source file.

### **To import an HDL source file:**

1. From the **File** menu, choose **Import Files**.
2. In **Files of type**, select the file type.
3. In **Look in**, navigate to the drive/folder that contains the file.
4. Select the file to import and click **Open**.

## HDL Syntax Checker

After you are done [creating your HDL file](#), use the HDL Syntax Checker to help validate an HDL file after editing the HDL code.

### **To run the syntax checker:**

1. In the **Libero IDE Files** tab, right-click an HDL file and choose **Check HDL File**.
2. The syntax checker parses the selected HDL file and looks for typographical mistakes and syntactical errors. Warning and error messages for the HDL file appear in the Libero IDE Log Window.

## Commenting Text

You can comment text as you type in the HDL Editor, or you can comment out blocks of text by selecting a group of text and applying the Comment command.

### **To comment or uncomment out text:**

1. Type your text.
2. Select the text.
3. From the **Edit** menu or right-click menu, choose **CommentOut** or **Uncomment**.

## Using Design Block Cores from the Catalog - HDL Entry

Use cores to:

- Create high-level modules, such as counters, multiplexers, multipliers, etc. that are optimized for Actel FPGAs.
- Create system-level building blocks, such as filters, FIFOs, and memories.

These can be instantiated into your schematic, Verilog design, or HDL design.

#### **To use Design Blocks with your HDL design:**

1. From the Libero IDE **File** menu, choose **New**.
2. In the **New File** dialog box, select the core, type a name, and click **OK**. The core configurator opens.
3. Select your core type. The appropriate options appear. Select a tab and fill in the fields. Click **Generate**.
4. In the **Save As** dialog box, leave the default selections and click **Save**. The file is added to your Libero IDE project; it is shown in the Hierarchy tab.
5. Instantiate the module in your HDL design.

## ViewDraw AE

ViewDraw AE is a special version of ViewDraw. Use it for schematic entry with Libero IDE.

**CoreConsole only:** If you use the template created by CoreConsole to instantiate the top level of the CoreConsole project, you must create a new HDL source file and copy the content of the template. If you do not, Libero IDE overwrites the file if you re-import a CoreConsole project.

## ViewDraw for Actel Schematics Guidelines

### Adding and Removing Ports from an Existing Schematic

You may wish to add or remove ports from an existing schematic. To do so:

1. From the Libero Project Manager, right-click the symbol and select **Delete from Disk and Project**.
2. In ViewDraw, open your schematic and select Add/remove ports.
3. Click Save and Check.
4. Re-create the symbol from within the Libero Project Manager.
5. Update the schematics, instantiating the modified symbol.

### Naming Conventions

- Project names must be less than 8 characters. For example: my\_top
- Do not use spaces, especially in:
  - Project names
  - Instance names
  - Net names

- Port names
  - Schematic names
  - Stimulus file names
  - HDL names
- Do not use any special characters in any of your naming, such as: ~ ! @ # \$ % ^ & \* ( ) = + { } | \ / < > ? ` ‘ “ ” , . or spaces.
  - The tool does not support the “inverted” net property.
  - If you want to rip out scalar bits from a bus, use [] for scalar bit naming. For example, Bus[15], Bus[14], ..., Bus[0]. If a bus DATA[15:0] is declared in the schematic then you can also use net names DATA5, DATA10 etc. to rip the DATA bus. If net DATA5 is unrelated to the DATA bus then you need to add a letter at the end of the net name, e.g. DATA5N.
  - Do not use numbers at the beginning or the end of any names.  
Scalar bit Bus1[15] of Bus1[15:0] can be confused with Scalar bit Bus11[5] of Bus11[15:0] during netlist generation.
  - If you want to use numbers to distinguish related nets, use numbers followed by letters at the end, for example: NET1N, or Bus1A[15:0].
  - Do not use naming “Bus[0:3][0:3]” to implement scalar bits. The second bus dimension is not supported. Instead use: Bus[00], Bus[01]..., Bus[10], Bus[11]....
  - Multi-dimensional busses are not supported. For example, do not use naming "Bus[0:3][0:3]" in ViewDraw AE.
  - Do not name any component with the same name as [Actel library components](#).

## Finding an Inverted Signal in a Schematic

When looking for an inverted signal, use '~signal\_name' instead of 'signal\_name', since in schematic and wir files, inverted signals are saved as '~signal\_name'. Use the menu option Edit > Select to find the signal.

## Using Connectors and I/O Pads

- Use hierarchy connectors in any schematic design for any external ports and any ports of sub-modules.
- You can insert I/O pads automatically by running Synthesis or Optimize & Insert Pads from Libero IDE. For schematic designs, which only use Actel primitives (no HDL blocks), you can manually insert all I/O pads. This is in case you do not want to go through the synthesis flow.

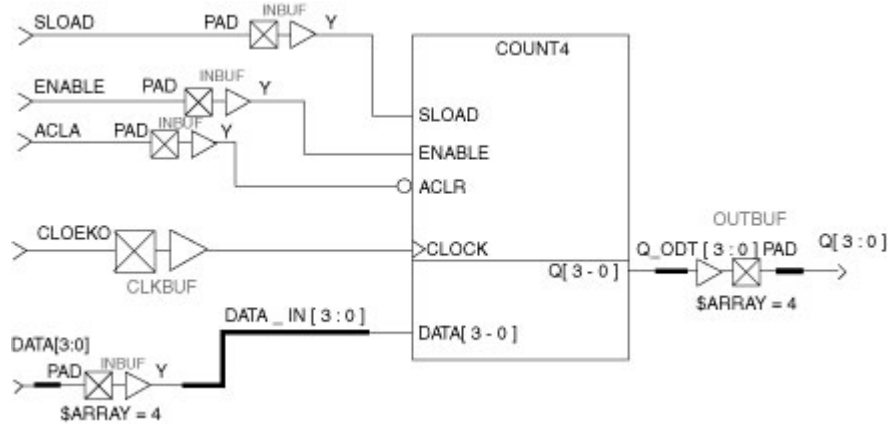

Figure 66 · Hierarchical Connectors with I/O Pads

## Design Flow

- To recreate a symbol for a specific block:
  - Delete all the symbol instantiations from the block's parent level
  - In the **Files** tab, delete the symbol from the Block Symbol Files folder
  - Delete the symbol file from your hard disk in the \viewdraw\sym folder
  - Make the desired modifications to the block
  - In ViewDraw for Actel, from the **File** menu, choose **Save + Check**
  - From Libero IDE, select the **Hierarchy** tab. Right-click the symbol and select **Create Symbol** from the menu
- Check the basic connectivity of your schematic from Libero IDE. Right-click the schematic file in the **Files** tab, and select **Check Schematic**.

## Importing Schematics

You can import any schematic created with ViewDraw AE.

### To import a schematic file:

- From the **File** menu, choose **Import Files**.
- In **Files of type**, choose **Schematics**.
- In **Look in**, navigate to the drive/folder where the file is located.
- Select the file to import and click **Open**. The schematic is imported into your project and appears in the Files tab, under Schematic files.

To open the schematic, click ViewDraw AE in the Design Flow window, or right-click the file in the File Manager and select **Open Schematic**.

## Opening a Schematic Source File

Use ViewDraw AE to edit your schematic files.

### **To open your schematic file:**

1. **Open** your project in Libero IDE.
2. Double-click the schematic file in the Files or Hierarchy tabs. ViewDraw AE opens with the file loaded.
3. From the **File** menu, choose **Save+Check** to create the required files for netlist generation. When Save + Check is complete, the Status Bar will say "Check complete, 0 errors and 0 warnings in project <name>." You must select Save +Check. Only selecting Save will not generate the needed WIR file for that block.
4. From the **File** menu, choose **Exit**. The schematic is saved to the project, appearing in both the Files tab and Hierarchy tabs. Your schematic file is updated in Libero.

## Using Design Block Cores from the Catalog - Schematic Entry

Use cores to:

- Create high-level modules, such as counters, multiplexors, multipliers, etc. that are optimized for Actel FPGAs.
- Create system-level building blocks, such as filters, FIFOs, and memories.

These can be instantiated into your schematic, Verilog design, or HDL design.

### **To generate cores for your schematic:**

1. Choose a core from the Catalog. Double-click to open the configuration options.
2. Select a core type (if necessary).
3. Configure the core.
4. In the **Save As** dialog box, leave the default selections and click **Save**. The file is added to your Libero IDE project; it appears in the Hierarchy tab.
2. **Create the Symbol**. In the Hierarchy tab, right-click the core module and choose **Create Symbol**. The symbol is created; it appears in the Files tab, under Block Symbol files.
3. To use the symbol, start ViewDraw.
4. From the **Add** menu, choose **Component**.
5. Select the new symbol, drag-and-drop to add it to your schematic.

## Synthesis Overview

Libero IDE works with the following synthesis tools:

- [Synplify](#) from Synopsys
- [LeonardoSpectrum](#) from Mentor Graphics
- [Precision RTL](#) from Mentor Graphics

While LeonardoSpectrum and Precision RTL are not part of the Libero IDE package, they can be integrated to work with Libero IDE. You can also integrate different versions of Synplify. To integrate tools, add them to your [project profile](#).



## Post-Synthesis Files

Post-synthesis files include:

- **<top>.edn** - EDIF netlist file; used for post-synthesis simulation in the Project Manager; also used by Designer to generate back-annotated files and complete layout
- **<top>.adb** - Designer project file, automatically generated by the Project Manager.
- **<top>.vhd** - Simulation file, automatically generated by the Project Manager.

To generate your EDIF netlist, use your Synthesis tool. You can also import your EDIF netlist named <top>.edn.

Icons:

-  (Green check) - Files are current; you can use the file for simulation or place-and-route.
-  (Yellow exclamation) - Files are out-of-date; something has changed since you created your post-synthesis file (you may have modified the source, family, default synthesis tool, package, etc.) Re-run synthesis to update the file. **You may use the out-of-date file for simulation or place-and-route if you wish.**

## Synplify AE and Synplify Pro AE

Libero IDEs integrated synthesis tool, Synplify Pro AE from Synopsys, takes your Verilog or VHDL Hardware Description Language source as input and outputs an optimized EDIF and HDL netlist.

Set your [tool profile](#) to the synplifypro.exe to take advantage of this tool.

**Note:** Note: See the Actel Attribute and Directive Summary in the Synplify online help for a list of attributes related to Actel devices.

### See Also

[Synthesizing your design with Synplify](#)

## Synthesizing Your Design with Synplify

1. In the Libero IDE, right-click the HDL file in the **Files** tab, or the top-level schematic for mixed schematic-HDL designs in the **Hierarchy**, and select **Synthesize**. Synplify starts and loads the appropriate design files, with a few pre-set default values.
2. From Synplify's **Project** menu, choose **Implementation Options**.
3. Set your specifications and click **OK**.

- Deactivate synthesis of the defparam statement. The defparam statement is only for simulation tools and is not intended for synthesis. Embed the defparam statement in between **translate\_on** and **translate\_off** synthesis directives as follows :

```
/* synthesis translate_off */
defparam M0.MEMORYFILE = "meminit.dat"
```

```
/*synthesis translate_on */
// rest of the code for synthesis
```

- Click the **RUN** button. Synplify compiles and synthesizes the design into an EDIF, \*.edn, file. Your EDIF netlist is then automatically translated by Libero into an HDL netlist. The resulting \*.edn and \*.vhd files are visible in the File Manager, under Implementation Files.

Should any errors appear after you click the Run button, you can edit the file using the Synplify editor. Double-click the file name in the Synplify window showing the loaded design files. Any changes you make are saved to your original design file in Libero.

- From the **File** menu, choose **Exit** to close Synplify. A dialog box asks you if you would like to save any settings that you have made while in Synplify. Click **Yes**.

**Note:** Note: See the Actel Attribute and Directive Summary in the Synplify online help for a list of attributes related to Actel devices.

**Note:** To add a clock constraint in Synplify you must add "n:<net\_name>" in your SDC file. If you put the net\_name only, it does not work.

### See Also

[Synplify AE](#)

## Synopsys Identify Debugger

Libero IDE integrates the Identify RTL debugger tool. It enables you to probe and debug your FPGA design directly in the source RTL. Use Identify software when the design behavior after programming is not in accordance with the simulation results.

To open the Identify RTL debugger, click the **Debugging** button in the **Project Flow** window.

### Identify features:

- Instrument and debug your FPGA directly from RTL source code .
- Internal design visibility at full speed.
- Incremental iteration - Design changes are made to the device from the Identify environment using incremental compile. You iterate in a fraction of the time it takes route the entire device.
- Debug and display results - You gather only the data you need using unique and complex triggering mechanisms.

You must have both the Identify RTL Debugger and the Identify Instrumentor to run the debugging flow outlined below.



**To use the Identify debugger:**

1. Create your source file (as usual) and run pre-synthesis simulation.
2. (Optional) Run through an entire flow (Synthesis - Designer - FlashPro) without starting Identify.
3. Click the Synthesis Synplify button in the Libero IDE to launch Synplify. From within Synplify, launch the Identify Instrumentor.
4. From the Instrumentor UI specify the sample clock, the breakpoints, and other signals to probe. Synplify creates a new synthesis implementation. Synthesize the design.
5. In Libero IDE, select the edif netlist of the Identify implementation you want to use in the flow.
6. Run Designer and FlashPro with the edif netlist you created with the Identify implementation.
7. Click the Debugging button in the Design Flow window to launch the Identify Debugger.

The Identify RTL Debugger, Synplify, and FlashPro must be synchronized in order to work properly. See the [Release Notes](#) for more information on which versions of the tools work together.

## Integrating Precision RTL

Libero IDE supports Precision RTL from Mentor Graphics.

**To integrate Precision RTL with your Libero IDE project:**

1. From the **Options** menu, choose **Profile**. The Project Profile dialog box appears.
2. Click **Add** and select **Synthesis**. The Add Tool dialog box appears.
3. Enter a name. This is the name that appears in the Project Profile dialog box.
4. Select Precision RTL.
5. Enter the location of Precision RTL and any additional parameters.
6. Click **OK**.
7. Select Precision RTL in the Project Profile dialog box and click **OK**.
8. Click **Precision RTL** in the Project Manager Project Flow window to start Precision RTL.

## Starting Precision RTL

Before you can start Precision RTL you must add it to your [project profile](#).

**To start Precision RTL to run synthesis:**

1. In Libero, right-click the HDL file in the Files tab or the top-level schematic for mixed schematic-HDL designs in the Hierarchy, and select **Synthesize**. Precision starts.
2. (Optional) Click **SetupDesign** to enter clock frequency, input delays and output delays.
3. (Optional) Click **Constraint** if you want to import a constraint file (\*.sdf).
4. Click **Compile** if you want to compile the design first.

5. If compile runs without error, click **Synthesize** to optimize the design for your target technology. To investigate errors in the log window, click the red error icon next to the error. An HDL Text Editor opens and the part of the HDL text which is the source of the error is automatically highlighted for you to modify. Click **Save** to save the changes you have made to the HDL text. Rerun Synthesis to get a successful run.
6. Click **Synthesize**. Precision RTL runs compile and then synthesizes your design.
7. The synthesized netlist (EDIF format) is visible under Implementation Files in the Files tab.
8. From the **File** menu, select **Exit** to close Precision RTL. A dialog box asks you if you would like to save any settings that you have made while in Precision. Click **Yes** to save the Precision project file (\*.psp).

### See Also

[Integrating Precision RTL](#)

[Profiles Dialog](#)

## Integrating LeonardoSpectrum

Libero IDE supports LeonardoSpectrum from Mentor Graphics.

### **To integrate LeonardoSpectrum with your Libero IDE project:**

1. From the **Options** menu, choose **Profile**. The Project Profile dialog box appears.
2. Click **Add** and select **Synthesis**. The Add Synthesis Tool dialog box appears.
3. Enter a name. This is the name that appears in the Project Profile dialog box.
4. Select LeonardoSpectrum.
5. Enter the location of LeonardoSpectrum and any additional parameters.
6. Click **OK**.
7. Select LeonardoSpectrum in the Project Profile dialog box and click **OK**.
8. Click **LeonardoSpectrum** in the Project Flow window to start LeonardoSpectrum.

### See Also

[Profiles Dialog](#)

## Synthesizing Your Design with LeonardoSpectrum

Before you can start Precision RTL you must add it to your [project profile](#).

### **To synthesizing your design with LeonardoSpectrum:**

1. In Libero, right-click the HDL file in the Files tab, or the top-level schematic for mixed schematic-HDL designs in the Hierarchy tab, and choose **Synthesize**. LeonardoSpectrum starts.
2. The Input Box is blank. Hit the Enter key on the keyboard and all the design files are loaded into the Input Box.
3. From the **Tools** menu, choose **Options**.

4. Deselect Automatically save and Restore Current Work Directory option.
5. Enter the **Clock Frequency** if you want to constrain the design.
6. Use the slide bar to select the level of Optimize Effort.
7. Click **RunFlow**. Click the red error icon next to the error for Information about errors. The HDL Text Editor opens and the part of the HDL text which is the source of the error is automatically highlighted for you to modify.
8. Click **Save** to save the changes you have made to the HDL text. Rerun Synthesis to get a successful run. The synthesized netlist is in EDIF format and is visible under Implementation Files in the Libero IDE Files tab.
9. From the **File** menu, choose **Exit** to close LeonardoSpectrum. A dialog box asks you if you would like to save any settings that you have made while in LeonardoSpectrum. Click **Yes** to save the LeonardoSpectrum project file (\*.lsp).

## Integration Issues

Some workarounds are required when using LeonardoSpectrum with Libero IDE.

### All versions of LeonardoSpectrum

- **LeonardoSpectrum log files are misplaced:** From the **Tools** menu, choose **Options**, and **SessionSettings**. Deselect Automatically Save and Restore Current Working Directory. This box must be unchecked in order for your log files to be passed back to Libero properly.

### LeonardoSpectrum v2003a Only

- **LeonardoSpectrum starts with empty windows:** When you first open LeonardoSpectrum from Libero, the Input window is blank and the output file is not specified. Also, the wrong family appears in the Technology window. To fix this, simply place your cursor in the transcript window and press Enter. All windows are updated.

## WaveFormer Pro™

WaveFormer Pro can be used to generate VHDL and Verilog stimulus-based testbenches for Libero IDE.

WaveFormer Pro fits into the Libero IDE, automatically extracting signal information from your HDL design files and producing HDL test bench code that can be used for VHDL or Verilog [simulation](#).

WaveFormer Pro generates VHDL and Verilog testbenches from drawn waveforms. Use WaveFormer Pro to generate the following:

- Reactive testbenches
- VHDL transport testbench (\*.vhd) that uses assignment statements
- VHDL wait testbench (\*.vhd) that uses wait statements
- Verilog (\*.v) file with Verilog stimulus statements

Update your project Profile to add WaveFormer Pro to your Libero IDE. See the [Setting your Project Profile](#) help topic for more information.

**Note:** Note: WaveFormer Pro comes with its own online help. After starting WaveFormer Pro, click the Help menu.

## Creating Your Testbench with WaveFormer Pro

[WaveFormer Pro](#) generates VHDL and Verilog testbenches from drawn waveforms. Create your testbench after you are done creating your design and wish to perform simulation. If you do not have WaveFormer Pro, create your testbench with an alternative third-party tool.

There are five basic steps for creating testbenches using WaveFormer Pro and Libero IDE. These steps are described in detail in the following sections.

### **To create a testbench using WaveFormer Pro:**

1. Click **WaveFormer Pro** in the **Project Flow** window. WaveFormer Pro starts and your signal information is imported automatically.
2. Using WaveFormer Pro, draw the waveforms to describe the testbench.
3. From the **Export** menu, choose **Export Timing Diagram** and choose the save type as \*.tim or \*.btim. This saves the waveforms.
4. (Optional) Add VHDL Libraries and Use Clauses for VHDL export. These libraries or packages can be included using the VHDL Libraries and Use Clauses dialog. From the **Options** menu, select the **VHDL Libraries and Use Clauses** menu item to open this dialog.
5. From the **Export** menu, choose **Export Timing Diagram** and choose the type of file to generate. To generate a plain testbench model (which does not instantiate your model under test), choose one of the VHDL or Verilog scripts. To simulate with the testbench model, you will need to write a top-level model that instantiates the testbench model and the model under test. Below is a list of VHDL and Verilog testbench generation scripts:
  - VHDL Wait (\*.vhd)s
  - VHDL Transport (\*.vhd)s
  - Verilog
5. From the **File** menu, choose **Exit**.

**Note:** Note: If you added extra signals to the testbench and do not want to export those signals, then double-click the signal's names to open the Signals Properties dialog and clear the Export check box.

Synplify always changes the data type to std\_logic or std\_logic\_vector in the post\_synthesis netlist. If your top-level entity port is not std\_logic or std\_logic\_vector and you need to run post-synthesis or post-layout simulation, you need to change the data type in WFL.

### **To create two testbenches:**

1. Open the \*.tim file and select the special data type signal, right-click and choose **Edit Selected Signal**.

2. Choose `std_logic` or `std_logic_vector` under VHDL and click **Save**.

## ModelSim™ AE

ModelSim Actel Edition (AE) is a custom edition of ModelSim PE that is integrated into Libero's design environment. ModelSim for Actel is an OEM edition of Model Technology Incorporated's (MTI) tools. ModelSim for Actel supports VHDL or Verilog. It only works with Actel libraries and is supported by Actel.

Other editions of ModelSim are supported by Libero IDE. To use other editions of ModelSim with Libero IDE, simply do not install ModelSim AE from the Libero CD.

**Note:** Note: ModelSim for Actel comes with its own online help and documentation. After starting ModelSim, click the *Help* menu.

## Setting Simulation Options

You can set a variety of simulation options for your project.

### To set your simulation options:

1. From the **Options** menu, choose **ProjectSettings**.
2. Click **Simulation**.
3. Select your options and click **OK**.
4. Use automatic Do file: Select if you do not want Libero to initialize ModelSim.
5. User defined Do file: Enter the Do file name or click the browse button.

Automatic Do file content

- **Include Do file** - Select to execute the `wave.do` or other specified Do file. Use the `wave.do` file to customize the ModelSim Waveform window display settings.
- **Simulation Run Time** - Specify how long the simulation should run in nanoseconds. If the value is 0, or if the field is empty, there will not be a run command included in the `run.do` file.
- **Testbench module/entity name** - Specify the name of your testbench entity name. Default is "testbench," the value used by WaveFormer Pro.
- **Top Level instance name in the testbench** - Default is `<top_0>`, the value used by WaveFormer Pro. The Libero IDE Project Manager replaces `<top>` with the actual top level macro when you run ModelSim.
- **Vsim Command Type** - Select Minimum (Min), Typical (Typ), or Maximum (Max).
- **Resolution:** The default is family-specific, but you can customize it to fit your needs. Some custom simulation resolutions may not work with your simulation library. For example, simulation resolutions above 1 ns will cause errors if you are using SX-A devices (the simulation errors out because of an infinite zero-delay loop). Consult your simulation help for more information on how to work with your simulation library and detect infinite zero-delay loops caused by high resolution values.

Family	Default Resolution
ACT1, ACT2, ACT3	1 ns
MX	1 ns
DX	1 ns
SX, SX-A	1 ns
eX	1 ns
Axcelerator	1 ps
ProASIC	1 ps
ProASICPLUS	1 ps
ProASIC3/E	1 ps
IGLOO/e	1 ps
Fusion	1 ps

- **Vsim additional options:** Text entered in this field is added to the vsim command.
- **ModelSim library path:** Enables you to choose the ModelSim default library for your device, or to specify your own ModelSim library. Enter the full pathname of your own library to use it for simulation.
- **Generate VCD file:** Select this checkbox to have ModelSim automatically generate a VCD file based on the current simulation. VCD files can be [imported into Designer](#) and used in SmartPower. For best results, we recommend that a postlayout simulation be used to generate the VCD.
- **VCD filename:** Specify the name of the VCD file that will be automatically generated by ModelSim
- **Default:** Restores factory settings.

## Selecting a Stimulus File for Simulation

Before running simulation, you must associate a testbench. If you attempt to run simulation without an associated testbench, the Project Manager asks you to associate a testbench or open ModelSim without a testbench.

### To associate a stimulus:

1. Run simulation or right-click the top level module in the Hierarchy Menu and select **Organize Stimulus File** from the right-click menu. The Organize Stimulus dialog box appears.

2. Associate your testbench(es):

In the Organize Stimulus dialog box, all the stimulus files in the current Libero IDE project appear in the left *Stimulus Files in the Project* list box. Files already associated with the block appear in the *Associated Files* list box.

In most cases you will only have one testbench associated with your block. However, if you want simultaneous association of multiple testbench files for one simulation session, as in the case of PCI cores, add multiple files to the Associated Files dialog box.

**To add a testbench:** Select the testbench you want to associate with the block in the *Stimulus files in the project* list box and click **Add** to add it to the Associated Files list.

**To remove a testbench:** To remove or change the file(s) in the Associated files list box, select the file(s) and click **Remove**.

**To order testbenches:** Use the up and down arrows to define the order you want the testbenches compiled. The top level-entity should be at the bottom of the list.

3. When you are satisfied with the Associated File(s) list, click **OK**. A checkmark appears next to WaveFormer Pro in the Project Flow window to let you know that a testbench has been associated with the block.

## Selecting Additional Modules for Simulation

Libero IDE passes all the source files related to the top-level module to simulation .

If you need additional modules in simulation, right-click the module name in the Hierarchy and select **Properties** from the shortcut menu. Select the **Included for Simulation** check box to pass the file to simulation.

You must repeat this for each additional module you wish to pass to simulation.

## Performing Functional Simulation

### **To perform functional simulation:**

1. Create your [testbench](#).
2. Right-click the top level module in the **Hierarchy** tab and choose **Organize Stimulus File** from the right-click menu.

In the Organize Stimulus dialog box, all the stimulus files in the current Libero IDE project appear in the **Stimulus Files in the Project** list box. Files already associated with the block appear in the **Associated Files** list box.

In most cases you will only have one testbench associated with your block. However, if you want simultaneous association of multiple testbench files for one simulation session, as in the case of PCI cores, add multiple files to the **Associated Files** dialog box.

**To add a testbench:** Select the testbench you want to associate with the block in the **Stimulus Files in the Project** list box and click **Add** to add it to the Associated Files list.

**To remove a testbench:** To remove or change the file(s) in the Associated Files list box, select the file(s) and click **Remove**.

**To order testbenches:** Use the up and down arrows to define the order you want the testbenches compiled.

3. When you are satisfied with the Associated File(s) list, click **OK**.
4. Start ModelSim AE by doing one of the following:
  - Right-click the top level module in the Design Hierarchy window and choose **Run Pre-Synthesis Simulation** or **Run Post-Synthesis Simulation**.
  - Click **ModelSim Simulation** in the **Project Flow Window**.

ModelSim starts and compiles the appropriate source files. When the compilation completes, the simulator runs for 1  $\mu$ s and the Wave window opens to display the simulation results.

5. Scroll in the Wave window to verify that the logic of your design functions as intended. Use the zoom buttons to zoom in and out as necessary.
6. From the **File** menu, select **Quit**.

## Performing CoreConsole Functional Simulation

Libero overwrites all the existing files of the Core when you import a CoreConsole project (including testbenches). Save copies of your CoreConsole project stimulus files with new names if you wish to keep them.

You must import a CoreConsole BFM file into the Libero IDE in order to complete functional simulation (the BFM is a stimulus file that you can edit to extend the testbench). VEC files are generated automatically from the BFM when you run ModelSim.

The Project Manager overwrites your BFM file if you re-import your CoreConsole project. Edit and save your BFM outside the Libero IDE project to prevent losing your changes. After you re-import your core-console project, you can import your modified BFM again.

### **To perform functional simulation of a CoreConsole project:**

1. Right-click a stitched module of the CoreConsole project or the top level of the CoreConsole project and select **Set as root**.
3. Start ModelSim AE by doing one of the following:
  - Right-click the top level module in the Design Hierarchy window and choose **Run Pre-Synthesis Simulation, Run Post-Synthesis Simulation**.
  - Click **ModelSim Simulation** in the **Project Flow Window**.

ModelSim starts and compiles the appropriate source files. When the compilation completes, the simulator runs for 1  $\mu$ s and the Wave window opens to display the simulation results.

5. Scroll in the Wave window to verify that the logic of your design functions as intended. Use the zoom buttons to zoom in and out as necessary.
6. From the **File** menu, select **Quit**.



## Performing Timing Simulation

The steps for performing [functional](#) and timing simulation are nearly identical. Functional simulation is performed before place-and-route and simulates only the functionality of the logic in the design. Timing simulation is performed after the design has gone through place-and-route and uses timing information based on the delays in the placed and routed designs.

Timing simulation includes much more detailed timing information for the targeted device. Timing simulation requires a testbench.

### **To perform timing simulation:**

1. If you have not done so, back-annotate your design and create your testbench.
2. Right-click the top level module in the **Hierarchy** and choose **Organize Stimulus File** from the right-click menu.

In the Organize Stimulus dialog box, all the stimulus files in the current Libero IDE project appear in the *Stimulus Files in the Project* list box. Files already associated with the block appear in the *Associated Files* list box.

In most cases, you will only have one testbench associated with your block. However, if you want simultaneous association of multiple testbench files for one simulation session, as in the case of PCI cores, add multiple files to the *Associated Files* dialog box.

**To add a testbench:** Select the testbench you want to associate with the block in the *Stimulus Files in the Project* list box and click **Add** to add it to the Associated Files list.

**To remove a testbench:** To remove or change the file(s) in the Associated Files list box, select the file(s) and click **Remove**.

**To order testbenches:** Use the up and down arrows to define the order you want the testbenches compiled.

3. When you are satisfied with the Associated File(s) list, click **OK**.
4. Click **ModelSim Simulation** in the Project Flow window. The ModelSim simulator starts and compiles the source files. When the compilation completes, the simulator runs for 1  $\mu$ S and a Wave window opens to display the simulation results.
5. Scroll in the Wave window to verify the logic works as intended. Use the cursor and zoom buttons to zoom in and out and measure timing delays. If you did not create a testbench with WaveFormer Pro, you may get error messages with the vsim command if the instance names of your testbench do not follow the same conventions as WaveFormer Pro. Ignore the error message and type the correct vsim command.
6. When you are done, from the **File** menu, choose **Quit**.

# Welcome to Designer

The Designer interface offers both automated and manual flows, with the push-button flow achieving the optimal solution in the shortest cycle.

Actel's Designer software is integrated with the Libero IDE Project Manager. Use the Designer software to implement your design.

To implement your design:

1. Right-click the top level module in the **Hierarchy** and choose **Run Designer**, or click **Designer** in the Project Flow window. Designer starts and loads your files from Libero.
2. Set up your device. From the **Tools** menu, select Device Selection. In the Device Selection Wizard, select the die, package, speed grade, voltage, and operating conditions. Make your selections and click **Next** to complete the steps
3. In Designer, click **Compile** in the design flow window. The log window displays the utilization of the selected device. When compile has completed, the Compile box in the Design Flow window turns green.
4. Once you have successfully compiled your design, you can use Designer's User's tool to optimize your design. To start a tool, simply click it in the flow tree. The tools include:

Tool	Function	Supported Families
PinEditor	Package-level floorplanner and I/O attribute editor	All
ChipPlanner	Logic viewer, placement- and floorplanning tool	IGLOO, ProASIC3, SmartFusion, Fusion, ProASIC <sup>PLUS</sup> , ProASIC, Axcelerator, RTAX-S, eX, and SX-A
ChipEditor	Logic viewer and placement tool	SX, MX, 3200DX, ACT3, ACT2, ACT1
NetlistViewer	Design schematic viewer	All
SmartPower	Power analysis tool	IGLOO, ProASIC3, SmartFusion, Fusion, ProASIC <sup>PLUS</sup> , ProASIC, Axcelerator, RTAX-S, eX, and SX-A
SmartTime and Timer	Static timing analysis and constraints editor	All

Tool	Function	Supported Families
	(SmartTime only)	
I/O Attribute Editor	Edit I/O attributes, layout	IGLOO, ProASIC3, SmartFusion, Fusion, ProASIC <sup>PLUS</sup> , ProASIC, Axcelerator, RTAX-S, eX, and SX-A

5. Click [Layout](#) in the Design Flow Window to place-and-route your design.
6. Click **Back-Annotate** in the Design Flow Window. Choose SDF as CAE type and appropriate simulation language. Select Netlist in the Export Additional Files area and Click **OK**. If you are exporting files post-layout, Designer exports <top>\_ba.vhd and <top>\_ba.sdf to your Libero project. The “\_ba” is added by Libero to identify these for back-annotation purposes. <top> is the top root name. Pre-layout exported files do not contain “\_ba” and are exported simply as \*.vhd and \*.sdf. The files are visible in the Files tab, under Implementation Files.
7. Click **Programming File** in the design flow tree if you wish to create a programming file for your design. This step can be performed later after you are satisfied with the back-annotated timing simulation.
8. From the **File** menu, select **Exit**. Click **Yes** to save the design before closing Designer. Designer saves all of the design information in an \*.adb file. The <project>.adb file is visible in the File Manger, in the [Designer Views](#) folder. To re-open this file at any time, simply double-click it.

## Starting Designer

### **To start Designer from Libero IDE:**

In the Project Flow window, click **Designer Place-and-Route**.

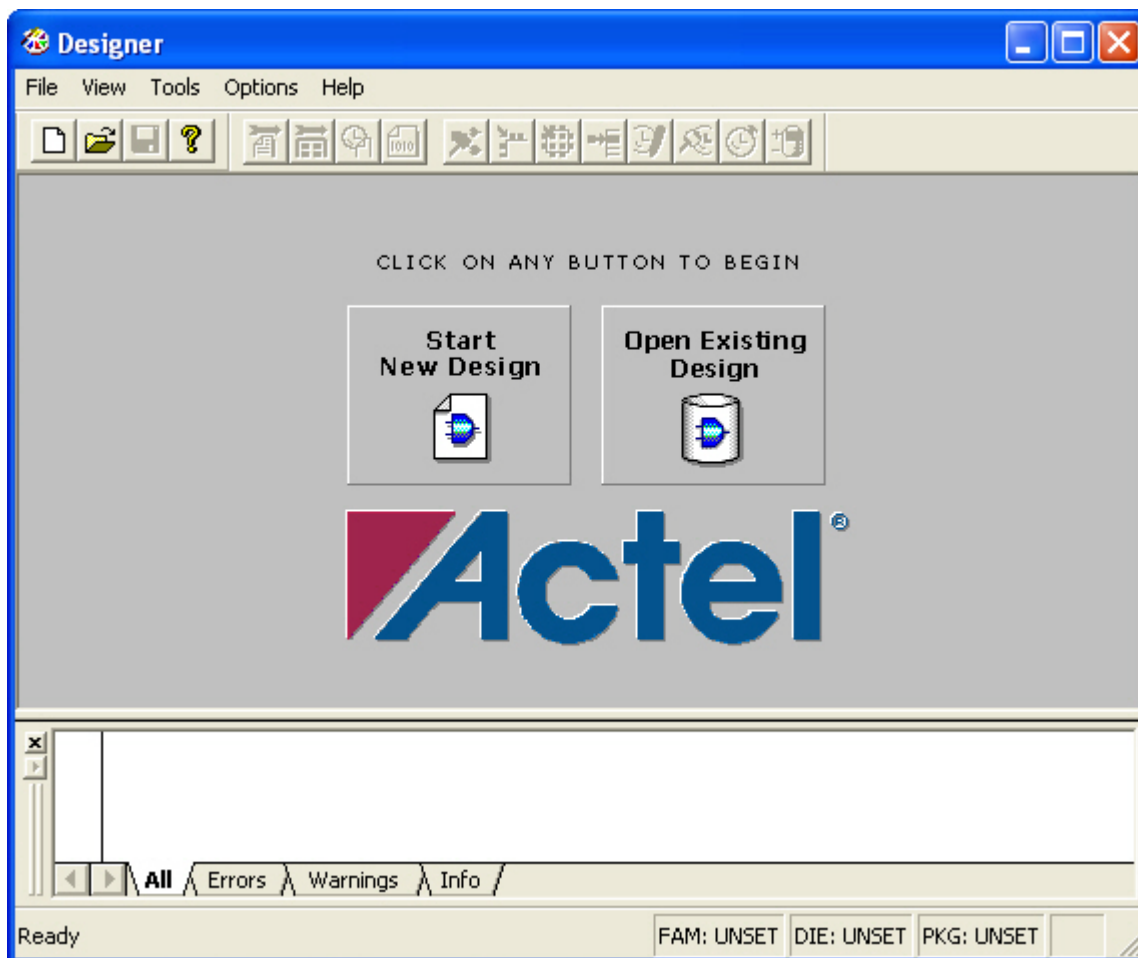

## Starting a New Design

To begin a new design session, you must start a new design or open an existing design.

Starting a new design creates an Actel ADB file. ADB files are proprietary Actel project files.

### **To start a new design:**

1. Click **Start New Design** in the Designer main window, or from the **File** menu, choose **New**. This displays the Setup Design dialog box.  
**Note: The Actel ADB file memory requirement is equivalent to 2x the size of the ADB file. If your computer does not have 2x the size of your ADB file's memory available, please make memory available on your hard drive.**
2. Setup Design:
  - Enter a **Design Name**. The design name is used in reports and as the default name when saving or exporting files. The Design Name field is disabled when you open

Designer place-and-route software from the Libero IDE. If you wish to change your design name, from the **File** menu, choose **Save As**, and save your file outside of the Libero folder structure.

- If you are creating a Designer Block, select the **Enable Designer Block creation** checkbox. [Designer Blocks](#) are useful if you wish to duplicate design elements. Once you place-and-route and publish your Designer Block you can instantiate the block in as many designs as you like. Note that you cannot program your design in Designer Block mode, only publish the Designer Block files.
- Select an **Actel Family** from the drop-down menu list.
- Specify a **Working Directory**. Click **Browse** to locate a directory. The Working Directory field is disabled when you open Designer place-and-route software from the Libero IDE. If you wish to change your working directory, you must change your filename. To do so, from the **File** menu, select **Save As**, and save your file outside of the Libero folder structure.

3. Click **OK**. The Designer custom design flow window appears. All tools and commands are activated.

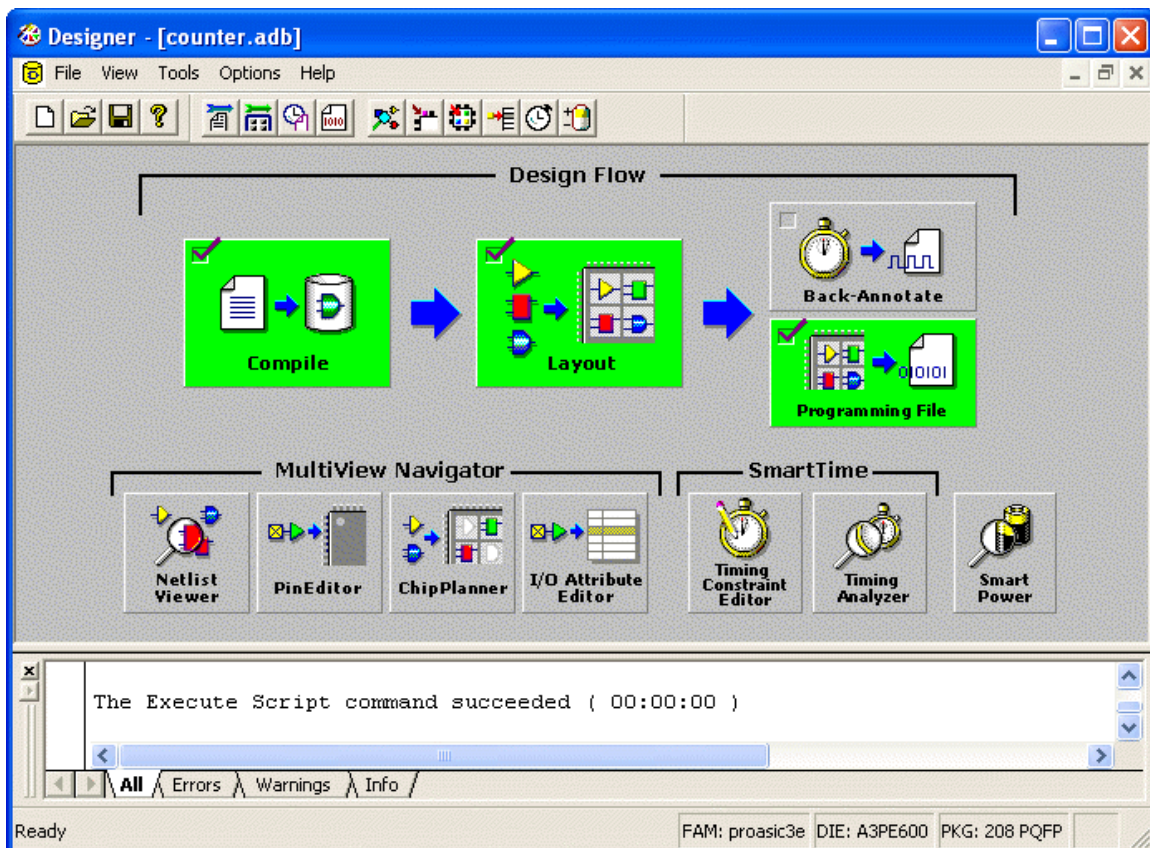

Figure 67 · Designer:New Design

## Opening an existing design

### **To open an existing design:**

1. Click **Open Existing Design** or from the **File** menu, choose **Open**. This displays the Open dialog box.
2. Select **File**. Type the full path name of the .adb file in the File Name box, or select the file from the list.
3. Click **Open**. The Designer custom design flow window appears and all tools and commands are activated. When you open an existing design, Designer checks to see if you have modified your netlist since the last time you imported the netlist into this design. If you have, Designer prompts you to re-import your netlist.

### **See Also**

[Starting Designer](#)

[Starting a new design](#)

## Opening designs created in previous versions

Designer can directly open designs created with previous versions of the Designer software.

If your design was created in version 3.1 or earlier, contact the Actel Technical Support department or go to <http://www.actel.com/support/> for information on converting your design.

All existing die, package, pin assignments, and place-and-route information is read and maintained. Designs created in previous versions of the software may need library conversions when loaded into the Designer environment. If your design requires this conversion, Designer prompts you to allow the software to update the design to the new library before you attempt to start any of the Designer features.

## Opening Locked Files

Designer notifies you if a lock has been established on your file. You may receive a warning or an error message when opening a design with a lock.

### **Warning**

Designer warns you when opening a design that was not closed properly or may be open somewhere else. You can choose to recover the unsaved edits.

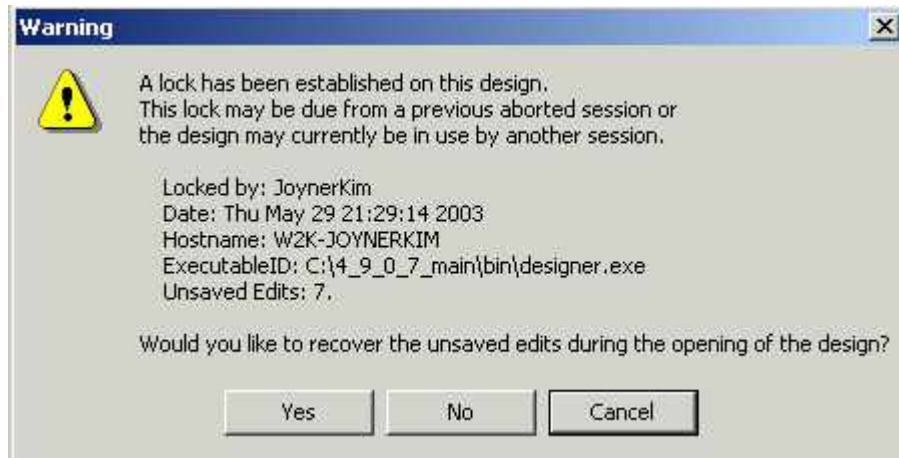

Figure 68 · Warning: Locked File

## Error

When opening a design, you may receive an error that the file cannot be opened because the lock file is old. You cannot recover any unsaved edits.

### **To open a design with an old lock file:**

1. Go to the design directory.
2. Locate the design \*.adb file and corresponding \*.lok file.
3. Delete the \*.lok file.
4. Return to Designer and open the design.

Name	Size	Type	Modified
ada01928.4	87 KB	4 File	2/7/2003 10:24 PM
cctester.adb	87 KB	Actel Designer Desi...	12/11/2001 10:39 AM
cctester.lok	1 KB	LOK File	2/7/2003 10:24 PM

## Starting Other Applications from Designer (PC Only)

You can start any application from Designer that you have added to the Tools menu.

### **To add an application to the Tools menu:**

1. From the **Tools** menu, choose **Customize**.
2. Enter the application name in the Menu Text area. This text will appear in the **Tools** command menu.
3. Enter the command to execute, or click the **Browse** button to select an executable filename. If the location of the command to execute is not in your path, you must include the absolute path when specifying the command.
4. In the Arguments text box, enter the command-line arguments that will be passed to the command when executing.

5. In the Initial Directory field, type the absolute path of the directory in which the application will initially be executed.
6. Click **Add**.
7. When you are finished adding tools, click **OK**. The application name you added appears in the **Tools** menu.

**To remove an application from the Tools menu:**

1. From the **Tools** menu, choose **Customize**.
2. Select the application to remove and click **Remove**.
3. When you are finished removing applications, click **OK**.

**To order applications in the Tools menu:**

1. From the **Tools** menu, choose **Customize**.
2. Reorder the tools by selecting one at a time and clicking the **Move Up** or **Move Down** buttons.
3. Click **OK** when you are finished. The tools will appear in the **Tools** menu in the same order as they do in the **Menu Contents** list box.

## About your Installation

**To display information about your license:**

From the **Start** menu, choose **Programs**, and then click the **Actel software folder** and select About Your Installation. The software displays your complete license configuration, all Actel-installed software and versions, as well as your HostID and disk volume serial number.

You can also select **License Details** from the **Help** menu in Designer to view your license information.

## Directory preferences

When executing a command or function such as Open or Save, Designer uses the directory you specify as the start-up directory.

**To specify your directory preferences:**

1. From the **File** menu, choose **Preferences**.
2. Click the **Directory** tab.
3. Specify your Startup directory.
4. Select your working directory options:
5. **To design file's directory when opening design:** Select to automatically change directories when opening a design.
6. **To design file's directory when saving design:** Select to automatically change directories when saving a design.



7. **To script file's directory when executing script:** Select to automatically change directories when executing a script.
8. **Add design name to working directory when creating design:** Select to enable a design name folder to be automatically created in the working directory when creating a new design.
9. Click **OK**.

## Updates

The Updates tab in the Preferences dialog box allows you to set your automatic software update preferences.

### **To set your automatic software update preferences:**

1. From the **File** menu, choose **Preferences** and **Updates**.
2. Choose one of the following options and click **OK**.
  - **Automatically check for updates at startup:** Select to be notified of updates when you start Designer.
  - **Remind me to check for updates at startup:** Select to be asked if you want to check for a software update when you start Designer.
  - **Do not check for updates or remind me at startup:** Select if you do not want to check for software updates at startup.

To manually check for software updates, from the **Help** menu, select **Check for Software Updates**.

**Note:** Note: This feature requires an internet connection.

## Proxy

A Proxy improves access to the Actel server. From the **File** menu, choose **Preferences**.

Click the **Proxy** tab to set your Proxy preferences.

### **To enable the proxy:**

1. Select **I use a proxy**.
2. Type the proxy name in the text field.
3. Click **OK**.

## File association (PC only)

Several programs, including Designer, create files with the ADB extension.

Use the File Association tab in the Preferences dialog box to specify Designer as the default program for files with the .adb extension. Doing so starts Designer whenever a file with the ADB extension is double clicked.

You must have rights to modify the HKEY\_CLASSES\_ROOT of the registry of the machine to set Designer file association. If you do not have rights to modify the registry, Designer ignores your settings.

**To associate \*.adb files with the Designer application:**

1. From the **File** menu, choose **Preferences**.
2. Select **Check the default file association (\*.adb) at startup** check box to associate ADB files with the Designer application. Clear the box if you do not want Designer to start when clicking a file with the ADB extension.
3. Click **OK**.

## Setting your Log Window preferences

Errors, Warnings, and Informational messages are color-coded in the log window. You can change the default colors by using the log Window tab in the Preferences dialog box.

**To change colors in the log window:**

1. From the **File** menu, choose **Preferences**.
2. Click the **Log Window** tab in the Preferences dialog box.
3. Select your new default colors and click **OK**.

The default color settings for the log window are:

Message Type	Color
Errors	Red
Warnings	Light Blue
Informational	Black
Linked	Dark Blue

The default preference is to Clear the log window automatically. This clears the Designer log window each time you close or open a new design in Designer. Clear the box if you want Designer to leave the log information after you close a design.

## PDF Reader (UNIX Only)

Use the PDF Reader tab to bring up the online manuals. Enter the default reader's name with the full path or click **Browse**.

## Web Browser (UNIX Only)

Specify the default web browser you wish to use on the UNIX platform. The web browser displays the online help.

---

## Device Selection

## Device Selection Wizard

After you import your source files, the Device Selection Wizard helps you specify the device, package, and other operating conditions. You must complete these steps before your netlist can be compiled.

The wizard steps include:

- [Selecting die, package, speed, and voltage](#)
- [Selecting variations \(reserve pins and I/O attributes\)](#)
- [Setting operating conditions](#)

## Setting Die, Package, Speed, and Voltage

The first screen in the [Device Selection Wizard](#) allows you to set die, package, speed, and voltage.

1. In the **Tools** menu, choose **Device Selection** to start the Device Selection Wizard.
2. Select **Die** and **Package**. Select a die from the Die list. Available packages are listed for each die.
3. Specify **Speed**.
4. Select **Die Voltage**. Select from the available settings in the Die Voltage drop-down menu. Two numbers separated by a "/" are shown if mixed voltages are supported. Two numbers separated by a "-" are shown if a wide range voltage is supported. If two voltages are shown, the first number is the I/O voltage and the second number is the core (array) voltage.
5. Click **Next** to set reserve pins and I/O Attributes.

## Device Variations

The second screen in the [Device Selection Wizard](#) enables you to set reserve JTAG and probe pins and the default I/O standard.

### **To select reserve pins and default I/O standard:**

1. Select your reserve pins:
2. Select the **Reserve JTAG** check box to reserve the JTAG pins "TDI," "TMS," "TCK," and "TDO" during layout.
3. Select the **Reserve JTAG Reset** check box to reserve the JTAG reset Pin "TRST" during layout.
4. Select the **Reserve Probe** check box to reserve the Probe pins "PRA," "PRB," "SDI," and "DCLK" during layout. Reserve Pins are not selectable for the Axcelerator, ProASIC, and ProASIC<sup>PLUS</sup> families.
5. Select an I/O attribute. The I/O Attributes section notifies you if your device supports the programming of I/O attributes on a per-pin basis. For the Axcelerator family, the I/O Attribute section allows you to set the default I/O standard for the I/O banks.
6. Click **Next** to set operating conditions.

## Setting Operating Conditions

Operating Conditions, Step 3 of the [Device Selection Wizard](#), enables you to define the voltage and temperature ranges a device encounters in a working system. The operating condition range entered here is used by SmartTime, the timing report, and the back-annotation function. These tools enable you to analyze worst-, typical-, and best-case timing.

### Junction Temperature

Select a junction temperature. Supported ranges include:

- Commercial (COM)
- Industrial (IND)
- Military (MIL)
- Automotive
- TGrade1
- TGrade2
- Custom

Consult the Actel Data Sheet, available at <http://www.actel.com/techdocs/ds/>, to find out which temperature range you should use.

If you select Custom, edit the Best, Typical, and Worst fields. Modify the range to the desired value (real) such that Best < Typical < Worst.

You can calculate junction temperature from values in the Actel Data Sheet, available at <http://www.actel.com/techdocs/ds/>.

The temperature range represents the junction temperature of the device. For commercial and industrial devices, the junction temperature is a function of ambient temperature, air flow, and power consumption.

For military devices, the junction temperature is a function of the case temperature, air flow, and power consumption. Because Actel devices are CMOS, power consumption must be calculated for each design. For most low power applications (e.g. 250mW), the default conditions are adequate.

Performance decreases approximately 2.5% for every 10 degrees C that the temperature values increase. Refer to the SmartPower online help for more information about power consumption.

### Voltage

Select a voltage:

- Commercial (COM)
- Industrial (IND)
- Military (MIL)

- Automotive
- Custom

If you select Custom, you may enter the values for Best, Typical, and Worst.

#### **For IGLOO, ProASIC3, SmartFusion and Fusion families of devices only**

Select a voltage for VCCA and VCCI:

- Commercial (COM)
- Industrial (IND)
- Military (MIL)
- Automotive
- Custom

If you select Custom, you may enter the values for Best, Typical, and Worst.

Wide range voltage for die voltage (VCCA) and VCCI is available for ProASIC3L and 1.2V IGLOO devices. To specify the wide range voltage for VCCI check the **Wide Range** option and enter the values for Best, Typical, and Worst.

## **Radiation Derating**

Conservative post-radiation performance estimates are available for some radiation tolerant devices based upon the number of KRads the device is expected to be subjected to. Radiation effects vary by device lot and may not be completely representative of the lot you are using. Post-radiation timing numbers are only meant to be a guide and are not a guarantee of performance. Customers must consult the specific radiation performance report for the specific lot used. Post radiation exposure estimates currently only affect timing numbers. The SmartPower power analysis tool is not affected by changing the radiation exposure value.

## **RTSX-S and RTAX-S ONLY - Radiation Derating**

This option is only available for RTSX-S and RTAX-S devices. The valid range is integer values from 0 to 300, and the units are in KRads. Modifying this selection impacts the timing derating in SmartTime and back-annotating SDF files, so when you modify this value, you must extract a new SDF file from Designer and re-evaluate the timing of your design. It does not affect the device configuration.

## **Changing Design name and family**

Design name and family are set when you create a new design. However, you can change this information for existing designs. If you change the family, you must re-import the netlist. Use the following procedure to change the name of a design and the targeted Actel family for the design.

### **To change the design name or family in Designer:**

1. In the Designer **Tools** menu, choose **Setup Design**. This displays the Setup Design dialog box.

2. Specify the design name and family.
3. Click **OK**. Refer to the Actel datasheet for your device for family specifications.

You may wish to migrate your SX device to an SX-A device. The SX to SX-A compatible family change option is available in the Device Selection wizard.

#### **To migrate your SX design to SX-A:**

1. Open your SX design.
2. From the Designer **Tools** menu, choose **Device Selection**.
3. Select **SXA** from the **Change to** drop-down menu, and proceed in the [Device Selection Wizard](#) to complete the migration. You must re-compile and layout your design to run the Designer User Tools.

## Changing device information

Device and package information, device variations, and operating conditions are set when you import a netlist and compile a new design. However, you can change this information for existing designs.

#### **To change device information for existing designs:**

1. In the **Tools** menu, choose **Device Selection**. The Device Selection Wizard appears.
2. Select Die, Package, and Speed Grade and click **Next**. (You must select a die and package to continue.)
3. Select Device Variations and click **Next**.
4. Select Operating Conditions and click **Finish**.

Refer to the Actel FPGA Data Book or call your local Actel Sales Representative for information about device, package, speed grade, variations, and operating conditions.

### **Compatible Die Change**

When you change the device, some design information can be preserved depending on the type of change.

### **Changing Die Revisions**

If you change the die from one technology to another, all information except timing is preserved. An example is changing an A1020A (1.2µm) to an A1020B (1.0µm) while keeping the package the same.

### **Device Change Only**

Constraint and pin information is preserved, when possible. An example is changing an A1240A in a PL84 package to an A1280A in a PL84 package.

### **Repackager Function (Non-Axcelerator families only)**

When the package is changed (for the same device), the Repackager automatically attempts to preserve the existing pin and Layout information by mapping external pin names based on the physical bonding diagrams. This always works when changing from a smaller package to a larger package (or one of the same size). When changing to a smaller

package, the Repackager determines if any of the currently assigned I/Os are mapped differently on the smaller package. If any of the I/Os are mapped differently, then the layout is invalidated and the unassigned pins identified.

## Importing Source Files

Source files include your netlist and constraint files.

Source files are files created by outside tools that will be tracked (audited) to better coordinate the design changes. If you wish, you may import some files as [auxiliary files](#). Auxiliary files are not audited, but you do not have to re-compile your design after you import them.

Source Files	File Type Extension	Family
EDIF	*.ed*	All
Verilog	*.v	All
VHDL	*.vhd	All
Actel ADL Netlist	*.adl	All, except ACT1, ACT2, ACT3
Criticality	*.crt	ACT1, ACT2, ACT3, MX, 1200XL, DX
ProASIC Constraint File	*.gcf	ProASICPLUS
Physical Design Constraint File	*.pdc	IGLOO, ProASIC3, SmartFusion, Fusion, and Axcelerator
Synopsys Constraint File	*.sdc	IGLOO, ProASIC3, SmartFusion, Fusion, ProASIC <sup>PLUS</sup> , ProASIC, Axcelerator, SX-S, SX-A, and eX
CoreConsole Database File	*.cdb*	IGLOO, ProASIC3, SmartFusion and Fusion; Designer uses the CDB file to place the CoreMP7 cores and Designer blocks.

The choice of source files is family dependent. Only supported source files are displayed in the Import Source dialog box. If you are working on a new design or if you have changed your netlist, then you must re-import your netlist into Designer.



**To import a source file:**

1. From the **File** menu, choose **Import Source Files**. This displays the Import Source Files dialog box, as shown in the figure below.

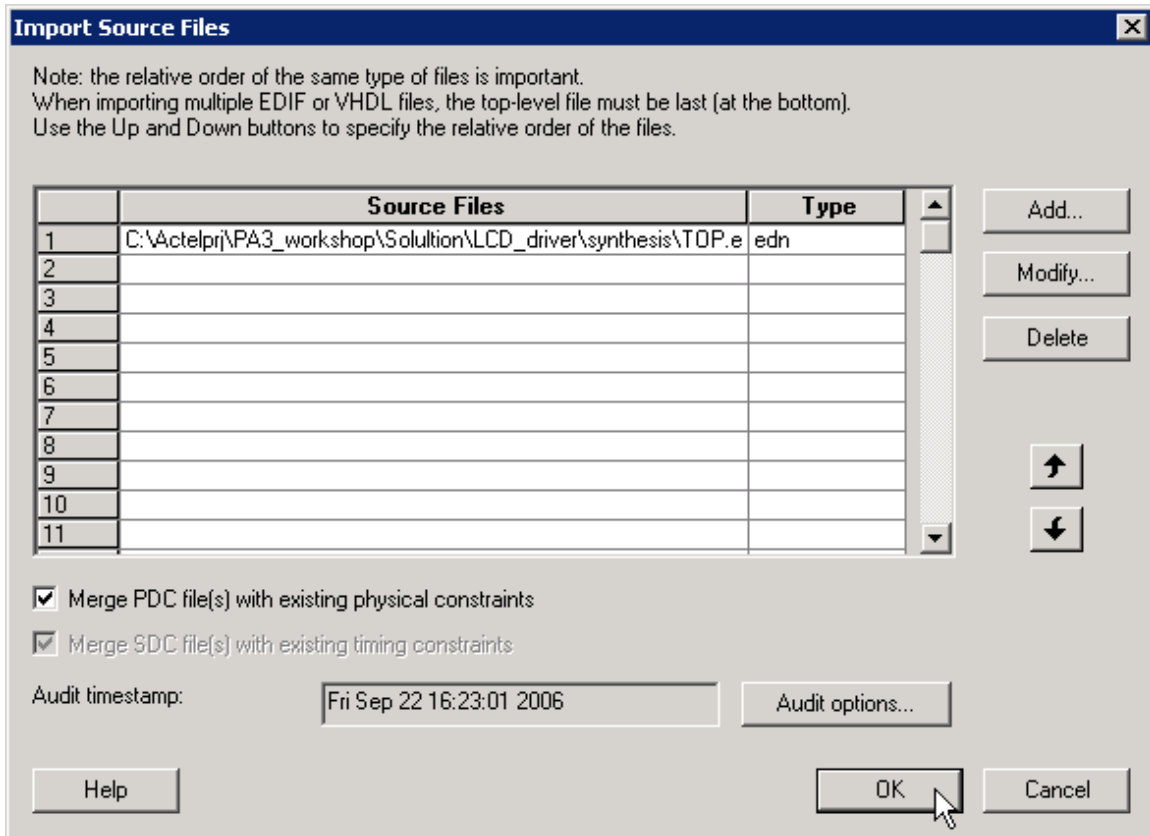

Figure 69 · Import Source Files Dialog Box

2. Click **Add**. The Add Source Files dialog appears.
3. Select the file you want to import and click **Import**. The File is added to the Import Source Files dialog box.
4. Add more source files to the list. All files added to the Import Source Files dialog box are imported at the same time. To modify a file, select the file and click **Modify**. To delete a file, select the file and click **Delete**.
5. Libero can only audit local files. If you launch Designer from Libero, you need to copy the files locally. Select **Copy locally** to copy these files to your local project folder.

Note: This button is available when design (ADB) opened by Designer is part of a Libero IDEproject.

6. Specifying a priority is useful if you are importing multiple netlist files, GCF files, or PDC, or SDC files. When importing multiple EDIF or structural HDL files, the top-level file must appear last in the list (at the bottom). Drag your files to specify the import order.

7. (IGLOO, ProASIC3, SmartFusion, Fusion, ProASIC<sup>PLUS</sup>, and Axcelerator designs only) Select [Merge PDC file\(s\) with existing physical constraints](#) to preserve all existing physical constraints that you have made using ChipPlanner, PinEditor, I/O Attribute Editor or a PDC file (imported previously).
8. (IGLOO, ProASIC3, SmartFusion, Fusion, ProASIC<sup>PLUS</sup>, and Axcelerator designs only) Select [Merge SDC file\(s\) with existing timing constraints](#) to preserve all the existing timing constraints already in your design, whether coming from the Timer tool or a previously imported file. If you import an SDC file and select this option, Designer merges the existing constraints and the constraints contained in the SDC file. In case of a conflict, the new constraint has priority over the existing constraint.
9. To set the audit options for these source files, click [Audit options](#) and follow the directions in the Audit Options dialog box.
10. When you are done adding all your source files, click **OK**. Your source files are imported. Any errors appear in the Designer log window.

**Note:** Note: Designer may not import file names or paths with spaces. Rename the file or path to remove the spaces, and re-import.

### See Also

[Auditing Files](#)

[import\\_aux](#)

[import\\_source](#)

[Importing auxiliary files](#)

## Importing Source Files – Copying Files Locally

Designer in Libero IDE cannot import files from outside your project without copying them to your local project folder. You may import source files from other locations, but they are always copied to your local folder. Designer in Libero IDE always audits the local file after you import; it does not audit the original file.

When the Project Manager asks you if you want to copy files "locally", it means 'copy the files to your local project folder'. If you do not wish to copy the files to your local project folder, you cannot import them. Your local project folder contains [files](#) related to your Libero IDE project.

Files copied to your local folders are copied directly into their relevant directory: netlists are copied to the *synthesis* folder; source files are copied to *hdl* folder and constraint files to *constraint* folder, etc. The files are also added to the Libero IDE project; they appear in the Files tab.

## Auditing Files

Designer audits your source files to ensure that your imported source files are current. All imported source files are date and time stamped. Designer notifies you if the file is changed. When notified, select the appropriate action and click **OK**.

**To change your audit settings:**

1. From the **File** menu, choose **Audit Settings**. The Audit Settings dialog box appears. Audit Timestamp reflects the last time and day that the import source or audit update was successfully done.
2. Select the **Audit** check box next to the file to enable auditing.
3. Click **Change Location** to open the Modify File Location dialog. The Modify File Location dialog box enables you to specify the correct path so that the design can find the source file(s).
4. Click **Reset to current date/time** to associate the file with the current day and time.

Libero IDE and Designer do not audit any CoreConsole generated files. If you regenerate a CoreConsole project you must re-import the configuration file.

**See Also**

[Audit Options dialog box](#)

[Auditing Status dialog box](#)

[Importing source files](#)

[import\\_source](#)

## Importing auxiliary files

Auxiliary files are not audited and are treated more as one-time data-entry or data-change events, similar to entering data using one of the interactive editors (e.g. PinEditor or Timer).

If you import the SDC file as an auxiliary, you do not have to re-compile your design. However, auditing is disabled when you import auxiliary files, and Designer cannot detect the changes to your SDC file(s) if you import them as auxiliary files.

Auxiliary Files	File Type Extension	Family
Criticality	*.crt	ACT1, ACT2, ACT3, MX, 1200XL, 3200DX
PIN	*.pin	ACT1, ACT2, ACT3, MX, 1200XL, 3200DX, SX, SX-A, eX
SDC	*.sdc	IGLOO, Fusion, ProASIC3, SX-A, eX, Axcelerator, ProASIC <sup>PLUS</sup>
Physical Design Constraint*	*.pdc	IGLOO, Fusion, ProASIC3 and Axcelerator
Value Change Dump	*.vcd	IGLOO, Fusion, ProASIC3, Axcelerator, ProASIC, ProASIC <sup>PLUS</sup>

Auxiliary Files	File Type Extension	Family
Switching Activity Intermediate File/Format	*.saif	IGLOO, Fusion, ProASIC3, Axcelerator, ProASIC, ProASIC <sup>PLUS</sup>
Design Constraint File	*.dcf	ACT1, ACT2, ACT3, MX, 1200XL, 3200DX, SX, SX-A, eX

**Note :** *Not all PDC commands are supported when a PDC file is imported as an auxiliary file; some must be imported as source files. When importing a PDC file as an auxiliary file, the new or modified PDC constraints are merged with the existing constraints. The software resolves any conflicts between new and existing physical constraints and displays the appropriate message. Most PDC commands can be imported as auxiliary files. PDC commands that are not supported when the PDC file is imported as an auxiliary file are noted in their respective help topics.*

**Note:** *Value Change Dump (VCD) files must be imported through SmartPower.*

**To import an auxiliary file (excluding VCD files):**

1. From the **File** menu, choose **Import Auxiliary Files**. The Import Auxiliary Files dialog appears,
2. Click the **Add** button. The Add Auxiliary Files dialog box appears.
3. Select your file and click **Import**. The file is added to the Import Auxiliary Files dialog box. Continue to add more auxiliary files to the list. Some formats (like DCF and SDC) are not allowed to be imported in multiple auxiliary files.
  - **Modifying:** If you need to modify a selection, select the file row and click **Modify**
  - **Deleting:** If you need to delete a file, select the file row and click **Delete**.
  - **Ordering:** Ordering your auxiliary files. Select and drag your files to specify the import order. Specifying a priority is useful if you are importing multiple PDC files.
4. After you are done adding all your Auxiliary files, click **OK**. Your auxiliary files are imported. Any errors appear in Designer's Log Window.

**Note:**

- VCD and SAIF are used by SmartPower for power analysis.
- CRT files are for backwards compatibility with existing designs only.
- File names or paths with spaces may not import into Designer. Rename the file or path, removing the spaces, and re-import.

## See Also

[Importing source files](#)

[import\\_aux](#)

[import\\_source](#)

[Keep existing timing constraints](#)

[Keep existing physical constraints](#)

## Merge SDC File(s) with Existing Timing Constraints

The Merge SDC file(s) with existing timing constraints checkbox is designed to support an additional “merge or replace” functionality when you import SDC files.

Select **Merge SDC file(s) with existing timing constraints**, to preserve all existing timing constraints that you have made using the Timer GUI or previously imported file. If you import a SDC file and you have this checkbox selected, Designer merges the existing constraints and the constraints existing in the SDC file. In case of a conflict, the new constraint has priority over the existing constraint.

The Merge SDC file(s) with existing timing constraints option is **On** by default. With this option **On**, your timing constraints from the imported SDC files are merged with the existing constraints. When this option is **Off**, all the existing timing constraints are replaced by the constraints in the newly imported SDC files.

### See Also

[import\\_aux](#)

[import\\_source](#)

## Merge PDC file(s) with existing physical constraints

The Merge PDC file(s) with existing physical constraints option in the Import Source Files dialog box enables you to merge or replace existing constraints when you import new or modified GCF or PDC files.

Select **Merge PDC file(s) with existing physical constraints** to preserve all existing physical constraints that you have entered either using one of the MVN tools (ChipPlanner, PinEditor, or the I/O Attribute Editor) or a previous GCF or PDC file. The software will resolve any conflicts between new and existing physical constraints and display the appropriate message.

The Merge PDC file(s) with existing physical constraints option is Off by default. When this option is Off, all the physical constraints in the newly imported GCF or PDC files are used. All pre-existing constraints are lost. When this option is On, the physical constraints from the newly imported GCF or PDC files are merged with the existing constraints.

### See Also

[Importing source files](#)

[import\\_source](#)

## Compiling your design

After you import your netlist files and select your device, you must compile your design. Compile contains a variety of functions that perform legality checking and basic netlist optimization. Compile checks for netlist errors (bad

connections and fan-out problems), removes unused logic (gobbling), and combines functions to reduce logic count and improve performance. Compile also verifies that the design fits into the selected device.

### There are three ways to select the compile command:

- In the Tools menu, select **Compile**.
- Click the **Compile** button in the Design Flow.
- Click the **Compile** icon in the toolbar.

If you have not already done so, Designer's [Device Selection Wizard](#) prompts you to set the device and package.

During compile, the message window in the Main window displays information about your design, including warnings and errors. Designer issues warnings when your design violates recommended Actel design rules. Actel recommends that you address all warnings, if possible, by modifying your design before you continue.

If the design fails to compile due to errors in your input files (netlist, constraints, etc.), you must modify the design to remove the errors. You must then re-import and re-compile the files.

After you compile the design, you can run Layout to place-and-route the design or use the User Tools (PinEditor, ChipEditor, ChipPlanner, Timer, SmartPower, or NetlistViewer) to perform additional optimization prior to place-and-route.

## Setting Compile Options

### To set compile options

1. From the **Options** menu, select **Compile**. The Compile Options dialog box opens. The Options available are family specific.
2. Select your options, and click **OK**.

**Note:** Note: Fusion, IGLOO and ProASIC3 Compile options appear by default each time you compile the design. If you have disabled this feature, you can click the Options menu and choose Compile to review/change/reset your Compile options.

### Compile options vary according to family.

- [IGLOO, Fusion, and ProASIC3](#)
- [ProASIC, ProASIC<sup>PLUS</sup>](#)
- [Axcelerator](#)
- [MX, SX, SX-A, eX](#)

## IGLOO, ProASIC3, SmartFusion and Fusion Compile Options

The IGLOO, Fusion and ProASIC3 Compile Options dialog box enables you to do the following:

- Set your [Block Instantiation](#) options (used for conflict resolution when you instantiate multiple blocks)

- Verify [Physical Design Constraints](#)
- Perform [Globals Management](#)
- [Netlist Optimization](#)
- Generate a [Compile report](#) in Display of Results
- Set [Block Creation](#) options (available only if you are creating a block)

## Block Instantiation

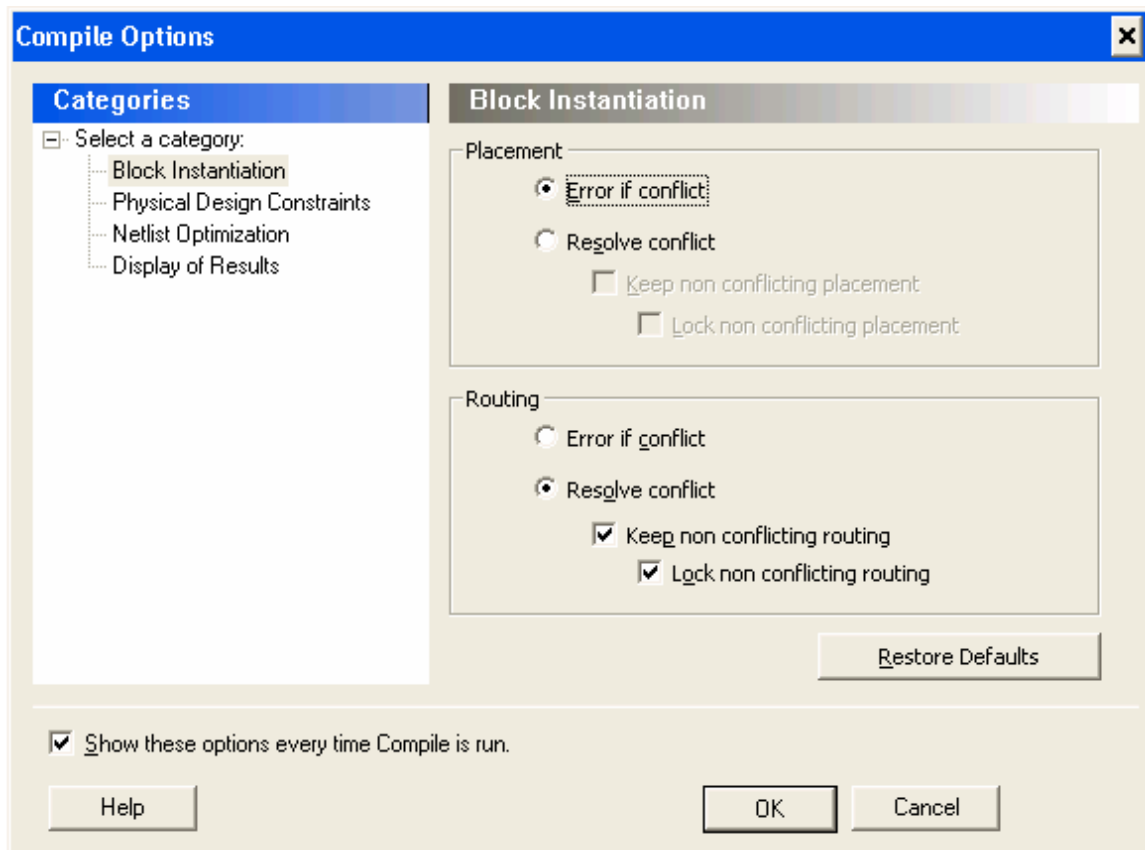

Designer uses the Block Instantiation options to resolve conflicts between multiple blocks in your design. The default options is to return an error if there is overlapping placement between the blocks and resolve any conflict for nets.

This ensures you are aware that the blocks overlap; you can go back and set the placement to resolve the conflicts and it will Compile.

See [Conflict resolution in Designer Blocks](#) for more information.

## Physical Design Constraints

This interface enables you to verify the Physical Design Constraints (PDC) file.

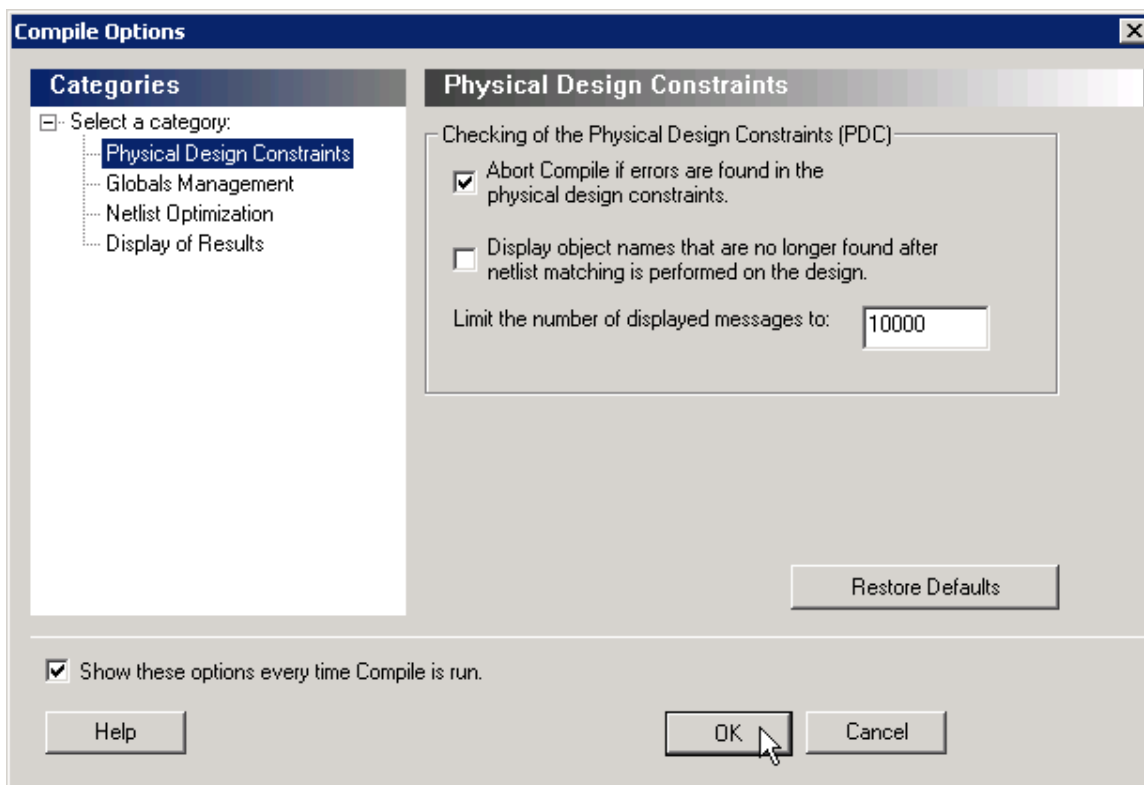

### Checking the Physical Design Constraint (PDC)

**Abort Compile if errors are found in the physical design constraints:** Changes the “Abort on PDC error” behavior. Select this option to stop the flow if any error is reported in reading your PDC file. If you deselect this option, the tool skips errors in reading your PDC file and just reports them as warnings. The default is ON.

**Note:** Note: The flow always stops even if this option is deselected in the following two cases:

- If there is a Tcl error (For example, the command does not exist or the syntax of the command is incorrect)
- The `assign_local_clock` command for assigning nets to LocalClocks fails. This may happen if any floor planning DRC check fails, such as, region resource check, fix macro check (one of the load on the net is outside the local clock region). If such an error occurs, then the Compile command fails. Correct your PDC file to proceed.

**Note:** Note: Every time you invoke this dialog box, this option is reset to its default value ON. This is to ensure that you have a correct PDC file.

**Display object names that are no longer found after netlist matching is performed on the design:** Displays netlist objects in the PDC that are not found in the imported netlist during the Compile ECO mode. Select this option to report netlist objects not found in the current netlist when reading the internal ECO PDC constraints. The default is OFF.

**Limit the number of displayed messages to:** Defines the maximum number of errors/warnings to be displayed in the case of reading ECO constraints. The default is 10000 messages.



## Globals Management

The interface provides a global control to the Compile component of the design flow.

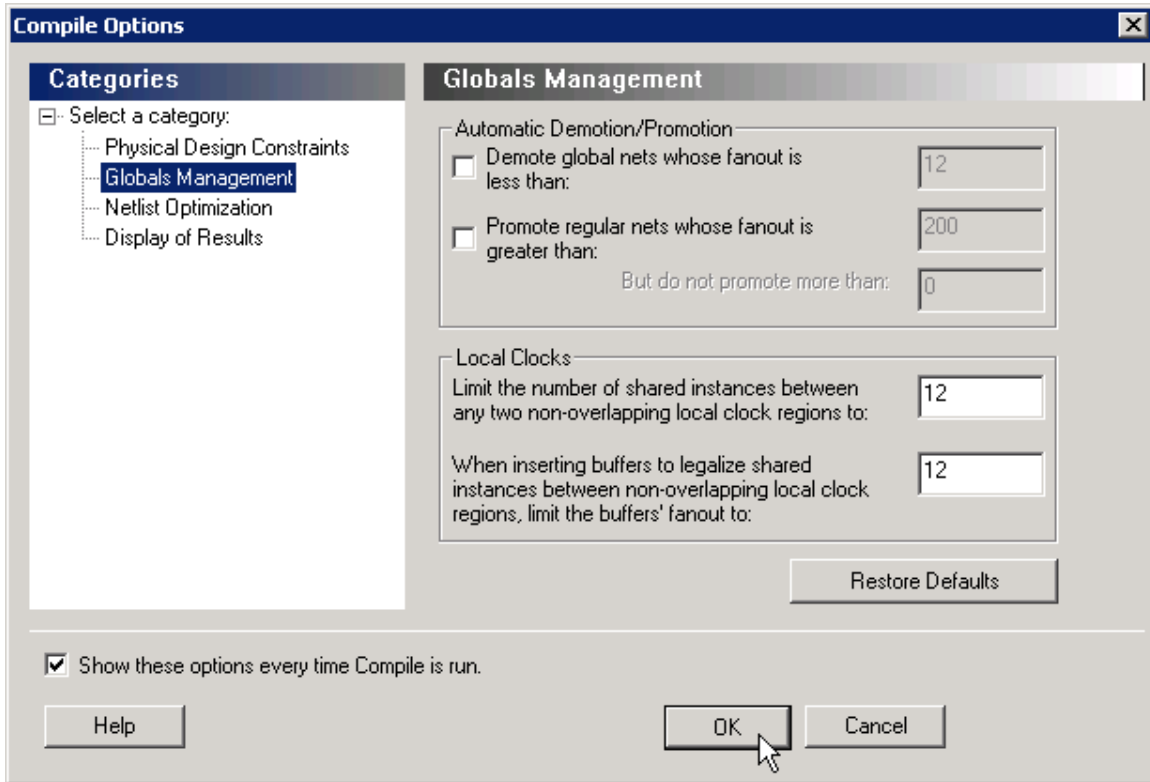

### Automatic Demotion/Promotion

**Demote global nets whose fanout is less than:** Enables the global clock demotion of global nets to regular nets. By default, this option is OFF. The maximum fanout of a demoted net is 12.

**Note:** Note: A global net is not automatically demoted (assuming the option is selected) if the resulting fanout of the demoted net is greater than the max fanout value. Actel recommends that the automatic global demotion only act on small fanout nets. Actel recommends that you drive high fanout nets with a clock network in the design to improve timing and routability.

**Promote regular nets whose fanout is greater than:** Enables global clock promotion of nets to global clock network. By default, this option is OFF. The minimum fanout of a promoted net is 200.

**But do not promote more than:** Defines the maximum number of nets to be automatically promoted to global. The default value is 0. This is not the total number as nets need to satisfy the minimum fanout constraint to be promoted. The `promote_globals_max_limit` value does not include globals that may have come from either the netlist or PDC file (quadrant clock assignment or global promotion).

**Note:** Note: Demotion of globals through PDC or Compile is done before automatic global promotion is done.

**Note:** You may exceed the number of globals present in the device if you have nets already assigned to globals or quadrants from the netlist or by using a PDC file. The automatic global promotion adds globals on what already exists in the design.

### Local clocks

**Limit the number of shared instances between any two non-overlapping local clock regions to:** Defines the maximum number of shared instances allowed to perform the legalization. It is also for quadrant clocks.

The maximum number of instances allowed to be shared by 2 local clock nets assigned to disjoint regions to perform the legalization (default is 12, range is 0-1000). If the number of shared instances is set to 0, no legalization is performed.

**When inserting buffers to legalize shared instances between non-overlapping local clock regions, limit the buffers' fanout to:** Defines the maximum fanout value used during buffer insertion for clock legalization. Set the value to 0 to disable this option and prevent legalization (default value is 12, range is 0-1000). If the value is set to 0, no buffer insertion is performed. If the value is set to 1, there will be one buffer inserted per pin.

**Note:** Note: If you assign quadrant clock to nets using MultiView Navigator, no legalization is performed.

## Netlist Optimization

This interface allows you to perform netlist optimization.

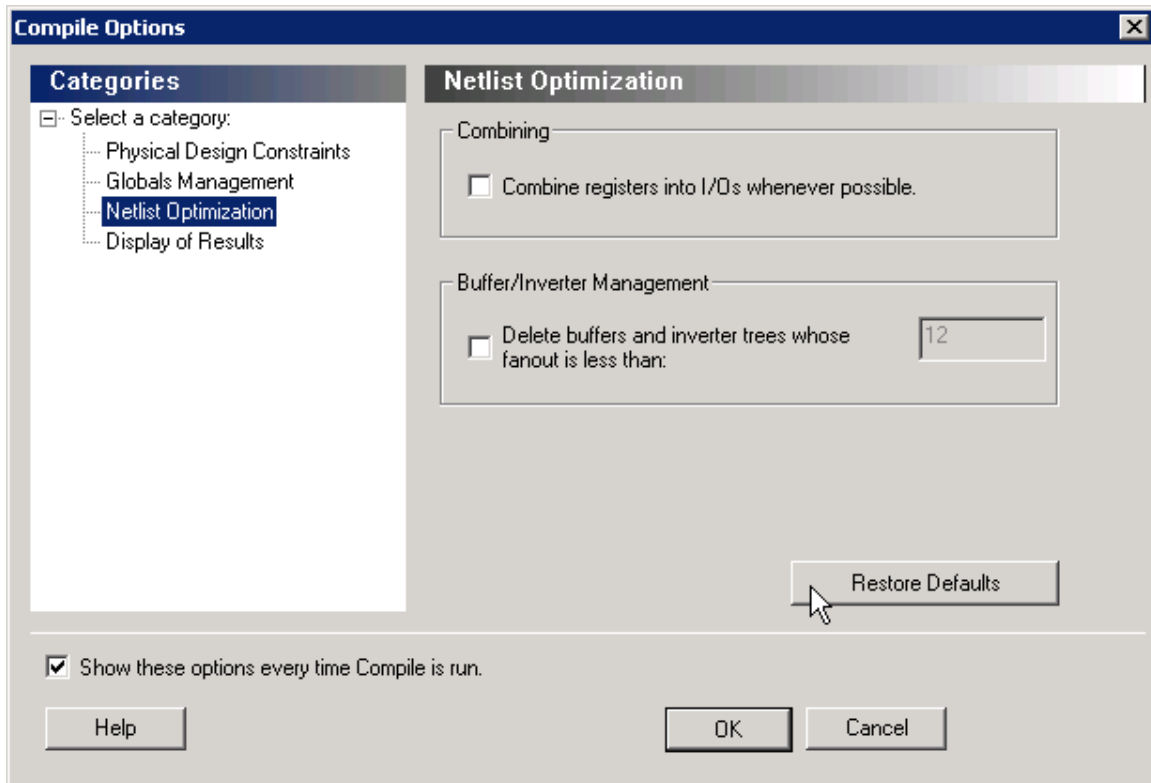

### Combining

Combine registers into I/O wherever possible: Combines registers at the I/O into I/O-Registers. Select this option for optimization to take effect. By default, this option is OFF.

### Buffer/Inverter Management

Delete buffers and inverter trees whose fanout is less than: Enables buffer tree deletion on the global signals from the netlist. The buffer and inverter are deleted. By default, this option is OFF. The maximum fanout of a net after buffer tree deletion is 12.

**Note:** Note: A net does not automatically remove its buffer tree (assuming the option is on) if the resulting fanout of the net (if the buffer tree was removed) is greater than the max fanout value. Actel recommends that the automatic buffer tree deletion should only act on small fanout nets. From a routability and timing point of view, it is not recommended to have high fanout nets not driven by a clock network in the design.

## Display of Results

This interface lets you generate a Compile report.

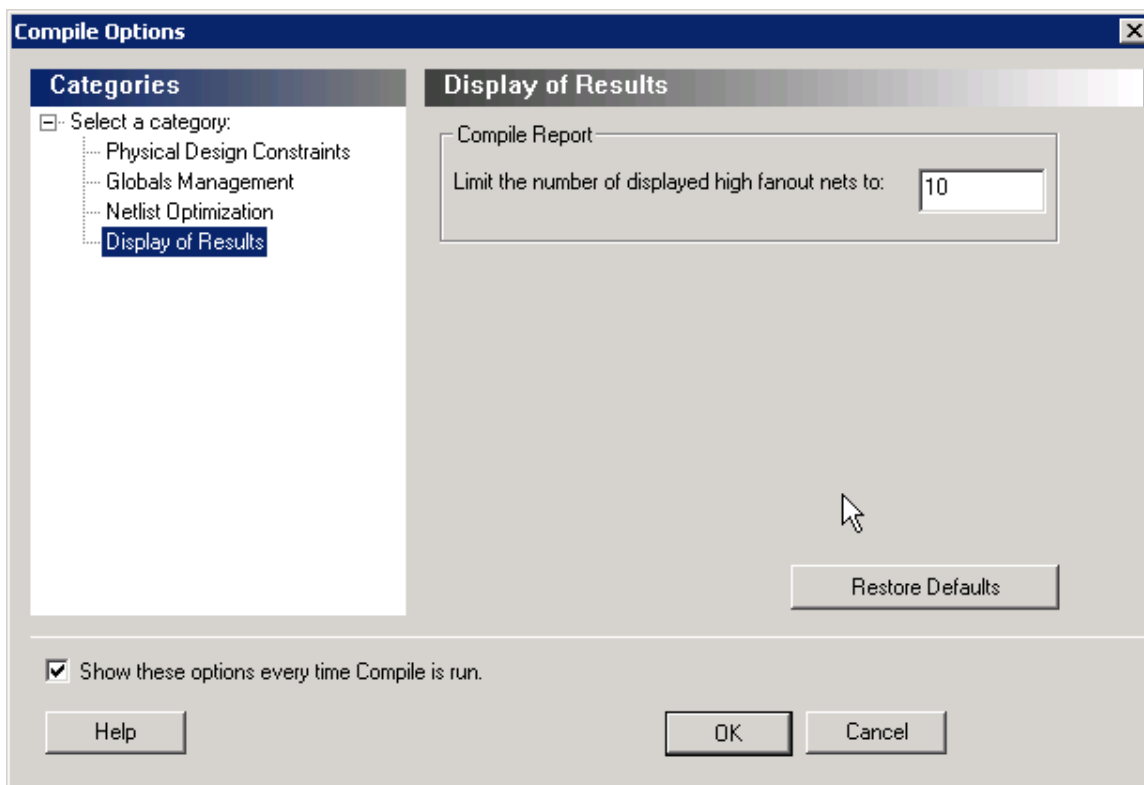

### Compile Report

**Limit the number of displayed high fanout nets to:** Enables flip-flop net sections in the compile report and defines the number of nets to be displayed in the high fanout. The default value is 10.

## Block Creation (Available only when creating Designer Blocks)

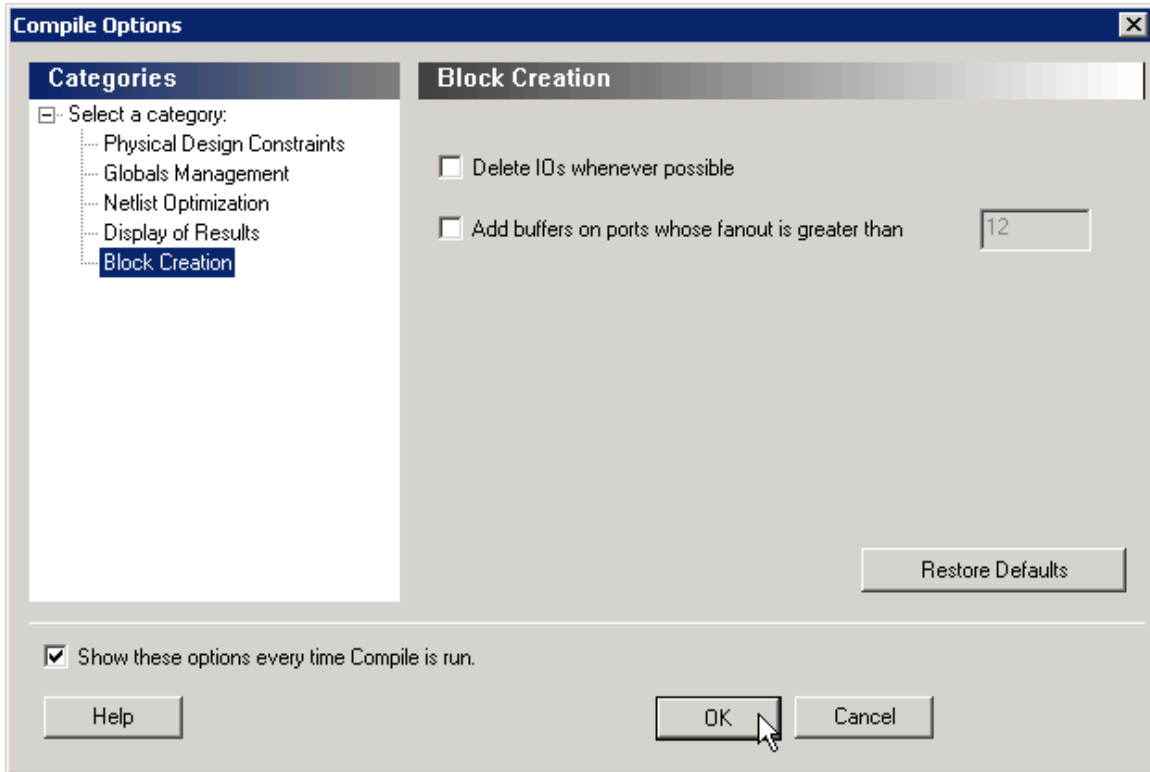

**Delete I/Os whenever possible** - Deletes I/Os in the block during compile (except TRIBUFF and BIBUFF, because they cannot be removed). Useful if you have I/Os in your design but want to create a block anyway.

**Add buffers on ports whose fanout is greater than <value>** - Adds buffers on ports with a fanout greater than a value you specify. This option enables more predictable block timing. For example, if you have a net with a fanout of 100 the net will be unrouted. If you add a buffer, the output of the buffer is routed and the routing is preserved.

### See Also

[compile](#)

## ProASIC and ProASIC<sup>PLUS</sup> Compile Options

### Include RAM and I/O in Spine and Net Regions

This option affects the behavior of the following:

- The use\_global constraint
- The set\_net\_region constraint
- The creation of spines in the MultiView Navigator

Selecting **Include RAM and I/O in Spine and Net Regions** enables you to assign memory and I/O to spine (LocalClock) and net regions.

When this option is selected, Designer applies the `use_global` and `set_net_region` constraints to core cells, memory, and I/O. When cleared, Designer applies the `use_global` and `set_net_region` constraints to core cells only. For new designs, this box is automatically checked. For designs created with v5.1 or earlier, this option is cleared by default. If you change this default setting, you must recompile your design.

This option also determines whether memory and I/O are included in a LocalClock region that you create with the ChipPlanner tool. If selected, memory and I/O are included. If cleared, they are excluded.

## Axcelerator Compile Options

The Axcelerator Compile Options dialog box enables you to do the following:

- Set your [Block Instantiation](#) options (used for conflict resolution when you instantiate multiple blocks)
- Verify [Physical Design Constraints](#)
- [Netlist Optimization](#)
- Generate a [Compile report](#) in Display of Results
- Set [Block Creation](#) options (available only if you are creating a block)

## Block Instantiation

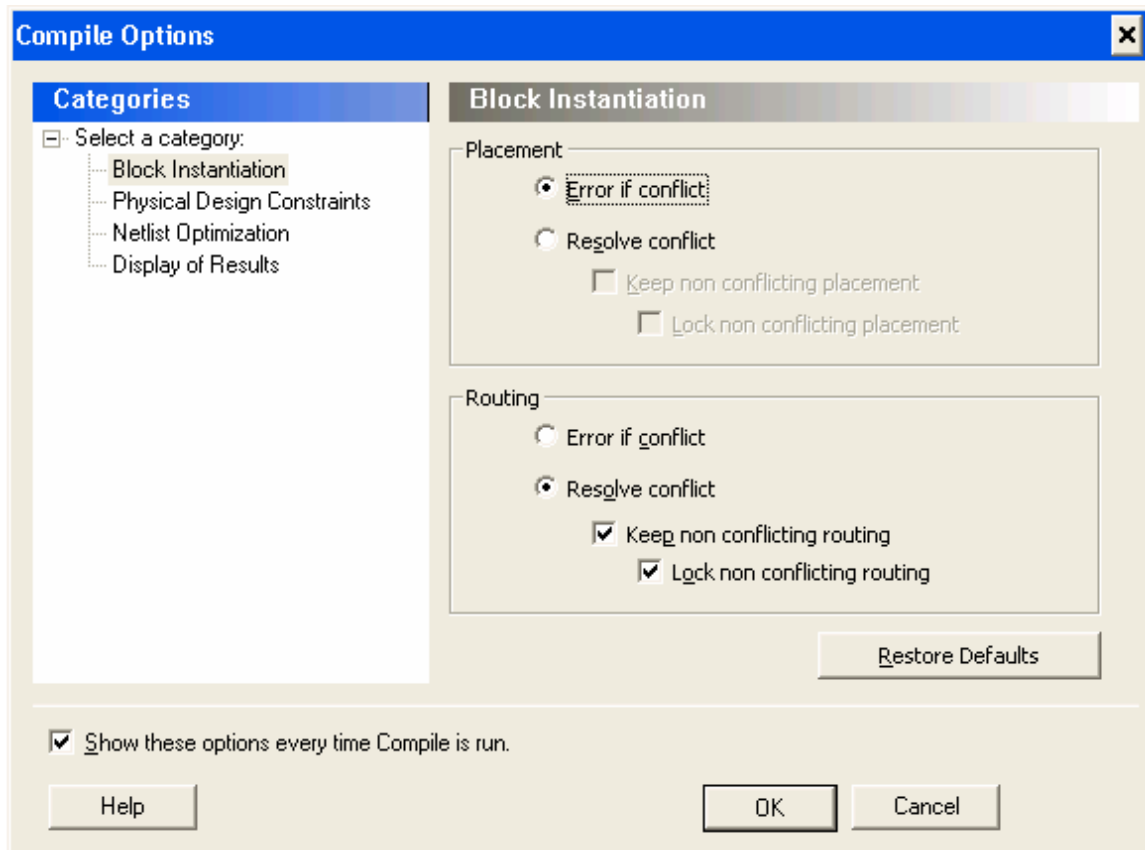

Designer uses the Block Instantiation options to resolve conflicts between multiple blocks in your design. The default options is to return an error if there is overlapping placement between the blocks and resolve any conflict for nets.

This ensures you are aware that the blocks overlap; you can go back and set the placement to resolve the conflicts and it will Compile.

See [Conflict resolution in Designer Blocks](#) for more information.

## Physical Design Constraints

This interface enables you to verify the Physical Design Constraints (PDC) file.

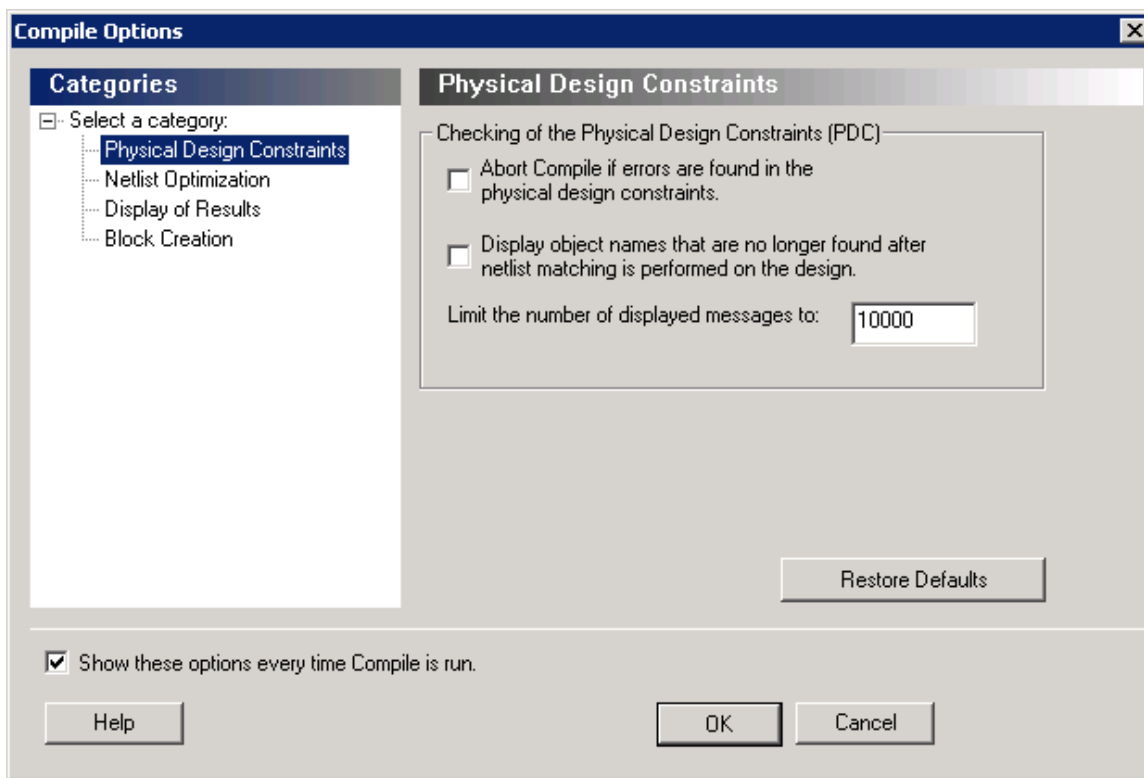

### Checking the Physical Design Constraint (PDC)

**Abort Compile if errors are found in the physical design constraints:** Changes the “Abort on PDC error” behavior. Select this option to stop the flow if any error is reported in reading your PDC file. If you deselect this option, the tool skips errors in reading your PDC file and just reports them as warnings. The default is ON.

**Note:** Note: The flow always stops even if this option is deselected in the following two cases:

- If there is a Tcl error (For example, the command does not exist or the syntax of the command is incorrect)
- The `assign_local_clock` command for assigning nets to LocalClocks fails. This may happen if any floor planning DRC check fails, such as, region resource check, fix macro check (one of the load on the net is outside the local clock region). If such an error occurs, then the Compile command fails. Correct your PDC file to proceed.

**Note:** Note: Every time you invoke this dialog box, this option is reset to its default value ON. This is to ensure that you have a valid PDC file.

**Display object names that are no longer found after netlist matching is performed on the design:** Displays netlist objects in the PDC that are not found in the imported netlist during the Compile ECO mode. Select this option to report netlist objects not found in the current netlist when reading the internal ECO PDC constraints. The default is OFF.

**Limit the number of displayed messages to:** Defines the maximum number of errors/warnings to be displayed in the case of reading ECO constraints. The default is 10000 messages.



## Netlist Optimization

This interface allows you to perform netlist optimization.

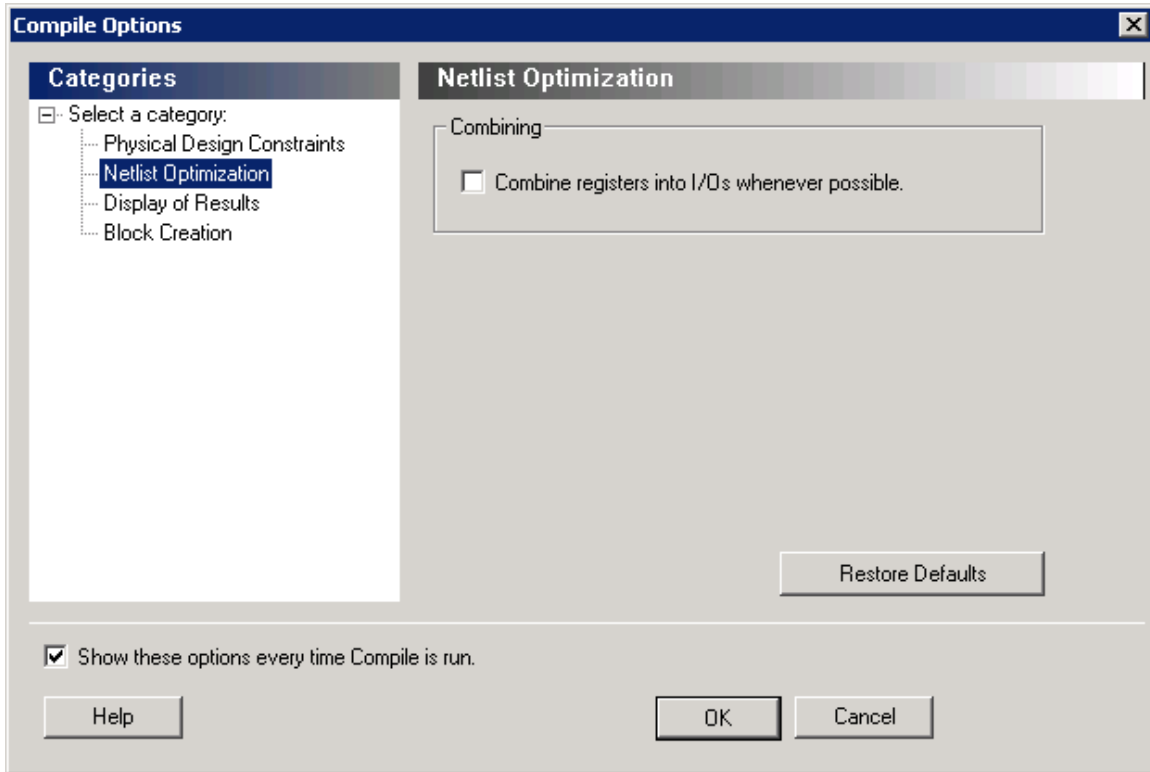

### Combining

**Combine registers into I/O wherever possible:** Combines registers at the I/O into I/O-Registers. Select this option for optimization to take effect. By default, this option is OFF.

### Buffer/Inverter Management

**Delete buffers and inverter trees whose fanout is less than:** Enables buffer tree deletion on the global signals from the netlist. The buffer and inverter are deleted. By default, this option is OFF. The maximum fanout of a net after buffer tree deletion is 12.

**Note:** Note: A net does not automatically remove its buffer tree (assuming the option is on) if the resulting fanout of the net (if the buffer tree was removed) is greater than the max fanout value. Actel recommends that the automatic buffer tree deletion should only act on small fanout nets. From a routability and timing point of view, it is not recommended to have high fanout nets not driven by a clock network in the design.

## Display of Results

This interface lets you generate a Compile report.

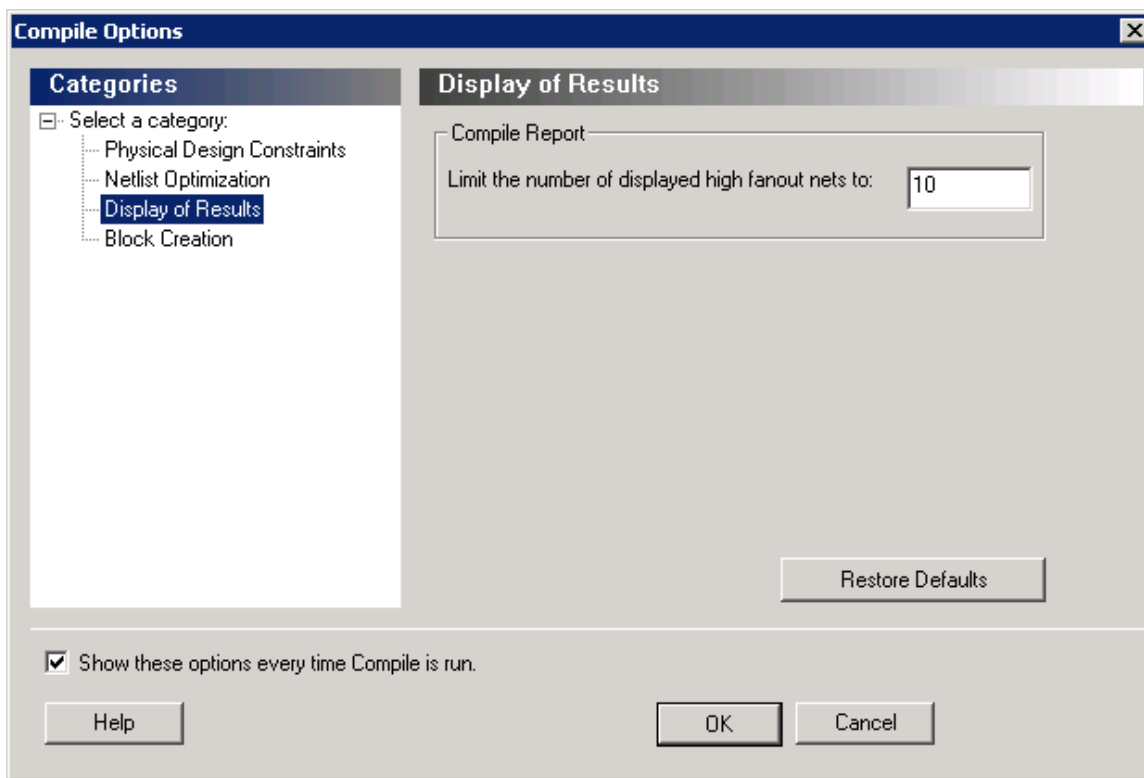

### Compile Report

**Limit the number of displayed high fanout nets to:** Enables flip-flop net sections in the compile report and defines the number of nets to be displayed in the high fanout. The default value is 10.

## Block Creation (available only when creating Designer Blocks)

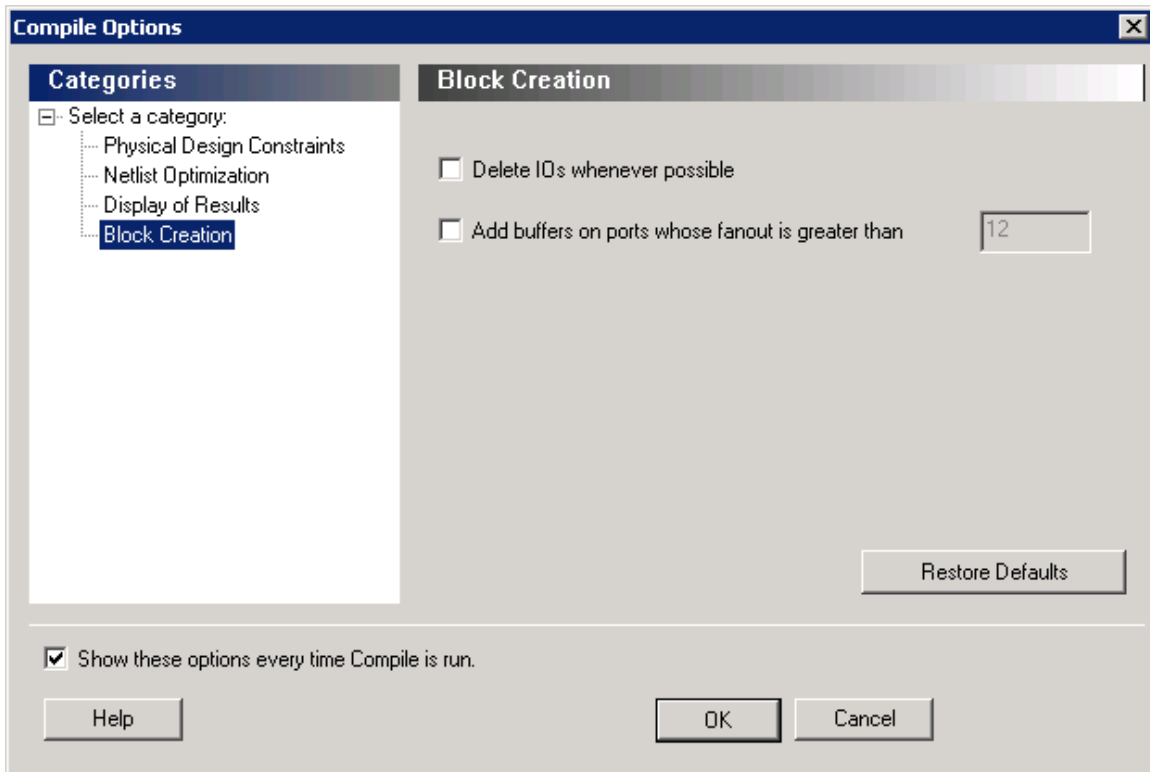

**Delete I/Os whenever possible** - Deletes I/Os in the block during compile (except TRIBUFF and BIBUFF, because they cannot be removed). Useful if you have I/O's in your design but want to create a block anyway.

**Add buffers on ports whose fanout is greater than <value>** - Adds buffers on ports with a fanout greater than a value you specify. This option enables more predictable block timing. For example, if you have a net with a fanout of 100 the net will be unrouted. If you add a buffer, the output of the buffer is routed and the routing is preserved.

### See Also

[compile](#)

## MX, SX, SX-A, eX Compile Options

### Netlist Pin Properties Overwrite Existing Properties

During the Compile process, Designer checks the netlist properties. If the netlist file specifies a pin assignment for a pin that was also assigned in PinEditor session, there is a conflict. How this conflict is resolved is determined by your selection in this check box.

If this option is **Off**, or cleared, then Designer uses the assignment made in PinEditor, and the assignment in the netlist file for the conflicting pin is ignored. If this option is **On**, or selected, then Designer uses the assignment in the

netlist file for that pin, and the PinEditor assignment is ignored. If you edit pin assignments in PinEditor, this option is automatically set to **Off**.

## Fanout messages

Use the control slider in the Messages area to control the warning level. Use the control slider to specify the fanout limit that the Compile step checks against. Setting the control slider to '0' informs the system to use the system defaults. Any non-zero value replaces the system default value for the fanout limit with the user-specified value. Typically, this value range is 1 to 24.

This does not adjust the fanout of the design and it has no effect on the netlist. This only adjusts the warning level by controlling what level of fanout checking you want to be warned about during Compile. Changing this fanout limit option does not invalidate the Compile design state.

# Design Constraints

Design constraints are usually either requirements or properties in your design. You use constraints to ensure that your design meets its performance goals and pin assignment requirements.

The Designer software supports both timing and physical constraints. In addition, it supports netlist optimization constraints. You can set constraints by either using Actel's interactive tools or by importing constraint files directly into your design session.

## Timing Constraints

Timing constraints represent the performance goals for your designs. Designer software uses timing constraints to guide the timing-driven optimization tools in order to meet these goals.

You can set timing constraints either globally or to a specific set of paths in your design.

You can apply timing constraints to:

- Specify the required minimum speed of a clock domain
- Set the input and output port timing information
- Define the maximum delay for a specific path
- Identify paths that are considered false and excluded from the analysis
- Identify paths that require more than one clock cycle to propagate the data
- Provide the external load at a specific port

To get the most effective results from the Designer software, you need to set the timing constraints close to your design goals. Sometimes slightly tightening the timing constraint helps the optimization process to meet the original specifications.

## Physical Constraints

Designer software enables you to specify the physical constraints to define the size, shape, utilization, and pin/pad placement of a design. You can specify these constraints based on the utilization, aspect ratio, and dimensions of the die. The pin/pad placement depends on the external physical environment of the design, such as the placement of the device on the board.

There are three types of physical constraints:

- I/O assignments
  - Set location, attributes, and technologies for I/O ports
  - Specify special assignments, such as VREF pins and I/O banks
- Location and region assignments

- Set the location of Core, RAM, and FIFO macros
- Create Regions for I/O and Core macros as well as modify those regions
  - Clock assignments
- Assign nets to clocks
- Assign global clock constraints to global, quadrant, and local clock resources

## Netlist Optimization Constraints

The Designer software enables you to set some advanced design-specific netlist optimizing constraints.

You can apply netlist optimization constraints to:

- Delete or restore a buffer tree
- Manage the fan-outs of the nets
- Manage macro combinations (for example, IO-REG combining)
- Optimize a netlist by removing buffers and/or inverters, propagating constants, and so on

### See Also

[Constraint Support by Family](#)

[Constraint Entry Table](#)

[Constraint File Format by Family](#)

[Designer Naming Conventions](#)

## Constraint Entry

Use the Constraint Entry table to see which tools and file formats you can use to enter constraints for your device family.

Click the name of a constraint, a constraint entry tool, file format type, editor, or checkmark in the table for more information about that item.

Table 4 · Constraint Entry by Tool and File Format

Constraint	SDC	GCF	PDC	PIN	DCF	ChipPlanner	I/O Attribute Editor	PinEditor	SmartTime/Timer	Compile Options
<b>Timing</b>										
<a href="#">Create a clock</a>	X				X				X	
<a href="#">Create a generated clock</a>	X								X	
<a href="#">Remove clock uncertainty</a>	X								X	
<a href="#">Set clock latency</a>	X								X	
<a href="#">Set clock uncertainty</a>	X								X	
<a href="#">Set disable timing</a>	X								X	
<a href="#">Set false path</a>	X				X				X	
<a href="#">Set input delay</a>	X								X	
<a href="#">Set load on output port</a>	X				X		X	X	X	

Design Constraints

Constraint	SDC	GCF	PDC	PIN	DCF	ChipPlanner	I/O Attribute Editor	PinEditor	SmartTime/Timer	Compile Options
<b>Timing</b>										
<a href="#">Set maximum delay</a>	X				X				X	
<a href="#">Set minimum delay</a>	X								X	
<a href="#">Set multicycle path</a>	X								X	
<a href="#">Set output delay</a>	X								X	
<b>Physical Placement</b>										
<b>-Clocks</b>										
<a href="#">Assign Net to Global Clock</a>		X	X							
<a href="#">Assign Net to Local Clock</a>		X	X			X				
<a href="#">Assign Net to Quadrant Clock</a>			X			X				
<b>-Regions</b>										
<a href="#">Assign Macro to Region</a>			X			X				



Constraint	SDC	GCF	PDC	PIN	DCF	ChipPlanner	I/O Attribute Editor	PinEditor	SmartTime/Timer	Compile Options
<b>Timing</b>										
<a href="#">Assign Net to Region</a>		X	X			X				
<a href="#">Create Region</a>		X	X			X				
<a href="#">Delete Regions</a>			X			X				
<a href="#">Move region</a>			X			X				
<a href="#">Unassign macro(s) driven by net</a>			X			X				
<a href="#">Unassign macro from region</a>			X			X				
<b>-I/Os</b>										
<a href="#">Assign I/O to pin</a>		X	X	X		X	X	X		
<a href="#">Assign I/O Macro to Location</a>		X	X			X				
<a href="#">Configure I/O Bank</a>			X			X		X		
<a href="#">Reset attributes on I/O to</a>			X			X	X			

Design Constraints

Constraint	SDC	GCF	PDC	PIN	DCF	ChipPlanner	I/O Attribute Editor	PinEditor	SmartTime/Timer	Compile Options
<b>Timing</b>										
<a href="#">default settings</a>										
<a href="#">Reset I/O bank to default settings</a>			X			X	X			
<a href="#">Reserve pins</a>			X				X	X		
<a href="#">Unreserve pins</a>			X				X	X		
<a href="#">Unassign I/O macro from location</a>			X			X				
<b>-Blocks</b>										
<a href="#">Move Block</a>			X							
<a href="#">Set port block</a>			X			X				
<a href="#">Set Block Options</a>			X							X
<b>-Nets</b>										
<a href="#">Assign Net to Global Clock</a>		X	X							
<a href="#">Assign Net to Local</a>		X	X			X				

Constraint	SDC	GCF	PDC	PIN	DCF	ChipPlanner	I/O Attribute Editor	PinEditor	SmartTime/Timer	Compile Options
<b>Timing</b>										
<a href="#">Clock</a>										
<a href="#">Assign Net to Quadrant Clock</a>			X			X				
<a href="#">Assign Net to Region</a>		X	X			X				
<a href="#">Reset net's criticality to default level</a>			X							
<a href="#">Set Net's Criticality</a>		X	X							
<a href="#">Unassign macro(s) driven by net</a>			X			X				
<b>Netlist Optimization</b>										
<a href="#">Delete buffer tree</a>		X	X							X
<a href="#">Demote Global Net to Regular Net</a>		X	X							X
<a href="#">Promote regular net to global net</a>		X	X							X

Constraint	SDC	GCF	PDC	PIN	DCF	ChipPlanner	I/O Attribute Editor	PinEditor	SmartTime/Timer	Compile Options
<b>Timing</b>										
<a href="#">Restore buffer tree</a>		X	X							
<a href="#">Set preserve</a>			X							

**See Also**

[Constraint Support by Family](#)

[Constraint File Format by Family](#)

---

## **Families Supported**

## Constraint Support by Family

Use the Constraint Family Support table to see which constraints you can use for your device family. Click the name of a constraint in the table for more information about it.

Table 5 · Constraint Support by Family

	IGLOO	SmartFusion and Fusion	ProASIC3	ProASIC <sup>Plus</sup>	ProASIC	Accelerator	eX	SX-A	SX	MX	DX	ACT1	ACt2/1200XL	ACT3
<b>Timing</b>														
<a href="#">Create a clock</a>	X	X	X	X	X	X	X	X	X	X	X	X	X	X
<a href="#">Create a generated clock</a>	X	X	X	X	X	X	X	X						
<a href="#">Remove clock uncertainty</a>	X	X	X	X	X	X	X	X						
<a href="#">Set clock latency</a>	X	X	X	X	X	X	X	X						
<a href="#">Set clock uncertainty</a>	X	X	X	X	X	X	X	X						
<a href="#">Set disable timing</a>	X	X	X			X (including RTAX-S)							X	X
<a href="#">Set false path</a>	X	X	X	X	X	X	X	X	X	X	X	X	X	X
<a href="#">Set input delay</a>	X	X	X	X		X								
<a href="#">Set load on output port</a>	X	X	X	X	X	X	X	X						
<a href="#">Set maximum delay</a>	X	X	X	X	X	X	X	X	X	X	X	X	X	X
<a href="#">Set minimum delay</a>	X	X	X	X	X	X	X	X	X	X	X	X	X	X
<a href="#">Set multicycle path</a>	X	X	X	X		X								
<a href="#">Set output delay</a>	X	X	X	X		X								
<b>Physical Placement</b>														

-Clocks														
<a href="#">Assign Net to Global Clock</a>	X	X	X	X	X									
<a href="#">Assign Net to Local Clock</a>	X	X	X	X	X	X								
<a href="#">Assign Net to Quadrant Clock</a>	X	X	X											
-Regions														
<a href="#">Assign Macro to Region</a>	X	X	X	X	X	X								
<a href="#">Assign Net to Region</a>	X	X	X	X	X	X								
<a href="#">Create Region</a>	X	X	X	X	X	X								
<a href="#">Delete Regions</a>	X	X	X	X	X	X								
<a href="#">Move Region</a>	X	X	X	X	X	X								
<a href="#">Unassign macro(s) driven by net</a>	X	X	X	X	X	X								
<a href="#">Unassign Macro from Region</a>	X	X	X	X	X	X								
-I/Os														
<a href="#">Assign I/O to pin</a>	X	X	X	X	X	X	X	X	X	X	X	X	X	X
<a href="#">Assign I/O Macro to Location</a>	X	X	X	X	X	X								
<a href="#">Configure I/O Bank</a>	X	X	X			X								
<a href="#">Reset attributes on I/O to default settings</a>	X	X	X	X	X	X								
<a href="#">Reset I/O bank to default settings</a>	X	X	X			X								
<a href="#">Reserve pins</a>	X	X	X	X	X	X	X							
<a href="#">Unreserve pins</a>	X	X	X	X	X	X	X							
<a href="#">Unassign I/O macro from location</a>	X	X	X	X	X	X								
-Block														

Families Supported

	IGLOO	SmartFusion and Fusion	ProASIC3	ProASIC <sup>Plus</sup>	ProASIC	Accelerator	eX	SX-A	SX	MX	DX	ACT1	ACT2/1200XL	ACT3
<b>Timing</b>														
<a href="#">Move Block</a>	X	X	X			X								
<a href="#">Set port block</a>	X	X	X			X								
<a href="#">Set Block Options</a>	X	X	X			X								
<b>-Nets</b>														
<a href="#">Assign Net to Global Clock</a>	X	X	X	X	X									
<a href="#">Assign Net to Local Clock</a>	X	X	X	X	X	X								
<a href="#">Assign Net to Quadrant Clock</a>	X	X	X											
<a href="#">Assign Net to Region</a>	X	X	X	X	X	X								
<a href="#">Reset net's criticality to default level</a>						X								
<a href="#">Set Net's Criticality</a>						X								
<a href="#">Unassign macro(s) driven by net</a>	X	X	X	X		X								
<b>Netlist Optimization</b>														
<a href="#">Delete buffer tree</a>	X	X	X											
<a href="#">Demote Global Net to Regular Net</a>	X	X	X	X	X									
<a href="#">Promote regular net to global net</a>	X	X	X	X	X									
<a href="#">Restore buffer tree</a>	X	X	X	X	X									
<a href="#">Set preserve</a>	X	X	X			X								



**See Also**

[Constraint Entry Table](#)

[Constraint File Format by Family](#)

## Constraint File Format by Family

Use the File Format by Family table to see which file formats apply to each type of constraint and each device family.

Table 6 · Constraint File Format by Family

Family	Timing		Physical Placement			Netlist Optimization	
	SDC	DCF	PDC	PIN	GCF	PDC	GCF
IGLOO	X		X				
SmartFusion / Fusion	X		X			X	
ProASIC3	X		X				
ProASIC <sup>PLUS</sup>	X				X		X
ProASIC	X				X		X
Axcelerator	X		X			X	
eX	X	X		X			
SX-A	X	X		X			
SX		X		X			
MX		X		X			
DX		X		X			
ACT3		X		X			
ACT2/1200XL		X		X			
ACT1		X		X			

SDC – Synopsys Design Constraints

PDC – Physical Design Constraints for IGLOO, ProASIC3, SmartFusion, Fusion, and Axcelerator

GCF – Design Constraints Format for ProASIC<sup>PLUS</sup> and ProASIC

DCF – Actel Design Constraints Format

PIN – Pin location constraints

**See Also**

[Constraint Support by Family](#)

[Constraint Entry Table](#)

# Entering Constraints

You can enter design constraints in the following ways:

- **Importing constraint files:** You can import GCF, PDC, SDC, DCF, or PIN constraint files. The type of file you use depends on which type of device you are designing.
  - GCF (ProASIC and ProASIC<sup>PLUS</sup> families)
  - PDC (IGLOO, ProASIC3, SmartFusion, Fusion, and Axcelerator families)
  - SDC (IGLOO, ProASIC3, SmartFusion, Fusion, Axcelerator, RTAX-S, eX, and SX-A families)
  - DCF (earlier Antifuse families such as eX, SX-A, and SX)
  - PIN (only valid for earlier Antifuse families such as eX, SX-A, and SX)
- **Using constraint editor tools:** Designer's constraint editors are graphical user interface (GUI) tools for creating and modifying physical, logical, and timing constraints. Using these tools enables you to enter constraints without having to understand GCF, PDC, or other file syntax. Which constraint editor you use depends on which type of device you are designing.

For **IGLOO, ProASIC3, SmartFusion, Fusion, ProASIC<sup>PLUS</sup>, ProASIC, and Axcelerator**, use the tools within the MultiView Navigator:

- ChipPlanner - Sets location and region assignments
- PinEditor in MVN - Sets the pin location constraints
- I/O Attribute Editor - Sets I/O attributes
- [SmartTime Constraints Editor](#) SmartTime Constraints Editor - Enables you to view and edit timing constraints

For all other families, you will use the following tools:

- ChipEditor - Sets location and region assignments
- PinEditor (non MVN)- Sets I/O attributes and pin location constraints
- Timer - Sets timing constraints

## See Also

[Constraint Support by Family](#)

[Constraint Entry](#)

[Constraint File Format by Family](#)

[Designer Naming Conventions](#)

# Running Layout

Use Layout to place and route your design.

## To run Layout:

1. Click the **Layout** button in the Design Flow Window.

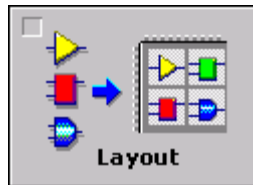

2. **Layout Options.** Select your Layout options and Click **OK**. Layout options are family specific:

- [IGLOO, Fusion, and ProASIC3 Layout Options](#)
- [ProASICPLUS and ProASIC Layout Options](#)
- [Axcelerator Layout Options](#)
- [eX, SX, and SX-A Layout Options](#)
- [ACT, MX, and DX Layout Options](#)

## IGLOO, ProASIC3, SmartFusion and Fusion Layout Options

When [running layout](#), use the Layout Options dialog box to set your layout options.

The I/O Bank Assigner and Global Planner run automatically after you click **OK** in the **Layout Options** dialog box.

The I/O Bank Assigner automatically assigns technologies to all I/O banks that have not been assigned a technology.

The Global Planner automatically assigns global nets to clock conditioning circuit (CCC) locations on the chip in the design.

**Note:** Note: All I/O technologies assigned to I/O banks by the I/O Bank Assigner in Layout are unlocked.

## Timing-Driven

Select this option to run Timing-Driven Layout. The primary goal of timing-driven layout is to meet timing constraints, specified by you or generated automatically. Timing-driven Layout typically delivers better performance than Standard layout.

If you do not select Timing-driven layout, Designer runs Standard layout. Standard layout targets efficient usage of the chip resources. Chip performance is not optimized. Timing constraints are not considered by the Layout in standard mode, although a delay report based on delay constraints entered in Timer can still be generated for the design. This is helpful to determine if timing-driven Layout is required.

If your design has multiple scenarios, you can select a scenario from the pull-down list to perform timing driven layout.

### Power-Driven

Select this option to run Power-Driven Layout. The primary goal of power-driven layout is to reduce dynamic power while still maintaining timing constraints.

To get the most out of Power-Driven Layout, it is recommended to:

1. Enter maximum delay, minimum delay, setup, and hold constraints in SmartTime's constraint editor or in SDC.
2. Set false paths on any paths that have a constraint, but do not need one (this will help layout meet the constraints that are needed).
3. Perform Layout with **Timing-Driven**, **Run Place**, and **Run Route** options checked.
4. Resolve worst case setup and maximum delay violations.
5. Generate an SDF back-annotation file.
6. Perform a post layout back-annotated simulation using this SDF file, and export a [VCD](#) (Value Change Dump) file that will capture real activities for each net.
7. [Import this VCD](#) file in Designer using the **Import Auxiliary** option from the **File** menu.
8. Perform Layout with **Timing-Driven** and **Power-Driven** checked. Run Place and Route.
9. Verify that your timing constraints are still met with SmartTime.
10. Analyze your power with SmartPower.

In case you do not have simulation vectors for your design, the following alternative flow is recommended:

1. Enter maximum delay, minimum delay, setup, and hold constraints in SmartTime's constraint editor or in SDC.
2. Set false paths on any paths that have a constraint, but do not need one (this will help layout to meet the constraints that are needed).
3. Perform Layout with **Timing-Driven**, **Run Place**, and **Run Route** options checked.
4. Resolve worst case setup and maximum delay violations.
5. Verify that your timing constraints are still met with SmartTime.
6. Open SmartPower and set clock frequencies and toggle rates for the different clocks. Clock frequencies can be imported from your timing constraints. Refer to [Initialize Frequencies](#) for more information.
7. Perform Layout with **Timing-Driven**, and **Power-Driven** options checked. Run Place and Route.
8. Verify that your timing constraints are still met with SmartTime.
9. Analyze your power with SmartPower

### Run Place

Select this option to run the placer during Layout. By default, it reflects the current Layout state. If you have not run Layout before, Run Place is selected by default. If your design has already been placed but not routed, this box is cleared by default. You can also select the following [incremental placement](#) options.

- **Incrementally**: Select to use previous placement data as the initial placement for the next place run.

- **Lock Existing Placement (fix):** Select to preserve previous placement data during the next incremental placement run.

Incremental options apply to the entire design. For more detailed control of the placer behavior (such as, to fix placement of a portion of the design), use the [MultiView Navigator](#) tools or set fixed attributes on the placed instances via PDC constraint files.

## Run Route

Select to run the router during Layout. By default, it reflects the current Layout state. If you have not run Layout before, Run Route is checked. Run Route is also checked if your previous Layout run completed with routing failures. If your design has been routed successfully, this check box is cleared.

- **Incrementally:** Select to fully route a design when some nets failed to route during a previous run. You can also use it when the incoming netlist has undergone an ECO. (Engineering Change Order). Incremental routing should only be used if a low number of nets fail to route (less than 50 open nets or shorted segments). A high number of failures usually indicates a less than optimal placement (if using manual placement through macros, for example) or a design that is highly connected and does not fit in the device. If a high number of nets fail, relax constraints, remove tight placement constraints, deactivate timing-driven mode, or select a bigger device and rerun Layout. Also, see the Advanced Layout options for your device.

There is no "Fix" option for the router. In incremental mode the router tries to preserve the existing routing; there is no guarantee that it will be preserved. Therefore the timing characteristics of the previously routed portion of the design may change, even if the placement was fixed for that portion of the design. The chance of this is quite small, and the router will print the list of nets that have fixed terminals (i.e. those nets whose every pin's macro has the placement FIX attribute).

## Use Multiple Passes

Select to run layout multiple times with different seeds. Multiple Pass Layout attempts to improve layout quality by selecting from a greater number of layout results. Click **Configure** to set your [Multiple Pass Configuration](#).

Click the [Advanced](#) button to set Timing-Driven options.

### See Also

[Running Layout](#)

## IGLOO, ProASIC3, SmartFusion and Fusion Advanced Layout Options

To set these advanced options during Layout, click **Advanced** in the Layout dialog box. The Advanced Layout options are only available in timing-driven Layout mode.

## High Effort Layout Mode

This option turns on netlist optimizations to obtain better performance. Layout runtime will increase when this option is selected. You can also combine this option with the Multi-Pass mode to achieve the best possible performance.

In the regular flow the compile step in Designer would modify the netlist to make use of efficient resources on the chip, such as global networks and special macros. When the **High Effort Layout** option is turned on, the placer could further change the mapping of the logic components, preserving the original functionality of the design. The changed netlist is then used in all post-layout Designer tools including back-annotation.

The names and types of the combinational core logic primitives may change. All other logic cells (such as registers, memory, I/Os or clocks) or combinational logic primitives that are assigned a physical constraint (locked at a location, assigned to a region, or part of a block component), referred in a timing constraint, or have a preserve property, will remain unchanged.

When the **Lock Existing Placement** option is also turned on, the placer runs in regular effort mode.

**Note:** Note: If you change the High Effort Setting you must re-run the placer and router to complete Layout.

## Sequential Optimization

This option turns on optimization of sequential cells in the High Effort Layout mode. This typically enables register retiming without disturbing timing latency. The names of registers may change unless they are assigned a physical constraint (locked at a location, assigned to a region, or part of a block component), referred in a timing constraint, or have a preserve property. Other restrictions may also apply.

## Router

### Repair Minimum Delay Violations

With this option selected, layout will perform an additional route that will attempt to repair paths that have minimum delay and hold time violations. This is done by increasing the length of routing paths and inserting routing buffers to add delay to paths. Since placement will remain unchanged and no additional tiles or modules will be inserted, the amount of delay inserted is limited. As a result, this function is best suited to repair paths with small (0 to 3 ns) hold and minimum delay violations. Paths with large violations will likely improve, but for a complete repair of these paths, manual placement or source code modification may be necessary. Every effort will be made to avoid creating max-delay timing violations on worst case paths.

To get the most out of repair minimum delay violations, it is recommended to:

1. Enter max-delay, min-delay, setup and hold constraints in SmartTime's [constraint editor](#) or in [SDC](#).
2. [Set false paths](#) on any paths that have a constraint, but do not need one (this will help layout to meet the constraints that are needed).
3. Perform [Layout](#) with **Timing Driven**, **Run Place**, **Run Route** and optionally **Run incrementally** enabled.
4. Resolve worst case setup and max-delay violations before running minimum delay violations repair.



5. After worst case max-delay timing is resolved, evaluate timing in SmartTime's [Timing Analyzer in minimum delay analysis](#) mode to check for hold time and minimum delay violations.
6. Run repair minimum delay violations with incremental route enabled.  
The repair minimum delay violations tool will attempt to fix all hold time and minimum delay violations by lengthening routing delay paths and inserting routing buffers. As delay is added to paths, worst case max-delay timing is verified to avoid creating new max-delay timing violations. Designer will report the worst minimum slack and the number of violating paths in the log window. In some cases, additional improvement can occur by running repair minimum delay violations multiple times with **Run Incrementally** enabled.
7. Perform both maximum and minimum delay timing analysis to check the timing. Manual placement or source code modification may be necessary to repair all minimum delay violations.
8. After making placement or source code changes, run incremental route and repair minimum delay violations, and then analyze timing again.

### Additional Factors

Runtime may vary greatly with the number of paths that need repair, the number of nets in those paths, and the resources available for the tool to insert delay. Over-constraining paths will increase runtime, but will not likely improve results .

The tool will only work on paths that have min delay and hold time constraints. However, other paths that share common nets to the constrained paths may be inadvertently affected.

It is recommended to run minimum delay violations repair with incremental route. This will ensure that paths which do not have minimum delay violations are preserved.

Repair will be performed on:

- Register to register paths where both registers are on the same global or non-global clock
- Register to register paths where the registers are on different clock networks and a minimum delay constraint exists
- Input to register, register to output, clock to out, input to output paths with minimum delay or hold constraint.

You may select programmable input delays to increase delay on input to register paths for devices that support the feature.

## Restore Defaults

Click Restore Defaults to run the factory default settings for Advanced options.

## ProASIC<sup>PLUS</sup> and ProASIC Layout Options

When [running layout](#), use the Layout Options dialog box to set your layout options.

## Timing-Driven

Select this option to run Timing-Driven Layout. The primary goal of timing-driven layout is to meet timing constraints, specified by you or generated automatically. Timing-driven Layout typically delivers better performance than Standard layout.

If you do not select Timing-driven layout, Designer runs Standard layout. Standard layout targets efficient usage of the chip resources. Chip performance is not optimized. Timing constraints are not considered by the Layout in standard mode, although a delay report based on delay constraints entered in Timer can still be generated for the design. This is helpful to determine if timing-driven Layout is required.

## Run Place

Select this option to run the placer during Layout. By default, it reflects the current Layout state. If you have not run Layout before, Run Place is selected by default. If your design has already been placed but not routed, this box is cleared by default. You can also select the following [incremental placement](#) options.

- **Incrementally:** Select to use previous placement data as the initial placement for the next place run.
- **Lock Existing Placement (fix):** Select to preserve previous placement data during the next incremental placement run.

Incremental options apply to the entire design. For more detailed control of the placer behavior (such as, to fix placement of a portion of the design), use the [MultiView Navigator](#) tools or set fixed attributes on the placed instances via GCF constraint files.

## Run Route

Select to run the router during Layout. By default, it reflects the current Layout state. If you have not run Layout before, Run Route is checked. Run Route is also checked if your previous Layout run completed with routing failures. If your design has been routed successfully, this check box is cleared.

- **Incrementally:** Select to fully route a design when some nets failed to route during a previous run. You can also use it when the incoming netlist has undergone an ECO. (Engineering Change Order). Incremental routing should only be used if a low number of nets fail to route (less than 50 open nets or shorted segments). A high number of failures usually indicates a less than optimal placement (if using manual placement through macros, for example) or a design that is highly connected and does not fit in the device. If a high number of nets fail, relax constraints, remove tight placement constraints, deactivate timing-driven mode, or select a bigger device and rerun Layout. Also, see the Advanced Layout options for your device.

There is no "Fix" option for the router. In incremental mode the router tries to preserve the existing routing; there is no guarantee that it will be preserved. Therefore the timing characteristics of the previously routed portion of the design may change, even if the placement was fixed for that portion of the design.

## Use Multiple Passes

Select to run layout multiple times with different seeds. Multiple Pass Layout attempts to improve layout quality by selecting from a greater number of layout results. Click **Configure** to set your [Multiple Pass Configuration](#).

Click the [Advanced](#) button to set Timing-Driven options.

### See Also

[Running Layout](#)

## ProASIC<sup>PLUS</sup> and ProASIC Advanced Layout Options

To set these advanced options during [Layout](#), click **Advanced** in the Layout dialog box.

### Layout Timing Weight

Setting this option to values within a recommended range of 1-4 changes the weight of the timing objective function, thus influencing the results of timing-driven place-and-route in favor of either routability or performance.

Value 4 (default) puts maximum emphasis on the performance; value 1 shifts priority to routability, but still evaluates timing goals during layout.

In general, the performance of a non-congested design increases with a higher timing weight setting. In highly congested designs the performance improves with lower timing weight settings because of better routability. Use intermediate values to balance the performance-routability tradeoff for your design.

For designs that are very congested, you may want to put even more emphasis to the routability than level 1 provides. In this case try running standard-mode placer, followed by the timing-driven router. If this is insufficient, run both place-and-route in standard mode.

**Note:** Note: If you change the Timing Weight you must re-run the placer to complete routing. Changing the Timing Weight has no effect if you do not re-run the placer.

### Restore Defaults

Click **Restore Defaults** to run the factory default settings for advanced options.

## Axcelerator Layout Options

When [running Layout](#), use the Layout Options dialog box to set your Layout options.

The I/O Bank Assigner runs automatically after you click OK in the Layout Options dialog box. The I/O Bank Assigner automatically assigns technologies to all I/O banks that have not been assigned a technology.

### Timing-Driven

Select this option to run Timing-Driven Layout. The primary goal of timing-Driven layout is to meet [timing constraints](#), with a secondary goal of producing high performance for the rest of the design. Timing-Driven Layout delivers performance that is superior to Standard Layout; Timing-Driven Layout is selected by default.

Layout is run in Standard mode when the Timing-Driven check box is cleared. The goal of Standard Layout is to optimize for routability.

### Power-Driven

Select this option to run Power-Driven Layout. The primary goal of power-driven layout is to reduce dynamic power while still maintaining timing constraints.

To get the most out of Power-Driven Layout, it is recommended to:

1. Enter maximum delay, minimum delay, setup, and hold constraints in SmartTime's constraint editor or in SDC.
2. Set false paths on any paths that have a constraint, but do not need one (this will help layout meet the constraints that are needed).
3. Perform Layout with **Timing-Driven** and **Power-Driven** options checked. Run Place and Route.
4. Verify that your timing constraints are still met with SmartTime.
5. Analyze your power with SmartPower.

## Run Place

Select this option to run the placer during Layout. If you have not run Layout before, Run Place is selected by default. If your design has already been placed but not routed, this check box is not selected. You can also select the following [incremental placement](#) options.

- **Incrementally:** Select to use previous placement data as the initial placement for the next placement run.
- **Lock Existing Placement (fix):** Select to use and lock previous placement data for the next incremental placement run.

### Effort Level

Use the Effort Level slider to increase the placement effort. The range is 1 to 5 with a default of 3. A higher level of effort generally improves the quality of results, but runs longer.

## Run Route

Select to run the router during Layout. If you have not run Layout before, Run Route is selected. Run Route is also selected if your previous Layout run completed with routing failures.

Incremental routing is available for Axcelerator devices. When activated, the option sets the previous routing information as the initial starting point. To use the incremental routing option in the script mode, see the Advanced Tcl Layout options for Axcelerator (in the Tcl Scripting section).

## Use Multiple Passes

Select to run Layout multiple times with different placement seeds. Multiple Pass Layout attempts to improve layout quality by selecting from a greater number of layout results. Click **Configure** to set your [Multiple Pass Configuration](#).

**Note:** Note: To run Multiple Passes, you must select both *Run Place* and *Run Route*.

## Axcelerator Advanced Layout Options

To set these advanced options during [Layout](#), click **Advanced** in the Layout dialog box.

### Router

#### Repair Minimum Delay Violations

With this option selected, layout will perform an additional route that will attempt to repair paths that have minimum delay and hold time violations. This is done by increasing the length of routing paths and inserting routing buffers to add delay to paths. Since placement will remain unchanged and no additional tiles or modules will be inserted, the amount of delay inserted is limited. As a result, this function is best suited to repair paths with small (0 to 3 ns) hold and minimum delay violations. Paths with large violations will likely improve, but for a complete repair of these paths, manual placement or source code modification may be necessary. Every effort will be made to avoid creating max-delay timing violations on worst case paths.

To get the most out of repair minimum delay violations, it is recommended to:

1. Enter max-delay, min-delay, setup and hold constraints in SmartTime's [constraint editor](#) or in [SDC](#).
2. [Set false paths](#) on any paths that have a constraint, but do not need one (this will help layout to meet the constraints that are needed).
3. Perform [Layout](#) with **Timing Driven**, **Run Place**, **Run Route** and/or **Run incrementally** enabled.
4. Resolve worst case setup and max-delay violations before running minimum delay violations repair.
5. After worst case max-delay timing is resolved, evaluate timing in SmartTime's [Timing Analyzer in minimum delay analysis](#) mode to check for hold time and minimum delay violations.
6. Run repair minimum delay violations with incremental route enabled.  
The repair minimum delay violations tool will attempt to fix all hold time and minimum delay violations by lengthening routing delay paths and inserting routing buffers. As delay is added to paths, worst case max-delay timing is verified to avoid creating new max-delay timing violations. Designer will report the worst minimum slack and the number of violating paths in the log window. In some cases, additional improvement can occur by running repair minimum delay violations multiple times with **Run Incrementally** enabled.
7. Perform both maximum and minimum delay timing analysis to check the timing. Manual placement or source code modification may be necessary to repair all minimum delay violations.
8. After making placement or source code changes, run incremental route and repair minimum delay violations, and then analyze timing again.

**Note:** Note: Runtime may vary greatly with the number of paths that need repair, the number of nets in those paths, and the resources available for the tool to insert delay. Over-constraining paths will increase runtime, but will not likely improve results.

The tool will only work on paths that have min delay and hold time constraints. However, other paths that share common nets to the constrained paths may be inadvertently affected.

Actel recommends that you run minimum delay violations repair with incremental route. This will ensure that paths which do not have minimum delay violations are preserved.

Repair will be performed on:

- Register to register paths where both registers are on the same global or non-global clock
- Register to register paths where the registers are on different clock networks and a minimum delay constraint exists
- Input to register, register to output, clock to out, input to output paths with minimum delay or hold constraint.

You may select programmable input delays to increase delay on input to register paths for devices that support the feature.

## Restore Default

Click Restore Defaults to run the factory default settings for Advanced options.

## eX, SX, SX-A Layout Options

When [running layout](#), use the Layout dialog box to set your layout options.

### Timing-Driven

Select to run Timing-Driven Layout. The primary goal of Timing-Driven layout is to meet timing constraints, while still producing high performance for the rest of the design. Timing-Driven Layout is more precise and typically results in higher performance. This option is available only when timing constraints have been defined.

When not checked, standard layout runs. Standard layout maximizes the average performance for all paths. Each part of a design is treated equally for performance optimization. Standard layout uses net weighting (or criticality) to influence the results. Delay constraints that have been set for a design during place-and-route are not considered, however a delay report based on delay constraints entered in Timer can still be generated for the design. This is helpful to determine if Timing-Driven Layout is required.

### Place Incrementally

Select to use previous placement data as the initial placement for the next place run.

- **Lock Existing Placement:** Select to preserve previous placement data during the next incremental placement run.

### Use Multiple Passes (eX and SX-A only)

Select to run layout multiple times with different seeds. Multiple Pass Layout attempts to improve layout quality by selecting from a greater number of layout results. Click **Configure** to set your [Multiple Pass Configuration](#).

Click the [Advanced](#) button to set Extended Run and Timing-Driven options.

## eX, SX, and SX-A Advanced Layout Options

To set these advanced options during [Layout](#), click the Advanced button in the Layout dialog box.

### Extended Run

Select this to run a greater number of iterations during optimization within a single layout pass. An extended run layout can take up to five times as long as a normal layout.

### Effort Level

This setting specifies the duration of the timing-driven phase of optimization during timing-driven Layout. Its value specifies the duration of this phase as a percentage of the default duration. This option is available only when timing constraints have been defined

The default value is 100 and the selectable range is 25 - 500. Reducing the effort level also reduces the run time of timing-driven place-and-route (TDPR). With an effort level of 25, TDPR is almost four times faster. With fewer iterations, however, performance may suffer. Routability may or may not be affected. With an effort level of 200, TDPR is almost two times slower. This variable does not have much effect on timing.

### Timing Weight

Setting this option to values within a recommended range of 10-150 changes the weight of the timing objective function, thus influencing the results of timing-driven place-and-route in favor of either routability or performance. This option is available only when timing constraints have been defined

The timing weight value specifies this weight as a percentage of the default weight (i.e. a value of 100 has no effect). If you use a value less than 100, more emphasis is placed on routability and less on performance. Such a setting would be appropriate for a design that fails to route with TDPR. In case more emphasis on performance is desired, set this variable to a value higher than 100. In this case, routing failure is more likely. A very high timing value weight could also distort the optimization process and degrade performance. A value greater than 150 is not recommended.

### Restore Defaults

Click **Restore Defaults** to run the factory default settings for advanced options.

## ACT, MX, and DX Layout Options

### Timing-Driven

Select this option to run Timing-Driven Layout. The primary goal of timing-driven layout is to meet timing constraints, with a secondary goal of producing high performance for the rest of the design. Timing-Driven Layout is more precise and typically results in higher performance. This option is available only when timing constraints have been defined.

When not checked, Designer runs standard layout. Standard layout maximizes the average performance for all paths. Each part of a design is treated equally for performance optimization. Standard layout uses net weighting (or criticality) to influence the results. Delay constraints that have been set for a design during place-and-route are not considered, however a delay report based on delay constraints entered in Timer can still be generated for the design. This is helpful to determine if Timing-Driven Layout is required.

## Place Incrementally

Select to use previous placement data as the initial placement for the next place run.

- **Lock Existing Placement:** Select to preserve previous placement data during the next incremental placement run.

Click [Advanced](#) to set Extended Run options.

## ACT, MX, and DX Advanced Layout Options

To set these advanced options during [Layout](#), click the Advanced button in the Layout dialog box.

### Extended Run

Select this to run a greater number of iterations during optimization. An extended run layout can take up to five times as long as a normal layout.

### Restore Default

Click **Restore Defaults** to run the factory default settings for advanced options.

#### See Also

[Running Layout](#)

[ACT, MX, and DX Layout options](#)

## Incremental Placement

In either standard or timing-driven mode, use incremental placement to preserve the timing of a design after a successful place-and-route, even if you change part of the netlist. Incremental placement has no effect the first time you run layout. During design iteration, incremental placement attempts to preserve the placement information for any unchanged macros in a modified netlist.

As a result, the timing relationships for unchanged macros approximate their initial values, decreasing the execution time to perform Layout. By forcing Designer to retain the placement information for a portion of the design, some flexibility for optimal design layout may be lost. Therefore, do not use incremental placement to place your design in pieces. You should only use it if you have successfully run Layout and you have minor changes to your design.

Incremental placement requires prior completion of place. Do not use incremental placement if the previous Layout failed to meet performance goals.



## Locking Existing Placement (Fix)

When the **Lock Existing Placement** option is selected in the Layout dialog box, all unchanged macros are treated as locked (fixed) placements during an incremental placement. This is the strongest level of control, but it may be too restrictive for the new placement to successfully complete. The default **ON** setting treats unchanged macro locations as placement hints, but alters their locations as needed to successfully complete placement. Refer to [ChipEditor](#) for details on locking macros.

## ProASIC and ProASIC<sup>PLUS</sup> Placement Constraint File (GCF)

For ProASIC and ProASIC<sup>PLUS</sup> designs, you can export a GCF constraint file to get all of the constraint information. From the **File** menu, choose **Export > Constraint Files**, type a file name and click **Save**, and then select **All GCF constraints** in the **Export GCF File** dialog box. Blocks with locked placement constraints generate locked placement constraints, while the others generate initial placement constraints. You can edit a GCF file to remove existing constraints or add new constraints. You must then import the modified GCF file as well as the netlist back into Designer. See [Importing Source Files](#) for more information about importing files.

## Running Multiple Pass Layout

Multiple Pass Layout attempts to improve layout quality by selecting from a greater number of Layout results. This is done by running individual place and route multiple times with varying placement seeds and measuring the best results with specified criteria.

**Note:** Note:

- Before running Multiple Pass Layout, you need to save your design.
- Multiple Pass Layout is supported in the following families: IGLOO, Fusion, ProASIC3, Axcelerator, ProASIC<sup>PLUS</sup>, ProASIC, SX-A, and eX.
- Multiple Pass Layout saves your design file with the pass that has the best layout results. If you want to preserve your existing design state, you should save your design file with a different name before proceeding. To do this, from the **File** menu, select **Save As**.
- Four types of reports (timing, maximum delay timing violations, minimum delay timing violations, and power) for each pass will be written out to the working directory to assist you in later analysis:
  - `<adbFileName>_timing_r<runNum>_s<seedIndex>.rpt`
  - `<adbFileName>_timing_violations_r<runNum>_s<seedIndex>.rpt`
  - `<adbFileName>_timing_violations_min_r<runNum>_s<seedIndex>.rpt`
  - `<adbFileName>_power_r<runNum>_s<seedIndex>.rpt`
  - `<adbFileName>_iteration_summary.rpt` provides additional details about the saved files

### To configure your multiple pass options:

1. When running Layout, select **Use Multiple Passes** in the Layout Options dialog box.

2. Click **Configure**. The Multi-Pass Configuration dialog box appears.
3. Set the options and click **OK**.

**Number of passes:** Set the number of passes (iterations) using the slider. 1 is the minimum and 25 is the maximum. The recommended number of passes is 5.

**Start at seed index:** Set the specific index into the array of random seeds which is to be the starting point for the passes.

**Measurement:** Select the measurement criteria you want to compare layout results against.

- **Slowest clock:** Select to use the slowest clock frequency in the design in a given pass as the performance reference for the layout pass.
- **Specific clock:** Select to use a specific clock frequency as the performance reference for all layout passes.
- **Timing violations:** Select to use the pass that best meets the slack or timing-violations constraints. Note: You must enter your own timing constraints through the SmartTime or SDC.
- **Maximum delay:** Select to examine timing violations (slacks) obtained from maximum delay analysis.
- **Minimum delay:** Select to examine timing violations (slacks) obtained from minimum delay analysis.
- **Select by:** Worst Slack or Total Negative Slack to specify the slack criteria.
  - When Worst Slack is selected, the most amount of negative slack (or least amount of positive slack if all constraints are met) for each pass is identified, and then the largest value out of all passes determines the best pass.
  - When Total Negative Slack is selected, the sum of negative slacks from the first 100 paths for each pass is identified, and then the largest value out of all the passes determines the best pass. If no negative slacks exist for a pass, then the worst slack is used to evaluate that pass.
- **Stop on first path without violations:** Select to stop performing remaining passes if all timing constraints have been met (when there are no negative slacks reported in the timing violations report).
- **Total power:** Select to determine the best pass to be the one that has the lowest total power (static + dynamic) out of all layout passes.

**Save design file for each pass:** Select to save the design \*.adb file for each pass. By default, only the best result is saved to your design. With this option, every pass stores its design file as `<adbFileName>_r<runNum>_s<seedIndex>.adb`. The "best"-pass design will also be written back to the original \*.adb file. Saving all results does take more disk space, but allows you to analyze the result of each pass later in more detail. `<adbFileName>_iteration_summary.rpt` provides additional details about the saved files.

## Iteration Summary Report

The file `<adbFileName>_iteration_summary.rpt` records a summary of how the multiple pass run was invoked either through the GUI or `extended_run_shell` Tcl script, with arguments for repeating each run. Each new run appears with its own header in the Iteration Summary Report with fields **RUN\_NUMBER** and **INVOKED AS**, followed by a

table containing **Seed Index**, corresponding **Seed** value, Comparison data, **Report Analyzed**, and **Saved Design** information.

### Example

The first header displays information about the first run invoked from the command line ([extended\\_run\\_shell](#)). The second run was invoked from the Designer GUI ([extended\\_run\\_gui](#)).

```

Iteration_Summary_Report Text.txt - Notepad
File Edit Format View Help
# RUN NUMBER: 1 DATE: 17:25:58 26-Jul-2007
# INVOKED AS: acctclsh.exe extended_run_shell.tcl -adb my.adb -n 2
#
# Seed Index Seed Slowest Clock Frequency Report Analyzed Saved Design
# -----
# 1 1 N/A Layout failed my_timing_r1_s1.rpt
# 2 86662958 PCI_SCLK 89.582 my_timing_r1_s2.rpt
#
# RUN NUMBER: 2 DATE: 17:33:24 26-Jul-2007
# INVOKED AS: extended_run_gui.tcl -n 2 -save_all -starting_seed_index 3 -c PCI_SCLK
#
# Seed Index Seed Specific Clock Frequency Report Analyzed Saved Design
# -----
# N/A 86662958 PCI_SCLK 89.582 my_timing_r2_initial.rpt ./my_r2_initial.adb
# 3 8988747 N/A Layout failed my_timing_r2_s3.rpt ./my_r2_s3.adb
# 4 51071856 PCI_SCLK 85.339 my_timing_r2_s4.rpt ./my_r2_s4.adb
#
# RUN NUMBER: 3 DATE: 17:41:44 26-Jul-2007
# INVOKED AS: acctclsh.exe extended_run_shell.tcl -adb my.adb -n 2 -save_all -compare_criteria violations
#
# Seed Index Seed Maximum Delay Worst Slack Report Analyzed Saved Design
# -----
# N/A 86662958 N/A -3.462 my_timing_violations_max_r3_initial.rpt ./my_r3_initial.adb
# 5 78381505 N/A -3.676 my_timing_violations_max_r3_s5.rpt ./my_r3_s5.adb
# 6 82287664 N/A Layout failed my_timing_violations_max_r3_s6.rpt ./my_r3_s6.adb
#
# RUN NUMBER: 4 DATE: 17:51:34 26-Jul-2007
# INVOKED AS: acctclsh.exe extended_run_shell.tcl -adb my.adb -n 2 -save_all -compare_criteria violations -slack_criteria tns
#
# Seed Index Seed Maximum Delay Total Neg Slack Report Analyzed Saved Design
# -----
# N/A 86662958 N/A -204.875 my_timing_violations_max_r4_initial.rpt ./my_r4_initial.adb
# 7 23702026 N/A -205.795 my_timing_violations_max_r4_s7.rpt ./my_r4_s7.adb
# 8 51370950 N/A Layout failed my_timing_violations_max_r4_s8.rpt ./my_r4_s8.adb
#
# RUN NUMBER: 5 DATE: 17:59:15 26-Jul-2007
# INVOKED AS: acctclsh.exe extended_run_shell.tcl -adb my.adb -n 2 -save_all -compare_criteria violations -analysis min
#
# Seed Index Seed Minimum Delay Worst Slack Report Analyzed Saved Design
# -----
# N/A 86662958 N/A 0.357 my_timing_violations_min_r5_initial.rpt ./my_r5_initial.adb
# 9 93189207 N/A 0.357 my_timing_violations_min_r5_s9.rpt ./my_r5_s9.adb
# 10 17538078 N/A 0.346 my_timing_violations_min_r5_s10.rpt ./my_r5_s10.adb
Ln 15, Col 96
    
```

Figure 70 · Iteration Summary Report

### See Also

- [Running Layout](#)
- [extended\\_run\\_shell](#)
- [extended\\_run\\_gui](#)

## Analyzing timing in your design

You can perform timing analysis using the SmartTime or Timer tool.

The following table lists the timing tool you can use for your device family.

Family	SmartTime	Timer
--------	-----------	-------

Family	SmartTime	Timer
Fusion	X	
IGLOO		
IGLOOe	X	
ProASIC3	X	
ProASIC3E	X	
ProASICPLUS	X	
Axcelerator	X	
ProASIC	X	
eX	X	
SX-A	X	
SX		X
MX		X
3200DX		X
ACT3		X
ACT2 /1200XL		X
ACT1		X

For details on SmartTime, refer to the [SmartTime online help](#).

For details on Timer, refer to the [Timer online help](#).

## Analyzing power consumption in your design

Use the SmartPower tool to analyze your designs power consumption. Use the SmartPower tool to:

- [Define clock domains](#)
- [Specify individual pin frequencies](#)

- [View detailed hierarchical analysis of your design](#)
- [View global power consumption at the design level](#)

If you wish, you may also [view the equations](#) that SmartPower uses to calculate your power consumption.

## Viewing your netlist

The NetlistViewer tool displays the contents of the design as a schematic, making it easier for you to debug your design. With NetlistViewer, you can view nets, ports, and instances in the schematic view. You can also isolate specific sections of your netlist to simplify your analysis and cross probe with other tools.

There are two versions of the NetlistViewer tool: NetlistViewer in MultiView Navigator (MVN) and NetlistViewer (non-MVN). Which version you use depends on which family you are designing for.

- [NetlistViewer in MultiView Navigator](#) supports IGLOO, Fusion, ProASIC3, ProASIC <sup>PLUS</sup>, ProASIC, Axcelerator, eX, and SX-A families.
- [NetlistViewer \(non-MVN\)](#) supports MX, DX, ACT3, ACT2, and ACT1 families.

Used with PinEditor in MultiView Navigator, ChipPlanner, or SmartTime, NetlistViewer in MultiView Navigator assists you in meeting area and timing goals by helping you with critical path identification. NetlistViewer (non-MVN) can also be used alone or with PinEditor Standalone, ChipEditor, or Timer.

When you open your design (.adb) file, Designer will automatically present you with the appropriate tools in the Design Flow window. You must compile your design before you can open it in NetlistViewer.

### See Also

[Overview- MultiView Navigator](#)

[About NetlistViewer in MultiView Navigator](#)

[About NetlistViewer \(non-MVN\)](#)

## Back-Annotation

The back-annotation functions are used to extract timing delays from your post layout data. These extracted delays are put into a file to be used by your CAE package's timing simulator. If you wish to perform pre-layout back-annotation, select **Export** and **Timing Files** from the **File** menu.

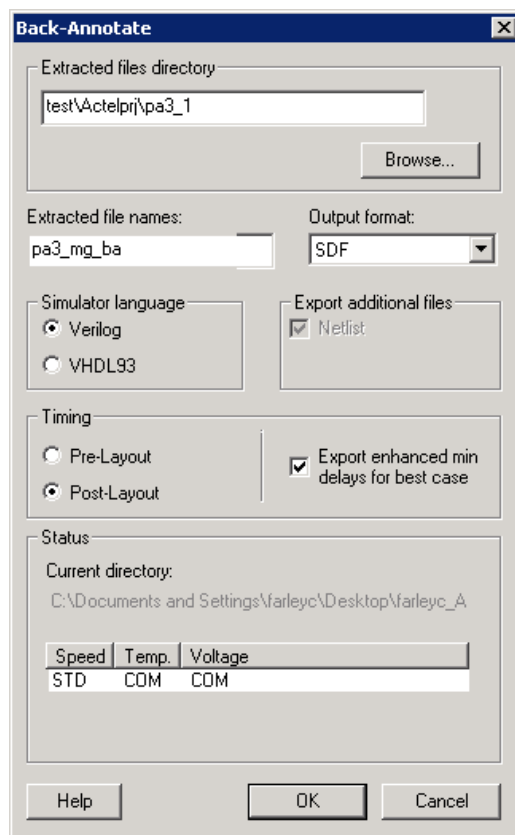

Figure 71 · Back-Annotate Dialog Box

The Back-Annotation command creates the files necessary for back-annotation to the CAE file output type that you choose. Refer to Actel interface guides or the documentation included with your simulation tool for information about selecting the correct CAE output format and using the back-annotation files.

#### **To back-annotate your design:**

1. From the **Tools** menu, choose **Back-Annotate**.
2. Make your selections in the Back-Annotate dialog box and click **OK**.

**Extracted Files Directory:** The file directory is your default working directory. If you wish to save the file elsewhere, click **Browse** and specify a different directory.

**Extracted File Names:** This name is used as the base-name of all files written out for back-annotation. Do not use directory names or file extensions in this field. The file extensions will be assigned based on your selection of which file formats to export. The default value of this field is <design>\_ba. The Extracted File Names field is disabled when you open Designer from the Libero IDE. If you wish to change your extracted file name, you must change the name of your file (**Save As**) and save it outside of the Libero IDE folder structure.

**Output Formats:** Select the file format of the timing file, SDF or STF.

(STF is only supported for DX, MX, and SX).

**Simulator Language:** Select either Verilog or VHDL93.

**Export Additional Files:** Check **Netlist** or **Pin** to export these files at the same time. For Fusion, IGLOO, ProASIC3, and Axcelerator families, you must export and use the "flattened" netlist (AFL-style) with the back-annotated timing file (SDF) in timing simulation.

**Timing - Pre-Layout or Post-Layout** sets whether you want to export your pre- or post-layout timing files for back-annotation. You can use pre-layout to backannotate your netlist before place-and-route, but it is less precise than post-layout timing. Post-layout is more precise because it contains your actual design implementation.

**Export enhanced min delays for best case** - This option changes the best-case number in the SDF file. By default, best case numbers are derived from typical operating conditions. If you enable this option, best case numbers also reflect minimum delay, including variations in process and die.

**Note:** Note: For IGLOO, ProASIC3, SmartFusion, Fusion, Axcelerator, and RTAX-S families you cannot select SDF format using File > Export Files > Timing.

You must export the netlist from the back-annotate command for IGLOO, ProASIC3, SmartFusion, Fusion, and Axcelerator. This selection is hard-coded to be ON. For all other families, the export-netlist and back-annotate actions generate equivalent netlist files, so the back-annotate command does not enforce the writing out of the netlist during back-annotate.

## Report types

You can generate the following types of reports in Designer:

Report Type	Report	Supported Families	Report Contents
Status	<a href="#">Status</a>	All	Provides information about Designer, Device Data, and variable settings for the design.
Timing	<a href="#">Timer (using SmartTime)</a>	IGLOO, ProASIC3, SmartFusion, Fusion, Axcelerator, RTAX-S, eX, and SX-A	Provides a text report with the timing information organized by clock domain as in the GUI.
	<a href="#">Timer (using Timer)</a>	SX, MX, 3200DX, ACT3, ACT2, and ACT1	Displays summarized timing delays for paths.
	<a href="#">Bottleneck</a>	IGLOO, ProASIC3, SmartFusion, Fusion, Axcelerator, RTAX-S, eX,	Creates a report containing information about the bottlenecks in the design.

Report Type	Report	Supported Families	Report Contents
		and SX-A	
	<a href="#">Constraints Coverage</a>	IGLOO, ProASIC3, SmartFusion, Fusion, Axcelerator, RTAX-S, eX, and SX-A	Creates a report containing information about the constraints in the design.
	<a href="#">Datasheet</a>	IGLOO, ProASIC3, SmartFusion, Fusion, Axcelerator, RTAX-S, eX, and SX-A	Creates a report containing information about the external characteristics of the design.
	<a href="#">Timing Violations (using SmartTime)</a>	IGLOO, ProASIC3, SmartFusion, Fusion, Axcelerator, RTAX-S, eX, and SX-A	Provides a flat slack report centered around constraint violations.
	<a href="#">Combinational Loops</a>	IGLOO, ProASIC3, SmartFusion, Fusion, Axcelerator, RTAX-S, eX, and SX-A	This report displays all loops found during initialization and reports pins associated with the loop(s), and the location where the loop is broken.
Resources	<a href="#">Pin</a>	All	Creates a text list of the I/O signal locations on a device. You can generate a pin report sorted by I/O signal names or by package number.
	<a href="#">Flip Flop</a>	All	Creates a report that lists the number and type of flip-flops (sequential or CC, which are flip-flops made of 2 combinatorial macros) used in a design. The flip-flop report can be of two types: Summary or Extended.  Both types of reports include the Flip-Flop type, sequential (Seq)



Report Type	Report	Supported Families	Report Contents
			or combinatorial (CC), the Library name, and the Total number of Seq and CC Flip-Flops in the design. The Summary Report also includes the Number of instances of each unique type. The Extended Report provides the Macro name. All Reports are output to an editable window for viewing, modifying, saving, and printing.
IOBank	<a href="#">IO Bank</a>	IGLOO, ProASIC3, SmartFusion, Fusion, and Axcelerator	Provides information on the I/O functionality, I/O technologies, I/O banks and I/O voltages.
Power	<a href="#">Power</a>	IGLOO, ProASIC3, SmartFusion, Fusion, ProASIC <sup>PLUS</sup> , ProASIC, and Axcelerator	Enables you to quickly determine if any power consumption problems exist in your design. The power report lists the following information: - Global device information and SmartPower Preferences selection information - Design level static power summary - Dynamic power summary - Hierarchical detailed power report (including gates, blocks, and nets), with a block by block, gate by gate, and net by net power summary SmartPower results.
	<a href="#">Power Cycle Accurate</a>	IGLOO, ProASIC3, SmartFusion, Fusion, ProASIC <sup>PLUS</sup> , ProASIC, Axcelerator, and RTAX-S	Creates a report containing a power waveform with one power value per clock period of half-period instead of an average power for the whole simulation.
	<a href="#">Power Activity and Hazards</a>	IGLOO, ProASIC3, SmartFusion, Fusion, ProASIC <sup>PLUS</sup> , ProASIC, Axcelerator, and RTAX-S	Creates a report containing information about transitions and hazards for each clock cycle of the VCD file.
	<a href="#">Power Scenario</a>	IGLOO, ProASIC3, SmartFusion, Fusion, ProASIC <sup>PLUS</sup> , ProASIC, Axcelerator, and RTAX-S	Creates a report containing information about the average power consumption and battery life for a sequence of previously defined <a href="#">operating modes</a> .
Global	<a href="#">CCC Configuration</a>	IGLOO, ProASIC3, SmartFusion and Fusion	The <a href="#">Fusion Dynamic CCC</a> (DYNCCC) and <a href="#">ProASIC3E Dynamic CCC</a> prints out all the values of the configuration pins

Report Type	Report	Supported Families	Report Contents
			in a report. You can use these to specify the bitstream that can be shifted in via the shift register.
	<a href="#">GlobalNet</a>	ProASIC <sup>PLUS</sup> , ProASIC	Creates a report containing information about the net(s) that are assigned or routed using Global or LocalClock resources.
	<a href="#">Global Usage</a>	ProASIC <sup>PLUS</sup> , and ProASIC	Provides information about the net(s) that are assigned or routed using Global or LocalClock resources.
Block	<a href="#">Block Report</a>	IGLOO, ProASIC3, SmartFusion, Fusion, Axcelerator, and RTAX-S	Creates a report specifically for Blocks and their implementation. Includes Compile, Datasheet, Global, and Interface information.

## Status Reports

The status report enables you to create a report containing device and design information, such as die, package, percentage of the logic and I/O modules used, etc.

### **To generate a status report:**

From the **Tools** menu, choose **Reports > Status**. The status report opens in a separate window. You can save or print the report.

## Generating a Timing Report

The timing report enables you to quickly determine if any timing problems exist in your design. The timing report lists the following information about your design:

- Maximum delay from input I/O to output I/O
- Maximum delay from input I/O to internal registers
- Maximum delay from internal registers to output I/O
- Maximum delays for each clock network
- Maximum delays for interactions between clock networks

### **To generate a timing report:**

1. From the Designer **Tools** menu, choose **Reports > Timing > Timer**. The [Timing Report Options dialog box](#) appears.

2. Select the options you want to include in the report, and then click **OK**.

The timing report appears in a separate window.

You can also generate the timing report from within SmartTime. From the **Tools** menu, choose **Reports > Report Paths**.

#### See Also

[Understanding timing report](#)

[Timing Report Options dialog box](#)

## Generating a Timing Violation Report

The timing violations report provides a flat slack report centered around constraint violations.

#### To generate a timing violation report

1. From the Designer **Tools** menu, choose **Reports > Timing > Timing Violations**. The [Timing Violation Report Options dialog box](#) appears.
2. Select the options you want to include in the report, and then click **OK**. The timing violations report appears in a separate window.

You can also generate the timing violations report from within SmartTime. From the **Tools** menu, choose **Reports > Report Violations**.

#### See Also

[Understanding timing violation report](#)

[Timing Violations Report Options dialog box](#)

## Generating a Bottleneck Report

The bottleneck report provides a list of the bottlenecks in the design.

To generate a bottleneck report, from the Designer **Tools** menu, select **Reports > Timing > Bottleneck**. The report appears in a separate window.

You can also generate the bottleneck report from within SmartTime. From the **Tools** menu, choose **Reports > Report Bottlenecks**.

#### See Also

[Understanding the bottleneck report](#)

[Timing Bottleneck Report Options dialog box](#)

## Generating a Datasheet Report

The datasheet reports information about the external characteristics of the design.

To generate a datasheet report, from the Designer **Tools** menu, select **Reports > Timing > Datasheet**. The report appears in a separate window.

You can also generate the datasheet report from within SmartTime. From the **Tools** menu, choose **Reports > Datasheet**.

### See Also

[Understanding the datasheet report](#)

[Timing Datasheet Report Options dialog box](#)

## Generating a Constraints Coverage Report

The constraints coverage report contains information about the constraints in the design.

To generate a constraints coverage report, from the Designer **Tools** menu, select **Reports > Timing > Constraints Coverage**. The report appears in a separate window.

You can also generate the constraints coverage report from within SmartTime. From the **Tools** menu, choose **Reports > Constraints Coverage**.

### See Also

[Understanding constraints coverage reports](#)

## Generating a Combinational Loop Report

The combinational loop report displays all loops found during initialization and reports pins associated with the loop(s), and the location where the loop is broken.

To generate a combinational loop report, from the Designer **Tools** menu, select **Reports > Timing > Combinational Loop**. The report appears in a separate window.

You can also generate the combinational loop report from within SmartTime. From the **Tools** menu, choose **Reports > Combinational Loop**.

### See Also

[Understanding Combinational Loop Reports](#)

## Pin reports

The pin report allows you to create a text list of the I/O signal locations on a device. You can generate a pin report sorted by I/O signal names or by package number.

### To generate a pin report:

1. From the Tools menu, choose **Reports > Resources > Pin**. This displays the Pin Report dialog box.
2. Select **Number** or **Name** from the List By pull-down menu, then click **OK**. This displays the pin report.

## Flip-flop reports

The flip-flop report enables you to create a report that lists the number and type of flip-flops used in a design.

**In ProASIC3:** CC macros in the report are multi-tile flip-flops, which are flip-flops, made of 2 or 4 tiles

**All other families:** CC macros are flip-flops made of 2 combinatorial macros.

You can generate two types of reports - Summary or Extended:

A Summary report displays whether the flip-flop is a sequential, or multi-tile flip-flop, the macro implementation of the flip-flop, and the number of times the implementation of the flip-flop is used in the design.

An Extended report lists the names of the macros in the design individually.

### **To generate a flip-flop report:**

1. From the **Tools** menu, choose Reports > Resources > FlipFlop. This displays the Flip-Flop Report Options dialog box.
2. Select Summary or Extended from the Type pull-down menu, then click **OK**. This displays the report in a separate window.

## I/O Bank Reports

The I/O Bank report provides information about the I/O functionality, I/O technologies, I/O banks and I/O voltages.

### **To generate the I/O bank report:**

From the **Tools** menu, choose **Report > IOBank**. The IOBank report opens in a separate window. You can save or print the report.

The following section shows an excerpt from the I/O Bank report:

I/O Function:

Type	w/o register	w/ register	w/ DDR register
Input I/O	20	0	0
Output I/O	17	0	0
Bidirectional I/O	1	0	0
Differential Input I/O Pairs	0	0	0
Differential Output I/O Pairs	0	0	0

I/O Technology:

I/O Standard(s)	Voltages		I/Os		
	Vcci	Vref	Input	Output	Bidirectional
LVTTL	3.30v	N/A	20	17	1

I/O Bank Resource Usage:

	Voltages		Single I/Os		Diff I/O Pairs		Vref I/Os		
	Vcci	Vref	Used	Total	Used	Total	Used	Total	Vref Pins
Bank0	3.30v	N/A	0	25	0	12	N/A	N/A	N/A
Bank1	3.30v	N/A	0	15	0	7	N/A	N/A	N/A
Bank2	3.30v	N/A	0	17	0	6	N/A	N/A	N/A
Bank3	3.30v	N/A	0	16	0	7	N/A	N/A	N/A
Bank4	3.30v	N/A	0	15	0	7	N/A	N/A	N/A
Bank5	3.30v	N/A	0	22	0	10	N/A	N/A	N/A
Bank6	3.30v	N/A	0	19	0	9	N/A	N/A	N/A
Bank7	3.30v	N/A	0	18	0	7	N/A	N/A	N/A

I/O Voltage Usage:

Vcci	Voltages		I/Os	
	Vref	Used	Total	
3.30v	N/A	38	147	

## I/O Functionality

This section of the report indicates the total number of regular input, output, and bidirectional signals. This also shows the differential input and output in the design. The I/O categories are: regular I/Os, registered I/Os or DDR I/Os in the current design.

## I/O Technologies

This section of the report specifies the VCCI and VREF voltage requirements for each I/O standard and the number of user I/Os per I/O standards used in the current design.

**Note:** Note: For voltage referenced I/O standards, input and bidirectional I/Os require both a VCCI and a VREF power supply whereas output I/Os only require a VCCI power supply. This is why these two categories are shown separately in this section.

## I/O Banks

This section of the report specifies the following [I/O bank](#) characteristics:

- VCCI and VREF voltages assigned for each bank.

- Total number of single-ended I/Os available and used for each bank.
- Total number of differential I/O pairs available and used for each bank.
- Total number of VREF pins assigned for each bank. This information is only relevant if a bank has been assigned a VREF voltage.
- Total number of voltage referenced I/Os available and used for each bank. Voltage referenced I/Os are available only if VREF pins have been assigned.

## I/O Voltages

This section of the report indicates the current design voltage requirements.

For each VCCI and VCCI/VREF user I/O demand in the current design, this table reports the total number of bonded I/Os available on the device that satisfy this demand.

**Note:** Note: For an I/O bank assignment (VCCI and VREF assignment) to be valid for the current design, the I/O voltage table must show no violation. Violations are indicated with an asterisk ("\*") when the number of user I/Os that need a given VCCI or VCCI/VREF assignment is less than the total number of bonded I/Os that can satisfy this demand.

## Power Reports

The power report enables you to quickly determine if any power consumption problems exist in your design.

### **To generate a power report:**

1. From the Designer **Tools** menu, choose **Reports > Power > Power**. The Power Report dialog box appears.
2. Select the options you want to include in the report, and then click **OK**. The power report appears in a separate window.

You can also generate the power report from within SmartPower. From the **Tools** menu, choose **Reports > Power Report**, or click the **Report** button to open the **Report** dialog box. By default, the report includes global design information and a power summary. Specify which results you want to display by selecting the categories and their options.

The power report dialog box is organized in the following panels: [General](#), [Operating Conditions](#), [Options](#), [Breakdown by Instance](#), [Frequency Summary](#), and [Probability Summary](#).

## General

The general panel enables you to select what to include in the report, the report format, and the mode that you want to generate the report for.

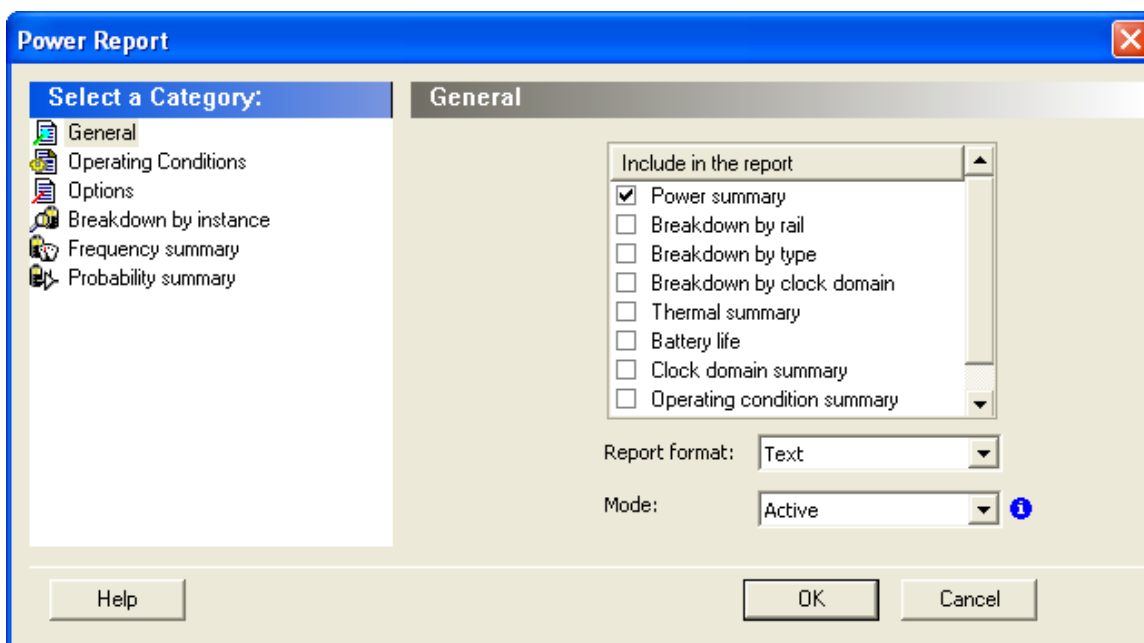

Figure 72 · SmartPower Power Report Dialog Box - General Panel

### Include in the Report

Select the option(s) that you want to include in the Power Report:

**Power summary** – This section reports the static, dynamic and total power consumption of the design.

**Breakdown by rail** – This section shows the power consumption of each rail.

**Breakdown by type** – This section enables reporting on the power consumption according to: gates, nets, clocks, core static, IOs and memories.

**Breakdown by clock domain** – This section enables reporting on the power consumption of each clock domain.

**Thermal summary** – This section includes a thermal report. The ambient temperature can be defined by the operating conditions or defined by the ambient temperature.

When the first option is selected, the following characteristics are reported:

- Operating conditions
- Temperature range
- Junction temperature

When the second option is selected, the following characteristics are reported:

- Ambient temperature
- Cooling style
- Package
- Thermal resistance Theta-JA



- Junction temperature
- Temperature range
- Junction temperature range limits specification

**Battery Life** – This section reports the battery life.

**Clock Domain Summary** – This section reports the clock and data frequencies for each clock domain.

**Operating Condition Summary** – This section reports the operating conditions.

**Annotation Coverage** – This section reports the number and percentage of pins annotated by each source (VCD, manual annotation, SmartTime constraint, vectorless estimation, and fixed values) for all clocks, register outputs, combinational outputs, set/reset nets, primary inputs, enable pins, and other pins

### Report Format

Select **Text** or **CSV** (Comma Separated Value) as the desired export format.

### Mode

Select a mode to generate the report for.

## Operating Conditions

The Operating Conditions panel enables you to select the operating conditions for the current report.

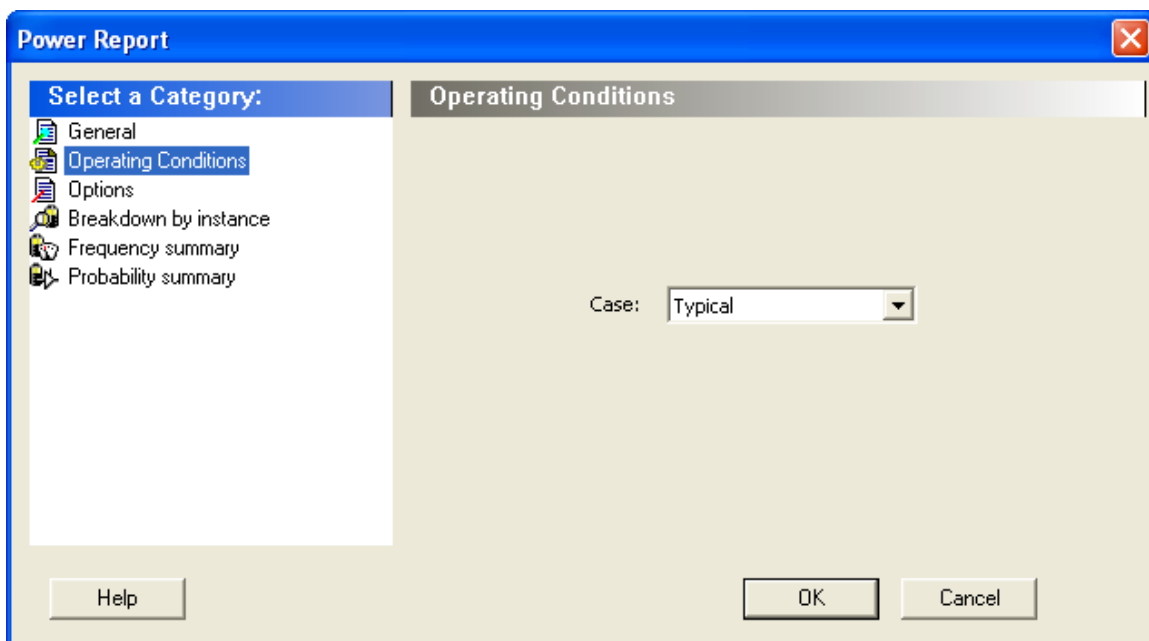

Figure 73 · SmartPower Power Report Dialog Box - Operating Conditions Panel

## Options

The Options panel enables you to select power and frequency units and to use toggle rates.

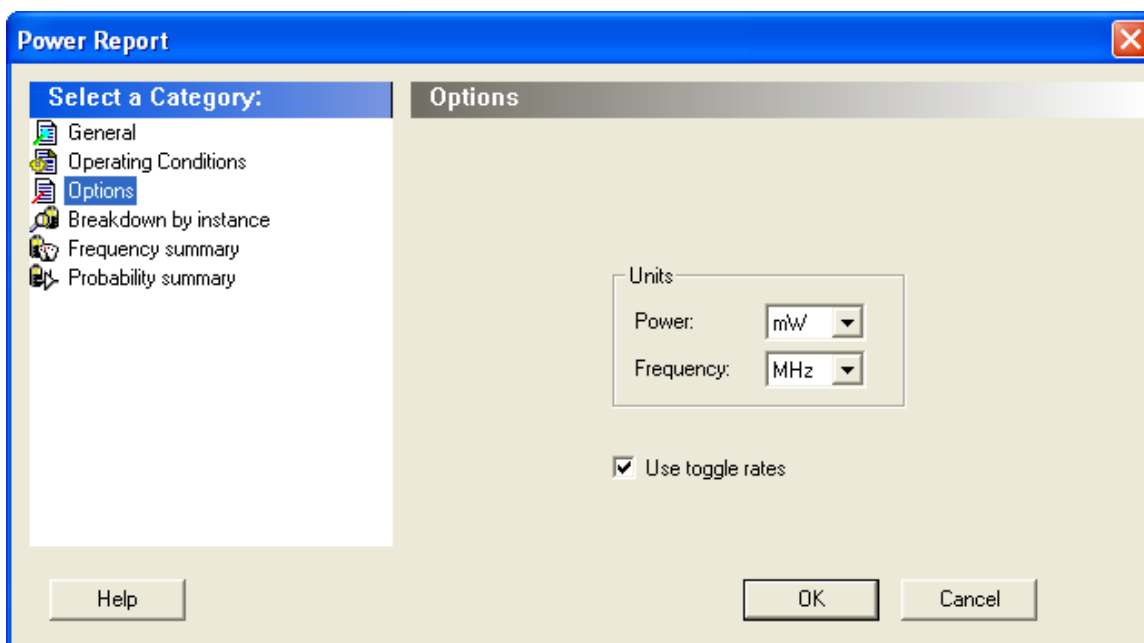

Figure 74 · SmartPower Power Report Dialog Box - Options Panel

### Units

**Frequency:** Sets unit preferences for frequency - Hz, KHz, MHz.

**Power Units:** Sets unit preferences for power - W, mW, or uW.

### Use Toggle Rates

When toggle rates are active (**Use Toggle Rates** box is checked), the data frequency of all the clock domains is defined as a function of the clock frequency. This updates the data frequency automatically when you update the clock frequency. Toggle rates enable you to specify the data frequency as a percentage of clock frequency, but you can no longer specify the data frequency as a number, only as a percentage of the clock frequency. To set the data frequency again, clear the **Use Toggle Rates** option.

### Breakdown by Instance

From this panel you can include the breakdown by instance in the report and set specific options.

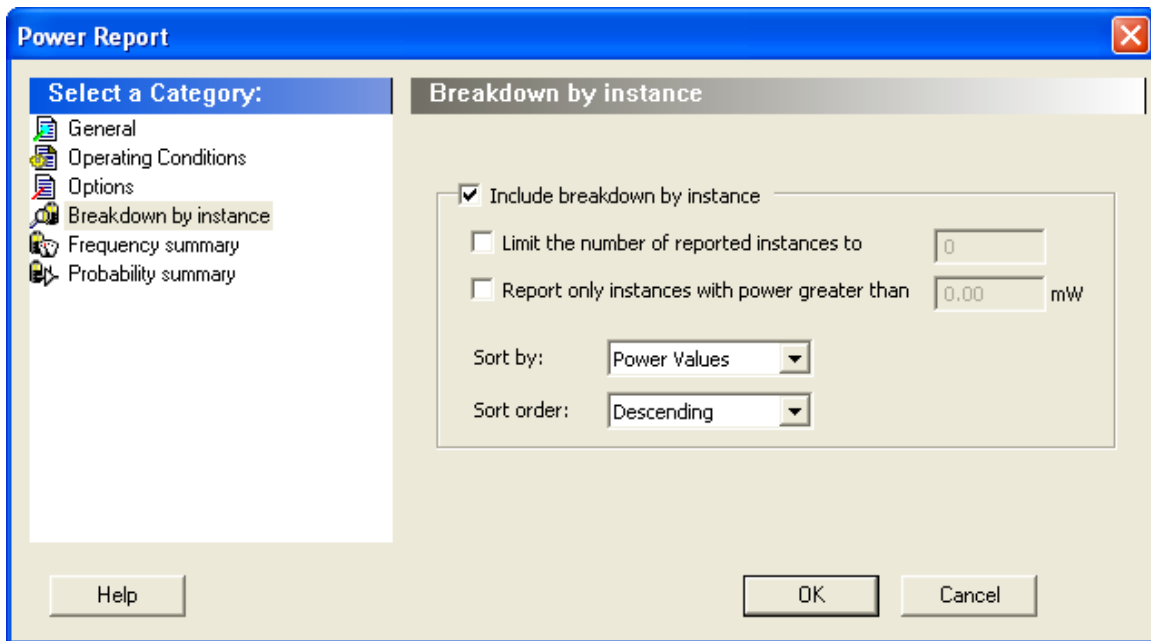

Figure 75 · SmartPower Power Report Dialog Box - Breakdown By Instance Panel

**Include breakdown by instance** – This section shows the power consumption of each element that has been instantiated in the design: gates, nets, memories, and IOs.

The breakdown by instance can be filtered by:

- **Limit the number of reported instances to:** will limit the number of instances reported to the specified number.
- **Report only instances with power greater than:** any instance with power consumption below the selected value will not be reported.

This section can be sorted by selecting the preferred method:

- **Sort by:** Name (alphabetical) or Power Values
- **Sort Order:** Ascending or Descending

**Note:** Note: The filter reduces the number of lines in the report, one per instance.

## Frequency Summary

From this panel you can include the frequency summary in the report and set specific options.

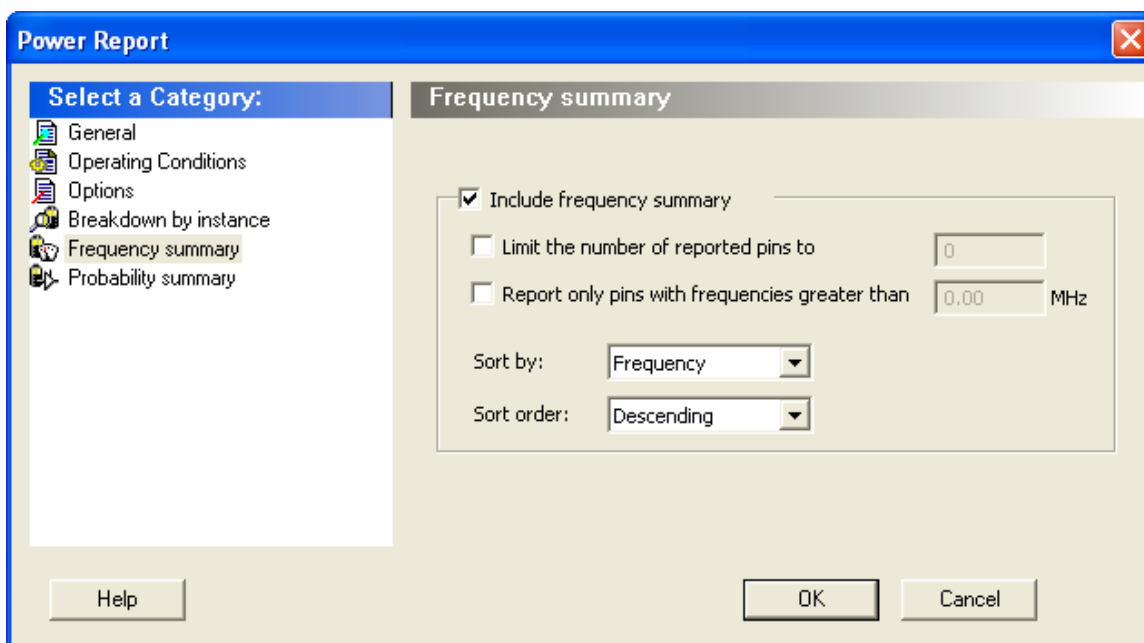

Figure 76 · SmartPower Power Report Dialog Box - Frequency Summary Panel

**Include frequency summary** – This section shows the frequency summary and reports the pin, net, domain, frequency, and frequency source for each pin.

The frequency summary can be filtered by:

- **Limit the number of reported pins to:** will limit the number of pins reported to the specified number.
- **Report only pins with frequencies greater than:** any pin with a frequency below the selected value will not be reported.

This section can be sorted by selecting the preferred method:

- **Sort by:** Pin Name, Net Name, Domain, Frequency, or Source
- **Sort Order:** Ascending or Descending

## Probability Summary

From this panel you can include the probability summary in the report and set specific options.

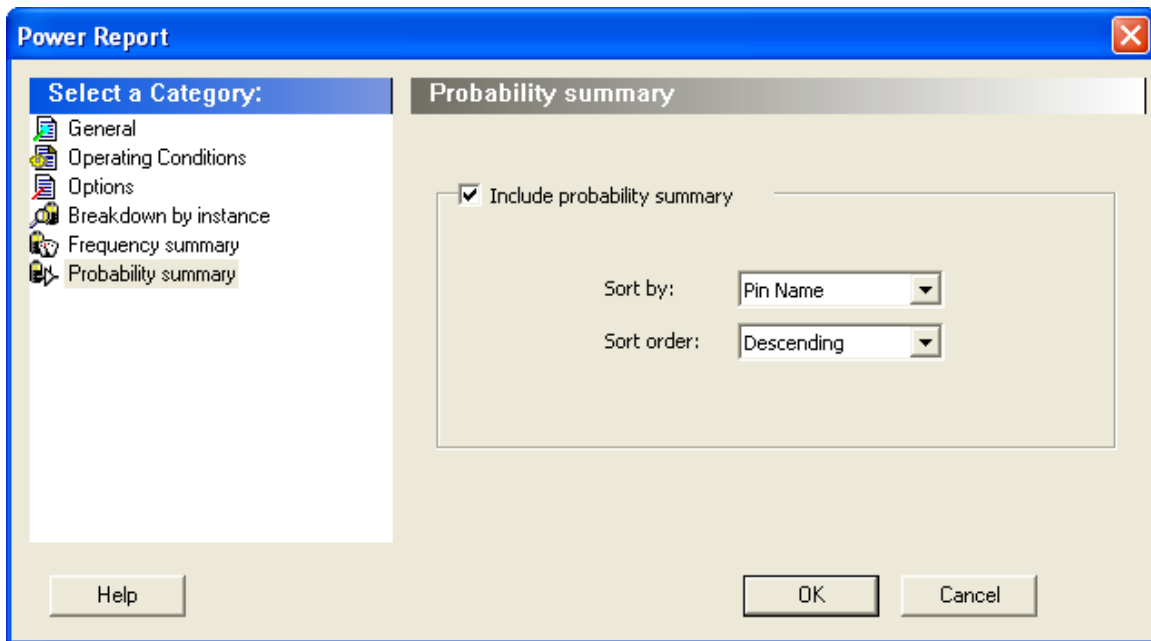

Figure 77 · SmartPower Power Report Dialog Box - Probability Summary Panel

**Include probability summary** – This section shows the probability summary and reports the driver, net, rate, source, and type for each pin.

This section can be sorted by selecting the preferred method:

- **Sort by:** Pin Name, Net Name, Rate, Source, or Type
- **Sort Order:** Ascending or Descending

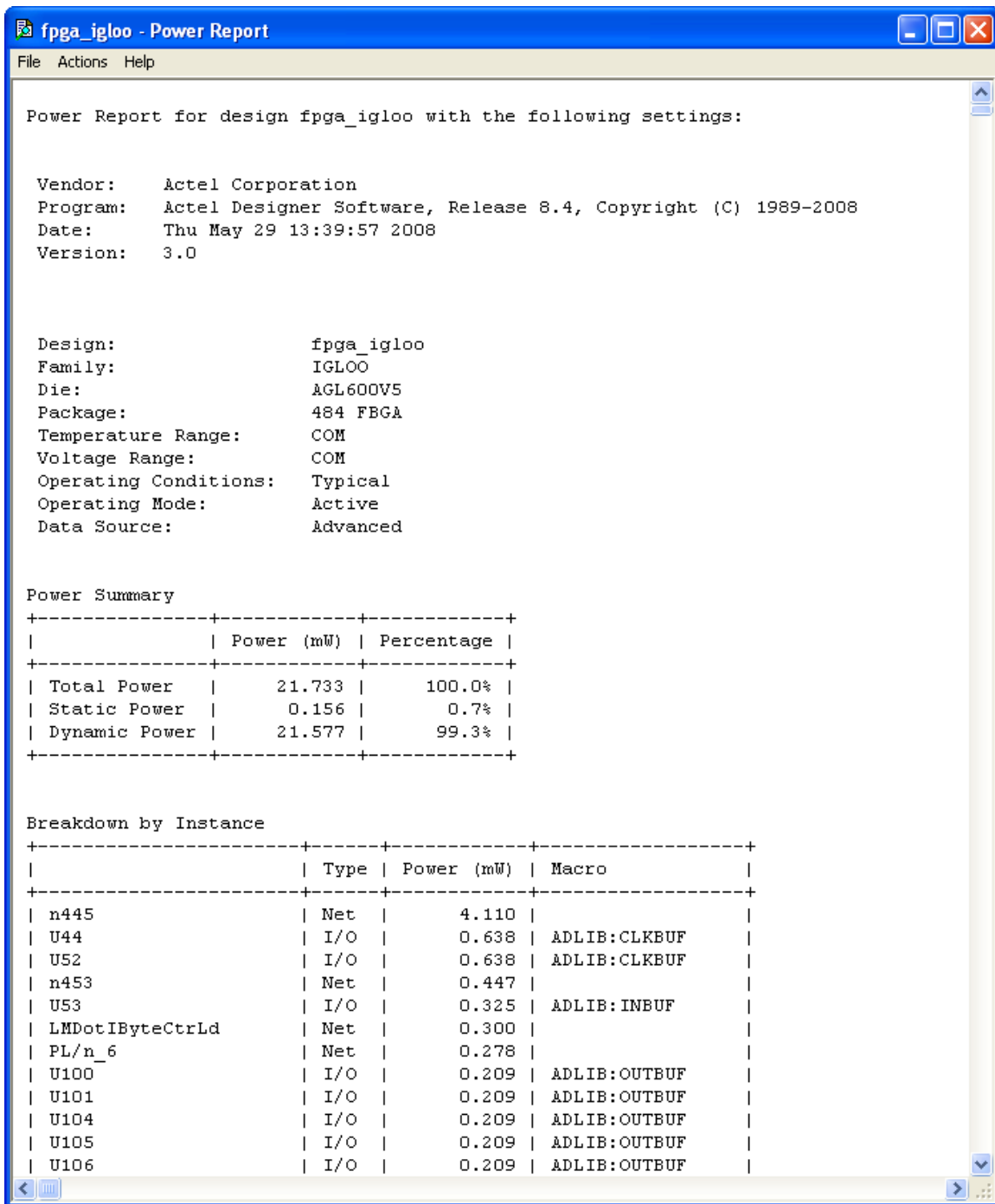

Figure 78 · SmartPower Report

In addition to the information selected on the **Power Reports** dialog box, the report contains global design information.

**Global design information:** This section shows the target family, the package and the die. It also shows information about the operating conditions, speed grade, and power mode. This option is set by default.

## See Also

[Report \(Power\)](#)

# Cycle-Accurate Power Reports

Traditional power analysis based on a VCD simulation file reports an average power for the entire simulation time. Based on a VCD simulation file, the cycle-accurate power analysis will report one power value per clock period (or half-period) instead of an average power for the whole simulation. This feature allows to easily identify the worst cycle in terms of power performance; and helps to understand and further minimize power consumption by facilitating the analysis of data-dependent power variations, as well as dynamic power variations due to clock-gating, or even clock frequency variations.

### **To generate a cycle-accurate power report:**

1. From the Designer **Tools** menu, choose **Reports > Power > Power Cycle Accurate**. The Cycle Accurate Power Report dialog box appears.
2. Select the options you want to include in the report, and then click **OK**. The cycle accurate power report appears in a separate window.

You can also generate the cycle accurate power report from within SmartPower. From the **Tools** menu, choose **Reports > Cycle Accurate Power Report** to open the cycle accurate power report dialog box; or select a vcd file from the Modes and Scenarios toolbar, and from the right-click menu, select **Tools > Power Cycle Accurate**.

The cycle-accurate power report dialog box is organized in the following panels: [General](#), [Sampling Period](#), [Partial Parsing](#), [Top-Level Name](#), [Glitch Filtering](#), and [History Size Reduction](#).

## General

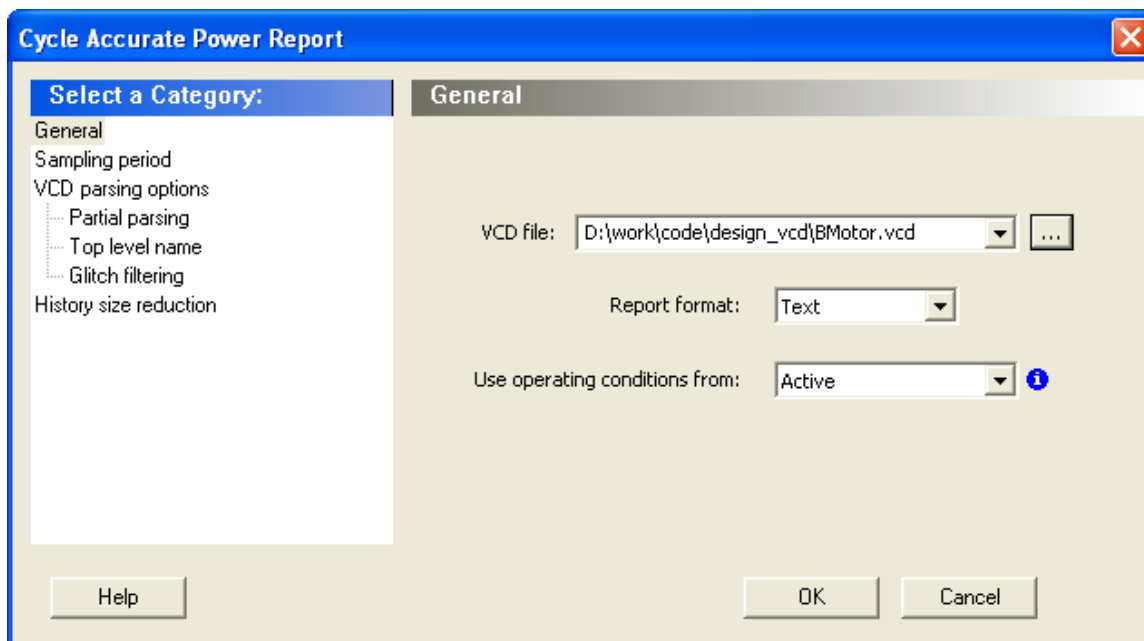

Figure 79 · SmartPower Cycle Accurate Power Report Dialog Box – General

**VCD file** - Select the VCD file you want to import.

**Report format** – Select **Text** or **CSV** (Comma Separated Value) as the desired export format.

**Use operating conditions from** – Select the mode from which the operating conditions will be used.



## Sampling Period

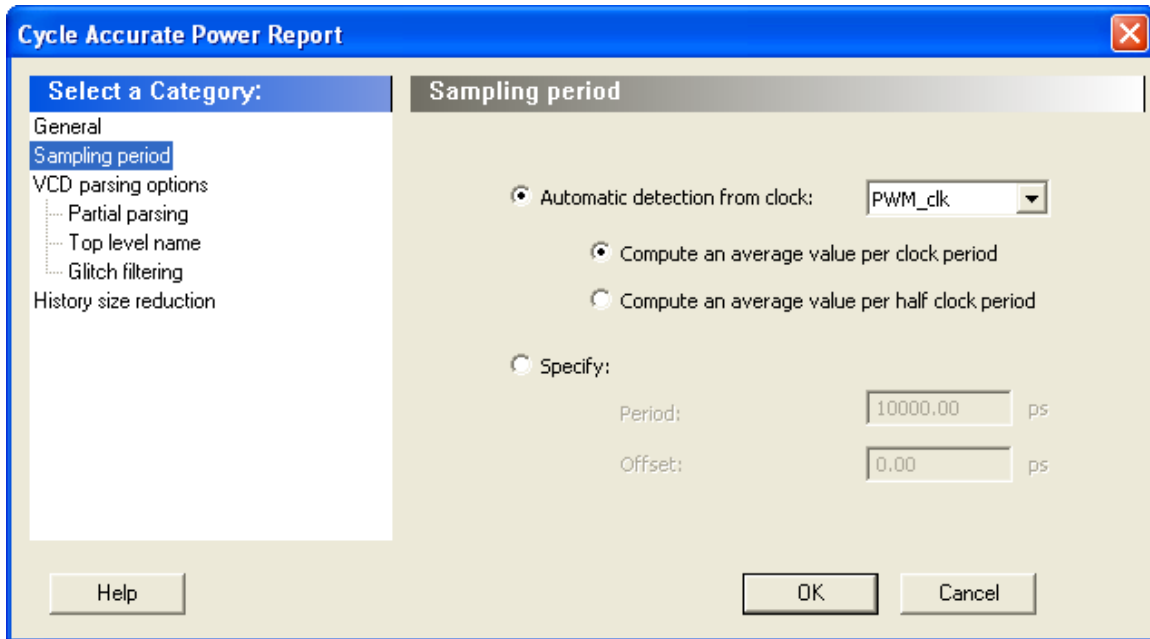

Figure 80 · SmartPower Cycle Accurate Power Report Dialog Box – Sampling Period

**Automatic detection from clock** – This option automatically detects the sampling period from the fastest clock. You can also select any other clock in your design. You can specify whether the average value is computed per period or half-period.

**Specify** – Select this option to specify the period and offset used to calculate the sampling period.

## Partial Parsing

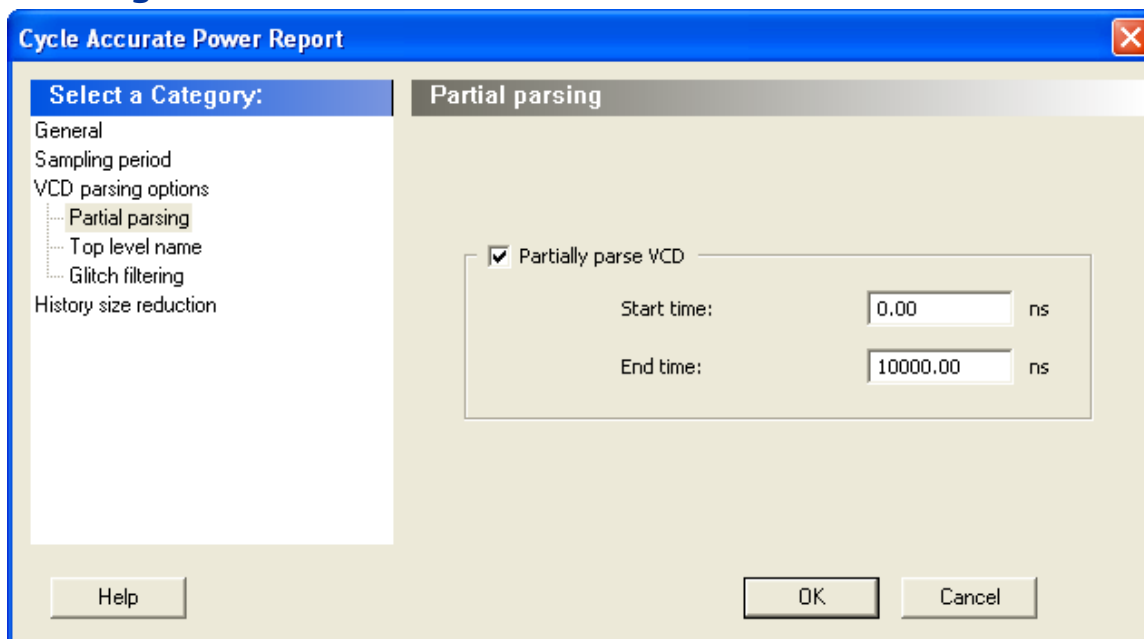

Figure 81 · SmartPower Cycle Accurate Power Report Dialog Box – Partial Parsing

**Partially parse VCD file** – Specify the Start and End times to partially parse the VCD file. This option can be used for large VCD files.

## Top-Level Name

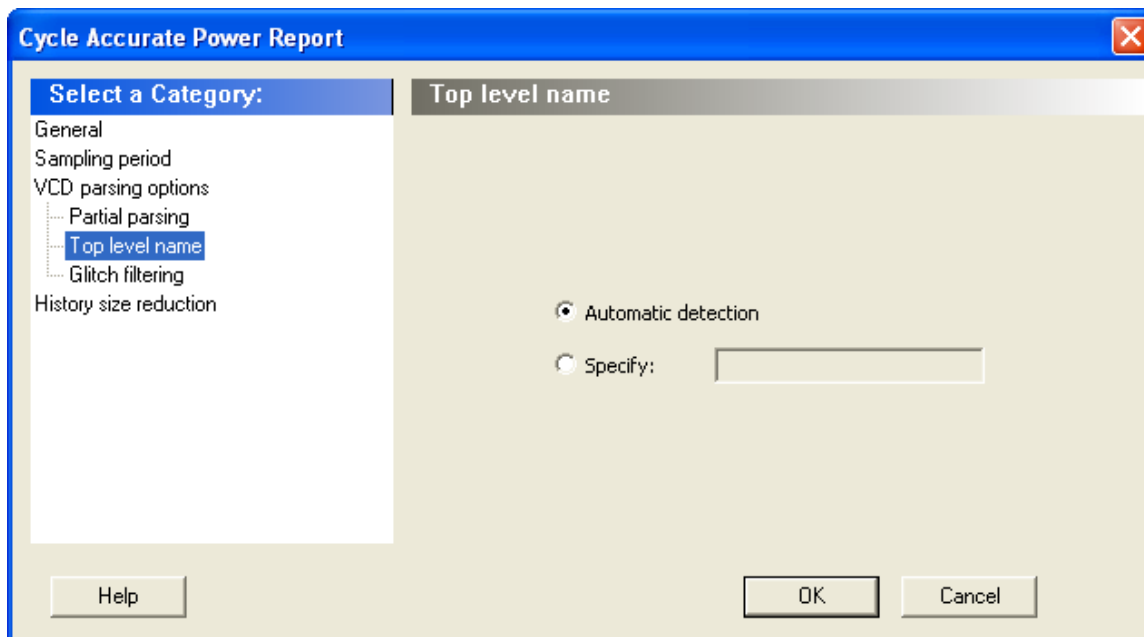

Figure 82 · SmartPower Cycle Accurate Power Report Dialog Box – Top-Level Name

This option enables you to select how the top-level name is specified. Select **Automatic Detection** to let the VCD reader automatically detect the top-level name of the design, or select **Specify** to manually specify the top-level name.

## Glitch Filtering

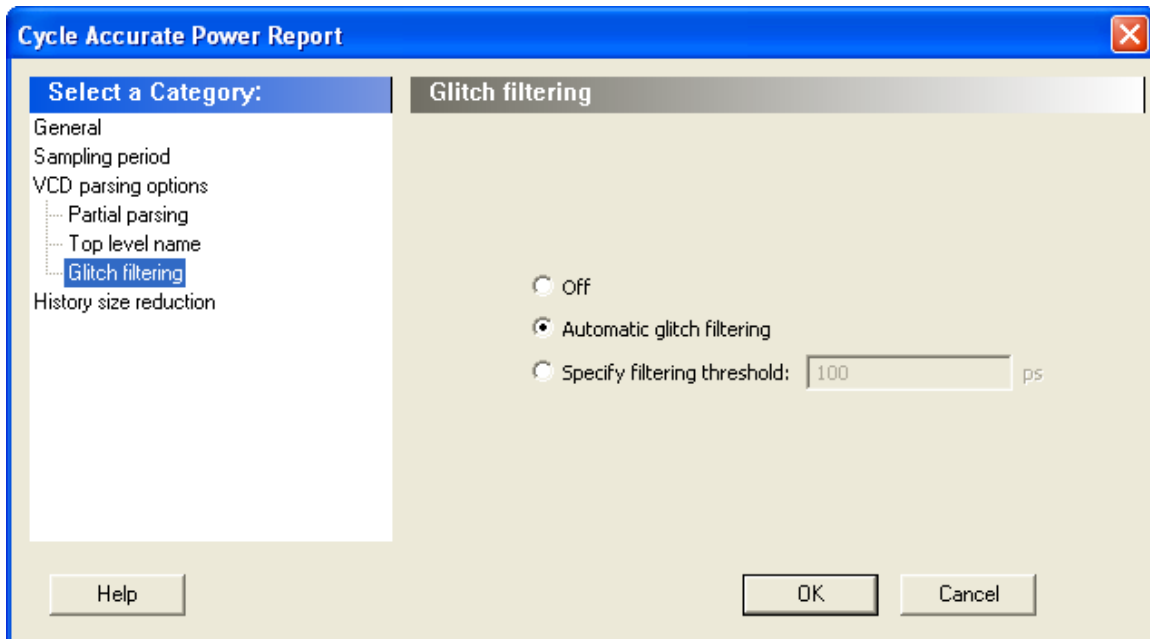

Figure 83 · SmartPower Cycle Accurate Power Report Advanced Options Dialog Box – Glitch Filtering

This panel enables you to filter out pulses of short durations by selecting **Automatic Glitch Filtering** or by entering a value in the **Specify Filtering Threshold** field. The default glitch filtering option is **Automatic Glitch Filtering**.

## History Size Reduction

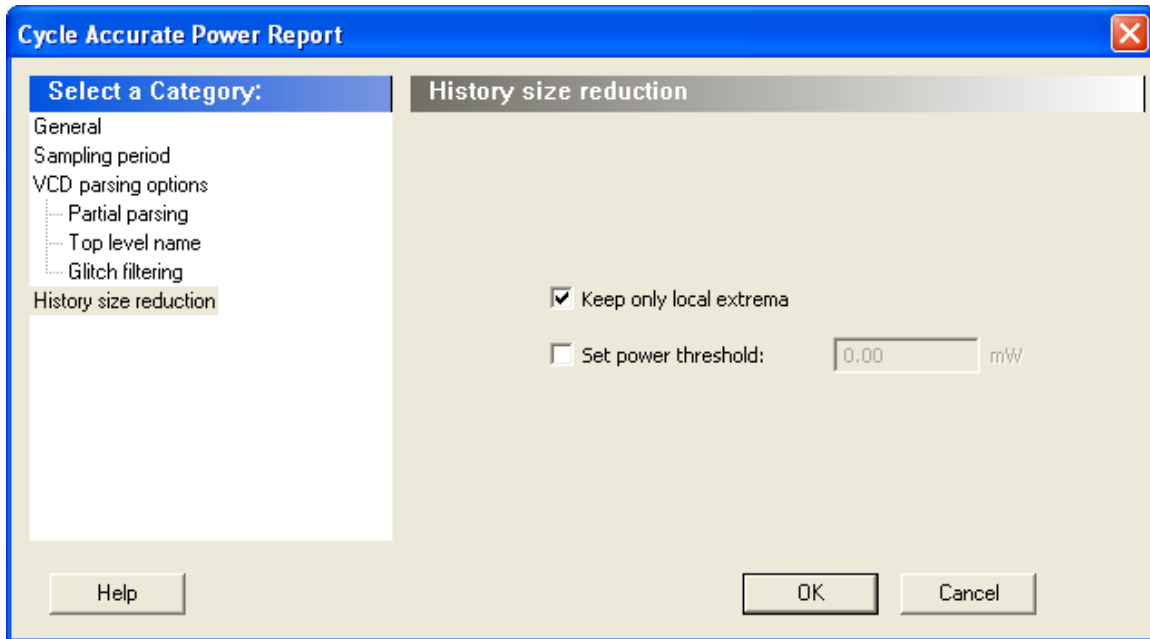

Figure 84 · SmartPower Cycle Accurate Power Report Advanced Options Dialog Box – History Size Reduction

This panel enables you to limit the history size by keeping only local extrema or setting a power threshold.

The results are displayed in the cycle accurate power report below.

```

simple_PWM_8 - Power_cycle_accurate Report
File Actions Help
Actel Corporation - Actel Designer Software Release 8.4 (Version 8.4.0.0)
Copyright (c) 1989-2008
Date: Thu May 29 13:53:58 2008

Design : simple_PWM_8
Family : IGLOO
Die : AGL600V2
Package : 256 FBGA
Temperature Range : COM
Voltage Range : COM
Operating Conditions : Typical
Operating Mode : Static
Data Source : Advanced

Vcd File: D:/work/code/design_vcd/BMotor.vcd

Max Power Report
+-----+-----+-----+-----+
| Cycle | Start Time (ps) | End Time (ps) | Power (mW) |
+-----+-----+-----+-----+
| 21    | 2000000         | 2100000       | 0.508      |
+-----+-----+-----+-----+

Cycle Based Power Report
+-----+-----+-----+-----+
| Cycle | Start Time (ps) | End Time (ps) | Power (mW) |
+-----+-----+-----+-----+
| 1     | 0               | 100000        | 0.101      |
| 2     | 100000          | 200000        | 0.161      |
| 11    | 1000000         | 1100000       | 0.161      |
| 13    | 1200000         | 1300000       | 0.207      |
| 16    | 1500000         | 1600000       | 0.182      |
| 17    | 1600000         | 1700000       | 0.203      |
| 18    | 1700000         | 1800000       | 0.180      |
| 21    | 2000000         | 2100000       | 0.508      |
| 22    | 2100000         | 2200000       | 0.180      |
| 23    | 2200000         | 2300000       | 0.188      |
| 24    | 2300000         | 2400000       | 0.182      |
| 25    | 2400000         | 2500000       | 0.199      |
| 26    | 2500000         | 2600000       | 0.180      |
| 29    | 2800000         | 2900000       | 0.238      |
| 30    | 2900000         | 3000000       | 0.180      |
| 31    | 3000000         | 3100000       | 0.188      |
| 32    | 3100000         | 3200000       | 0.182      |
+-----+-----+-----+-----+

```

Figure 85 · SmartPower Cycle Accurate Power Report

## Activity and Hazards Reports

Traditional Power Analysis based on a VCD simulation file reports an average power value that will account for all nets switching in the design. This switching includes functional transitions and spurious transitions. Due to the delay of each gate, paths arriving at one internal gate may have different propagation delays. Therefore, a gate may exhibit

multiple spurious transitions before settling to the correct logic level. The Activity and Hazards Power Report allows to quickly identify gates and nets of the design that consume power because of spurious transitions. This is helpful to understand and further minimize power consumption. The activity and hazards report reads a VCD file and reports transitions and hazards for each clock cycle of the VCD file.

**To generate an activity and hazards power report:**

1. From the Designer **Tools** menu, choose **Reports > Power > Power Activity and Hazards**. The Activity and Hazards Power Report dialog box appears.
2. Select the options you want to include in the report, and then click **OK**. The activity and hazards report appears in a separate window.

You can also generate the activity and hazards report from within SmartPower. From the **Tools** menu, choose **Reports > Activity and Hazards Report**; or select a vcd file from the Modes and Scenarios toolbar, and from the right-click menu, select **Tools > Power Activity and Hazards**

The activity and hazards report dialog box is organized in the following panels: [General](#), [Partial Parsing](#), [Top-Level Name](#), [Glitch Filtering](#), and [Clock Domains](#).

## General

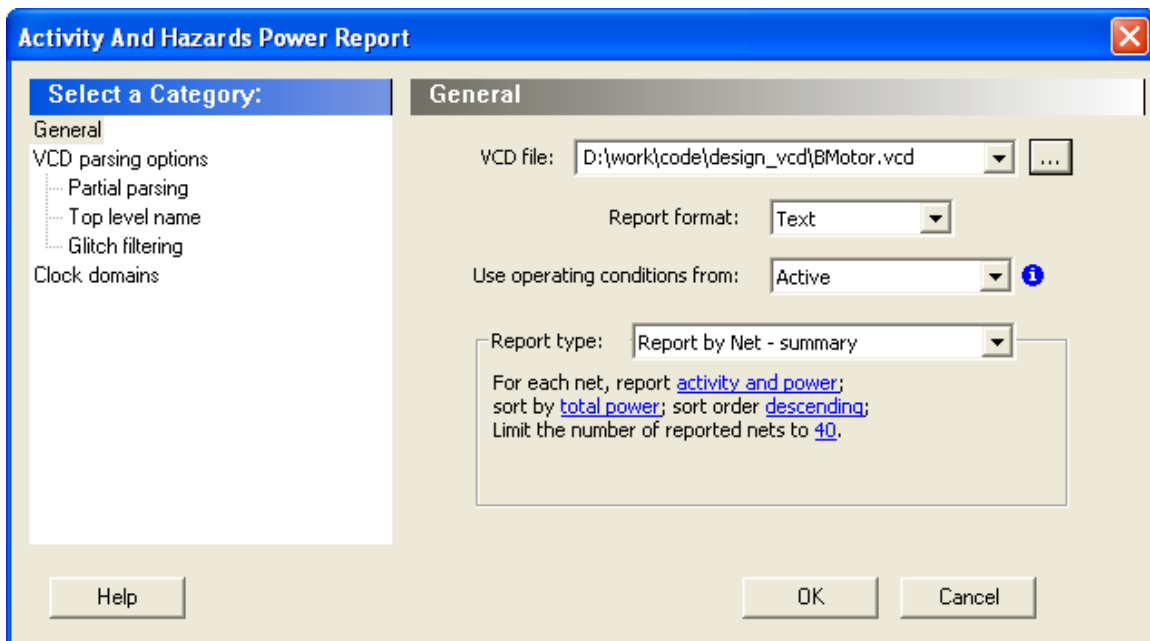

Figure 86 · SmartPower Activity and Hazards Report Dialog Box – General

**VCD file** – Select the VCD file you want to import.

**Report format** – Select **Text** or **CSV** (Comma Separated Value) as the desired export format.

**Use operating conditions from** – Select the mode from which the operating conditions will be used.

**Report type** – Select the report type:

- Report by net – summary: summary report by net
- Report by net – detailed: detailed report by cycle
- Report by cycle – summary: summary report by net
- Report by cycle – detailed: detailed report by cycle

The selected report type reports activity and power for each net sorted by power in descending order and limits the number of reported nets to 20 by default. To change these options, click each option and from the pop-up menu, select the desired option:

- Report: Select the query report type: activity, power, or activity and power.
- Sort by: Select the query sort by functional power, functional transitions, spurious power, spurious transitions, or total power.
- Sort order: Select the query sort order: ascending or descending.
- Limit the number of reported nets: Enter the query filter limit.

## Partial Parsing

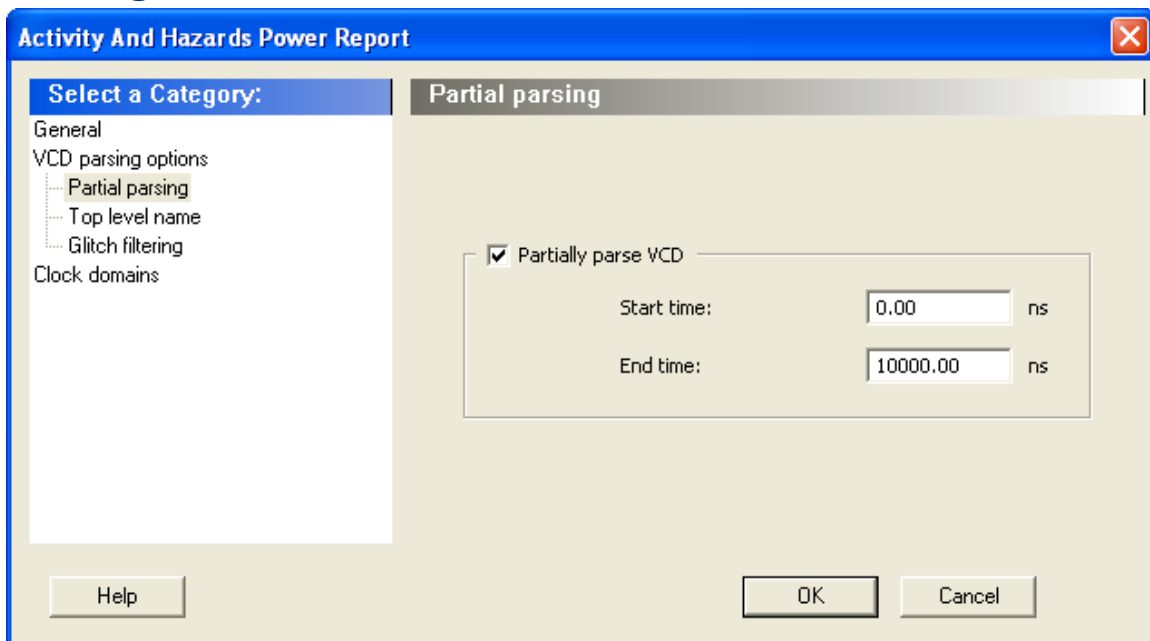

Figure 87 · SmartPower Activity and Hazards Report Dialog Box – Partial Parsing

**Partially parse VCD file** – Specify the Start and End times to partially parse the VCD file. This option can be used for large VCD files.

## Top-Level Name

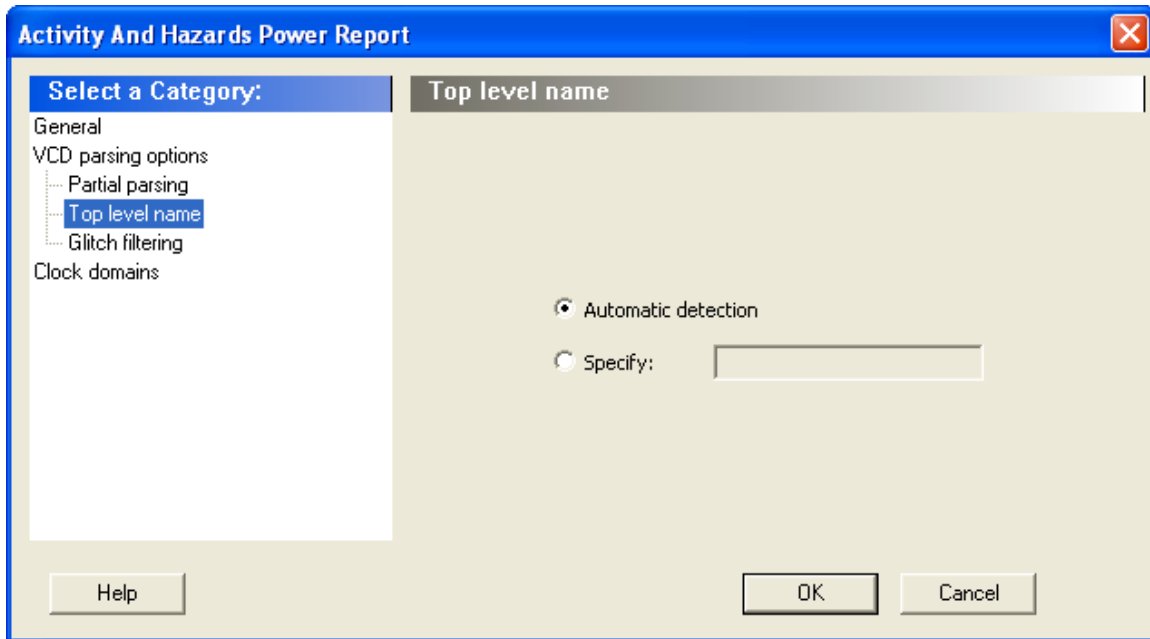

Figure 88 · SmartPower Activity and Hazards Report Dialog Box – Top-Level Name

This option enables you to select how the top-level name is specified. Select **Automatic Detection** to let the VCD reader automatically detect the top-level name of the design, or select **Specify** to manually specify the top-level name.



## Glitch Filtering

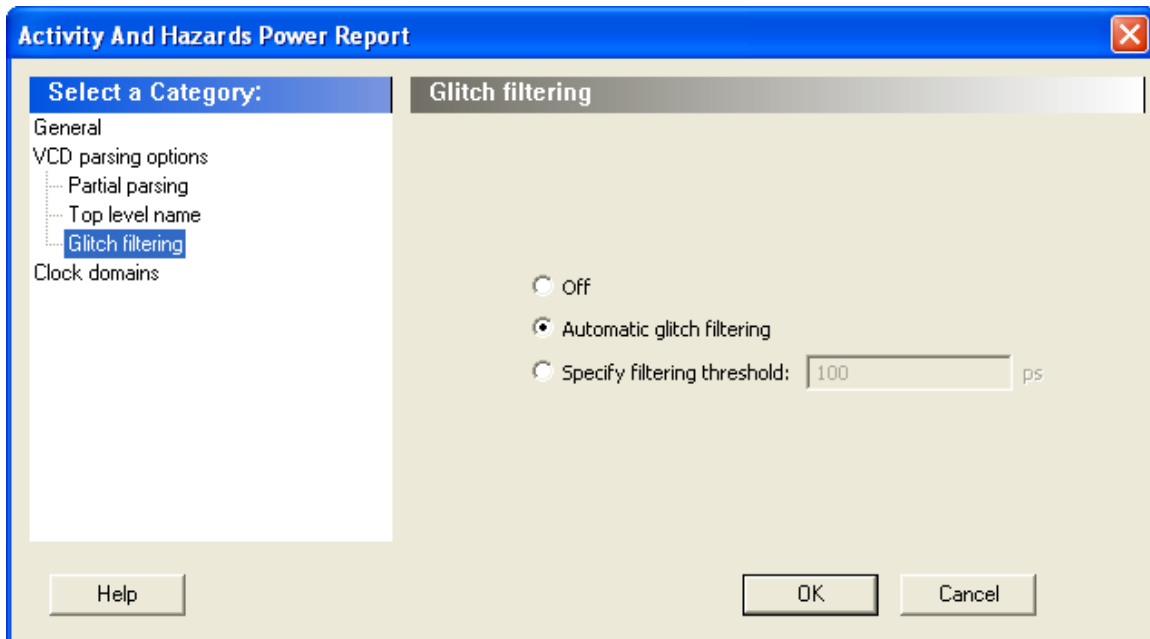

Figure 89 · SmartPower Activity and Hazards Report Advanced Options Dialog Box – Glitch Filtering

This option enables you to filter out pulses of short durations by selecting **Automatic Glitch Filtering** or by entering a value in the **Specify Filtering Threshold** field. The default glitch filtering option is **Automatic Glitch Filtering**.

## Clock Domains

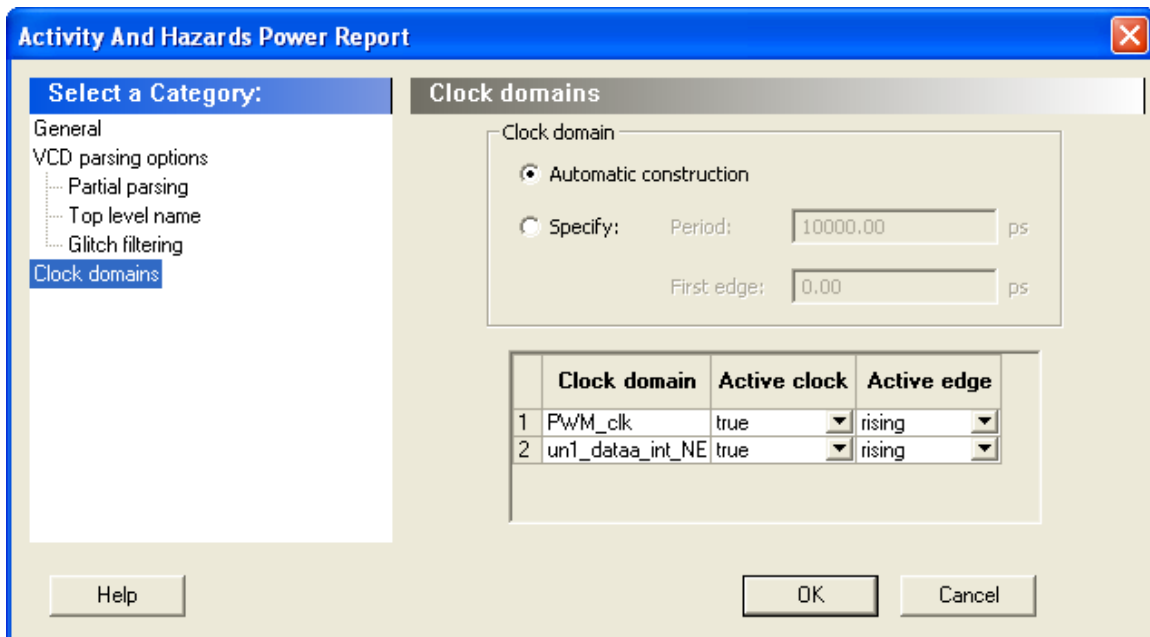

Figure 90 · SmartPower Activity and Hazards Report Advanced Options Dialog Box – Clock Domains

The clock domain can be automatically constructed or it can be specified by the user.

**Automatic construction** – This option automatically constructs the clock domain. SmartPower automatically analyzes your design to assess if a clock is active and what is the active edge.

**Specify** – Select this option to specify the period and first edge.

Use the clock domain table to set the active edge (rising, falling or both) and to set a clock as transparent.

The results are displayed in the activity and hazards power report below.

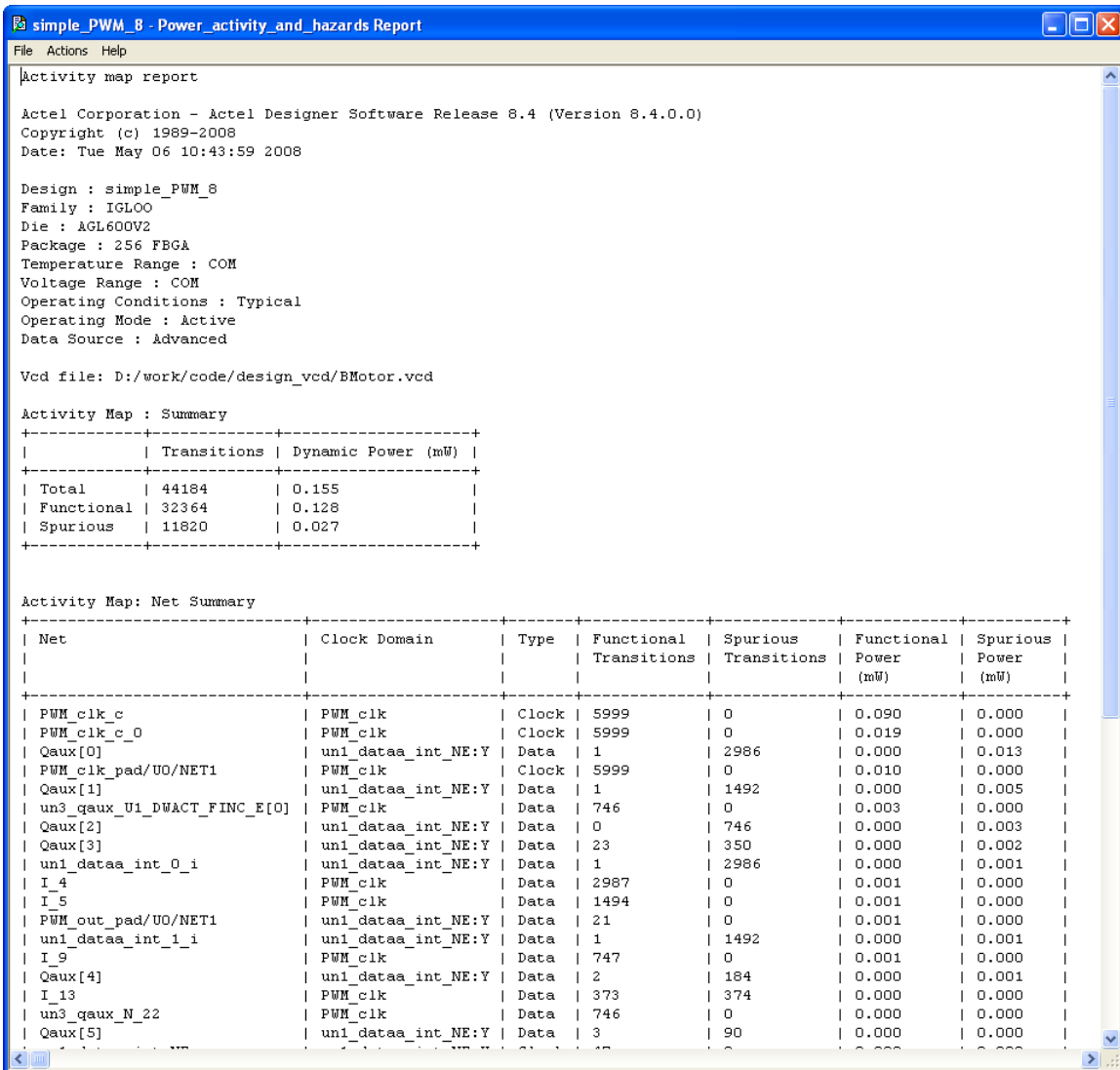

Figure 91 · SmartPower Activity and Hazards Report

## Scenario Power Report

The scenario power report enables you to select a previously defined [scenario](#) and calculate the average power consumption and the battery life for this scenario.

### To generate a scenario power report:

**Note:** Note: In order to generate a scenario power report, your design must contain one or more [scenarios](#).

1. From the Designer **Tools** menu, choose **Reports > Power > Power Scenario**. The Scenario Power Report dialog box appears.
2. Select the options you want to include in the report, and then click **OK**. The scenario power report appears in a separate window.

You can also generate the scenario power report from within SmartPower. From the **Tools** menu, choose **Reports > Scenario Power Report**, or click the **Scenario Power Report** button to open the Power Scenarios dialog box. By default, the report includes global design information and power sequencer summary. Specify which results you want to display by checking the boxes to be included in the report.

The power report dialog box is organized in the following panels: [General](#), [Operating Conditions](#), [Options](#), and [Battery Life](#).

### General

The general panel enables you to select what to include in the report, the report format, and the scenario you want to generate the report for.

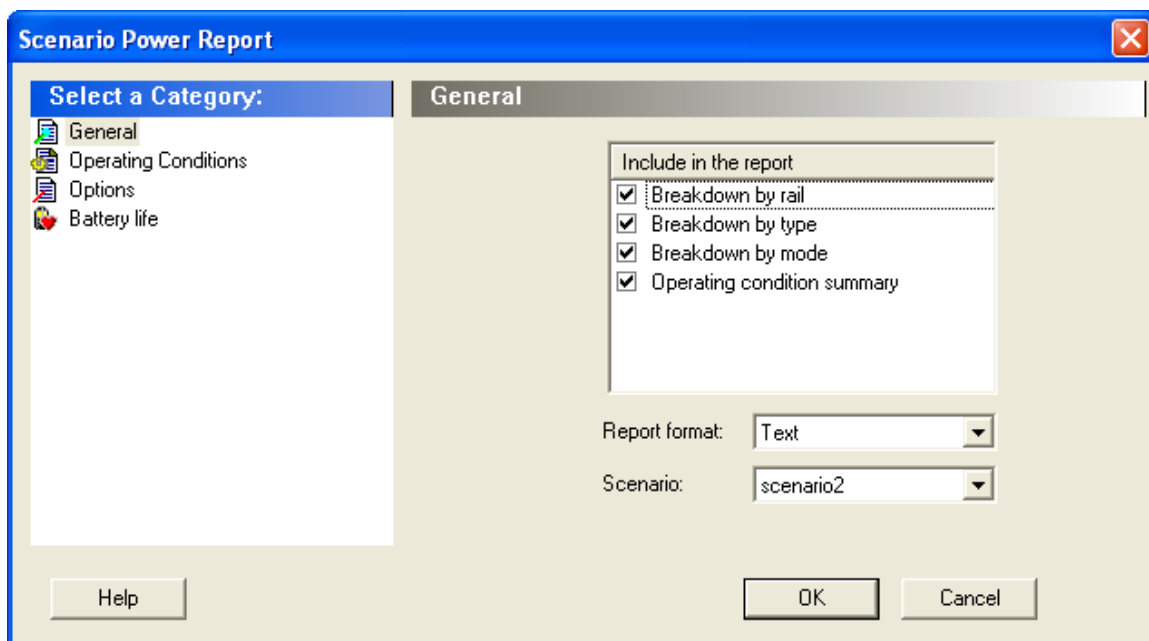

Figure 92 · SmartPower Scenario Power Report Dialog Box – General Panel

### Include in the Report

**Breakdown by Rail** – This section shows the power consumption of each rail.

**Breakdown by Type** – This section enables reporting on the power consumption according to: gates, nets, clocks, core static, IOs, and memories.

**Breakdown by Mode** – This section enables reporting on the power consumption by mode.

**Operating Condition Summary** – This section reports the operating conditions.

### Report Format

Select **Text** or **CSV** (Comma Separated Value) as the desired export format.

### Scenario

Select a previously defined [scenario](#) to generate the report from.

## Operating Conditions

The Operating Conditions panel enables you to select the operating conditions case for the current design.

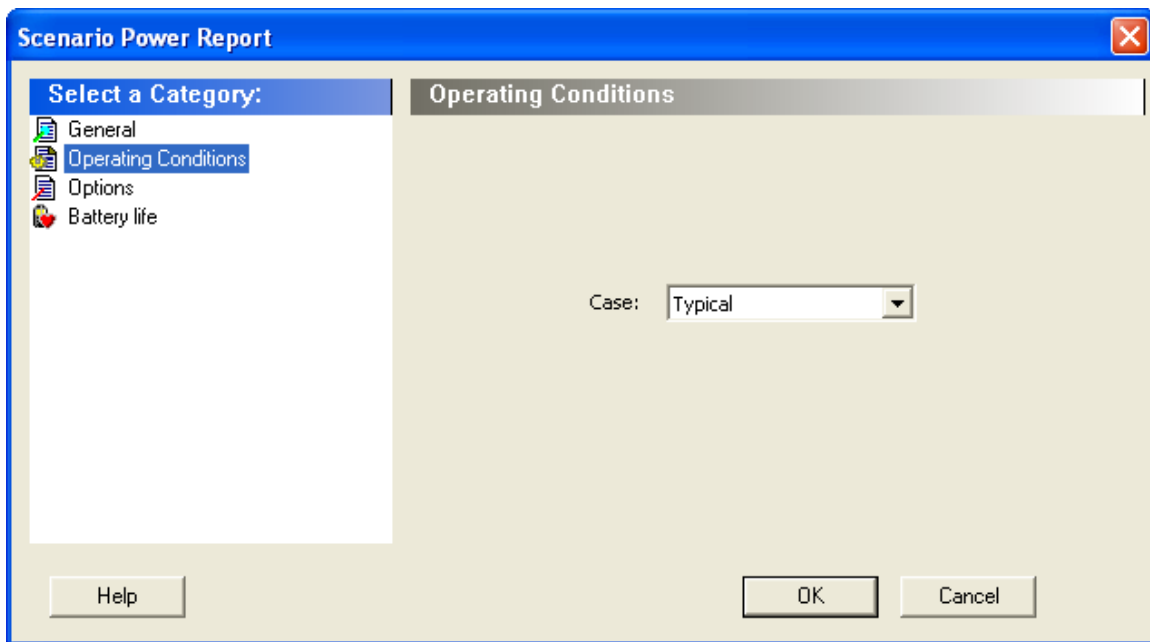

Figure 93 · SmartPower Scenario Power Report Dialog Box – Operating Conditions Panel

## Options

The Options panel enables you to select power and frequency units and to use toggle rates.

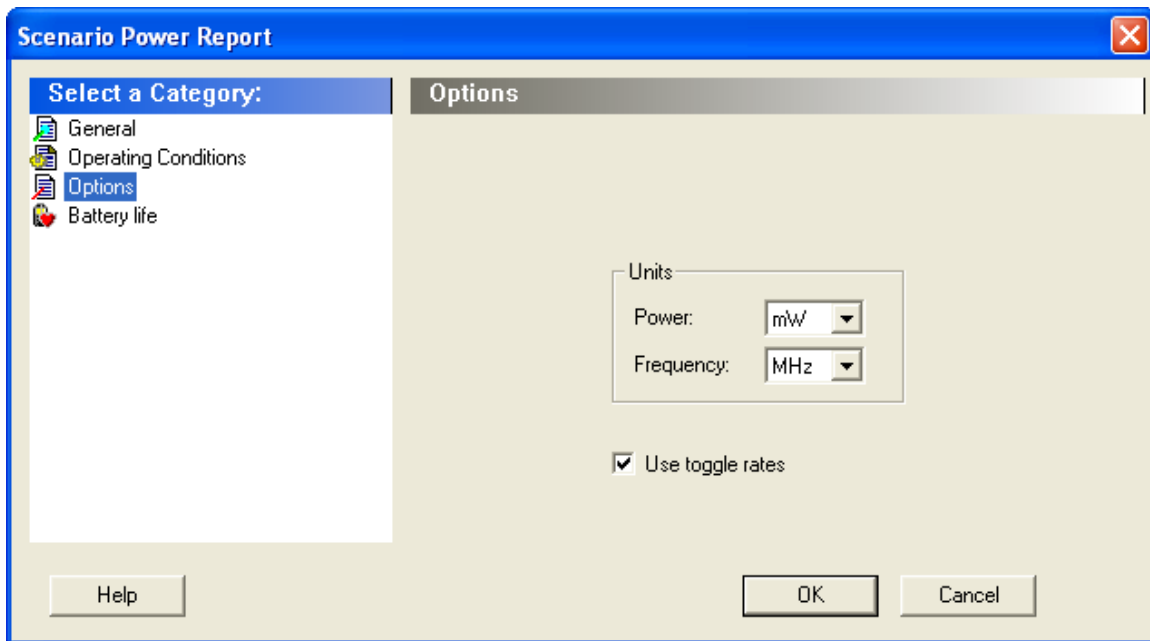

Figure 94 · SmartPower Scenario Power Report Dialog Box – Options Panel

### Units

**Frequency:** Sets unit preferences for frequency – Hz, KHz, MHz.

**Power Units:** Sets unit preferences for power – W, mW, or  $\mu$ W.

### Use Toggle Rates

When toggle rates are active (**Use Toggle Rates** box is checked), the data frequency of all the clock domains is defined as a function of the clock frequency. This updates the data frequency automatically when you update the clock frequency. Toggle rates enable you to specify the data frequency as a percentage of clock frequency, but you can no longer specify the data frequency as a number, only as a percentage of the clock frequency. To set the data frequency again, clear the **Use Toggle Rates** option.

## Battery Life

The Battery Life panel enables reporting of the battery capacity and the battery life. Enter a battery capacity in MA/Hrs.

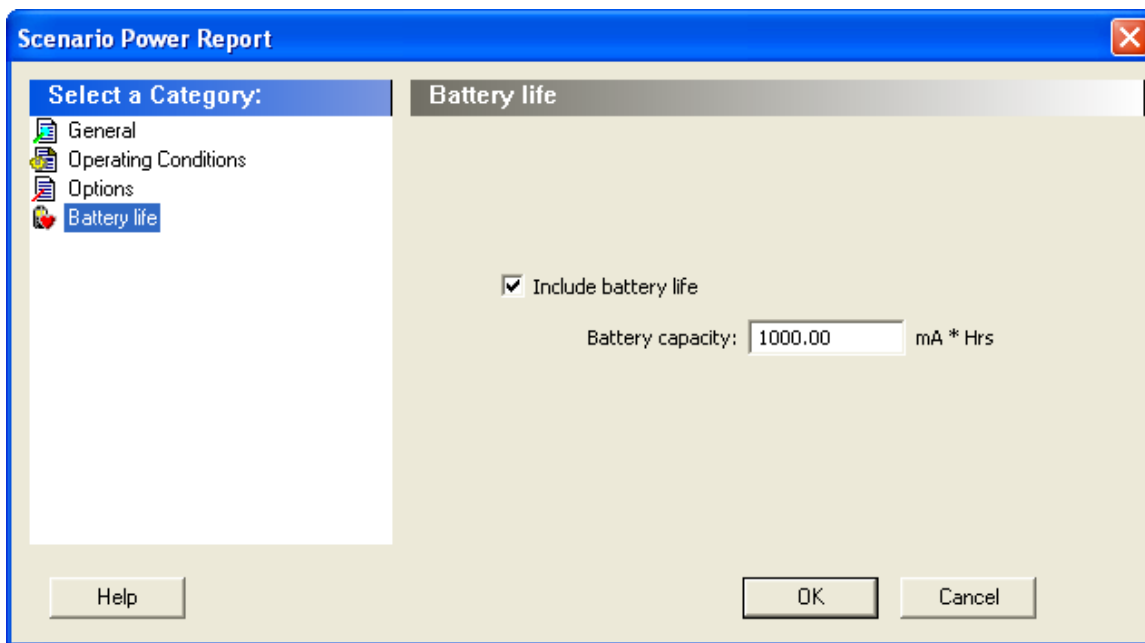

Figure 95 · SmartPower Scenario Power Report Dialog Box – Battery Life Panel

The SmartPower scenario power report returns the average power consumption and battery life for this sequence.

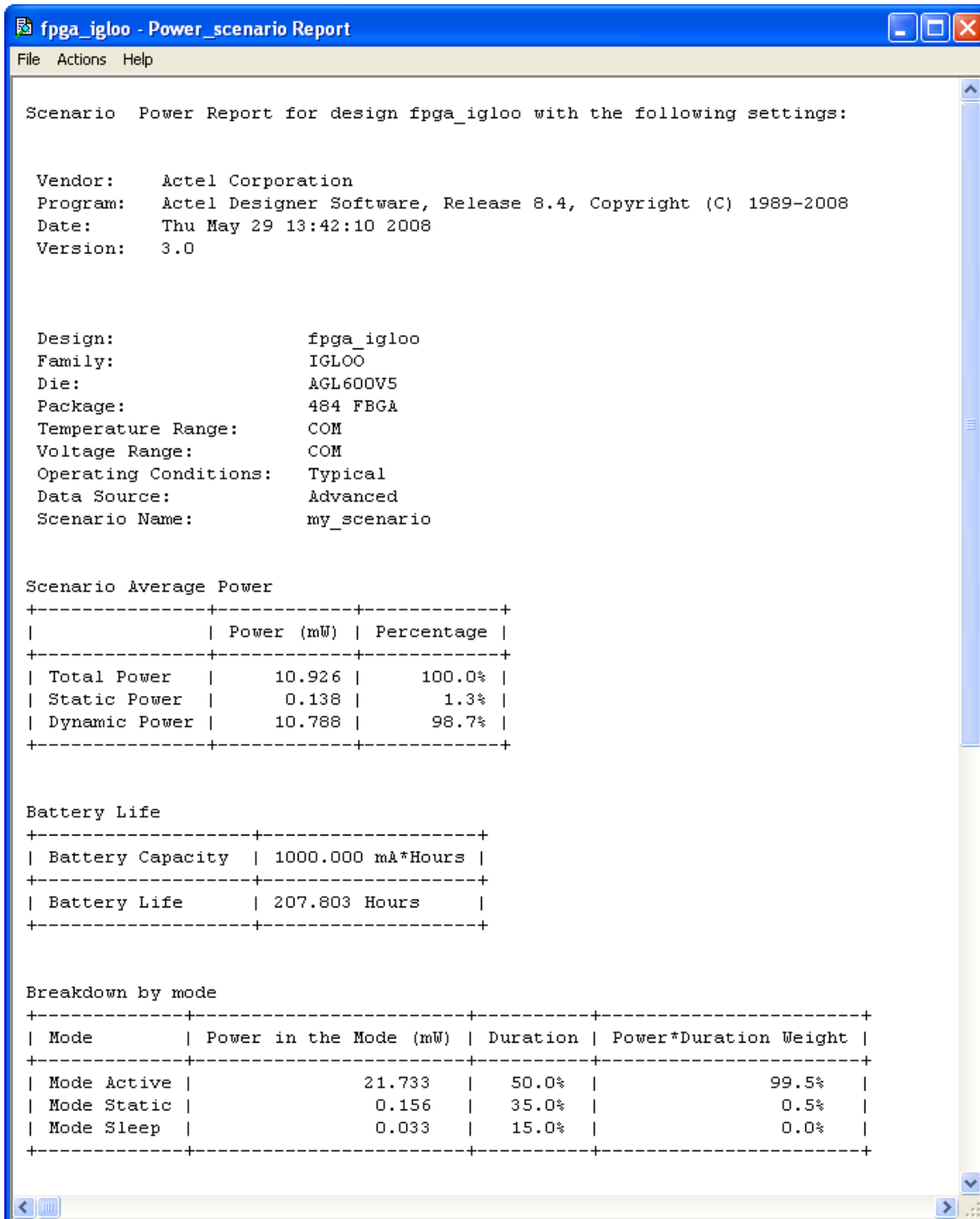

Figure 96 · SmartPower Scenario Power Report

In addition to the information selected on the **Scenario Power Reports** dialog box, the report contains global design information, a mode summary and the sequence average power.

**Global design information:** This section shows the target family, the package and the die. It also shows information about the operating conditions, speed grade and power mode. This option is set by default.

**Power Summary:** This section reports the power consumption of the sequence by mode. This option is set by default.

**Sequence Average Power:** This section reports the average power consumption of the sequence. This option is set by default.

**See Also**

[Report \(Sequencer\)](#)

## CCC Configuration report

The [Fusion Dynamic CCC](#) (DYNCCC) and [ProASIC3E Dynamic CCC](#) prints out all the values of the configuration pins in a report. You can use these to specify the bitstream that can be shifted in via the shift register.

To view the CCC Configuration report, from the Tools menu, choose Reports > Global > CCC\_configuration.

The CCC Configuration report for Fusion has some signal names that do not appear in the ProASIC3E report. A sample Fusion DYNCCC report is shown below:

```

*****
                        Dynamic Stream Data
*****

Product: Designer
Release: 7.2
Version: 7.2.0.13
Date   : Thu Apr 13 14:48:21 2006
Design Name: AFS600_dynpll_rc_a100_ybycout  Family: Fusion  Die: AFS600  Package: Fully
Bonded Package
Location: MIDDLE_LEFT
Instance: Core                                DEF Name: DYNCCC
        Core/U_P0  (1,40)
        Core/U_PLL (2,40)
        Core/U_GLB (1,41)
        Core/U_GLC (2,41)
        Core/U_P4  (1,42)

-----
NAME      SDIN      VALUE      TYPE
-----
FINDIV    [ 6: 0]    0010011    EDIT
FBDIV     [13: 7]    0001011    EDIT
OADIV     [18:14]    00011      EDIT
OBDIV     [23:19]    00001      EDIT
OCDIV     [28:24]    00000      EDIT
OAMUX     [31:29]    101        EDIT
OBMUX     [34:32]    111        EDIT
OCMUX     [37:35]    110        EDIT

```



FBSEL	[39:38]	10	EDIT
FBDLY	[44:40]	10100	EDIT
XDLYSEL	[45]	1	EDIT
DLYGLA	[50:46]	01001	EDIT
DLYGLB	[55:51]	00000	EDIT
DLYGLC	[60:56]	00000	EDIT
DLYYB	[65:61]	10001	EDIT
DLYYC	[70:66]	11100	EDIT
STATASEL	[71]	1	MASKED
STATBSEL	[72]	1	MASKED
STATCSEL	[73]	1	MASKED
VCASEL	[76:74]	010	EDIT
DYNASEL	[77]	0	MASKED
DYNBSEL	[78]	1	MASKED
DYNCSEL	[79]	1	MASKED
RESETEN	[80]	1	READONLY
RXASEL	[81]	0	MASKED
RXBSEL	[82]	0	MASKED
RXCSEL	[83]	0	MASKED
OADIVHALF	[84]	0	EDIT
OBDIVHALF	[85]	0	EDIT
OCDIVHALF	[86]	0	EDIT
GLMUXCFG	[88:87]	00	MASKED

A sample ProASIC3E DYNCCC report is shown below.

```
*****
                        Dynamic Stream Data
*****
```

```
Product: Designer
Release: 7.2
Version: 7.2.0.0
Date   : Tue May 02 15:50:01 2006
Design Name: dynccc Family: Proasic3E Die: A3PE600 Package: Fully Bonded Package
Location: MIDDLE_RIGHT
Instance: I_dynccc DEF Name: DYNCCC
        I_dynccc/U_DYN (196,40)
        I_dynccc/U_PLL (195,40)
        I_dynccc/U_GLB (196,41)
        I_dynccc/U_GLC (195,41)
```

NAME	SDIN	VALUE	TYPE
FINDIV	[ 6: 0]	1100101	EDIT
FBDIV	[13: 7]	0000110	EDIT
OADIV	[18:14]	00101	EDIT
OBDIV	[23:19]	00101	EDIT
OCDIV	[28:24]	00101	EDIT

OAMUX	[ 31:29 ]	101	EDIT
OBMUX	[ 34:32 ]	101	EDIT
OCMUX	[ 37:35 ]	101	EDIT
FBSEL	[ 39:38 ]	00	EDIT
FBDLY	[ 44:40 ]	00110	EDIT
XDLYSEL	[ 45 ]	0	EDIT
DLYGLA	[ 50:46 ]	00101	EDIT
DLYGLB	[ 55:51 ]	10001	EDIT
DLYGLC	[ 60:56 ]	10001	EDIT
DLYYB	[ 65:61 ]	00101	EDIT
DLYYC	[ 70:66 ]	00101	EDIT
STATASEL	[ 71 ]	1	MASKED
STATBSEL	[ 72 ]	1	MASKED
STATCSEL	[ 73 ]	1	MASKED
VCOSEL	[ 76:74 ]	000	EDIT
DYNASEL	[ 77 ]	0	MASKED
DYNBSEL	[ 78 ]	0	MASKED
DYNCSEL	[ 79 ]	0	MASKED
RESETEEN	[ 80 ]	1	READONLY

## report (Global Usage)

Creates a report containing information about the net(s) that are assigned or routed using Global or LocalClock resources.

```
report -type globalusage filename
```

### Arguments

`-type globalusage`

Specifies the type of report to generate.

`filename`

Specifies the name and destination of the generated Global Usage report.

### Supported Families

ProASIC<sup>PLUS</sup>, ProASIC

### Exceptions

- None

### Examples

This example generates a Global Usage report and saves it to a file named `globalusage_rpt.txt`:

```
>report -type globalusage globalusage_rpt.txt
```

### See Also

[Global Usage report](#)

[Tcl documentation conventions](#)

## Global Usage report

The Global Usage report provides information about the net(s) that are assigned or routed using Global or LocalClock resources.

You can generate this report in either pre or post route state of the design.

In pre-routed state, the Global Usage report displays the following information:

- Net(s) assigned to Global resources
- Net(s) assigned to LocalClock resources

In post-routed state, the Global Usage report displays the following information:

- Net(s) that are routed using Global resources
- Net(s) that are routed using LocalClock resources
- Net(s) that are constrained to use LocalClock resources but routed using Regular resources. In this case, the tool displays a warning message at the end of the report.

### To create a Global Usage report:

From the **Tools** menu, choose Reports > Global > GlobalUsage.

### See Also

[report \(Global Usage\) Tcl command](#)

## Designer Block Report

The Designer Block report is available in **Tools > Reports > Block**. It includes a compile, global, datasheet, and interface report and Designer Block-related information.

The block reports are available in the Project Manager Files tab after you generate your block and instantiate it in your project. Double-click the report to view the contents.

In the Project Manager there is a header\_report.log that contains only the options used to generate the block. This information is available in each report you generate from the Designer > Tools menu.

## Compile

Use it to evaluate resources and manage the globals in the other blocks and the <top> design (if necessary).

## Datasheet

Lists block timing and I/O placement information. If the block is preserved during instantiation (both placement and routing) you can expect to get the same results as are shown in this report.

## Global

Lists global usage in the block. Useful if you want to evaluate the globals used by the block / manage globals in the overall design.

## Interface

The Interface section lists:

- Connection information for interface macros connected to the block ports
- Block placement information, including each port and its fanout, type (pad, clock, global, etc.), direction, and name
- Information on legal move locations, useful if you are instantiating multiple blocks in one design

## Compile report

The Compile Report appears in the Designer Log window after compile is complete. It is divided into the following sections:

### Parameters used to run Compile

All the information about the design, including the device selection and compile options used to run compile. Some options are not shown if you did not select them; for example, if the option `demote_globals` is OFF than the option `demote_globals_max_fanout` does not appear in the report.

### Warnings, Errors, and the Netlist Optimization Report

Lists any warnings or errors encountered during compile. Also contains the Netlist Optimization report that lists out the optimized macros (deleted blocks) in your design.

### Reading user pdc (Physical Design Constraints) file(s) postcompile

Lists out any PDC related errors and warnings encountered during compile.

### Compile Report - Device utilization report

The Device Utilization Report includes the following:

- Complete device utilization: Summary for all the resources used in the final optimized netlist.
- Global Information: Describes the number of chip and quadrant clocks in the design and the device.
- Core Information: Describes the total number of macros in the netlist and how many tiles they are using.

- I/O function: Detailed information about I/O's, such as how many Diff I/Os exist in the netlist, etc.
- I/O Technology: Summary of I/O technology used in the netlist.
- I/O Bank Resource Usage: Summarizes each I/O bank, including details on voltages, I/O pairs, Vref I/Os, Vref Pins, etc.
- I/O Voltage Usage: Lists I/Os by voltage used in the netlist and device resources available for each voltage (using the iobank and placement information).

## Net information report

The section may not appear if there is no net to report. The Net Information Report includes the following sections:

- List of nets that drive enable flip-flops that have been remapped to a 2-tile implementation
- List of nets that have been assigned to a chip global resource
- List of nets that have been assigned to a quadrant global resource
- List of nets that nets have been assigned to a LocalClock resource using PDC constraints
- High fanout nets in the post-compile netlist
- Nets that are candidates for clock assignment and the resulting fanout

**Note:** Note: If the driver macro of a clock net is fixed in a quadrant clock location then this net will show in the quadrant clock net report.

**Note:** The number of clock nets (chip+quadrant) can be less than the number reported in the device utilization (such as in the case of PLL using a YB and not the GLB).

### Net Information Report Types

INT\_NET - Internal nets

CLK\_NET - More than 75% of pins driven by this net are clock pins

SET/RESET\_NET - More than 75% of pins driven by this net are set or reset pins

### Net Information Source Types:

NETLIST - Clock from the netlist

PDC PROMOTED - Promoted because of a PDC constraint

AUTO PROMOTED - Promoted automatically by compile; change the compile options if you do not want to promote this net.

ESSENTIAL - Global clock from the netlist that cannot be demoted (such as the PLL or CLKBIBUF).

### Net Information Report Region (Definition)

The region is the clock region for the local and quadrant clocks. For example,

Local clock regions chip\_T1, chip\_T2:B5, quadrant\_T1

The quadrant clock regions list is as follows: quadrant\_UL, quadrant\_UR, quadrant\_LL, quadrant\_LR

## **Block information report**

This section lists the name of the module, the name of the instance, the number of macros and nets used in your block(s), and information on how conflicts between blocks were resolved (if any).

## Device Programming

Once you have completed your design, and you are satisfied with the back-annotated timing simulation, create your programming file. Depending upon your device family, you need to generate a [Fuse](#), [Bitstream](#) or [STAPL](#) programming file.

IGLOO, ProASIC3, SmartFusion and Fusion devices use the FlashPoint program file generator to create a programming file. The FlashPoint interface enables the advanced security features in all three device families.

Programmer	Antifuse Programming File	Flash Programming File
FlashPro4/3/3x	N/A	*.stp
Silicon Sculptor I	*.afm (Non-Axcelerator families)	*.bit
Silicon Sculptor II	*.afm	*.bit *.stp (Windows only)

## Starting Silicon Sculptor from Libero IDE

Before starting Silicon Sculptor, generate your [programming file](#).

### **To start the programming tool software:**

1. Right-click the design root file in the **Hierarchy** tab.
2. Click **Run Silicon Sculptor**. Refer to the Silicon Sculptor User's Guide for information on using the programming tool.

# Generating Programming Files

## Generate a Programming File in FlashPoint

FlashPoint enables you to program security settings, FPGA Array, and FlashROM features for IGLOO, ProASIC3, SmartFusion, Fusion, and ProASIC family devices. You can program these features separately using different programming files or you can combine them into one programming file. Each feature is listed as a silicon feature in the GUI.

**Note:** You can generate a programming file with one, two, or all of the silicon features from the Programming File Generator first page.

### To generate a programming file:

1. Select the **Silicon feature(s)** you want to program.
  - [Security settings](#)
  - [FPGA Array](#)
  - [FlashROM](#)

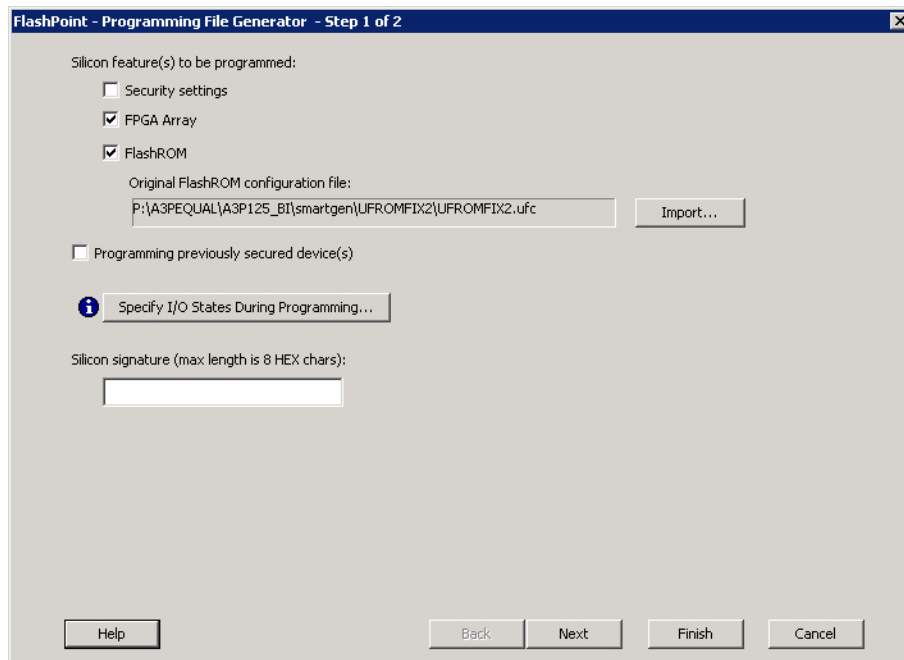

Figure 97 · Programming File Generator – Step 1 of 2

**Note:** Note: When FlashPoint is invoked for the first time, after netlist files are imported and the design is in post-layout state, the software retrieves the FlashROM and EFM blocks configuration files from the imported netlists and imports the configuration files. Otherwise, you need to import configuration files.



2. Click the **Programming previously secured device(s)** check box if you are reprogramming a device that has been secured.

Because the IGLOO, ProASIC3, SmartFusion, Fusion, and ProASIC families enable you to program the Security Settings separately from the FPGA Array and/or FlashROM, you must indicate if the Security Settings were previously programmed into the target device. This requirement also applies when you generate programming files for reprogramming.

3. Enter the silicon signature (0-8 HEX characters). See [Silicon Signature](#) for more information.
4. Depending upon the Silicon features you selected, click **Next** or **Finish**.

If you click **Next**, follow the instructions in the appropriate dialog box. If you click **Finish**, the **Generate Programming Files** dialog box appears (as shown in the figure below). Use this dialog box to specify the programming file name, location, output format ([STAPL file](#), [SVF file](#), [PDB file](#), [DirectC DAT file](#), [1532 file](#)), and, if necessary, limit the file size (as explained below).

Some testers may have memory size restrictions for a single SVF file. The SVF limit file option enables you to limit the size of each SVF file by either file size or vectors.

The generated SVF files append an index to the file name indicating the sequence of files. The format is:

```
<SVF_filename>_XXXXX.svf
```

where XXXXX is the index of the SVF file. The first SVF file begins with <SVF\_filename>\_00000.svf and increments by 1 until file generation is complete.

**Maximum file size:** Max file size limit for the SVF file; use this option to limit your SVF file size based on number of kB.

**Maximum number of vectors:** Max vector limit for the SVF file; use this option to limit the size of your SVF based on number of vectors.

For more information on DAT files, refer to the Data File Generator (DatGen) section of the *DirectC User's Guide*.

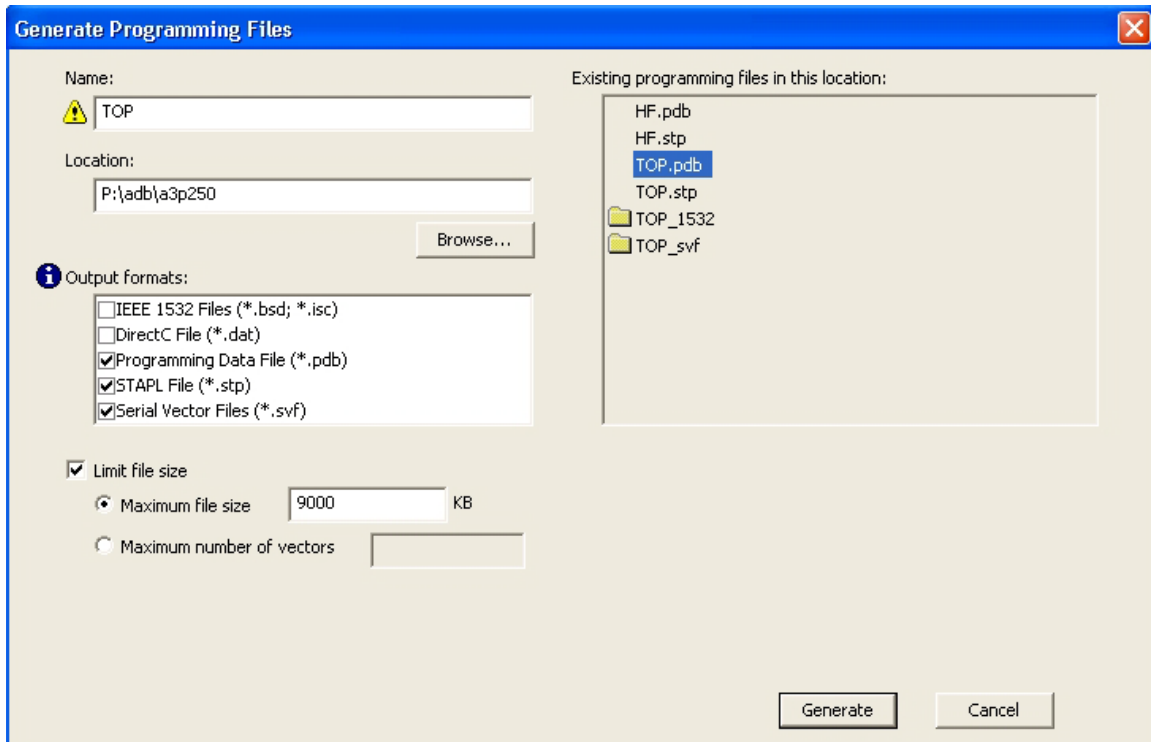

Figure 98 · Generate Programming Files Dialog Box (Flashpoint)

## Generate a Programming File for SmartFusion

You can configure and generate a new PDB file from FlashPoint.

If you are using Single Mode, click **Create** to add a new PDB, or click **Modify** to make changes to a loaded PDB.

In Chain Mode, if you have not already done so, [construct a chain](#) and click **Create PDB** to create a new PDB for programming, or click **Modify PDB** to make changes to a loaded PDB.

FlashPoint enables you to specify your [security settings](#) and silicon features when you generate your programming file in SmartFusion. You can specify your [FPGA Array](#), [FlashROM](#), and [Embedded Flash Memory](#) by importing FDB, UFC and EFC files, respectively (as shown in the figure below). If you have imported a FlashROM and Embedded Flash Memory file you can click **Modify** to configure these feature before saving your PDB file.

Click [Specify I/O States During Programming](#) to set custom I/O states.

**Note:** NOTE: You must import an FDB to populate Port Name and Macro Cell columns.

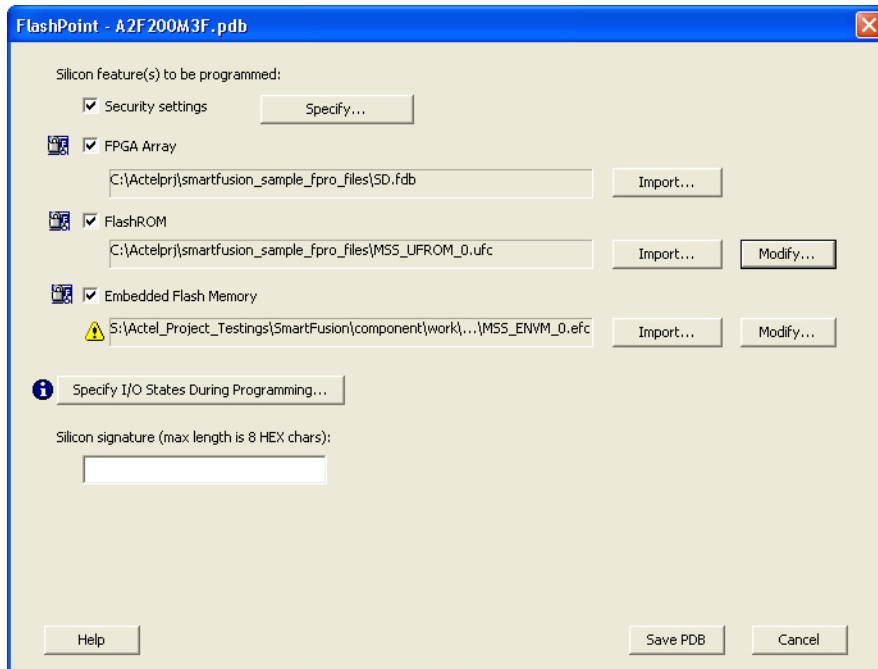

Figure 99 · FlashPoint Programming Settings for SmartFusion

## Generate a Programming File for CoreMP7/Cortex-M1 Device Support

FlashPoint enables you to program FPGA Array and FlashROM features for CoreMP7/Cortex-M1 devices. You can program these features separately using different programming files or you can combine them into one programming file. Each feature is listed as a silicon feature in the GUI. You can generate a programming file with one, two, or all of the silicon features from the **Programming File Generator** first page. For CoreMP7/Cortex-M1 device support, you cannot select your own security settings. The generated programming file always has the encrypted FPGA Array content. The programming file generation is the same as the ProASIC3 family devices.

### *To generate a programming file:*

1. Select the Silicon feature(s) you want to program.

[FPGA Array](#)

[FlashROM](#)

2. Click **Next** or **Finished** depending on the silicon features you selected.

If you click **Next**, follow the instructions in the appropriate dialog box. If you click **Finish**, the **Generate Programming Files** dialog box appears. Use this dialog box to specify the programming file name, location, and output format ([STAPL file](#), [SVF file](#), [PDB file](#), [DirectC DAT file](#), [1532 file](#)).

For more information on DAT files, refer to the Data File Generator (DatGen) section of the *DirectC User's Guide*.

## CoreMP7/Cortex-M1 Device Security

CoreMP7/Cortex-M1 devices are shipped with the following security enabled:

- FPGA Array enabled for AES encrypted programming and verification.
- FlashROM enabled for plain text read and write.

You cannot select your own security settings. The generated programming file includes the encrypted FPGA Array content.

## Programming FlashROM and FPGA Array

For CoreMP7/Cortex-M1 device support, the programming generation for [FlashROM](#) and [FPGA Array](#) is the same as the programming generation for ProASIC3 and ProASIC family devices.

## Generate a Programming File for AFS Device Support - Designer Only

FlashPoint enables you to program Security Settings, FPGA Array, Embedded Flash Memory Blocks, and FlashROM features for AFS device support. You can program these features separately using different programming files or you can combine them into one programming file. Each feature is listed as a silicon feature in the GUI. You can generate a programming file with one, two, or all of the silicon features from the **Programming File Generator** first page.

### AFS Programming

In addition to FPGA Array, FlashROM and security setting, the Fusion devices provide Embedded Flash Memory Blocks (FB) for both Analog configuration initialization and regular memory storage. Depending on the targeted AFS device, you may have one, two, or four FBs available to you. FlashPoint enables you to initialize the FB Instance(s), as described in the Embedded Flash Memory help.

#### **To generate a programming file:**

1. Select the **Silicon feature(s)** you want to program.

[Security Settings](#)

[FPGA Array](#)

[FlashROM](#)

[Embedded Flash Memory Block](#)

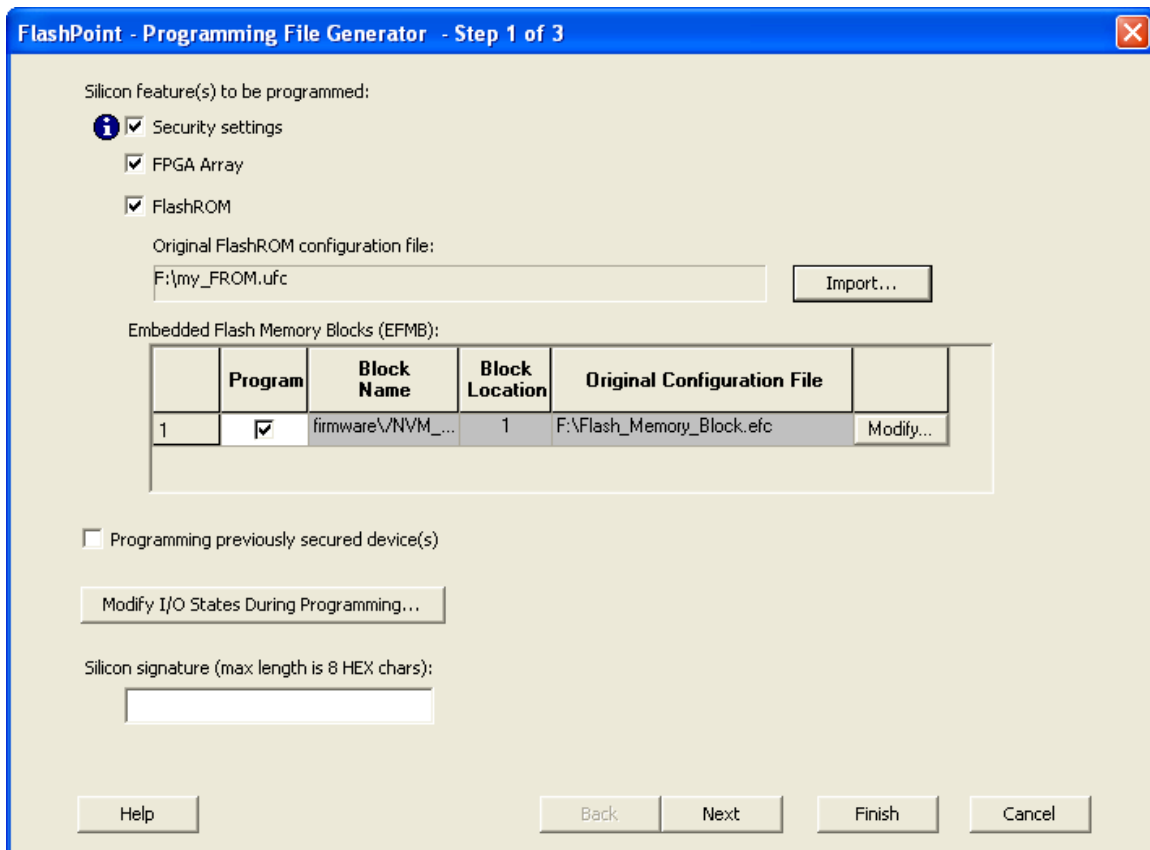

Figure 100 · FlashPoint- Programming File Generator for AFS

**Note:** Note: Check the check box in the Program column to enable block modification.

2. Check the **Programming previously secured devices(s)** box if you want to program previously secured devices.
3. Enter the **Silicon signature**.
4. Depending upon the Silicon features you selected, click **Finish** or **Next**.

If you click **Next**, follow the instructions in the appropriate dialog box. If you click **Finish**, the **Generate Programming Files** dialog box appears. Use this dialog box to specify the programming file name, location, and output format ([STAPL file](#), [SVF file](#), [PDB file](#), [DirectC DAT file](#), [1532 file](#)).

For more information on DAT files, refer to the Data File Generator (DatGen) section of the *DirectC User's Guide*.

## Programming Security Settings, FlashROM, and FPGA Array

For AFS device support, the programming generation for [Security Settings](#), [FlashROM](#) and [FPGA Array](#) is the same as the programming generation for ProASIC3 family devices.

## Generate a Programming File for Serialization Support in In House Programming (IHP)

FlashPoint allows you to program security settings, FPGA Array, and FlashROM features for IGLOO, ProASIC3, SmartFusion, Fusion, and ProASIC family devices. You can program these features separately using different programming files or you can combine them into one programming file. Each feature is listed as a silicon feature in the GUI.

### SVF Serialization Support in IHP

In addition to FPGA Array, FlashROM, and security setting, FlashPoint supports generating SVF files with serialization support in IHP.

#### **To generate SVF with serialization support:**

1. Select the **Silicon feature(s)** you want to program.
  - [Security settings](#)
  - [FPGA Array](#)
  - [FlashROM](#)
  - [Programming Embedded Flash Memory Block](#)
2. Import the UFC file which contains serialization data to FlashROM. Click **Next**.
3. Type in the number of devices to program (as shown in the figure below).

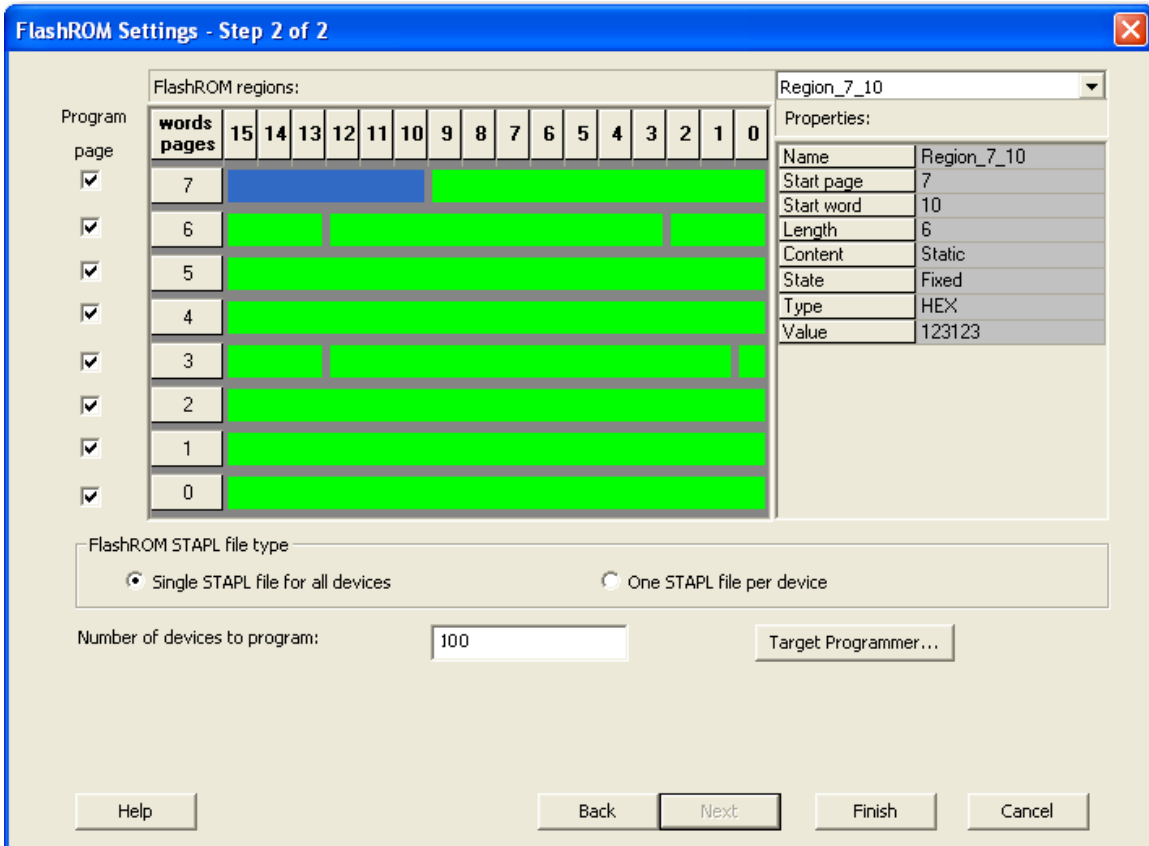

Figure 101 · Type Number of Devices

4. Click **Target Programmer** and select **Actel IHP**.

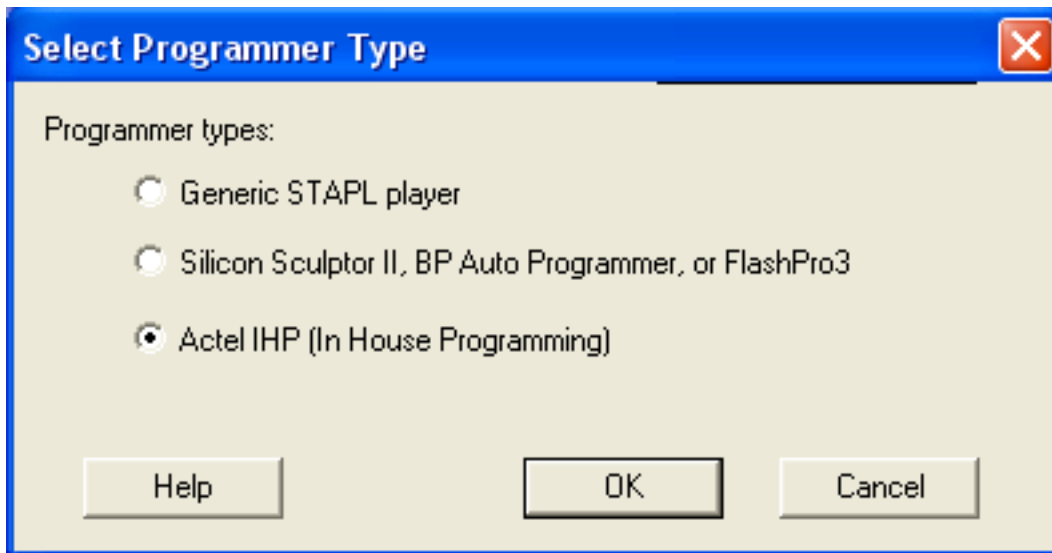
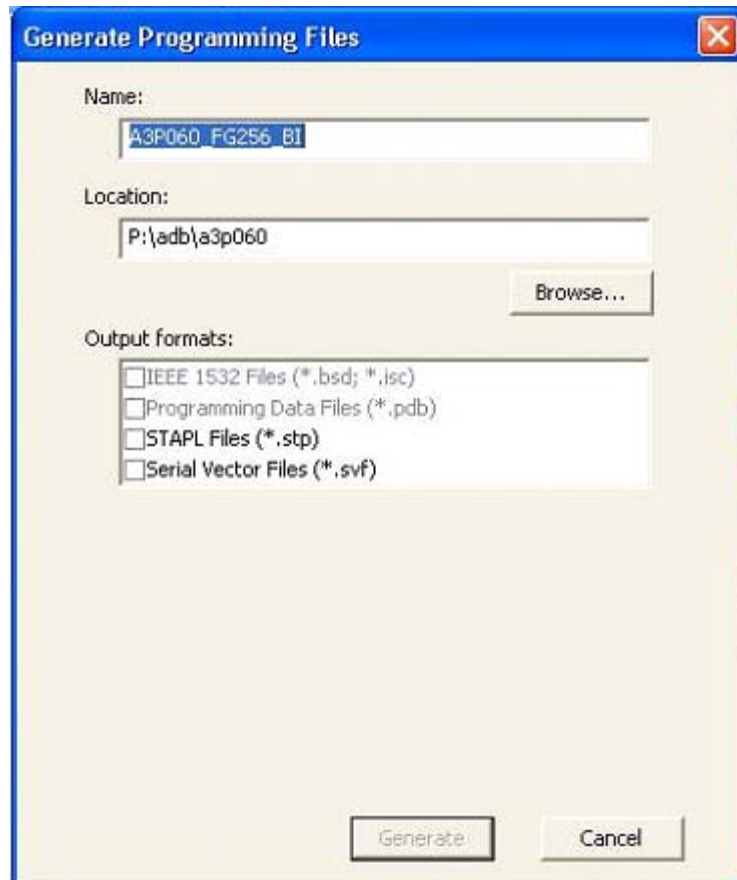

Figure 102 · Select Actel IHP



5. Click **OK**. The Generate Programming Files window appears (as shown in the figure below). Select **Serial Vector Files (\*.svf)**.



Select Serial Vector Files

6. Click **Generate**. An Actel-specific SVF file will be generated with a corresponding serialization data file.

**Note:** Note: Generated SVF files will only work with IHP.

## Creating a Programming Database (PDB) File in Designer

The programming database (PDB) file supports IGLOO, ProASIC3, SmartFusion and Fusion devices only. This allows reconfiguration of the security settings, FlashROM, FPGA Array, and Embedded Flash Memory Blocks. You create the file in Designer using FlashPoint and you modify the file in FlashPro.

You must create programming files for SmartFusion in FlashPro; see the [Generate a Programming File for SmartFusion](#) topic for more information.

1. From the Designer main window, click the **Programming File** button. This brings up FlashPoint (see figure below).

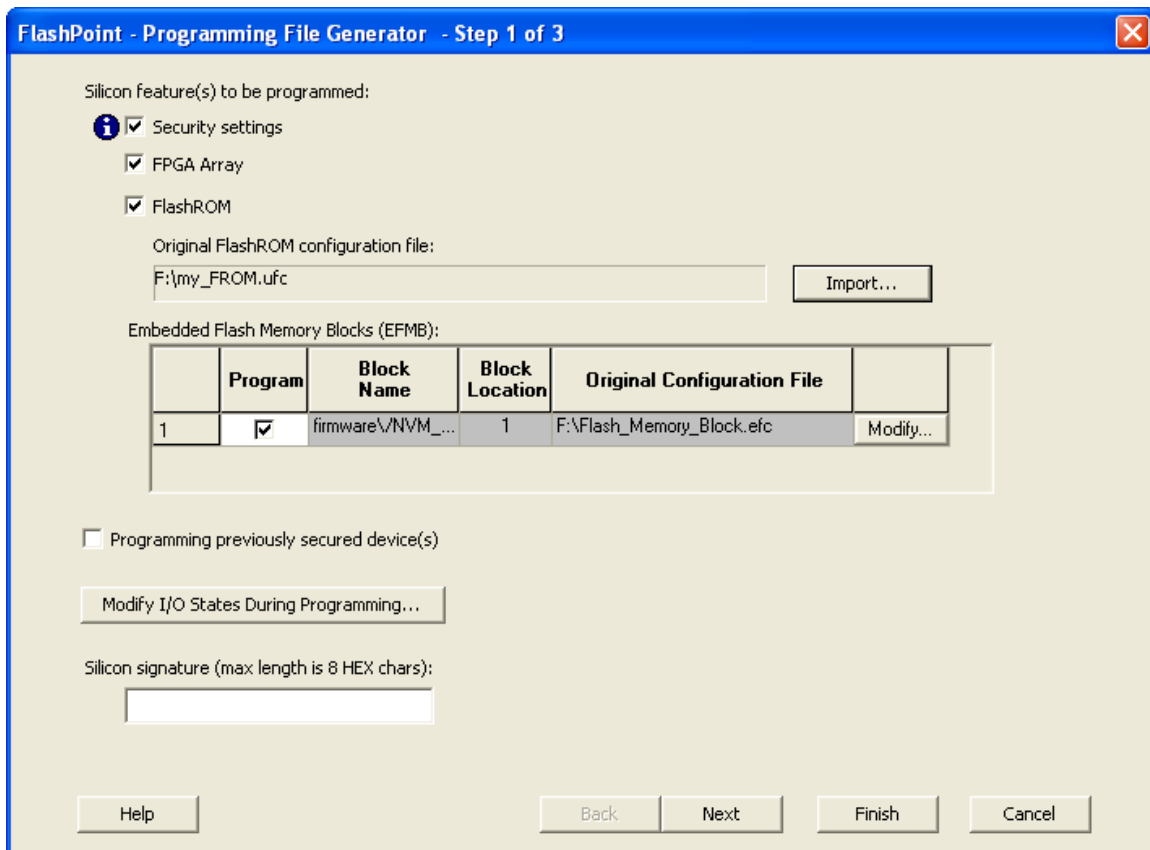

Figure 103 · FlashPoint Programming File Generator - PDB File

2. Select the **silicon feature(s) to be programmed**: [Security Settings](#), [FPGA array](#), [FlashROM](#), and [Embedded Flash Memory Block](#). If you are programming a previously secured device, check the **Programming previously secured device(s)** and enter the silicon signature.
3. Click **Finish** to create the PDB file.

### See Also

[Configuring security and FlashROM settings in FlashPro](#)

[Configuring security settings in FlashPro](#)

[Configuring FPGA array settings](#)

[Configuring FlashROM settings in FlashPro](#)

[Configuring Embedded Flash Memory Block settings in FlashPro](#)

## Programming Embedded Flash Memory Block

For more information about the Embedded Flash Memory Block, see the [Flash Memory System Builder](#) online help.

**To program the Embedded Flash Memory Block:**

1. Check the **Program** box to enable Embedded Flash Memory Block modification.
2. Click the **Modify** button to import Embedded Flash Memory Block configuration and memory content.

The **Modify Embedded Flash Memory Block** dialog box appears.

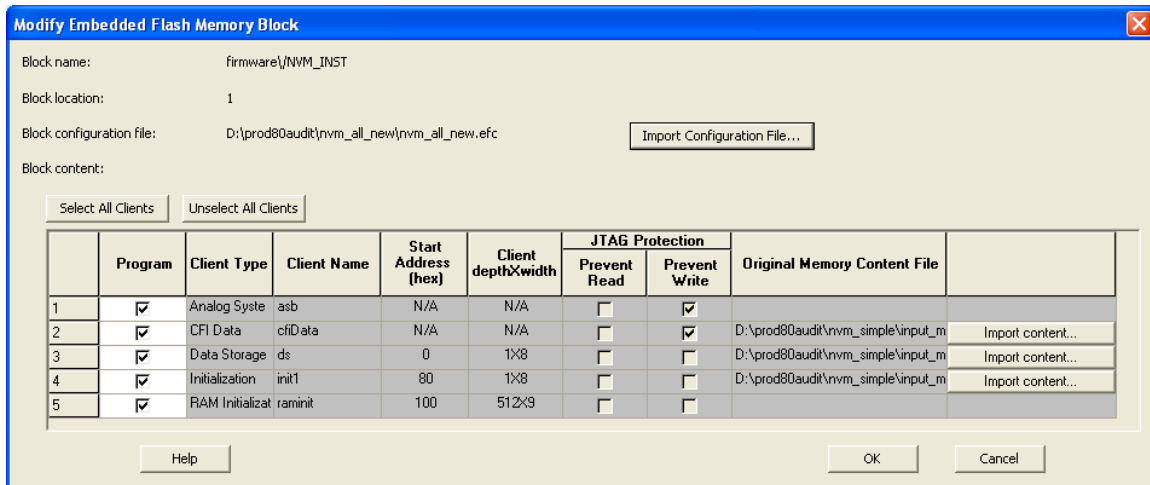

Figure 104 · Modify Embedded Flash Memory Block Content Dialog Box

3. Click the **Import Configuration File** button (if available) to import the Embedded Flash Memory Block configuration and memory content from the EFC file. This will populate the client table below. All clients that belong to this block will be selected by default.
4. Click the **Import content** button if you want to change the client memory content.
5. Click **OK**.

**Note:** Note: FlashPoint audits original configuration and memory content files and warns you if the files cannot be located or if they have been updated.

## Programming the FlashROM

You can program selected memory pages and specify the region values of the FlashROM.

- **Single STAPL file for all devices:** generates one programming file with all the generated increment values or with values in the custom serialization file.
  - **One STAPL file per device:** generates one programming file for each generated increment value or for each value in the custom serialization file.
1. Select your target **Programmer type**.
    - Select Generic STAPL Player when generating STAPL files for generic STAPL players.
    - Select Silicon Sculptor II, BP Auto Programmer, or FlashPro4/3x/3 when generating programming files for those programmers.

- Select Actel IHP (In House Programming) when generating STAPL or SVF files for Actel IHP.

2. Click **OK**.  
FlashPoint generates your programming file.

**Note:** Note: You cannot change the FlashROM region configuration from FlashPoint. You can only change the configuration from the FlashROM core generator.

For more information, click the Help button in FlashROM.

#### To program FlashROM:

1. Select **FlashROM** from the **Generate Programming File** page.
2. Enter the location of the FlashROM configuration file. The **FlashROM Settings** page appears (see figure below).

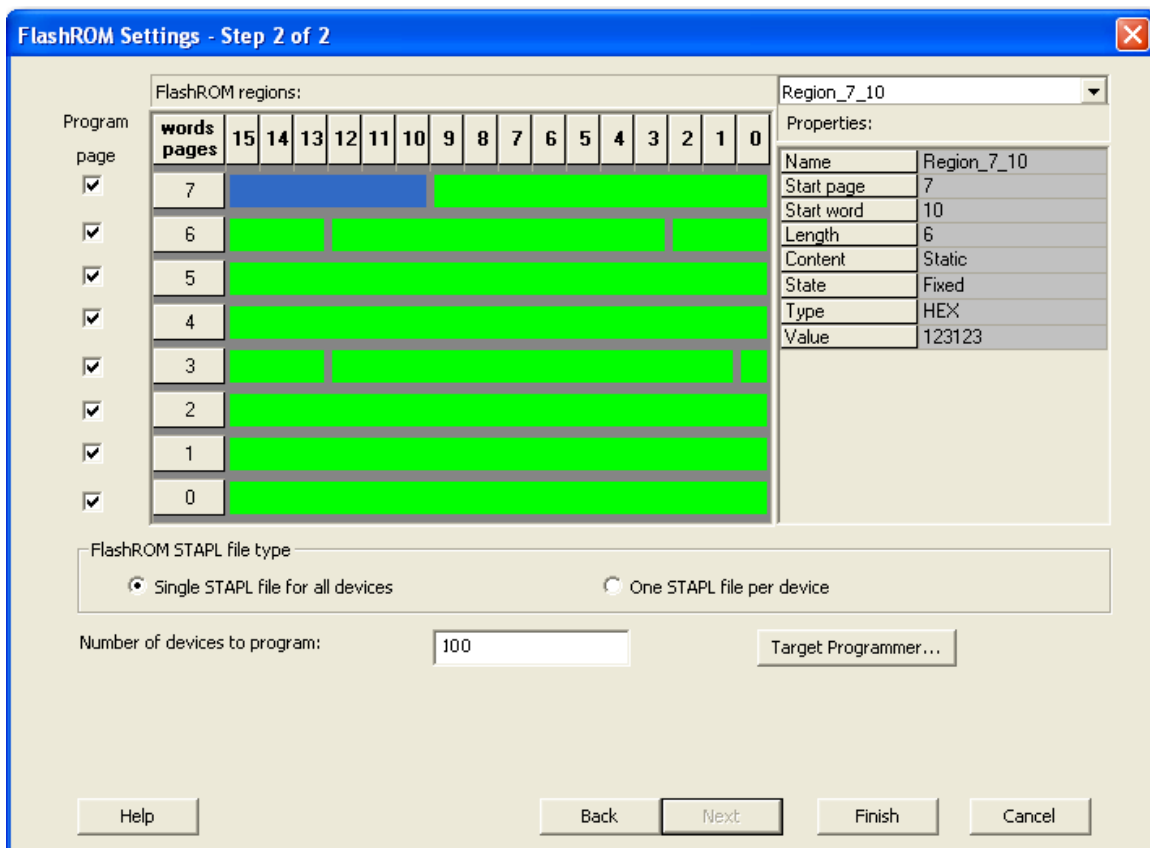

Figure 105 · FlashROM Settings

3. Select the FlashROM memory page that you want to program.
4. Enter the data value for the configured regions.
5. If you selected the region with a **Read From File**, specify the file location.

- If you selected the **Auto Increment** region, specify the **Start** and **Max** values.

Enter the number of devices you want to program.

Select your target Programmer Type.

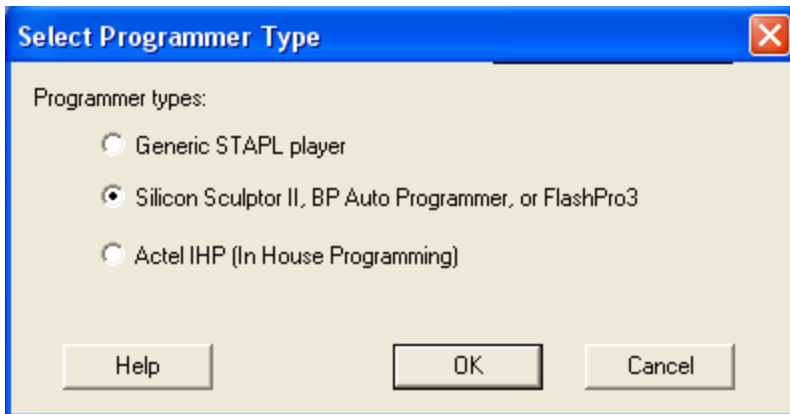

Select Programmer

- Click **Finish**.

FlashPoint generates your programming file.

**Note:** Note: You cannot change the FlashROM region configuration from FlashPoint. You can only change the configuration from the FlashROM core generator.

## Silicon Signature

With Libero IDE tools, you can use the silicon signature to identify and track Actel designs and devices. When you generate a programming file, you can specify a unique silicon signature to program into the device. This signature is stored in the design database and in the programming file, and programmed into the device during programming.

The silicon signature is accessible through the USERCODE JTAG instruction.

**Note:** Note: If you set the security level to high, medium, or custom, you must program the silicon signature along with the Security Setting. If you have already programmed the Security Setting into the target device, you cannot reprogram the silicon signature without reprogramming the Security Setting.

**Note:** The previously programmed silicon signature will be erased if:

- You have already programmed the silicon signature and
- You are programming the security settings, but you do not have an entry in the silicon signature field

## Programming Security Settings

FlashPoint allows you to set a security level of high, medium, or none (SmartFusion uses radio buttons and the option Clear Security instead of None).

**To program Security Settings on the device:**

1. If you choose to program Security Settings on the device from the **Generate Programming File** page, the wizard takes you to the **Security Settings** page.

Your Security Settings page depends on your family.

2. Set the security level for FPGA and FlashROM (see the table below for a description of the security levels).

Table 7 · FPGA and FlashROM Security Levels

Security Level	Security Option	Description
High	Protect with a 128-bit Advanced Encryption Standard (AES) key and a Pass Key	<p>Access to the device is protected by an AES Key and the Pass Key.</p> <p>The Write and Verify operations of the FPGA Array use a 128-bit AES encrypted bitstream.</p> <p>From the JTAG interface, the Write and Verify operations of the FlashROM use a 128-bit AES encrypted bitstream. Read back of the FlashROM content via the JTAG interface is protected by the Pass Key.</p> <p>Read back of the FlashROM content is allowed from the FPGA Array.</p>
Medium	Protect with Pass Key	<p>The Write and Verify operations of the FPGA Array require a Pass Key.</p> <p>From the JTAG interface, the Read and Write operations on the FlashROM content require a Pass Key. You can Verify the FlashROM content via the JTAG interface without a Pass Key.</p> <p>Read back of the FlashROM content is allowed from the FPGA Array.</p>
None	No security	<p>The Write and Verify operations of the FPGA Array do not require keys.</p> <p>The Read, Write, and Verify operations of the FlashROM content also do not require keys.</p> <p>This option is available for SmartFusion; to choose it, de-select the Security Settings checkbox.</p>

3. Enter the **Pass Key** and/ or the **AES Key** as appropriate. You can generate a random key by clicking the **Generate random key** button.

The **Pass Key** protects all the Security Settings for the FPGA Array and/or FlashROM.

The **AES Key** decrypts FPGA Array and/or FlashROM programming file content. Use the AES Key if you intend to program the device at an unsecured site or if you plan to update the design at a remote site in the future.

You can also customize the security levels by clicking the **Custom Level** button. For more information, see the [Custom Security Levels](#) section.

## Custom Security Levels

For advanced use, you can customize your security levels.

### To set custom security levels:

1. Click the **Custom Level** button in the **Security Settings** page. The **Custom Security Level** dialog box appears.
2. Select the **FPGA Array Security** and the **FlashROM Security** levels. For SmartFusion and Fusion devices, you can also choose the Embedded Flash Memory Block level of security. The FPGA Array and the FlashROM can have different Security Settings. See the tables below for a description of the custom security option levels for FPGA Array and FlashROM.

Table 8 · FPGA Array

Security Option						Description
Lock for both writing and verifying						Allows writing/erasing and verification of the FPGA Array via the JTAG interface only with a valid Pass Key.
Device Feature	Set Security	Encrypt	Security Settings			
FPGA Array	<input checked="" type="checkbox"/>	<input type="checkbox"/>	Read	Verify	Write	
Lock for writing						Allows the writing/erasing of the FPGA Array only with a valid Pass Key. Verification is allowed without a valid Pass Key.
Device Feature	Set Security	Encrypt	Security Settings			
FPGA Array	<input checked="" type="checkbox"/>	<input type="checkbox"/>	Read	Verify	Write	
Use the AES Key for both writing and verifying						Allows the writing/erasing and verification of the FPGA Array only with a valid AES Key via the JTAG interface. This configures the device to accept an encrypted bitstream for reprogramming and verification
Device Feature	Set Security	Encrypt	Security Settings			
FPGA Array	<input checked="" type="checkbox"/>	<input checked="" type="checkbox"/>	Read	Verify	Write	

Security Option	Description															
	of the FPGA Array. Use this option if you intend to complete final programming at an unsecured site or if you plan to update the design at a remote site in the future. Accessing the device security settings requires a valid Pass Key.															
<p>Allow write and verify</p> <table border="1"> <thead> <tr> <th rowspan="2">Device Feature</th> <th rowspan="2">Set Security</th> <th rowspan="2">Encrypt</th> <th colspan="3">Security Settings</th> </tr> <tr> <th>Read</th> <th>Verify</th> <th>Write</th> </tr> </thead> <tbody> <tr> <td>FPGA Array</td> <td><input type="checkbox"/></td> <td><input type="checkbox"/></td> <td></td> <td></td> <td></td> </tr> </tbody> </table>	Device Feature	Set Security	Encrypt	Security Settings			Read	Verify	Write	FPGA Array	<input type="checkbox"/>	<input type="checkbox"/>				Allows writing/erasing and verification of the FPGA Array with plain text bitstream and without requiring a Pass Key or an AES Key. Use this option when you develop your product in-house.
Device Feature				Set Security	Encrypt	Security Settings										
	Read	Verify	Write													
FPGA Array	<input type="checkbox"/>	<input type="checkbox"/>														

**Note:** Note: The ProASIC3 family FPGA Array is always read protected regardless of the Pass Key or the AES Key protection.

Table 9 · FlashROM

Security Option	Description															
<p>Lock for both reading and writing</p> <table border="1"> <thead> <tr> <th rowspan="2">Device Feature</th> <th rowspan="2">Set Security</th> <th rowspan="2">Encrypt</th> <th colspan="3">Security Settings</th> </tr> <tr> <th>Read</th> <th>Verify</th> <th>Write</th> </tr> </thead> <tbody> <tr> <td>FlashROM</td> <td><input checked="" type="checkbox"/></td> <td><input type="checkbox"/></td> <td></td> <td></td> <td></td> </tr> </tbody> </table>	Device Feature	Set Security	Encrypt	Security Settings			Read	Verify	Write	FlashROM	<input checked="" type="checkbox"/>	<input type="checkbox"/>				Allows the writing/erasing and reading of the FlashROM via the JTAG interface only with a valid Pass Key. Verification is allowed without a valid Pass Key.
Device Feature				Set Security	Encrypt	Security Settings										
	Read	Verify	Write													
FlashROM	<input checked="" type="checkbox"/>	<input type="checkbox"/>														
<p>Lock for writing</p> <table border="1"> <thead> <tr> <th rowspan="2">Device Feature</th> <th rowspan="2">Set Security</th> <th rowspan="2">Encrypt</th> <th colspan="3">Security Settings</th> </tr> <tr> <th>Read</th> <th>Verify</th> <th>Write</th> </tr> </thead> <tbody> <tr> <td>FlashROM</td> <td><input checked="" type="checkbox"/></td> <td><input type="checkbox"/></td> <td></td> <td></td> <td></td> </tr> </tbody> </table>	Device Feature	Set Security	Encrypt	Security Settings			Read	Verify	Write	FlashROM	<input checked="" type="checkbox"/>	<input type="checkbox"/>				Allows the writing/erasing of the FlashROM via the JTAG interface only with a valid Pass Key. Reading and verification is allowed without a valid Pass Key.
Device Feature				Set Security	Encrypt	Security Settings										
	Read	Verify	Write													
FlashROM	<input checked="" type="checkbox"/>	<input type="checkbox"/>														
<p>Use the AES Key for both writing and verifying</p>	Allows the writing/erasing and verification of the FlashROM via the JTAG interface only with															



Security Option						Description															
<table border="1"> <thead> <tr> <th rowspan="2">Device Feature</th> <th rowspan="2">Set Security</th> <th rowspan="2">Encrypt</th> <th colspan="3">Security Settings</th> </tr> <tr> <th>Read</th> <th>Verify</th> <th>Write</th> </tr> </thead> <tbody> <tr> <td>FlashROM</td> <td><input checked="" type="checkbox"/></td> <td><input checked="" type="checkbox"/></td> <td></td> <td></td> <td></td> </tr> </tbody> </table>						Device Feature	Set Security	Encrypt	Security Settings			Read	Verify	Write	FlashROM	<input checked="" type="checkbox"/>	<input checked="" type="checkbox"/>				<p>a valid AES Key. This configures the device to accept an encrypted bitstream for reprogramming and verification of the FlashROM. Use this option if you complete final programming at an unsecured site or if you plan to update the design at a remote site in the future.</p> <p>Note: The bitstream that is read back from the FlashROM is always unencrypted (plain text).</p>
Device Feature	Set Security	Encrypt	Security Settings																		
			Read	Verify	Write																
FlashROM	<input checked="" type="checkbox"/>	<input checked="" type="checkbox"/>																			
<p>Allow reading, writing, and verifying</p> <table border="1"> <thead> <tr> <th rowspan="2">Device Feature</th> <th rowspan="2">Set Security</th> <th rowspan="2">Encrypt</th> <th colspan="3">Security Settings</th> </tr> <tr> <th>Read</th> <th>Verify</th> <th>Write</th> </tr> </thead> <tbody> <tr> <td>FlashROM</td> <td><input type="checkbox"/></td> <td><input type="checkbox"/></td> <td></td> <td></td> <td></td> </tr> </tbody> </table>						Device Feature	Set Security	Encrypt	Security Settings			Read	Verify	Write	FlashROM	<input type="checkbox"/>	<input type="checkbox"/>				<p>Allows writing/erasing, reading and verification of the FlashROM content with a plain text bitstream and without requiring a valid Pass Key or an AES Key.</p>
Device Feature	Set Security	Encrypt	Security Settings																		
			Read	Verify	Write																
FlashROM	<input type="checkbox"/>	<input type="checkbox"/>																			

Note: The FPGA Array can always read the FlashROM content regardless of these Security Settings.

Table 10 · Embedded Flash Memory Block

Security Option						Description															
<p>Lock for reading, verifying, and writing</p> <table border="1"> <thead> <tr> <th rowspan="2">Device Feature</th> <th rowspan="2">Set Security</th> <th rowspan="2">Encrypt</th> <th colspan="3">Security Settings</th> </tr> <tr> <th>Read</th> <th>Verify</th> <th>Write</th> </tr> </thead> <tbody> <tr> <td>firmware\NVM_INST (# 1)</td> <td><input checked="" type="checkbox"/></td> <td><input type="checkbox"/></td> <td></td> <td></td> <td></td> </tr> </tbody> </table>						Device Feature	Set Security	Encrypt	Security Settings			Read	Verify	Write	firmware\NVM_INST (# 1)	<input checked="" type="checkbox"/>	<input type="checkbox"/>				<p>Allows the writing and reading of the Embedded Flash Memory Block via the JTAG interface only with a valid Pass Key. Verification accomplished by reading back and compare.</p>
Device Feature	Set Security	Encrypt	Security Settings																		
			Read	Verify	Write																
firmware\NVM_INST (# 1)	<input checked="" type="checkbox"/>	<input type="checkbox"/>																			
<p>Lock for writing</p> <table border="1"> <thead> <tr> <th rowspan="2">Device Feature</th> <th rowspan="2">Set Security</th> <th rowspan="2">Encrypt</th> <th colspan="3">Security Settings</th> </tr> <tr> <th>Read</th> <th>Verify</th> <th>Write</th> </tr> </thead> <tbody> <tr> <td>firmware\NVM_INST (# 1)</td> <td><input checked="" type="checkbox"/></td> <td><input type="checkbox"/></td> <td></td> <td></td> <td></td> </tr> </tbody> </table>						Device Feature	Set Security	Encrypt	Security Settings			Read	Verify	Write	firmware\NVM_INST (# 1)	<input checked="" type="checkbox"/>	<input type="checkbox"/>				<p>Allows the writing of the Embedded Flash Memory Block via the JTAG interface only with a valid Pass Key. Reading and verification is allowed without a</p>
Device Feature	Set Security	Encrypt	Security Settings																		
			Read	Verify	Write																
firmware\NVM_INST (# 1)	<input checked="" type="checkbox"/>	<input type="checkbox"/>																			

Security Option						Description														
						valid Pass Key.														
Use AES Key for writing						Allows the writing of the Embedded Flash Memory Block via the JTAG interface only with a valid AES Key. This configures the device to accept an encrypted bitstream for reprogramming of the Embedded Flash Block. Use this option if you complete final programming at an unsecured site or if you plan to update the design at a remote site in the future. The bitstream that is read back from the Embedded Flash Memory Block is always unencrypted (plain text), when a valid pass key is provided.														
<table border="1"> <thead> <tr> <th rowspan="2">Device Feature</th> <th rowspan="2">Set Security</th> <th rowspan="2">Encrypt</th> <th colspan="3">Security Settings</th> </tr> <tr> <th>Read</th> <th>Verify</th> <th>Write</th> </tr> </thead> <tbody> <tr> <td>firmwareVNVM_INST (# 1)</td> <td><input checked="" type="checkbox"/></td> <td><input checked="" type="checkbox"/></td> <td></td> <td></td> <td></td> </tr> </tbody> </table>							Device Feature	Set Security	Encrypt	Security Settings			Read	Verify	Write	firmwareVNVM_INST (# 1)	<input checked="" type="checkbox"/>	<input checked="" type="checkbox"/>		
Device Feature	Set Security	Encrypt	Security Settings																	
			Read	Verify	Write															
firmwareVNVM_INST (# 1)	<input checked="" type="checkbox"/>	<input checked="" type="checkbox"/>																		
Allow reading, writing, and verifying						Allows writing, reading and verification of the Embedded Flash Memory Block content with a plain text bitstream and without requiring a valid Pass Key or an AES Key.														
<table border="1"> <thead> <tr> <th rowspan="2">Device Feature</th> <th rowspan="2">Set Security</th> <th rowspan="2">Encrypt</th> <th colspan="3">Security Settings</th> </tr> <tr> <th>Read</th> <th>Verify</th> <th>Write</th> </tr> </thead> <tbody> <tr> <td>firmwareVNVM_INST (# 1)</td> <td><input type="checkbox"/></td> <td><input type="checkbox"/></td> <td></td> <td></td> <td></td> </tr> </tbody> </table>							Device Feature	Set Security	Encrypt	Security Settings			Read	Verify	Write	firmwareVNVM_INST (# 1)	<input type="checkbox"/>	<input type="checkbox"/>		
Device Feature	Set Security	Encrypt	Security Settings																	
			Read	Verify	Write															
firmwareVNVM_INST (# 1)	<input type="checkbox"/>	<input type="checkbox"/>																		

- To make the Security Settings permanent, select **Permanently lock the security settings** check box. This option prevents any future modifications of the Security Setting of the device. A Pass Key is not required if you use this option.

**Note:** When you make the Security Settings permanent, you can never reprogram the [Silicon Signature](#). If you Lock the write operation for the FPGA Array or the FlashROM, you can never reprogram the FPGA Array or the FlashROM, respectively. If you use an AES key, this key cannot be changed once you permanently lock the device.

- (SmartFusion Only) Enable M3 Debugger option enables access to the M3 debugger even if security is enforced. Select the **Enable M3 debugger** checkbox if you want to access the M3 debugger after programming.

5. To use the Permanent FlashLock™ feature, select **Lock for both writing and verifying** for FPGA Array and **Lock for both reading and writing** for FlashROM and select the **Permanently lock the security settings** checkbox as shown in the figure below. This will make your device one-time-programmable.

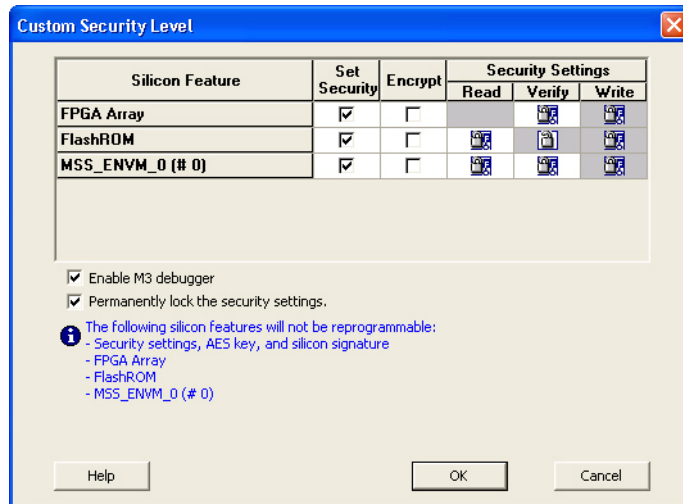

Custom Security Level

6. Click the **OK** button. The **Security Settings** page appears with the **Custom security settings** information as shown in the figure below.

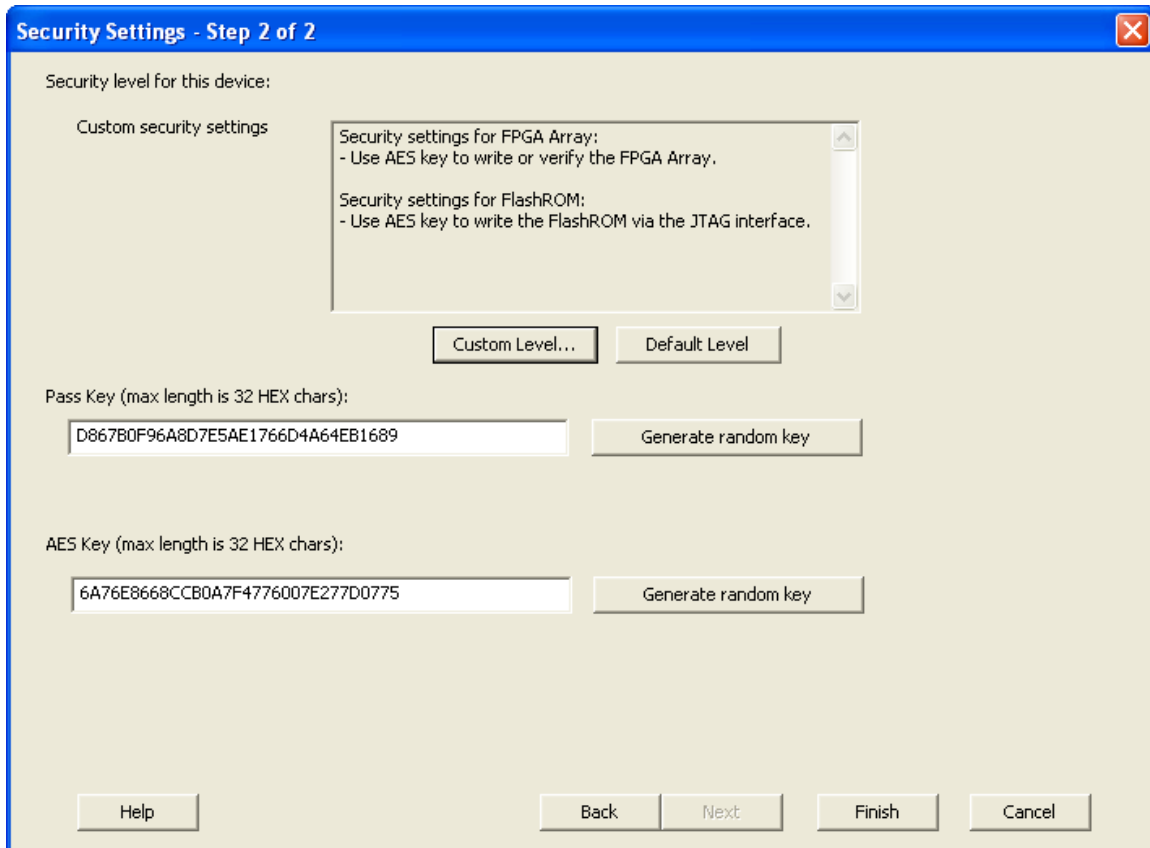

Figure 106 · Security Settings

## Reprogramming a Secured Device

You must know the previous Security Settings of the device before you can reprogram a device with Security Settings.

### **To program a secured device:**

1. In the Generate Programming File window, click the **Programming previously secured devices(s)** check box (see figure below).

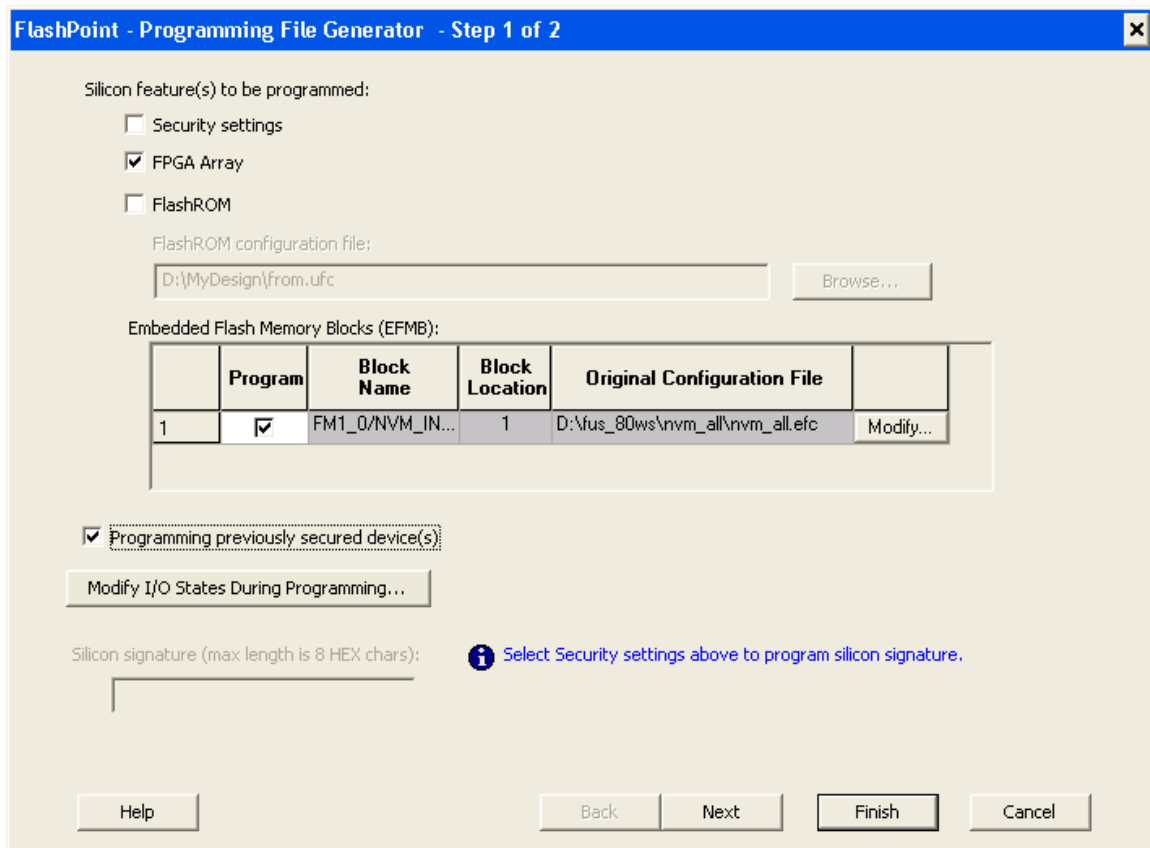

Figure 107 · Generate Programming File

2. Specify the previously programmed security setting for the FlashROM and/or the FPGA Array. To generate a programming file for encrypted programming please ensure that the Security settings checkbox is unchecked.
3. If you programmed the device with a custom security level, click the **Custom Level** button to open the Custom security dialog box, and select the **Security Settings for the FPGA Array** or the FlashROM that you programmed (see figure below).

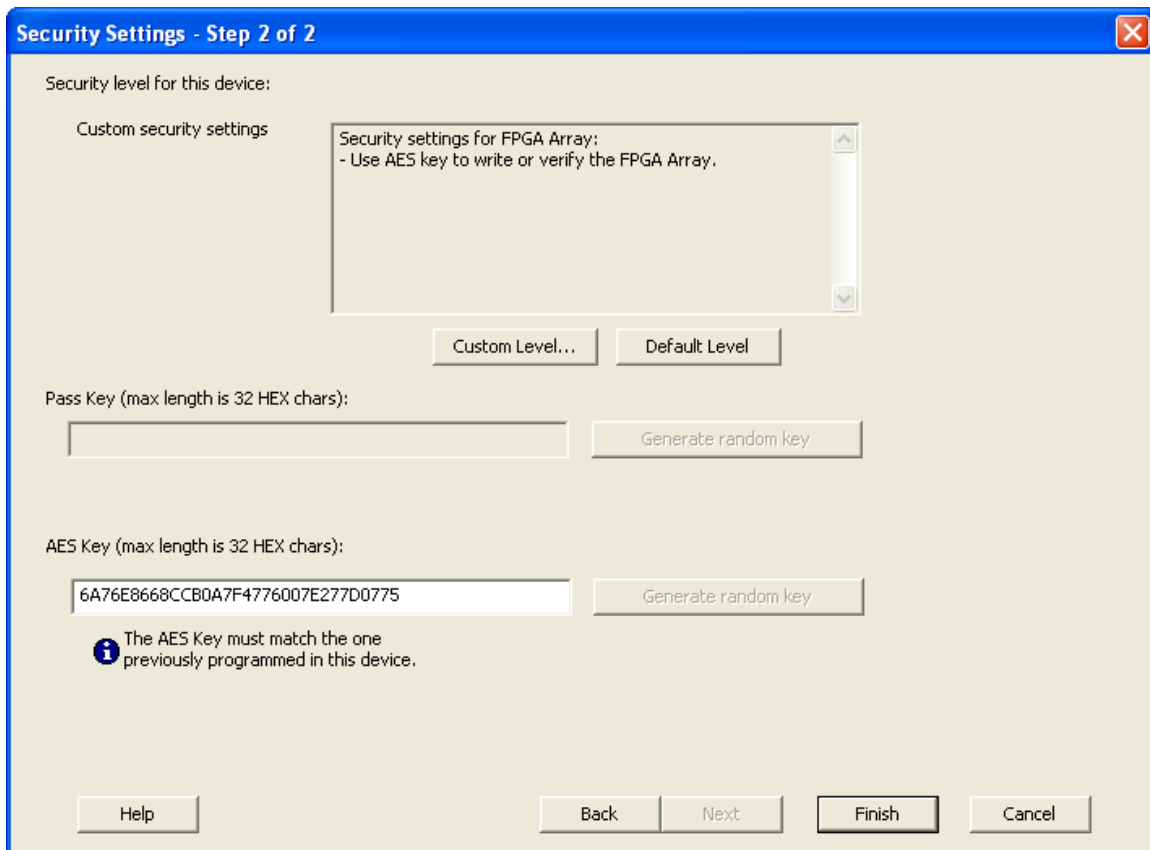

Figure 108 · Security Settings

4. Enter the previously programmed Pass Key and/or the AES Key.
5. Click **Finish**.

**Note:** Note: Enter the AES Key only if you want to perform encrypted programming.

## Programming a Secured SmartFusion Device

After you create a PDB you may wish to export a programming file for a secured device. To do so:

1. Create a PDB file (as explained above) with security set to **High** or **Medium**. Save the PDB file.
2. From the **File** menu, choose **Export Single Programming File**. The [Export Programming Files](#) dialog box appears.
3. Click the **Export programming file(s) for currently secured device** checkbox. This exports programming files for devices that already have security settings programmed.
4. Choose your outputs and enter your output file **Name** and **Location**.
5. Click **Export** to create the file(s). Your updated secured programming files are in the directory you specified.

## Custom Serialization Data for FlashROM Region

FlashPoint enables you to specify a custom serialization file as a source to provide content for programming into a Read from file FlashROM region. You can use this feature for serializing the target device with a custom serialization scheme.

### To specify a FlashROM region:

1. From the Properties section in the FlashROM Settings page, select the file name of the custom serialization file (see figure below). For more information on custom serialization files, see [Custom Serialization Data File Format](#).

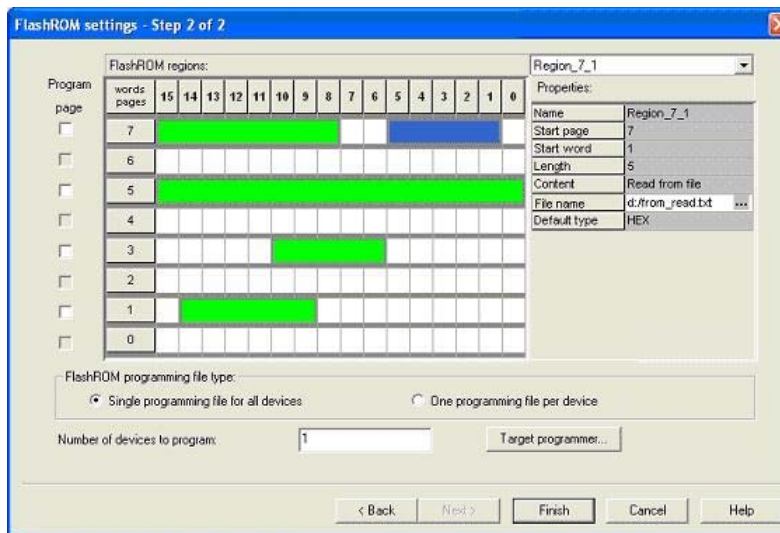

Figure 109 · FlashROM Settings

2. Select the FlashROM programming file type you want to generate from the two options below:
  - Single programming file for all devices option: generates one programming file with all the values in the custom serialization file.
  - One programming file per device: generates one programming file for each value in the custom serialization file.
3. Enter the number of devices you want to program.
4. Click the **Target Programmer** button.
5. Select your target Programmer type.
6. Click **OK**.

## Custom Serialization Data File Format

FlashPoint supports custom serialization data files that specify the data in binary, HEX, decimal, or ASCII text. The custom serialization data files may contain multiple data with the Line Feed (LF) character as the delimiter. You can create a file by entering serialization data into any type of text editor. Depending on the serialization data format (hex,

ASCII, binary, decimal), input the serialization data according to the size of the region you specified in the FlashROM settings page.

## Semantics

Each custom serialization file has only one type of data format (binary, decimal, Hex or ASCII text). For example, if a file contains two different data formats (i.e. binary and decimal) it is considered an invalid file.

The length of each data file must be shorter or equal to the selected region length. If the data is shorter than the selected region length, the most significant bits shall be padded with 0's. If the specified region length is longer than the selected region length, it is considered an invalid file.

The digit / character length is as follows:

- Binary digit: 1 bit
- Decimal digit: 4 bits
- Hex digit: 4 bits
- ASCII Character: 8 bits

**Note:** Note the standard example below:

If you wanted to use, for example, device serialization for three devices with serialization data 123, 321, and 456, you would create file name from\_read.txt. Each line in from\_read.txt corresponds to the serialization data that will be programmed on each device. For example, the first line corresponds to the first device to be programmed, the second line corresponds to the second device to be programmed, and so on.

## Hex serialization data file example

The following example is a Hex serialization data file for a 40-bit region. Enter the serialization data below into file created by any text editor:

```
123AEd210
AeB1
0001242E
```

**Note:** Note: If you enter an invalid Hex digit such as 235SedF1, an error occurs. An error will also occur if you enter data that is out of range, i.e. 4300124EFE.

The following is an example of programming "AeB1" into Region\_7\_1 located on page 7, from Word 5 to Word 1 in the FlashROM settings page. See [Custom serialization data for FlashROM region](#) for more information.

	Table 15	...	...	Word 5	Word 4	Word 3	Word 2	Word 1	Word 0
Page 7	...	...	...	00	00	00	AE	B1	...

## Binary serialization data file example

The following example is a binary serialization data file for a 16-bit region:

```
1100110011010001
```



```

100110011010011
11001100110101111 (This is an error: data out of range)
1001100110110111
1001100110110112 (This is an error: invalid binary digit)

```

### Decimal serialization data file example

The following example is a decimal serialization data file for a 16-bit region:

```

65534
65535
65536 (This is an error: data out of range)
6553A (This is an error: invalid decimal digit)

```

### Text serialization data file example

The following example is a text serialization data file for a 32-bit region:

```

AESB
A )e
ASE3 23 (This is an error: data out of range)
65A~
1234
AEbF

```

## Syntax

Indentations in the syntax below indicate a wrapped line. If a line wraps and is not indented, then it should appear on one line; you may need to expand your help window to view the syntax correctly.

```

Custom serialization data file =
    <hex region data list> | <decimal region data list> |
    <binary region data list> | <ascii text data list>
Hex region data list = <hex data> <new line> { < hex data> <new line> }
Decimal region data list = <decimal data> <new line> {<decimal data><new line> }
Binary region data list = <binary data> <new line> { <binary data> <new line> }
ASCII text region data list = < ascii text data> <new line> { < ascii text data> <new
line> }
hex data = <hex digit> {<hex digit>}
decimal data = < decimal digit> {< decimal digit>}
binary data = < binary digit> {< binary digit>}
ASCII text data = <ascii character> {< ascii character >}
new line = LF
binary digit = '0'|'1'
decimal digit = '0'|'1'|'2'|'3'|'4'|'5'|'6'|'7'|'8'| '9'
hex digit = '0'|'1'|'2'|'3'|'4'|'5'|'6'|'7'|'8'|'9'|'A'|'B'|'C'|'D'| 'E'| 'F'|
'a'| 'b'| 'c'| 'd'| 'e'| 'f'
ascii character = characters from SP(0x20) to '~'(0x7E).

```

## Specifying I/O States During Programming

In Libero IDE, the I/O states can be set prior to programming, and held at the set values during programming. In Libero IDE, this feature is only available once layout is completed.

1. From the Designer GUI, click the **Modify I/O States During Programming** button. The Programming File Generator window appears.
2. Click the **Specify I/O States During Programming** button to display the Specify I/O States During Programming dialog box.
3. Sort the pins as desired by clicking any of the column headers to sort the entries by that header. Select the I/Os you wish to modify (as shown in the figure below).
4. Set the I/O Output state. You can set Basic I/O settings if you want to use the default I/O settings for your pins, or use Custom I/O settings to customize the settings for each pin. See the [Specifying I/O States During Programming - I/O States and BSR Details help topic](#) for more information on setting your I/O state and the corresponding pin values. Basic I/O state settings are:
  - 1 – I/O is set to drive out logic High
  - 0 – I/O is set to drive out logic Low
  - Last Known State: I/O is set to the last value that was driven out prior to entering the programming mode, and then held at that value during programming
  - Z - Tri-State: I/O is tristated

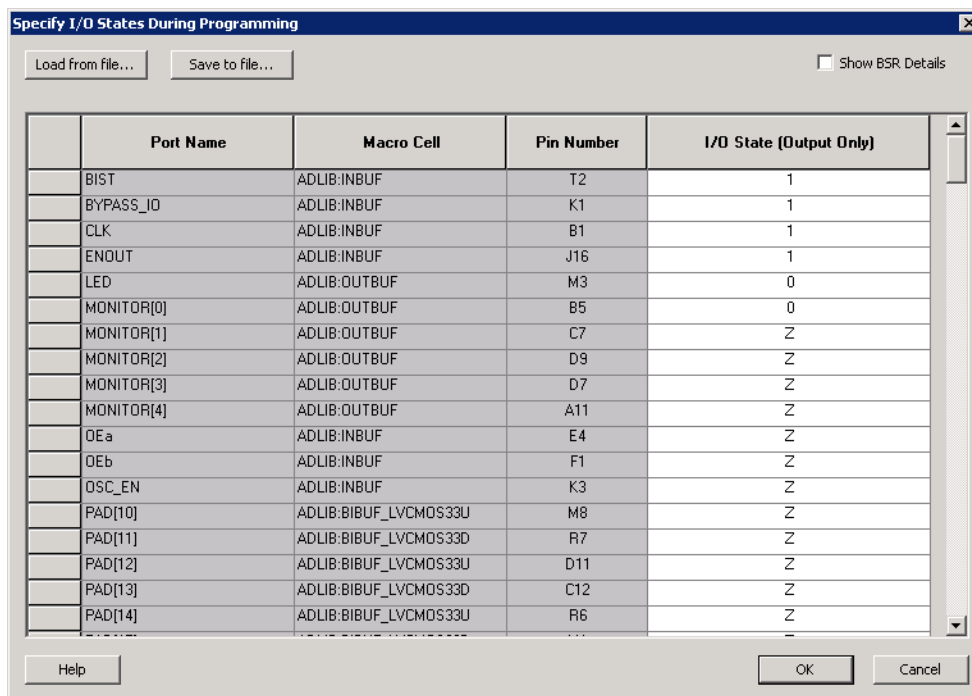

Figure 110 · I/O States During Programming Window

- Click **OK** to return to the FlashPoint – Programming File Generator window.

**Note:** NOTE: I/O States During programming are saved to the ADB and resulting programming files after completing programming file generation.

## Custom I/O Settings and Boundary Scan Registers

Each I/O in your device is comprised of an Input, Output and Output Enable Boundary Scan Register (BSR) cell.

The BSR cells enable you to define I/O states during programming and control the individual states for each Input, Output, and Output Enable register.

The [Specify I/O States During Programming dialog box](#) enables access to each of these BSR cells for control over the individual states. You can use the I/O State (Output Only) settings to set a specific output state and ignore the other values for the individual BSR elements, or you can click the [Show BSR Details checkbox](#) for control over the settings for each Input, Output Enable, and Output as you exit programming.

## Specifying I/O States During Programming - I/O States and BSR Details

The I/O States During Programming dialog box enables you to set custom I/O states prior to programming.

### I/O State (Output Only)

Sets your I/O states during programming to one of the values shown in the list below.

- 1 – I/Os are set to drive out logic High
- 0 – I/Os are set to drive out logic Low
- Last Known State: I/Os are set to the last value that was driven out prior to entering the programming mode, and then held at that value during programming
- Z - Tri-State: I/Os are tristated

When you set your I/O state, the Boundary Scan Register cells are set according to the table below. Use the Show BSR Details option to set custom states for each cell.

Table 11 · Default I/O Output Settings

Output State	Settings		
	Input	Control (Output Enable)	Output
Z (Tri-State)	1	0	0
0 (Low)	1	1	0
1 (High)	0	1	1

Output State	Settings		
	Input	Control (Output Enable)	Output
Last_Known_State	Last_Known_State	Last_Known_State	Last_Known_State

Table Key:

- 1 – High: I/Os are set to drive out logic High
- 0 – Low: I/Os are set to drive out logic Low
- Last\_Known\_State - I/Os are set to the last value that was driven out prior to entering the programming mode, and then held at that value during programming

## Boundary Scan Registers - Enabled with Show BSR Details

Sets your I/O state to a specific output value during programming AND enables you to customize the values for the Boundary Scan Register (Input, Output Enable, and Output). You can change any Don't Care value in Boundary Scan Register States without changing the Output State of the pin (as shown in the table below).

For example, if you want to Tri-State a pin during programming, set Output Enable to 0; the Don't Care indicates that the other two values are immaterial.

If you want a pin to drive a logic High and have a logic 1 stored in the Input Boundary scan cell during programming, you may set all the values to 1.

Table 12 · BSR Details I/O Output Settings

Output State	Settings		
	Input	Output Enable	Output
Z (Tri-State)	Don't Care	0	Don't Care
0 (Low)	Don't Care	1	0
1 (High)	Don't Care	1	1
Last Known State	Last State	Last State	Last State

Table Key:

- 1 – High: I/Os are set to drive out logic High
- 0 – Low: I/Os are set to drive out logic Low
- Don't Care – Don't Care values have no impact on the other settings.

- Last\_Known\_State – Sampled value: I/Os are set to the last value that was driven out prior to entering the programming mode, and then held at that value during programming

The figure below shows an example of Boundary Scan Register settings.

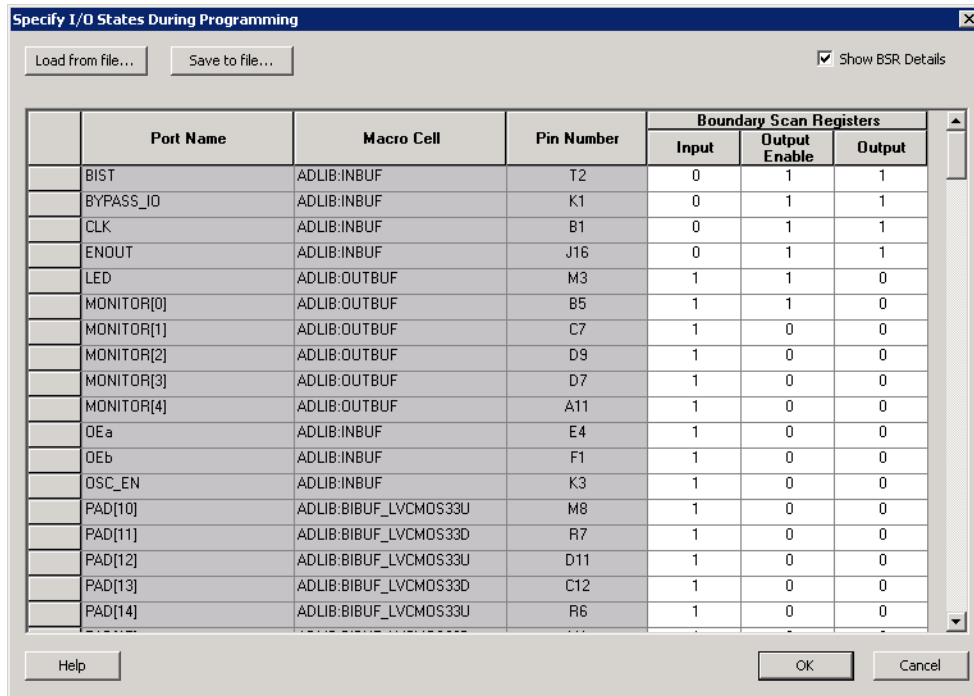

Figure 111 · Boundary Scan Registers

## Specify I/O States During Programming Dialog Box

The I/O States During Programming dialog box enables you to specify [custom settings](#) for I/Os in your programming file. This is useful if you want to set an I/O to drive out specific logic, or if you want to use a custom I/O state to manage settings for each Input, Output Enable, and Output associated with an I/O.

### Load from file

Load from file enables you to load an I/O Settings (\*.ios) file. You can use the IOS file to import saved custom settings for all your I/Os. The exported IOS file have the following format:

- Used I/Os have an entry in the IOS file with the following format:

```
set_prog_io_state -portName {<design_port_name>} -input <value> -outputEnable <value> -output <value>
```

- Unused I/Os have an entry in the IOS file with the following format:

```
set_prog_io_state -pinNumber {<device_pinNumber>} -input <value> -outputEnable <value> -output <value>
```

Where <value> is:

- 1 – I/O is set to drive out logic High
- 0 – I/O is set to drive out logic Low
- Last\_Known\_State: I/O is set to the last value that was driven out prior to entering the programming mode, and then held at that value during programming
- Z - Tri-State: I/O is tristated

### Save to file

Saves your I/O Settings File (\*.ios) for future use. This is useful if you set custom states for your I/Os and want to use them again later in conjunction with a PDC file.

### Port Name

Lists the names of all the ports in your design.

### Macro Cell

Lists the I/O type, such as INBUF, OUTBUF, PLLs, etc.

### Pin Number

The package pin associate with the I/O.

### I/O State (Output Only)

Your custom I/O State set during programming. This heading changes to Boundary Scan Register if you select the BSR Details checkbox; see the [Specifying I/O States During Programming - I/O States and BSR Details](#) help topic for more information on the BSR Details option.

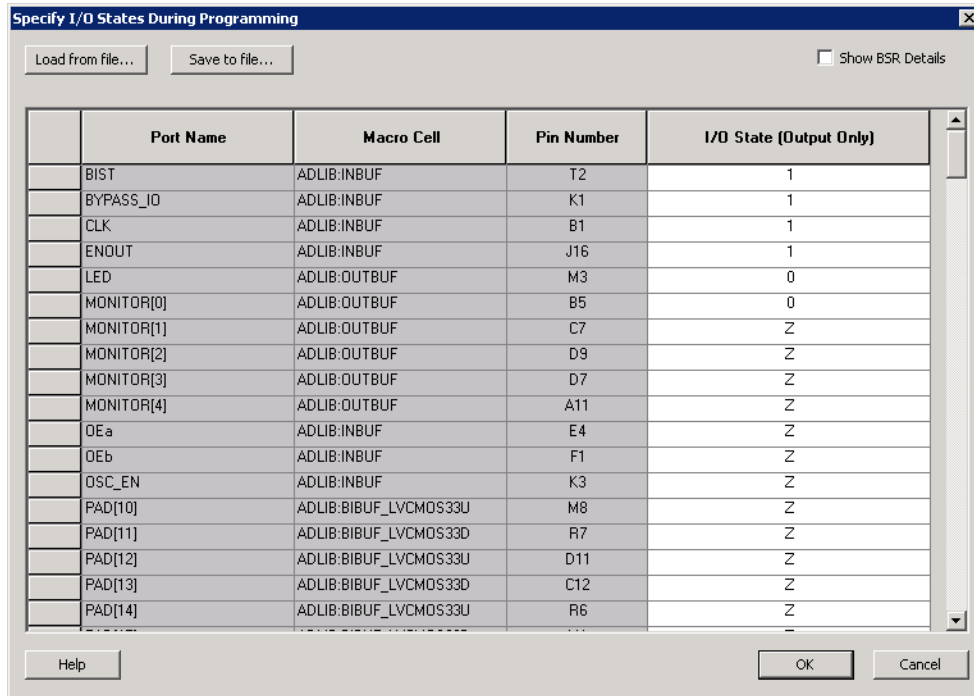

Figure 112 · I/O States During Programming Dialog Box

## FlashLock®

Actel's ProASIC and ProASIC<sup>PLUS</sup> devices contain FlashLock circuitry to lock the device by disabling the programming and readback capabilities after programming. Care has been taken to make the locking circuitry very difficult to defeat through electronic or direct physical attack.

FlashLock has three security options: No Lock, Permanent Lock, and Keyed Lock.

### No Lock

Creates a programming file which does not secure your device.

### Permanent Lock

The permanent lock makes your device one time programmable. It cannot be unlocked by you or anyone else.

### Keyed Lock

Within each ProASIC and ProASIC<sup>PLUS</sup> device, there is a multi-bit security key user key. The number of bits depends on the size of the device. The tables below show the key size of different ProASIC and ProASIC<sup>PLUS</sup> devices, respectively. Once secured, read permission and write permission can only be enabled by providing the correct user key to first unlock the device. The maximum security key for the device is shown in the dialog box.

Table 13 · Key Size of ProASIC Devices

Device	Key Size (bits)	Key Size (hex)
--------	-----------------	----------------

Device	Key Size (bits)	Key Size (hex)
A500K050	51 bits	13
A500K130	51 bits	13
A500K180	51 bits	13
A500K270	51 bits	13

Table 14 · Key Size of ProASIC<sup>PLUS</sup> Devices

Device	Key Size (bits)	Key Size (hex)
APA075	79 bits	20
APA150	79 bits	20
APA300	79 bits	20
APA450	119 bits	30
APA600	167 bits	42
APA750	191 bits	48
APA1000	263 bits	66

### Programming the Security Bit

Two device programmers, Silicon Sculptor and Flash Pro, are available for ProASIC and ProASIC<sup>PLUS</sup> devices. If the programming file contains the security key, by default the Silicon Sculptor and Flash Pro programming software automatically enables the "secure" option and programs the security key. You can turn this off, should you decide not to program using the security key.

Please refer to the application note [“Implementation of Security in Actel's ProASIC and ProASIC<sup>PLUS</sup> Flash-Based FPGAs”](#) for more details.

## Generating Bitstream and STAPL files

Bitstream allows you to generate a STAPL file for IGLOO, ProASIC3, SmartFusion, Fusion, ProASIC<sup>PLUS</sup>, and ProASIC devices, or a bitstream file for ProASIC and ProASICPLUS families. Please consult the [Program Files table](#) to find out which file type you should choose.



**To generate a bitstream or STAPL file:**

1. From the **Tools** menu, choose **Programming File**.
2. Select **Bitstream** or **STAPL** from the **File Type** drop-down list box. Bitstream files are not available for IGLOO, ProASIC3, SmartFusion and Fusion devices.
3. **FlashLock**. Select one of the following options:
  - **No Locking**: Creates a programming file which does not secure your device.
  - **Use Keyed Lock**: Creates a programming file which secures your device with a FlashLock key. The maximum security key for the device is shown in the dialog box. The maximum security key for the device is shown in the dialog box.
  - **Use Permanent Lock**: Creates a one-time programmable device.
4. Click **OK**. Designer validates the security key and alerts you to any concerns.

**Note:** Note: The bitstream file header contains the security key.

## Generating a Fuse File

Fuse allows you to generate a programming file for your Actel antifuse devices. Fuse files work with Actel's Silicon Sculptor programmers. (For Axcelerator families, you must use the Silicon Sculptor II programmer.)

**To generate a fuse programming file:**

1. From the **Tools** menu, choose **Programming File**.
2. **File Type**. Select the appropriate file type in the **File Type** drop-down menu. Select **AFM-APS2** if you are using Silicon Sculptor programmer.
3. **Silicon Signature** (Optional): Enter a 5 digit hexadecimal value in the Silicon Signature box to identify the design. Valid characters are 0 through 9, and a through f.
  - **Output filename**: Designer automatically names the file based on the *<design\_name>.adb* file. You can change the name by entering it in the **File Name** box. Click Browse to change the directory. Do not add a file extension or suffix to the file name. The Designer software automatically adds the extension to the programming file name when you specify the programming format.
  - **Generate Probe File Also**: This option automatically generates a PRB file for use with Silicon Explorer.
  - **Disable clamping diode for unused I/O pins**: (SX-A and eX families). Select box to disable clamping diode.
  - **Use the JTAG Reset Pull-up Resistor**: (Axcelerator family) Select to enable pull-up resistors on the TRSTB pin (JTAG Reset pin which is active low). This is not part of the JTAG standard but can be useful if you want to make sure that the JTAG tap controller is not reset by mistake if the TRSTB pin is not connected. The pull-up resistor guarantees that if the pin is not driven to low (active), the pin is left in an inactive state (high).
  - **Use the Global Set Fuse**: (Axcelerator family) Select to set flip-flops to a known state after power-up. If not selected all flip-flops are set to '0' at power up. If this option is used, all flip-flops are set to '1' at power up.

2. Click **OK** when finished to save the file.

## Generating Prototype Files

When designing for RTAX-S, you can use the Axcelerator family for prototyping. Please refer to the application note [Prototyping RTAX-S Using Axcelerator Devices](#) for more information.

Note: Designer maps the pins from the RT package to the commercial prototyping vehicle.

### **To generate prototype files:**

1. From the Designer **Tools** menu, choose **Generate Prototype**. This displays the Generate Prototype Files dialog box.
2. Set your **Prototype Die/Package**. The adapter socket required for prototyping varies depending on your target die/package.
  - For CQFB to FBGA, see the [COFB to FBGA Adapter Sockets application note](#).
  - For CCGA to FBGA, see the [CCGA to FBGA Adapter Sockets application note](#).
3. Set your [Silicon Signature](#) (optional) - Enter a 5 digit hexadecimal value in the Silicon Signature box to identify the design. Valid characters are '0' through '9', and 'a' through 'f'.
4. Select your **Output directory**. Click the Browse button to navigate to a directory.
5. Set options:
  - **Generate probe file also** - This option automatically generates a PRB file for use with Silicon Explorer
  - **Use the JTAG reset pull-up resistor** - Select to enable pull-up resistors on the TRSTB pin (JTAG Reset pin which is active low). This is not part of the JTAG standard but can be useful if you want to make sure that the JTAG tap controller is not reset by mistake if the TRSTB pin is not connected. The pull-up resistor guarantees that if the pin is not driven to low (active), the pin is left in an inactive state (high).
  - **Use the Global Set Fuse** - Select to set flip-flops to a known state after power-up. If not selected all flip-flops are set to '0' at power up. If this option is used, all flip-flops are set to '1' at power up.
6. Click **OK**. Designer runs through the process of creating the prototype files and generates the AFM for the selected die/package. After the prototype flow is complete, Designer automatically returns to the RT project. You must open your new prototyping ADB file manually to verify it.

## Saving your design

Once you have imported a netlist and compiled a design, you can save the design as an ADB file.

### **To save your design as an ADB file:**

1. From the **File** menu, choose **Save** or click the save icon in the toolbar.
2. Enter the File name and click **Save**. The default file name is the name you previously entered in the setup dialog box. The default format is ADB. Make sure you save your file in ADB format.

Once you have saved your compiled design as an ADB file, during any future Designer sessions, you can open the ADB file, skipping the compile step, and perform optimization on the design, including updating netlist and auxiliary file information.

## Exiting Designer

To end a Designer session, from the **File** menu, select **Exit**.

If the information has not been saved to disk, you are asked if you want to save the design before exiting. If you choose **YES**, the <design\_name>.adb file is updated with information entered the current session. If you choose **NO**, the information is not saved and the <design\_name>.adb file remains unchanged.

---

# **TCL Command Reference**

## Introduction to Tcl Scripting

Tcl, the Tool Command Language, pronounced *tickle*, is an easy-to-learn scripting language that is compatible with Libero IDE and Designer software. You can run scripts from either the Windows or UNIX command line or store and run a series of commands in a \*.tcl batch file.

This section provides a quick overview of the main features of Tcl:

- [Basic syntax](#)
- [Types of Tcl commands](#)
- [Variables](#)
- [Command substitution](#)
- [Quotes and braces](#)
- [Lists and arrays](#)
- [Control structures](#)
- [Handling exceptions](#)
- [Print statement and Return values](#)
- [Running Tcl scripts from the command line](#)
- [Running Tcl scripts from the GUI](#)
- [Exporting Tcl scripts](#)
- [Extended run\\_gui](#)
- [Extended run\\_shell](#)
- [Sample Tcl scripts](#)
- [Project Manager Tcl Commands](#)
- [Designer Tcl Commands](#)

For complete information on Tcl scripting, refer to one of the books available on this subject. You can also find information about Tcl at web sites such as <http://www.tcl.tk>.

## Basic syntax

Tcl scripts contain one or more commands separated by either new lines or semicolons. A Tcl command consists of the name of the command followed by one or more arguments. The format of a Tcl command is:

```
command arg1 ... argN
```

The command in the following example computes the sum of 2 plus 2 and returns the result, 4.

```
expr 2 + 2
```

The **expr** command handles its arguments as an arithmetic expression, computing and returning the result as a string.

All Tcl commands return results. If a command has no result to return, it returns an empty string.

To continue a command on another line, enter a backslash (\) character at the end of the line. For example, the following Tcl command appears on two lines:

```
import -format "edif" -netlist_naming "Generic" -edif_flavor "GENERIC" {prepi.edn}
```

Comments must be preceded by a hash character (#). The comment delimiter (#) must be the first character on a line or the first character following a semicolon, which also indicates the start of a new line. To create a multi-line comment, you must put a hash character (#) at the beginning of each line.

**Note:** Note: Be sure that the previous line does not end with a continuation character (\). Otherwise, the comment line following it will be ignored.

## Special characters

Square brackets ([ ]) are special characters in Tcl. To use square brackets in names such as port names, you must either enclose the entire port name in curly braces, for example, `pin_assign -port {LFSR_OUT[15]} -iostd lvttl -slew High`, or lead the square brackets with a slash (\) character as shown in the following example:

```
pin_assign -port LFSR_OUT\[15\] -iostd lvttl -slew High
```

## Sample Tcl script

```
#Set up a new design
new_design -name "multiclck" -family "Axcelerator" -path {.}

# Set device, package, speed grade, default I/O standard and
# operating conditions
set_device -die "AX1000" -package "BG729" -speed "-3" \
-voltage "1.5" -iostd "LVTTL" -temprange "COM" -voltrange "COM"

# Import the netlist
import -format "verilog" {multiclck.v}

# Compile the netlist
compile

# Import a PDC file
import_aux -format "pdc" {multiclck.pdc}

# Run standard layout
layout -incremental "OFF"

# Generate backannotated sdf and netlist file
backannotate -name {multiclck_ba} -format "sdf" -language "Verilog"

# Generate timing report
report -type "timing" -sortby "actual" -maxpaths "100" {report_timing.txt}

# Generate programming file
```

```
export -format "AFM" -signature "ffff" {multiclk.afm}
```

## Types of Tcl commands

There are three types of Tcl commands:

- [Built-in commands](#)
- [Procedures created with the proc command](#)
- [Commands built into the Designer software](#)

### Built-in commands

Built-in commands are provided by the Tcl interpreter. They are available in all Tcl applications. Here are some examples of built-in Tcl commands:

- Tcl provides several commands for manipulating file names, reading and writing file attributes, copying files, deleting files, creating directories, and so on.
- `exec` - run an external program. Its return value is the output (on stdout) from the program, for example:

```
set tmp [ exec myprog ]
puts stdout $tmp
```

- You can easily create collections of values (lists) and manipulate them in a variety of ways.
- You can create arrays - structured values consisting of name-value pairs with arbitrary string values for the names and values.
- You can manipulate the time and date variables.
- You can write scripts that can wait for certain events to occur, such as an elapsed time or the availability of input data on a network socket.

### Procedures created with the proc command

You use the `proc` command to declare a procedure. You can then use the name of the procedure as a Tcl command.

The following sample script consists of a single command named **proc**. The `proc` command takes three arguments:

- The name of a procedure (`myproc`)
- A list of argument names (`arg1 arg2`)
- The body of the procedure, which is a Tcl script

```
proc myproc { arg1 arg2 } {
# procedure body
}
myproc a b
```

## Commands built into the Designer software

Many functions that you can perform through the Designer software's GUI interface, you can also perform using an equivalent Tcl command. For example, the `backannotate` command is equivalent to executing the Back-Annotate command from Designer's Tools menu. For a list of Tcl commands supported in the Designer software, see "Tcl Commands."

## Variables

With Tcl scripting, you can store a value in a variable for later use. You use the `set` command to assign variables. For example, the following `set` command creates a variable named `x` and sets its initial value to 10.

```
set x 10
```

A variable can be a letter, a digit, an underscore, or any combination of letters, digits, and underscore characters. All variable values are stored as strings.

In the Tcl language, you do not declare variables or their types. Any variable can hold any value. Use the dollar sign (\$) to obtain the value of a variable, for example:

```
set a 1
set b $a
set cmd expr
set x 11
$cmd $x*$x
```

The dollar sign \$ tells Tcl to handle the letters and digits following it as a variable name and to substitute the variable name with its value.

## Global Variables

Variables can be declared global in scope using the Tcl `global` command. All procedures, including the declaration can access and modify global variables, for example:

```
global myvar
```

## Command substitution

By using square brackets ([ ]), you can substitute the result of one command as an argument to a subsequent command, as shown in the following example:

```
set a 12
set b [expr $a*4]
```

Tcl handles everything between square brackets as a nested Tcl command. Tcl evaluates the nested command and substitutes its result in place of the bracketed text. In the example above, the argument that appears in square brackets in the second `set` command is equal to 48 (that is,  $12 * 4 = 48$ ).

Conceptually,

```
set b [expr $a * 4]
```

expands to



```

set b [expr 12 * 4 ]
and then to
set b 48

```

## Quotes and braces

The distinction between braces ({} ) and quotes (" ") is significant when the list contains references to variables. When references are enclosed in quotes, they are substituted with values. However, when references are enclosed in braces, they are not substituted with values.

Example

With Braces	With Double Quotes
set b 2	set b 2
set t { 1 \$b 3 }	set t " 1 \$b 3 "
set s { [ expr \$b + \$b ] }	set s " [ expr \$b + \$b ] "
puts stdout \$t	puts stdout \$t
puts stdout \$s	puts stdout \$s

will output

```

1 $b 3
[ expr $b + $b ]

```

VS.

```

1 2 3
4

```

## Filenames

In Tcl syntax, filenames should be enclosed in braces {} to avoid backslash substitution and white space separation. Backslashes are used to separate folder names in Windows-based filenames. The problem is that sequences of “\n” or “\t” are interpreted specially. Using the braces disables this special interpretation and specifies that the Tcl interpreter handle the enclosed string literally. Alternatively, double-backslash “\\n” and “\\t” would work as well as forward slash directory separators “/n” and “/t”. For example, to specify a file on your Windows PC at c:\newfiles\thisfile.adb, use one of the following:

```

{C:\newfiles\thisfile.adb}
C:\\newfiles\\thisfile.adb
"C:\\newfiles\\thisfile.adb"
C:/newfiles/thisfile.adb
"C:/newfiles/thisfile.adb"

```

If there is white space in the filename path, you must use either the braces or double-quotes. For example:

```

C:\program data\thisfile.adb

```

should be referenced in Tcl script as

```
{C:\program data\thisfile.adb} or "C:\\program data\\thisfile.adb"
```

If you are using variables, you cannot use braces { } because, by default, the braces turn off all special interpretation, including the dollar sign character. Instead, use either double-backslashes or forward slashes with double quotes. For example:

```
"$design_name.adb"
```

**Note:** Note: To use a name with special characters such as square brackets [ ], you must put the entire name between curly braces { } or put a slash character \ immediately before each square bracket.

The following example shows a port name enclosed with curly braces:

```
pin_assign -port {LFSR_OUT[15]} -iostd lvttl -slew High
```

The next example shows each square bracket preceded by a slash:

```
pin_assign -port LFSR_OUT\[15\] -iostd lvttl -slew High
```

## Lists and arrays

A list is a way to group data and handle the group as a single entity. To define a list, use curly braces { } and double quotes “. For example, the following set command {1 2 3 }, when followed by the list command, creates a list stored in the variable "a." This list will contain the items "1," "2," and "3."

```
set a { 1 2 3 }
```

Here's another example:

```
set e 2
set f 3
set a [ list b c d [ expr $e + $f ] ]
puts $a
```

displays (or outputs):

```
b c d 5
```

Tcl supports many other list-related commands such as lindex, linsert, llength, lrange, and lappend. For more information, refer to one of the books or web sites available on this subject.

## Arrays

An array is another way to group data. Arrays are collections of items stored in variables. Each item has a unique address that you use to access it. You do not need to declare them nor specify their size.

Array elements are handled in the same way as other Tcl variables. You create them with the set command, and you can use the dollar sign (\$) for their values.

```
set myarray(0) "Zero"
set myarray(1) "One"
set myarray(2) "Two"
for {set i 0} {$i < 3} {incr i 1} {
```

Output:

```
Zero
One
```

Two

In the example above, an array called "myarray" is created by the set statement that assigns a value to its first element. The for-loop statement prints out the value stored in each element of the array.

## Special arguments (command-line parameters)

You can determine the name of the Tcl script file while executing the Tcl script by referring to the \$argv0 variable.

```
puts "Executing file $argv0"
```

To access other arguments from the command line, you can use the lindex command and the argv variable:

To read the the Tcl file name:

```
lindex $argv 0
```

To read the first passed argument:

```
lindex $argv 1
```

Example

```
puts "Script name is $argv0" ; # accessing the scriptname
puts "first argument is [lindex $argv 0]"
puts "second argument is [lindex $argv 1]"
puts "third argument is [lindex $argv 2]"
puts "number of argument is [lindex $argv 2]"
set des_name [lindex $argv 0]
puts "Design name is $des_name"
```

## Control structures

Tcl control structures are commands that change the flow of execution through a script. These control structures include commands for conditional execution (if-then-elseif-else) and looping (while, for, catch).

An "if" statement only executes the body of the statement (enclosed between curly braces) if the Boolean condition is found to be true.

### if/else statements

```
if { "$name" == "paul" } then {
...
# body if name is paul
} elseif { $code == 0 } then {
...
# body if name is not paul and if value of variable code is zero
} else {
...
# body if above conditions is not true
}
```

### for loop statement

A "for" statement will repeatedly execute the body of the code as long as the index is within a specified limit.

```

for { set i 0 } { $i < 5 } { incr i } {
...
# body here
}

```

## while loop statement

A "while" statement will repeatedly execute the body of the code (enclosed between the curly braces) as long as the Boolean condition is found to be true.

```

while { $p > 0 } {
...
}

```

## catch statement

A "catch" statement suspends normal error handling on the enclosed Tcl command. If a variable name is also used, then the return value of the enclosed Tcl command is stored in the variable.

```

catch { open "$inputFile" r } myresult

```

## Handling exceptions (Tcl scripting)

To control the flow of the Designer software based on certain conditions (for example, success or failure of certain commands), you can use the Tcl built-in catch command as follows:

```

if { [ catch {open_design $des_name.adb} ] } {
    puts "Cannot open $des_name.adb"
    export -format "log" -diagnostic $des_name.log"
    exit 1
} else {
    puts "Design $des_name.adb Successfully Opened"
}
## set layout mode to standard
layout -incremental "OFF"
if { [ catch {layout} ] } {
    puts "Layout Failed"
    export -format "log" -diagnostic $des_name.log"
    exit 1
} else {
    puts "layout successful"
    export -format log "$des_name.log"
    save_design "$des_name.adb";
    close_design
}

```

## Print statement and Return values

### Print Statement

Use the puts command to write a string to an output channel. Predefined output channels are “stdout” and “stderr.” If you do not specify a channel, then puts display text to the stdout channel.

**Note:** Note: The STDIN Tcl command is not supported by Actel tools.

Example:

```
set a [ myprog arg1 arg2 ]
puts "the answer from myprog was $a (this text is on stdout)"
puts stdout "this text also is on stdout"
```

### Return Values

The return code of a Tcl command is a string. You can use a return value as an argument to another function by enclosing the command with square brackets [ ].

Example:

```
set a [ prog arg1 arg2 ]
exec $a
```

The Tcl command “exec” will run an external program. The return value of “exec” is the output (on stdout) from the program.

Example:

```
set tmp [ exec myprog ]
puts stdout $tmp
```

## Running Tcl scripts from the GUI

Instead of running scripts from the command line, you can use Execute Script dialog box to run a script in the Project Manager or Designer.

### **To run a Tcl script from the GUI:**

1. In Project Manager, from the **Project** menu choose **Execute Script**.  
In Designer, from the **File** menu choose **Execute Script**. This opens the Execute Script dialog box (as shown in the figure below).

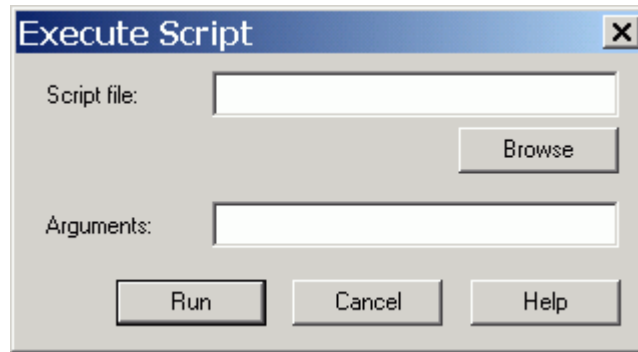

Figure 113 · Execute Script Dialog Box

2. Click **Browse** to display the **Open** dialog box, in which you can navigate to the folder containing the script file to open. When you click **Open**, Designer enters the full path and script filename into the Execute Script dialog box for you.
3. In the Arguments edit box, enter the arguments to pass to your Tcl script as shown in the following sample Execute Script dialog box. Separate each argument by a space character. For information about accessing arguments passed to a Tcl script, see "Running Scripts from the command line."

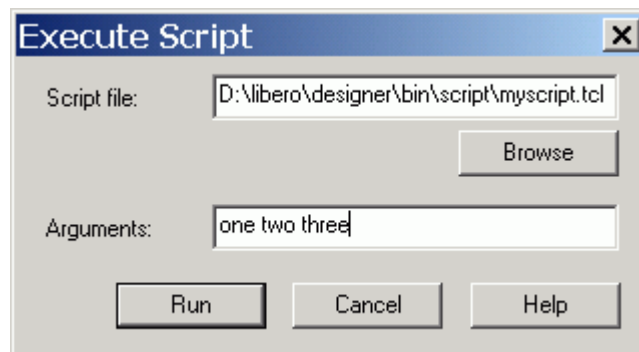

Figure 114 · Execute Script Dialog Box Example

4. Click **Run**.

Specify your arguments in the Execute Script dialog box. To get those argument values from your Tcl script, use the following:

```
puts "Script name: $argv0"
puts "Number of arguments: $argc"
set i 0
foreach arg $argv {
    puts "Arg $i : $arg"
    incr i
}
```

## Running Tcl scripts from the command line

You can run Tcl scripts from your Windows or Unix command line as well as pass arguments to scripts from the command line.

### **To execute a Tcl script file in the Libero IDE Project Manager software from a shell command line:**

At the prompt, type the path to the Actel software followed by the word "SCRIPT" and a colon, and then the name of the script file as follows:

```
<location of Actel software>\bin\libero SCRIPT:<filename>
```

where <location of Actel software> is the root directory in which you installed the Actel software, and <filename> is the name, including a relative or full path, of the Tcl script file to execute. For example, to run the Tcl script file "myscript.tcl", type:

```
C:\libero\designer\bin\libero SCRIPT:myscript.tcl
```

If `myscript.tcl` is in a particular folder named "mydesign", you can use `SCRIPT_DIR` to change the current working directory before calling the script, as in the following example:

```
C:\libero\designer\bin\libero SCRIPT:myscript.tcl "SCRIPT_DIR:C:\actelprj\mydesign"
```

### **To execute a Tcl script file in the Designer software from a shell command line:**

At the prompt, type the path to the Actel software followed by the word "SCRIPT" and a colon, and then the name of the script file as follows:

```
<location of Actel software>\bin\designer SCRIPT:<filename>
```

where <location of Actel software> is the root directory in which you installed the Actel software, and <filename> is the name, including a relative or full path, of the Tcl script file to execute.

For example, to run the Tcl script file named "myscript.tcl" from the command line, you can type:

```
C:\libero\designer\bin\designer SCRIPT:myscript.tcl
```

If `myscript.tcl` is in a particular folder named "mydesign", you can use `SCRIPT_DIR` to change the current working directory before calling the script, as in the following example:

```
C:\libero\designer\bin\designer SCRIPT:myscript.tcl "SCRIPT_DIR:C:\actelprj\mydesign"
```

### **To pass arguments from the command line to your Tcl script file:**

At the prompt, type the path to the Actel software followed by the `SCRIPT` argument. Enclose the entire argument expression in double quotes:

```
<location of Actel software>\bin\designer "SCRIPT:<filename arg1 arg2 ...>"
```

where <location of Actel software> is the root directory in which you installed the Actel software, and <filename arg1 arg2 ...> is the name, including a relative or full path, of the Tcl script file and arguments you are passing to the script file.

For example,

```
C:\libero\designer\bin\designer "SCRIPT:myscript.tcl one two three"
```

### **To obtain the output from the log file:**

At the prompt, type the path to the Actel software followed by the `SCRIPT` and `LOGFILE` arguments.

```
<location of Actel software>\bin\designer "SCRIPT:<filename arg1 arg2 ...>  
LOGFILE:<output.log>"
```

where <location of Actel software> is the root directory in which you installed the Actel software, <filename arg1 arg2 ...> is the name, including a relative or full path, of the Tcl script file and arguments you are passing to the script file, and `output.log` is the name of the log file.

For example,

```
C:\libero\designer\bin\designer "SCRIPT:mymyscript.tcl one two three" "LOGILE:output.log"
```

## Exporting Tcl scripts

You can write out a Tcl script file that contains the commands executed in the current session. You can then use this exported Tcl script to re-execute the same commands interactively or in batch. You can also use this exported script to become more familiar with Tcl syntax.

You can export Tcl scripts from the Project Manager or Designer; the actions are the same.

### To export a Tcl session script from the Project Manager or Designer:

1. From the **File** menu, choose **Export>Script Files**. The **Export Script Files** dialog box appears.
2. From the **Save in** drop-down menu, navigate to the folder in which you want to save the script files.
3. Type a filename for this Tcl script file.
4. Click **Save**. The **Script Export Options** dialog box appears

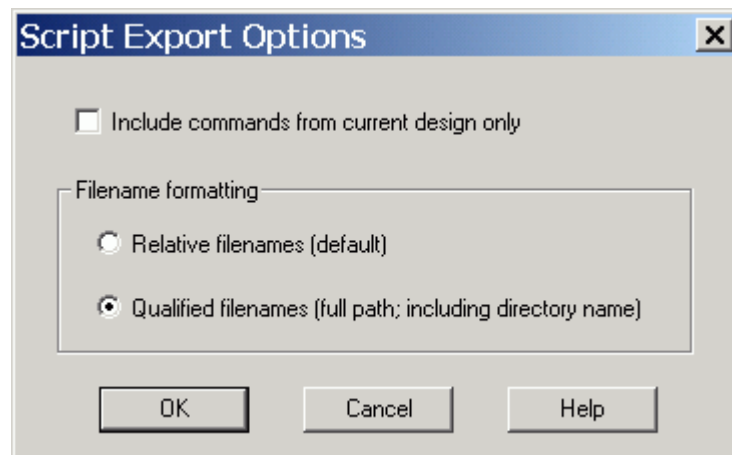

Figure 115 · Script Export Options

5. Check the **Include Commands from Current Design [Project] Only** checkbox. This option applies only if you opened more than one design or project in your current session. If so, and you do not check this box, Project Manager / Designer exports all commands from your current session.
6. Select the radio button for the appropriate filename formatting. To export filenames relative to the current working directory, select **Relative filenames (default)** formatting. To export filenames that include a fully specified path, select **Qualified filenames (full path; including directory name)** formatting.



Choose **Relative filenames** if you do not intend to move the Tcl script from the saved location, or **Qualified filenames** if you plan to move the Tcl script to another directory or machine.

7. Click **OK**.

Project Manager / Designer saves the Tcl script with the specified filename.

**Note:** Notes:

- When exporting Tcl scripts, Project Manager and Designer always encloses filenames in curly braces to ensure portability.
- Project Manager and Designer software do not write out any Tcl variables or flow-control statements to the exported Tcl file, even if you had executed the design commands using your own Tcl script. The exported Tcl file only contains the tool commands and their accompanying arguments.

## extended\_run\_gui - Designer Only

This script is used to reproduce the GUI behavior and is more suited for running through Designer or inside another Designer TCL script.

The only difference from the extended\_run\_shell Tcl script is that the extended\_run\_gui.tcl script does not need the -adb argument and assumes that the design is already saved and open.

```
extended_run_gui.tcl [-n numPasses] [-starting_seed_index numIndex] [-save_all] [-compare_criteria value] [-c clockName] [-analysis value] [-slack_criteria value] [-timing_driven|-standard] [-stop_on_success] [-run_placer value] [-place_incremental value] [-route_incremental value] [-effort_level numLevel] [-timing_weight numWeight] [-placer_high_effort value] [-mindel_repair value] [-power_driven value]
```

### To invoke extended\_run\_gui from Designer:

1. Open an \*.adb file in Designer.
2. From the **File** menu, select **Execute Script**. This opens the Execute Script dialog box.

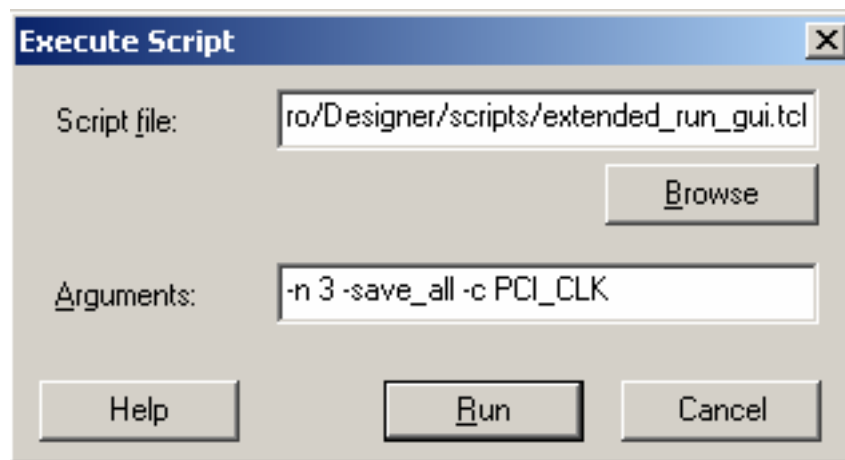

Figure 116 · Execute Script Dialog Box

3. Find the `extended_run-gui.tcl` script under `ACTEL_SW_DIR/scripts` and then copy all the parameters in to the arguments section.
4. Click **Run**.

**To invoke `extended_run_gui` from within a TCL script:**

1. Save the design in compiled state.

```
...
compile
save_design "my.adb"
```

2. Override the original argument list in the caller script and then source the `extended_run_gui.tcl` script.

```
set save_argv0 $::argv0
set save_argv $::argv
set ACTEL_SW_DIR $env(ACTEL_SW_DIR)
set ::argv0 "$ACTEL_SW_DIR/scripts/extended_run_gui.tcl"
set ::argv [list -n 3 -save_all -c PCI_CLK]
set ::argc [llength $::argv]
source $::argv0
set ::argv0 $save_argv0
set ::argv $save_argv
set ::argc [llength $::argv]
```

**See Also**

[Running Layout](#)

[Multiple Pass Layout](#)

[extended\\_run\\_shell](#)

## extended\_run\_shell - Designer Only

**Note:** Note: This is not a Tcl command; it is a shell script that can be run from the command line. To invoke multiple pass layout within another Designer Tcl script, refer to [extended\\_run\\_gui](#).

The `extended_run_shell` Tcl script enables you to run the multiple pass layout in batch mode from a command line.

Use this script from the tcl shell "acttclsh". **This is the script or command-line equivalent to using the multiple pass layout in the GUI.**

```
$ACTEL_SW_DIR/bin/acttclsh extended_run_shell.tcl -adb adbFileName.adb [-n numPasses] [-starting_seed_index numIndex] [-save_all] [-compare_criteria value] [-c clockName] [-analysis value] [-slack_criteria value] [-timing_driven|-standard] [-stop_on_success] [-run_placer value] [-place_incremental value] [-route_incremental value] [-effort_level numLevel] [-timing_weight numWeight] [-placer_high_effort value] [-mindel_repair value] [-power_driven value]
```

## Arguments

`-adb adbFileName.adb`

This is the design file to run multiple passes of layout.

`[-n numPasses]`

Sets the number of passes to run. The default number of passes is 5.

`[-starting_seed_index numIndex]`

Indicates the specific index into the array of random seeds which is to be the starting point for the passes. Its value should range from 1 to 101. If not specified, the default behavior is to continue from the last seed index which was used.

`[-save_all]`

Saves all intermediate designs in `<adbFileName>_r<runNum>_s<seedIndex>.adb`. The best result is also stored to the original \*.adb file as well. The default behavior does not save all results.

`[-compare_criteria value]`

The following table shows the acceptable values for this argument:

Value	Description
frequency	Sets the criteria for comparing results between passes to be clock frequency based. This is the default. This option enables the <code>-c</code> option (described below).
violations	Sets the criteria for comparing results between passes to be timing violations (slack) based. This option enables the <code>-analysis</code> , <code>-slack_criteria</code> , and <code>-stop_on_success</code> options (described below).
power	Sets the criteria for comparing results between passes to be based on the lowest total power.

`[-c clockName]`

Applies only when the clock frequency comparison criteria is used. Specifies the particular clock that is to be examined. If no clock is specified, then the slowest clock frequency in the design in a given pass is used.

`[-analysis value]`

Applies only when the timing violations comparison criteria is used. The following table shows the acceptable values for this argument:

Value	Description
max	Examines timing violations (slacks) obtained from maximum delay analysis. This is the default.
min	Examines timing violations (slacks) obtained from minimum delay analysis.

`[-slack_criteria value]`

Applies only when the timing violations comparison criteria is used. The type of timing violations (slacks) is determined by the `-analysis` option. The following table shows the acceptable values for this argument:

Value	Description
worst	Sets the timing violations criteria to worst slack. For each pass obtains the most amount of negative slack (or least amount of positive slack if all constraints are met) from the timing violations report. The largest value out of all passes will determine the best pass. This is the default.
tns	Sets the timing violations criteria to total negative slack. For each pass obtains the sum of negative slacks from the first 100 paths from the timing violations report. The largest value out of all passes will determine the best pass. If no negative slacks exist for a pass, then the worst slack is used to evaluate that pass

`[-stop_on_success]`

Applies only when the timing violations comparison criteria is used. The type of timing violations (slacks) is determined by the `-analysis` option. Stops performing remaining passes if all timing constraints have been met (when there are no negative slacks reported in the timing violations report).

`[-timing_driven|-standard]`

Sets layout mode to be timing driven or standard (non-timing driven). The default is `-timing_driven` or the mode used in the previous layout command.

`[-run_placer value]`

The following table shows the acceptable values for this argument:

Value	Description
on	Invokes placer. This is the default.
off	Skips placer.

`[-place_incremental value]`

The following table shows the acceptable values for this argument:

Value	Description
off	Discards previous placement. This is the default.
on	Sets the previous placement as the initial starting point for each pass.
fix	Locks previous placement for each pass.

`[-route_incremental value]`

The following table shows the acceptable values for this argument:

Value	Description
-------	-------------

Value	Description
off	Discards previous routing. This is the default.
on	Sets the previous routing as the initial starting point for each pass.

`[-effort_level numLevel]`

This is an advanced option that is available only for Axcelerator, SX-A, and eX. It specifies the placement effort level.

`[-timing_weight numWeight]`

This is an advanced option that is available only for ProASIC<sup>PLUS</sup>, ProASIC, SX-A, and eX. It specifies the layout timing weight.

`[-placer_high_effort value]`

This is an advanced option that is available only for IGLOO, ProASIC3, SmartFusion and Fusion families. The following table shows the acceptable values for this argument:

Value	Description
off	Runs layout in regular effort. This is the default.
on	Activates high effort layout mode.

`[-mindel_repair value]`

This is an advanced option that is available only for IGLOO, ProASIC3, SmartFusion and Fusion families. The following table shows the acceptable values for this argument:

Value	Description
off	Does not run minimum delay violations repair. This is the default.
on	Enables repair of minimum delay violations during route.

`[-power_driven value]`

This option is available only for IGLOO, ProASIC3, SmartFusion, Fusion, and Axcelerator families. The following table shows the acceptable values for this argument:

Value	Description
off	Does not run power-driven layout. This is the default.
on	Enables power-driven layout.

## Return

A non-zero value will be returned on error.

## Supported Families

IGLOO, ProASIC3, SmartFusion, Fusion, ProASIC<sup>PLUS</sup>, ProASIC, Axcelerator, eX, and SX-A

## Exceptions

None

## Example

1. On *my.adb*, run 5 (default) passes continuing from the last seed index using slowest clock frequency (default) comparison criteria.  

```
% acttclsh extended_run_shell.tcl -adb my.adb
```
2. On *my.adb*, run 3 passes starting with seed index 6, saving all results, using clock frequency comparison criteria for clock "PCI\_CLK".  

```
% acttclsh extended_run_shell.tcl -adb my.adb -n 3 -starting_seed_index 6 -save_all -c PCI_CLK
```
3. On *my.adb*, run 5 (default) passes continuing from the last seed index, saving all results, using timing violations comparison criteria with maximum delay (default) analysis and worst slack (default) criteria; invoke high effort layout.  

```
% acttclsh extended_run_shell.tcl -adb my.adb -save_all -compare_criteria violations -placer_high_effort on
```
4. On *my.adb*, run 5 (default) passes continuing from the last seed index, saving all results, using timing violations comparison criteria with maximum delay (default) analysis and total negative slack criteria; invoke placement effort level 5.  

```
% acttclsh extended_run_shell.tcl -adb my.adb -save_all -compare_criteria violations -slack_criteria tns -effort_level 5
```
5. On *my.adb*, run 5 (default) passes continuing from the last seed index, saving all results, using timing violations comparison criteria with minimum delay analysis and worst slack (default) criteria; stop if there are no violations.  

```
% acttclsh extended_run_shell.tcl -adb my.adb -save_all -compare_criteria violations -analysis min -stop_on_success
```
6. On *my.adb*, run 5 (default) passes continuing from the last seed index, saving all results, using timing violations comparison criteria with minimum delay analysis and total negative slack criteria; invoke repair of minimum delay violations.  

```
% acttclsh extended_run_shell.tcl -adb my.adb -save_all -compare_criteria violations -analysis min -slack_criteria tns -mindel_repair on
```

## See Also

[Running Layout](#)

[Multiple Pass Layout](#)

[extended\\_run\\_gui](#)

## Sample Tcl Script - Designer

The following script creates a new design named *prepi* for the SX-A family:

```
#Set up a new design
new_design -name "prepi" -family "SXA"
#set device name, package name
set_device -die "A54SX32A" -package "176 TQFP"
#set device speed and operating conditions
set_device -speed "-1" -temprange "com" -voltrange "com"
#import netlist and pin files
import -format "edif" -netlist_naming "Generic" \
-edif_flavor "GENERIC" {prepi.edn}
import -format "pin" {prepi.pin}
compile
#layout standard mode
layout -incremental "OFF"
#extract sdf file
export -format "sdf" {prepi.sdf}
save_design {prepi.adb}
close_design
```

**Note:** Note: The comment delimiter, which is the pound sign (#), must be the first non-space character on a line or the first character following a semicolon (in Tcl, commands are separated by new lines or semicolons).

## Sample Tcl Script - Project Manager

The following Tcl commands create a new project named *proj1* and sets your project options.

```
#Create new project
new_project -name proj1 -location c:/actelprj -family fusion -die AFS090 -package "108
QFN" -hdl VHDL
#Import HDL source file named hdlsource1.vhd
import_files -hdl_source c:\hdlsource1.vhd
#Run synthesis and create a logfile named synth1.
run_synthesis -logfile synth.log
# he default ADB file, run Compile, run Layout
run_designer -logfile designer_log -adb new -compile TRUE -layout TRUE -export_ba TRUE
```

## Tcl Flow in the Libero IDE

Use the following commands to manage and build your project in the Libero IDE.

### Design Flow in the Project Manager

The Tcl commands below outline the entire design flow. Once you create a project in the Project Manager you can use the commands below to complete every operation from synthesis to generating an HDL netlist. Click any command to go to the command definition.

[run\\_synthesis](#) [-logfile *name*]

```

run_simulation [-logfile name]
check_hdl -file filename
check_schematic -file filename
create_symbol [-module module]
export_io_constraints_from_adb -adb filename -output outputfilename
generate_ba_files -adb filename
generate_hdl_from_schematic [-module modulename]
generate_hdl_netlist [-netlist filename] [-run_drc "TRUE | FALSE"]
rollback_constraints_from_adb -adb filename -output output_filename
run_designer [-logfile filename] [-script "script to append"] [-append_commands "commands to execute"] [-adb "new | open | default"] [-compile "TRUE | FALSE"] [-layout "TRUE | FALSE"] [-export_ba "TRUE | FALSE"]
run_drc [-netlist file] [-gen_hdl "TRUE | FALSE"]

```

## Manage Profiles in the Project Manager

```

add_profile -name profilename -type "synthesis | simulation | stimulus | flashpro | physynth | coreconfig" -tool profiletool -location tool_location [-args tool_parameters] [-batch "TRUE | FALSE"]
edit_profile -name profilename -type "synthesis | simulation | stimulus | flashpro | physynth | coreconfig" -tool profiletool -location tool_location [-args tool_parameters] [-batch "TRUE | FALSE"] [-new_name name]
export_profiles -file name [-export "predefined | user | all"]
remove_profile -name profile_name
select_profile -name profile_name

```

## Linking Files

```

change_link_source -file filename -path pathname
create_links [-hdl_source file]* [-stimulus file]* [-sdc file]* [-pin file]* [-dcf file]* [-gcf file]* [-pdc file]* [-crt file]* [-vcd file]*
export_as_link -file filename -path link_path
unlink -file file [-local local_filename]

```

## Set Simulation Options in the Project Manager

```

add_modelsim_path -lib library_name [-path library_path] [-remove " "]

```

## Set Device in the Project Manager

```

set_device [-family family] [-die die] [-package package]

```

## Miscellaneous Operations in the Project Manager

```

project_settings [-hdl "VHDL | VERILOG"] [-auto_update_modelsim_ini "TRUE | FALSE"] [-auto_update_viewdraw_ini "TRUE | FALSE"] [-block_mode "TRUE | FALSE"] [-

```



```
auto_generate_synth_hdl "TRUE / FALSE" [-auto_generate_physynth_hdl "TRUE / FALSE" [-
auto_run_drc "TRUE / FALSE" ] [-auto_generate_viewdraw_hdl "TRUE / FALSE" ] [-
auto_file_detection "TRUE / FALSE" ]
```

[refresh](#)

```
set_option [-synth "TRUE / FALSE" ] [-physynth "TRUE / FALSE" ] [-module "module" ]
```

```
remove_core -name core_name
```

## Project Manager Tcl Command Reference

A Tcl (Tool Command Language) file contains scripts for simple or complex tasks. You can run scripts from either the Windows or UNIX command line or store and run a series of Tcl commands in a \*.tcl batch file. You can also run scripts from [within the GUI](#) in Project Manager.

**Note:** Note: Tcl commands are case sensitive. However, their arguments are not.

The Libero IDE Project Manager supports the following Tcl scripting commands:

Command	Action
<a href="#">add_file_to_library</a>	Adds a file to a library in your project
<a href="#">add_library</a>	Adds a VHDL library to your project
<a href="#">add_modelsim_path</a>	Adds a ModelSim simulation library to your project
<a href="#">add_profile</a>	Adds a profile; sets the same values as the <a href="#">Add or Edit Profile dialog box</a>
<a href="#">associate_stimulus</a>	Associates a stimulus file in your project
<a href="#">change_link_source</a>	Changes the source of a linked file in your project
<a href="#">check_hdl</a>	Checks the HDL in the specified file
<a href="#">check_schematic</a>	Checks the schematic
<a href="#">close_project</a>	Closes the current project in Libero IDE
<a href="#">create_links</a>	Creates a link (or links) to a file/files in your project
<a href="#">create_symbol</a>	Creates a symbol in a module
<a href="#">delete_files</a>	Deletes files from your Libero IDE project
<a href="#">edit_profile</a>	Edits a profile; sets the same values as the <a href="#">Add or Edit Profile dialog box</a>

Command	Action
<a href="#">export as link</a>	Exports a file to another directory and links to the file
<a href="#">export io constraints from adb</a>	Exports the I/O constraints from your project ADB file to an output file
<a href="#">export profiles</a>	Exports your tool profiles; performs the same action as the <a href="#">Export Profiles dialog box</a>
<a href="#">generate ba files</a>	Generates the back-annotate files for your design
<a href="#">generate hdl from schematic</a>	Generates an HDL file from your schematic
<a href="#">generate hdl netlist</a>	Generates the HDL netlist for your design and runs the design rule check
<a href="#">import files</a> (Liberio IDE)	Imports files into your Liberio IDE project
<a href="#">new project</a>	Creates a new project in the Liberio IDE
<a href="#">open project</a>	Opens an existing Liberio IDE project
<a href="#">organize cdb</a> s	Organizes the CDB files in your project
<a href="#">organize constraints</a>	Organizes the constraint files in your project
<a href="#">organize sources</a>	Organizes the source files in your project
<a href="#">project settings</a>	Modifies project flow settings for your Liberio IDE project
<a href="#">remove core</a>	Removes a core from your project
<a href="#">remove library</a>	Removes a VHDL library from your project
<a href="#">remove profile</a>	Deletes a tool profile
<a href="#">rename library</a>	Renames a VHDL library in your project
<a href="#">rollback constraints from adb</a>	Opens the ADB file, exports the PDC file, and then replaces it with the specified PDC file
<a href="#">run designer</a>	Runs Designer with compile and layout options (if selected)

Command	Action
<a href="#">run_drc</a>	Runs the design rule check on your netlist and generates an HDL file
<a href="#">run_simulation</a>	Runs simulation on your project with your default simulation tool and creates a logfile
<a href="#">run_synthesis</a>	Runs synthesis on your project and creates a logfile
<a href="#">save_log</a>	Saves your Libero IDE log file
<a href="#">save_project</a>	Saves your project
<a href="#">save_project_as</a>	Saves your project with a different name
<a href="#">select_profile</a>	Selects a profile to use in your project
<a href="#">set_actel_lib_options</a>	Sets your simulation library to default, or to another library
<a href="#">set_device (Project Manager)</a>	Sets your device family, die, and package in the Project Manager
<a href="#">set_modelsim_options</a>	Sets your ModelSim simulation options
<a href="#">set_option</a>	Sets your synthesis options on a module
<a href="#">set_userlib_options</a>	Sets your user library options during simulation
<a href="#">set_root</a>	Sets the module you specify as the root
<a href="#">synplify</a>	Runs Synplify in batch mode and executes a Tcl script.
<a href="#">synplify_pro</a>	Runs Synplify Pro in batch mode and executes a Tcl script.
<a href="#">unlink</a>	Removes a link to a file in your project
<a href="#">use_file</a>	Specifies which file in your project to use
<a href="#">use_source_file</a>	Defines a module for your project

## Tcl command documentation conventions

The following table shows the typographical conventions used for the Tcl command syntax.

Syntax Notation	Description
command - argument	Commands and arguments appear in Courier New typeface.
<i>variable</i>	<i>Variables appear in blue, italic Courier New typeface. You must substitute an appropriate value for the variable.</i>
[-argument <i>value</i> ] [ <i>variable</i> ]+	Optional arguments begin and end with a square bracket with one exception: if the square bracket is followed by a plus sign (+), then users must specify at least one argument. The plus sign (+) indicates that items within the square brackets can be repeated. Do not enter the plus sign character.

**Note:** Note: All Tcl commands are case sensitive. However, their arguments are not.

### Examples

Syntax for the `get_defvar` command followed by a sample command:

```
get_defvar variable
```

```
get_defvar "DESIGN"
```

Syntax for the `backannotate` command followed by a sample command:

```
backannotate -name file_name -format format_type -language language -dir directory_name [-netlist] [-pin]
```

```
backannotate -dir \  
{..\design} -name "fanouttest_ba.sdf" -format "SDF" -language "VERILOG" \  
-netlist
```

### Wildcard Characters

You can use the following wildcard characters in names used in Tcl commands:

Wildcard	What it Does
\	Interprets the next character literally
?	Matches any single character
*	Matches any string

Wildcard	What it Does
[ ]	Matches any single character among those listed between brackets (that is, [A-Z] matches any single character in the A-to-Z range)

**Note:** Note: The matching function requires that you add a slash (\) before each slash in the port, instance, or net name when using wildcards in a PDC command and when using wildcards in the Find feature of the MultiView Navigator. For example, if you have an instance named “A/B12” in the netlist, and you enter that name as “A\\B\*” in a PDC command, you will not be able to find it. In this case, you must specify the name as A\\B\*.

## Special Characters [ ], { }, and \

Sometimes square brackets ([ ]) are part of the command syntax. In these cases, you must either enclose the open and closed square brackets characters with curly brackets ({ }) or precede the open and closed square brackets ([ ]) characters with a backslash (\). If you do not, you will get an error message.

For example:

```
pin_assign -port {LFSR_OUT[0]} -pin 15
or
pin_assign -port LFSR_OUT\[0\] -pin 180
```

**Note:** Note: Tcl commands are case sensitive. However, their arguments are not.

## Entering Arguments on Separate Lines

To enter an argument on a separate line, you must enter a backslash (\) character at the end of the preceding line of the command as shown in the following example:

```
backannotate -dir \
{..\design} -name "fanouttest_ba.sdf" -format "SDF" -language "VERILOG" \
-netlist
```

### See Also

[Introduction to Tcl scripting](#)

[Basic syntax](#)

[About Designer Tcl commands](#)

# Project Manager Tcl Commands

## add\_file\_to\_library

Adds a file to a library in your project.

```
add_file_to_library
-library name
-file name
```

### Arguments

-library *name*

Name of the library where you wish to add your file.

-file *name*

Specifies the new name of the file you wish to add (must be a full pathname).

### Supported Families

All

### Exceptions

- None

### Example

Add a file named foo.vhd from the ./project/hdl directory to the library 'my\_lib'

```
add_file_to_library -library my_lib -file ./project/hdl/foo.vhd
```

### See Also

[add\\_library](#)

[remove\\_library](#)

[rename\\_library](#)

## add\_library

Adds a VHDL library to your project.

```
add_library
-library name
```

### Arguments

-library *name*

Specifies the name of your new library.

## Supported Families

All

## Exceptions

- None

## Example

Create a new library called 'my\_lib'.

```
add_library -library my_lib
```

### See Also

[remove\\_library](#)

[rename\\_library](#)

# add\_modelsim\_path

Adds a ModelSim simulation library to your project.

```
add_modelsim_path -lib library_name [-path library_path] [-remove " " ]
```

## Arguments

-lib *library\_name*

Name of the library you want to add.

-path *library\_path*

Path to library that you want to add.

-remove " "

Name of library you want to remove (if any).

## Supported Families

All

## Exceptions

None

## Example

Add the ModelSim library 'msim\_update2' located in the c:\modelsim\libraries directory and remove the library 'msim\_update1':

```
add_modelsim_path -lib msim_update2 [-path c:\modelsim\libraries] [-remove msim_update1]
```

# add\_profile

Sets the same values as the [Add or Edit Profile dialog box](#).

```
add_profile -name profilename -type value -tool profiletool -location tool_location [-args
tool_parameters] [-batch value]
```

## Arguments

-name *profilename*

Specifies the name of your new profile.

-type *value*

Specifies your profile type, where value is one of the following:

Value	Description
synthesis	New profile for a synthesis tool
simulation	New profile for a simulation tool
stimulus	New profile for a stimulus tool
flashpro	New FlashPro tool profile
coreconfig	New CoreConsole tool profile

-tool *profiletool*

Name of the tool you are adding to the profile.

-location *tool\_location*

Full pathname to the location of the tool you are adding to the profile.

-args *tool\_parameters*

Profile parameters (if any).

-batch *value*

Runs the tool in batch mode (if TRUE). Possible values are:

Value	Description
TRUE	Runs the profile in batch mode
FALSE	Does not run the profile in batch mode

## Supported Families

All

## Exceptions

None



## Example

Create a new FlashPro tool profile called 'myflashpro' linked to a FlashPro installation in my c:\programs\actel\flashpro\bin directory

```
new_profile -name myflashpro -type flashpro -tool flashpro.exe -location
c:\programs\actel\flashpro\bin\flashpro.exe -batch FALSE
```

## associate\_stimulus

Associates a stimulus file in your project.

```
-associate_stimulus
[-file name]*
[-mode value]
-module value
```

## Arguments

-file *name*

Specifies the name of the file to which you want to associate your stimulus files.

-mode *value*

Specifies whether you are creating a new stimulus association, adding, or removing; possible values are:

Value	Description
new	Creates a new stimulus file association
add	Adds a stimulus file to an existing association
remove	Removes an stimulus file association

-module *value*

Sets the module, where value is the name of the module.

## Supported Families

All

## Exceptions

None

## Example

The example associates a new stimulus file 'stim.vhd' for stimulus.

```
-associate_stimulus -file stim.vhd -mode new -module stimulus
```

## change\_link\_source

Changes the source of a linked file in your project.

```
change_link_source -file filename -path new_source_path
```

### Arguments

-file *filename*  
Name of the linked file you want to change.

-path *new\_source\_path*  
Location of the file you want to link to.

### Supported Families

All

### Exceptions

None

### Example

Change the link to a file 'sim1.vhd' in your project and link it to the file in c:\actel\link\_source\simulation\_test.vhd

```
change_link_source -file sim1.vhd -path c:\actel\link_source\simulation_test.vhd
```

## check\_hdl

Checks the HDL in the specified file.

```
check_hdl -file filename
```

### Arguments

-file *filename*  
Name of the HDL file you want to check.

### Supported Families

All

### Exceptions

None

### Example

Check HDL on the file hdl1.vhd.

```
check_hdl -file hdl1.vhd
```

## close\_project

Closes the current project in Libero IDE. Equivalent to clicking the File menu, and selecting Close Project.

```
close_project
```

### Arguments

None

### Supported Families

All

### Exceptions

- None

### Example

```
close_project
```

### See Also

[open\\_project](#)

## check\_schematic

Checks the schematic.

```
check_schematic -file filename
```

### Arguments

-file *filename*

Name of the schematic file you want to check.

### Supported Families

All

### Exceptions

None

### Example

Check schematic on the file schem.2vd.

```
check_schematic -file schem.2vd
```

## create\_links

Creates a link (or links) to a file/files in your project.

```
create_links [-hdl_source file]* [-stimulus file]* [-sdc file]* [-pin file]* [-dcf file]* [-gcf file]* [-pdc file]* [-crt file]* [-vcd file]*
```

### Arguments

`-hdl_source file`  
Name of the HDL file you want to link.

`-stimulus file`  
Name of the stimulus file you want to link.

`-sdc file`  
Name of the SDC file you want to link.

`-pin file`  
Name of the PIN file you want to link.

`-dcf file`  
Name of the DCF file you want to link.

`-gcf file`  
Name of the GCF file you want to link.

`-pdc file`  
Name of the PDC file you want to link.

`-crt file`  
Name of the crt file you want to link.

`-vcd file`  
Name of the VCD file you want to link.

### Supported Families

All

### Exceptions

None

### Example

Create a link to the file hdl1.vhd.

```
create links [-hdl_source hdl1.vhd]
```

## create\_symbol

Creates a symbol in a module.

```
create_symbol [-module module]
```

## Arguments

-module *module*  
Name of the symbol module you want to create.

## Supported Families

All

## Exceptions

None

## Example

Create a symbol named mod2.  

```
create_symbol [-module mod2]
```

## See Also

# delete\_files

Deletes files in your Libero IDE project.

```
delete_files  
-file value  
-from_disk
```

## Arguments

-file *value*  
Specifies the file you wish to delete from the project. This parameter is required for this Tcl command. It does not delete the file from the disk. Use the -from\_disk flag to delete a file from the disk. Value is the name of the file you wish to delete (including the full pathname).  
-from\_disk  
Deletes a file from the disk.

## Supported Families

All

## Exceptions

- None

## Example

Delete the files file1.vhd and file2.vhd from the project, and delete the file top\_palace.sdc from the disk.

```
delete_files -file ./project/hdl/file1.vhd -file ./project/hdl/file2.vhd
delete_files -from_disk -file ./project/phy_synthesis/top_palace.sdc
```

The following command deletes the core 'add1' from your disk and project (it is the same as the command to delete an IP core from your disk and project).

```
delete_files -from_disk -file ./project/component/work/add1/add1.cxf
```

## See Also

[close\\_project](#)

[new\\_project](#)

## edit\_profile

Sets the same values as the [Add or Edit Profile dialog box](#).

```
edit_profile -name profilename -type value -tool profiletool -location profilelocation [-args
parameters] [-batch value] [-new_name name]
```

## Arguments

-name *profilename*

Specifies the name of your new profile.

-type *value*

Specifies your profile type, where value is one of the following:

Value	Description
synthesis	New profile for a synthesis tool
simulation	New profile for a simulation tool
stimulus	New profile for a stimulus tool
flashpro	New FlashPro tool profile
coreconfig	New CoreConsole tool profile

-tool *profiletool*

Name of the tool you are adding to the profile.

-location *profilelocation*

Full pathname to the location of the tool you are adding to the profile.

-args *parameters*

Profile tool parameters (if any).

-batch *value*

Runs the tool in batch mode (if TRUE). Possible values are:

Value	Description
TRUE	Runs the profile in batch mode
FALSE	Does not run the profile in batch mode

-new\_name *name*  
 Name of new profile.

## Supported Families

All

## Exceptions

None

## Example

Edit a FlashPro tool profile called 'myflashpro' linked to a new FlashPro installation in my c:\programs\actel\flashpro\bin directory, change the name to updated\_flashpro.

```
edit_profile -name myflashpro -type flashpro -tool flashpro.exe -location
c:\programs\actel\flashpro\bin\flashpro.exe -batch FALSE -new_name updated_flashpro
```

## export\_as\_link

Exports a file to another directory and links to the file.

```
export_as_link -file filename -path link_path
```

## Arguments

-file *filename*  
 Name of the file you want to export as a link.  
 -path *link\_path*  
 Path of the link.

## Supported Families

All

## Exceptions

None

## Example

Export the file hdl1.vhd as a link to c:\actel\link\_source.

```
export_as_link -file hd11.vhd -path c:\actel\link_source
```

## export\_io\_constraints\_from\_adb

Exports the I/O constraints from your project ADB file to an output file.

```
export_io_constraints_from_adb -adb filename -output outputfilename
```

### Arguments

-adb *filename*

Specifies name of the ADB file from which you want to export your I/O constraints.

-output *filename*

Specifies the output filename for your exported I/O constraints.

### Supported Families

All

### Exceptions

None

### Example

The following example exports the I/O constraint file ios.pdc from the project file designer1.adb:

```
export_io_constraints_from_adb -adb designer1.adb -output ios.pdc
```

## export\_profiles

Exports your tool profiles. Performs the same action as the [Export Profiles dialog box](#).

```
export_profile -file name [-export value]
```

### Arguments

-file *name*

Specifies the name of your exported profile.

-export *value*

Specifies your profile export options. The following table shows the acceptable values for this argument:

Value	Description
predefined	Exports only predefined profiles
user	Exports only user profiles



Value	Description
all	Exports all profiles

## Supported Families

All

## Exceptions

None

## Example

The following command exports all profiles to the file 'all\_profiles':

```
export_profiles -file all_profiles [-export all]
```

## generate\_ba\_files

Generates the back-annotate files for your design.

```
generate_ba_files -adb filename
```

## Arguments

-adb *filename*

Specifies name of the ADB file from which you wish to generate the backannotate files.

## Supported Families

All

## Exceptions

None

## Example

The following example generates backa-nnotate files from the file designer1.adb:

```
generate_ba_files -adb designer1.adb
```

## generate\_hdl\_from\_schematic

Generates an HDL file from your schematic.

```
generate_hdl_from_schematic [-module modulename]
```

## Arguments

`-module modulename`  
Specifies the module name for your new HDL module

## Supported Families

All

## Exceptions

None

## Example

The following example generates a new HDL module `module1.vhd`:

```
generate_hdl_from_schematic [-module module1.vhd]
```

## generate\_hdl\_netlist

Generates the HDL netlist for your design and runs the design rule check.

```
generate_hdl_netlist [-netlist filename] [-run_drc value]
```

## Arguments

`-netlist filename`  
Specifies the filename of your netlist.

`-run_drc value`  
Runs the design rule check. The following table shows the acceptable values for this argument:

Value	Description
TRUE	Runs the design rule check
FALSE	Generates your netlist without running the design rule check

## Supported Families

All

## Exceptions

None

## Example

The following example generates your netlist `netlist2` and runs the design rule check:

```
generate_hdl_netlist [-netlist netlist2][-run_drc TRUE]
```

## import\_files (Liberio IDE)

The `import_files` command imports all the files you need in your Liberio IDE project.

```
import_files
-schematic {file}
-symbol {file}
-smartgen_core {file}
-ccp {file}
-stimulus {file}
-hdl_source {file}
-edif {file}
-sdc {file}
-pin {file}
-dcf {file}
-pdc {file}
-gcf {file}
-vcd {file}
-saif {file}
-crt {file}
-simulation {file}
-profiles {file}
-cxf {file}
-templates {file}
-ccz {file}
-wf_stimulus {file}
-modelsim_ini {file}
```

### Arguments

`-schematic {file}`

Specifies the schematics you wish to import into your IDE project. Type parameter must be repeated for each file.

`-symbol {file}`

Specifies the symbols you wish to import into your IDE project. Type parameter must be repeated for each file.

`-smartgen_core {file}`

Specifies the cores you wish to import into your project. Type parameter must be repeated for each file.

`-ccp {file}`

Specifies the ARM or Cortex-M1 cores you wish to import into your project. Type parameter must be repeated for each file.

`-stimulus {file}`

Specifies HDL stimulus files you wish to import into your project. Type parameter must be repeated for each file.

`-hdl_source {file}`

Specifies the HDL source files you wish to import into your project. Type parameter must be repeated for each file.

`-edif {file}`

Specifies the EDIF files you wish to import into your project. Type parameter must be repeated for each file.

`-constraint_sdc {file}`

Specifies the SDC constraint files you wish to import into your project. Type parameter must be repeated for each file.

`-constraint_pin {file}`

Specifies the PIN constraint files you wish to import into your project. Type parameter must be repeated for each file.

`-constraint_dcf {file}`

Specifies the DCF constraint files you wish to import into your project. Type parameter must be repeated for each file.

`-constraint_pdc {file}`

Specifies the PDC constraint files you wish to import into your project. Type parameter must be repeated for each file.

`-constraint_gcf {file}`

Specifies the GCF constraint files you wish to import into your project. Type parameter must be repeated for each file.

`-constraint_vcd {file}`

Specifies the VCD constraint files you wish to import into your project. Type parameter must be repeated for each file.

`-constraint_saif {file}`

Specifies the SAIF constraint files you wish to import into your project. Type parameter must be repeated for each file.

`-constraint_crt {file}`

Specifies the CRT constraint files you wish to import into your project. Type parameter must be repeated for each file.

`-simulation {file}`

Specifies the simulation files you wish to import into your Libero IDE project. Type parameter must be repeated for each file.

`-profiles {file}`

Specifies the profile files you wish to import into your Libero IDE project. Type parameter must be repeated for each file.

`-cxf {file}`

Specifies the CXF file (such as SmartDesign components) you wish to import into your Libero IDE project. Type parameter must be repeated for each file.

`-templates {file}`

Specifies the template file you wish to import into your IDE project.

`-ccz {file}`

Specifies the IP core file you wish to import into your project.

`-wf_stimulus {file}`

Specifies the WaveFormer Pro stimulus file you wish to import into your project.

`-modelsim_ini {file}`

Specifies the ModelSIM INI file that you wish to import into your project.

## Supported Families

All

## Exceptions

None

## Example

The command below imports the HDL source files file1.vhd and file2.vhd:

```
import_files -hdl_source file1.vhd -hdl_source file2.vhd
```

## new\_project

Creates a new project in the Libero IDE. If you do not specify a location, Libero IDE saves the new project in your current working directory.

```
new_project -name project_name -location project_location -family family_name -die device_die -
package package_name -hdl HDL_type
```

## Arguments

-name *project\_name*

The name of the project. This is used as the base name for most of the files generated from Libero IDE.

-location *project\_location*

The location of the project. Must not be an existing directory.

-family *family\_name*

The Actel device family for your targeted design.

-die *device\_die*

Die for your targeted design.

-package *package\_name*

Package for your targeted design.

-hdl *HDL\_type*

Sets the HDL type for your new project.

Value	Description
VHDL	Sets your new projects HDL type to VHDL
VERILOG	Sets your new projects to Verilog

## Supported Families

All

## Exceptions

None

## Example

Creates a new project in the directory `c:/netlists/test` named "project", with the HDL type VHDL for the ProASIC family.

```
new_project -location C:/Netlists/Test -name Project -hdl VHDL -family PA
```

## open\_project

Opens an existing Libero IDE project.

```
open_project project_name -do_backup_on_convert value -backup_file backup_filename
```

## Arguments

*project\_name*

Must include the complete path to the PRJ file. If you do not provide the full path, Libero IDE infers that you want to open the project from your current working directory.

`-do_backup_on_convert` *value*

Sets the option to backup your files if you open a project created in a previous version of Libero IDE.

Value	Description
TRUE	Creates a backup of your original project before opening
FALSE	Opens your project without creating a backup

`-backup_file` *backup\_filename*

Sets the name of your backup file (if you choose to `do_backup_on_convert`).

## Supported Families

All

## Exceptions

- None

## Example

Open `project.prj` from the `c:/netlists/test` directory.

```
open_project c:/netlists/test/project.prj
```

## See Also

[close\\_project](#)

[new\\_project](#)

[save\\_project](#)

## organize\_cdb

Enables you to organize the CDB files in your project.

```
organize_cdb -file name -module name
```

### Arguments

-file *name*

Specifies the name of the CDB file you intend to organize.

-module *name*

Identifies the name of the module to which you wish to add the CDB file.

### Supported Families

All

### Exceptions

None

### Example

Adds the file design2.cdb to the module design\_test.

```
organize_cdb -file design2.cdb -module design_test
```

## organize\_constraints

Organizes the constraint files in your project.

```
-organize_constraints
[-file name]*
[-mode value]
-designer_view name
-module value
-tool value
```

### Arguments

-file *name*

Specifies the name of the file to which you want to associate your stimulus files.

-mode *value*

Specifies whether you are creating a new stimulus association, adding, or removing; possible values are:

Value	Description
new	Creates a new stimulus file association

Value	Description
add	Adds a stimulus file to an existing association
remove	Removes an stimulus file association

`-designer_view` *name*

Sets the name of the Designer View in which you wish to add the constraint file, where name is the name of the view (such as impl1).

`-module` *value*

Sets the module, where value is the name of the module.

`-tool` *value*

Identifies the intended use for the file, possible values are:

Value	Description
synthesis	File to be used for synthesis
designer	File to be used in Designer
phsynth	File to be used in physical synthesis

## Supported Families

All

## Exceptions

None

## Example

The example adds the constraint file delta.vhd in the Designer View impl2 for the Designer tool.

```
-organize_constraints -file delta.vhd -mode new -designer_view impl2 -module constraint
-tool designer
```

## organize\_sources

Organizes the source files in your project.

## Arguments

```
-organize_sources
[-file name]*
```



```
[ -mode value ]
-module value
-tool value
[ -use_default value ]
```

## Arguments

-file *name*

Specifies the name of the file to which you want to associate your stimulus files.

-mode *value*

Specifies whether you are creating a new stimulus association, adding, or removing; possible values are:

Value	Description
new	Creates a new stimulus file association
add	Adds a stimulus file to an existing association
remove	Removes an stimulus file association

-module *value*

Sets the module, where *value* is the name of the module.

-tool *value*

Identifies the intended use for the file, possible values are:

Value	Description
synthesis	File to be used for synthesis
simulation	File to be used for simulation

-use\_default *value*

Uses the default values for synthesis or simulation; possible values are:

Value	Description
TRUE	Uses default values for synthesis or simulation.
FALSE	Uses user-defined values for synthesis or simulation

## Supported Families

All

## Exceptions

None

## Example

The example organizes a new stimulus file 'stim.vhd' using default settings.

```
-organize_sources -file stim.vhd -mode new -module stimulus -tool synthesis -use_default
TRUE
```

## project\_settings

Modifies project flow settings for your Libero IDE project.

```
project_settings [-hdl "VHDL | VERILOG"] [-auto_update_modelsim_ini "TRUE | FALSE"] [-
auto_update_viewdraw_ini "TRUE | FALSE"] [-block_mode "TRUE | FALSE"] [-
auto_generate_synth_hdl "TRUE | FALSE"] [-auto_run_drc "TRUE | FALSE"] [-
auto_generate_viewdraw_hdl "TRUE | FALSE"] [-auto_file_detection "TRUE | FALSE"]
```

## Arguments

`-hdl "VHDL | VERILOG"`

Sets your project HDL type.

`-auto_update_modelsim_ini "TRUE | FALSE"`

Sets your auto-update modelsim.ini file option. TRUE updates the file automatically.

`-auto_update_viewdraw_ini "TRUE | FALSE"`

Sets your auto-update viewdraw.ini file option. TRUE updates the file automatically.

`-block_mode "TRUE | FALSE"`

Puts the Project Manager in Block mode, enables you to create blocks in your project.

`-auto_generate_synth_hdl "TRUE | FALSE"`

Auto-generates your HDL file after synthesis (when set to TRUE).

`-auto_run_drc "TRUE | FALSE"`

Auto-runs the design rule check immediately after synthesis (when set to TRUE).

`-auto_generate_viewdraw_hdl "TRUE | FALSE"`

Auto-generates your HDL netlist after a Save & Check in ViewDraw (when set to TRUE).

`-auto_file_detection "TRUE | FALSE"`

Automatically detects when new files have been added to the Libero IDE project folder (when set to TRUE).

## Supported Families

All

## Exceptions

None

## Example

Set your project to VHDL, do not auto-update the ModelSim INI or ViewDraw INI files, auto-generate HDL after synthesis, and enable auto-detect for files.

```
project_settings [-hdl "VHDL"] [-auto_update_modelsini "FALSE"] [-  
auto_update_viewdraw_ini "FALSE"] [-block_mode "FALSE"] [-auto_generate_synth_hdl  
"TRUE"] [-auto_file_detection "TRUE"]
```

## refresh

Refreshes your project, updates the view and checks for updated links and files.

```
refresh .
```

## Supported Families

All

## Exceptions

None

## Example

```
refresh
```

## remove\_core

Removes a core from your project.

```
remove_core -name core_name
```

## Arguments

-name *core\_name*

Name of the core you want to remove.

## Supported Families

All

## Exceptions

None

## Example

Remove the core ip-beta2:

```
remove_core -name ip-beta2.ccz
```

## remove\_library

Removes a VHDL library from your project.

```
remove_library  
-library name
```

### Arguments

-library *name*

Specifies the name of the library you wish to remove.

### Supported Families

All

### Exceptions

- None

### Example

Remove (delete) a library called 'my\_lib'.

```
remove_library -library my_lib
```

### See Also

[add\\_library](#)

[rename\\_library](#)

## remove\_profile

Deletes a tool profile.

```
remove_profile -name profilename
```

### Arguments

-name *profilename*

Specifies the name of the profile you wish to delete.

### Supported Families

All

### Exceptions

None

### Example

The following command deletes the profile 'custom1':

```
remove_profile -name custom1
```

## rename\_library

Renames a VHDL library in your project.

```
rename_library  
-library name  
-name name
```

### Arguments

-library *name*

Identifies the current name of the library that you wish to rename.

-name *name*

Specifies the new name of the library.

### Supported Families

All

### Exceptions

- None

### Example

Rename a library from 'my\_lib' to 'test\_lib1'

```
rename_library -library my_lib -name test_lib1
```

### See Also

[add\\_library](#)

[remove\\_library](#)

## rollback\_constraints\_from\_adb

You can enter pin constraints from Project Manager by either using the text editor to add them to a PDC file or by using the I/O Attribute Editor..

Once you have imported I/O constraint files into Designer, you can modify the constraints with the MultiView Navigator. After modifying the constraints, you can import them back into Project Manager to replace the existing constraints.

When you use the Rollback Constraints feature, Project Manager opens the ADB file, exports the PDC file, and then replaces it with the specified PDC file.

```
rollback_constraints_from_adb -adb filename -output output_filename
```

## Arguments

`-adb filename`

Specifies the filename of the ADB file from which you want to rollback constraints.

`-output output_filename`

Name of the output constraints file.

## Supported Families

All

## Exceptions

None

## Example

The following example creates a rollback constraints PDC file called `rollback1.pdc` from the ADB file `designer1.adb`:

```
rollback_constraints_from_adb -file designer1.adb -output rollback1
```

## run\_designer

Runs Designer with compile and layout options (if selected).

```
run_designer [-logfile filename] [-script filename] [-append_commands commands] [-adb value]
[-compile value] [-layout value] [-export_ba value]
```

## Arguments

`-logfile filename`

Specifies the filename of your logfile.

`-script filename`

Appends any scripts you wish to add to add to the flow, where filename is the name of the script.

`-append_commands commands`

Appends commands (if any), where commands is the list of appended commands.

`-adb value`

Creates or opens your ADB file. The following table shows the acceptable values for this argument:

Value	Description
new	Creates a new ADB file
open	Opens an existing ADB file
default	Uses the default ADB file in your Libero IDE project

`-compile value`

Compiles your design. The following table shows the acceptable values for this argument:

Value	Description
TRUE	Runs compile
FALSE	Does not run compile, proceeds to the next command

-layout *value*

Runs layout on your design. The following table shows the acceptable values for this argument:

Value	Description
TRUE	Runs layout
FALSE	Does not run layout, proceeds to the next command

-export\_ba *value*

Exports back-annotate files for your design. The following table shows the acceptable values for this argument:

Value	Description
TRUE	Exports back-annotate files
FALSE	Does not export back-annotate files; proceeds to the next command

## Supported Families

All

## Exceptions

None

## Example

The following example creates a logfile named designerlog2 and runs compile and layout on the default ADB file created in your Libero IDE project:

```
run_designer [-logfile designerlog2] [-adb default] [-compile TRUE] [-layout TRUE]
```

## run\_drc

Runs the design rule check on your netlist and generates an HDL file.

```
run_drc [-netlist file] [-gen_hdl value]
```

## Arguments

`-netlist file`

Name of the netlist file you want the design rule check to evaluate.

`-gen_hdl value`

Generates an HDL file (if TRUE). The following table shows the acceptable values for this argument:

Value	Description
TRUE	Generates an HDL file for your design
FALSE	Does not generate an HDL file after the design rule check

## Supported Families

All

## Exceptions

None

## Example

Run the design rule check on the netlist named 'dsnr3' and generates the HDL file

```
run_drc [-netlist 'dsnr3'] [-gen_hdl TRUE]
```

## run\_simulation

Runs simulation on your project with your default simulation tool and creates a logfile.

```
run_simulation [-logfile "name"] [-wlf "name"] [-dofile "name"] [-refresh_lib "value"] [-state "value"]
```

## Arguments

`-logfile "name"`

Name of your simulation logfile.

`-wlf "name"`

Name of WLF file you wish to use; this command and the `-dofile` command are exclusive.

`-dofile "name"`

Name of DO file you wish to use; this command and the `-wlf` command are exclusive.

`-refresh_lib "value"`

Sets your library refresh option using one of the following values:

Value	Description
TRUE	Refreshes your simulation library



Value	Description
FALSE	Does not refresh your simulation library

-state "*value*"

Identifies which simulation you want to perform.

Value	Description
Pre_Synthesis	Runs pre-synthesis simulation
Post_Synthesis	Runs post-synthesis simulation
Post_Phy_Synthesis	Runs post-synthesis physical simulation
Post_Layout	Runs post-layout simulation

## Supported Families

All

## Exceptions

None

## Example

The following command runs post-layout simulation on your project using the DO file 'myfile.do', does not refresh the simulation library, and creates the logfile 'mylog.log':

```
run_simulation -logfile "Mylog.log" -dofile "Myfile.do" -refresh_lib "TRUE" -state
"Post_Layout"
```

### See Also

[run\\_synthesis](#)

## run\_synthesis

Runs synthesis on your project and creates a logfile.

```
run_synthesis [-logfile "name"] [-target "target file name"]
```

## Arguments

-logfile "*name*"

Name of your synthesis logfile.

-target "*target file name*"

Name of your synthesis target file.

## Supported Families

All

## Exceptions

None

## Example

Run synthesis on your project and create the logfile 'mysynlogfile', and creates the target file 'targfile'.

```
run_synthesis [-logfile "mysynlogfile"] [-target "targfile"]
```

### See Also

[run\\_simulation](#)

## save\_log

Saves your Libero IDE log file.

```
save_log -file value
```

## Arguments

-file *value*

Value is your name for the new log file.

## Supported Families

All

## Exceptions

- None

## Example

Save the log file file\_log.

```
save_log -file file_log
```

### See Also

[close\\_project](#)

[new\\_project](#)

## save\_project

The save\_project command saves the current project in Libero IDE.

```
save_project
```

## Arguments

None

## Supported Families

All

## Exceptions

None

## Example

Saves the project in your current working directory:

```
save_project
```

### See Also

[new\\_project](#)

[open\\_project](#)

## save\_project\_as

The `save_as_project` command saves the current project in Libero IDE with a different name and in a specified directory. You must specify a location with the `-location` parameter.

```
save_project_as
-name project_name
-location project_location
-files value
-designer_views value
-replace_links value
```

## Arguments

`-name project_name`

Specifies the name of your new project.

`-location project_location`

Must include the complete path of the PRJ file. If you do not provide the full path, Libero IDE infers that you want to save the project to your current working directory. This is a required parameter.

`-files value`

Specifies the files you want to copy into your new project.

Value	Description
all	Copies all your files into your new project

Value	Description
project	Copies only your Libero IDE project files into your new project
source	Copies only the source files into your new project
none	Copies none of the files into your new project; useful if you wish to manually copy only specific project files

`-designer_views` *value*

Specifies the Designer views you wish to copy into your new project.

Value	Description
all	Copies all your Designer views into your new project
current	Copies only your current Designer view files into your new project
none	Copies none of your views into your new project

`-replace_links` *value*

Specifies whether or not you want to update your file links in your new project.

Value	Description
true	Replaces (updates) the file links in your project during your save
false	Saves your project without updating the file links

## Supported Families

All

## Exceptions

None

## Example

Saves your current Libero IDE project as mydesign.prj in the c:/netlists/testprj/mydesign directory:

```
save_project_as -location c:/netlists/testprj/mydesign -name mydesign.prj
```

## See Also

[new\\_project](#)

[open\\_project](#)

[save\\_project](#)

## select\_profile

Selects a profile to use in your project.

```
select_profile -name profilename
```

### Arguments

-name *profilename*

Specifies the name of the profile you wish to use.

### Supported Families

All

### Exceptions

None

### Example

The following command selects the profile 'custom1':

```
select_profile -name custom1
```

## set\_actel\_lib\_options

The set\_actel\_lib\_options command sets your simulation library to default, or to another library (when you specify a path).

```
set_actel_lib_options -use_default_sim_path value -sim_path {path}
```

### Arguments

-use\_default\_sim\_path *value*

Possible values are:

Value	Description
TRUE	Uses the default simulation library.
FALSE	Disables the default simulation library; enables you to specify a different simulation library with the -sim_path {path} option.

-sim\_path {*path*}

Specifies the path to your simulation library.

## Supported Families

All

## Exceptions

None

## Example

Uses a simulation library in the directory `c:\sim_lib\test`.

```
set_actel_lib_options -use_default_sim_path FALSE -sim_path {c:\sim_lib\test}
```

## set\_device (Project Manager)

Sets your device family, die, and package in the Project Manager.

```
set_device [-family family] [-die die] [-package package].
```

## Arguments

-family *family*  
Sets device family.

-die *die*  
Sets device die.

-package *package*  
Sets device package.

## Supported Families

All

## Exceptions

None

## Example

Set your device to Fusion, your die to AFS600, and your package to 484 FBGA

```
set_device [-family fusion] [-die afs600] [-package "484 FBGA"]
```

## set\_modelsim\_options

Sets your ModelSim simulation options.

```
set_modelsim_options
[-use_automatic_do_file value]
[-user_do_file {path}]
[-sim_runtime {value}]
[-tb_module_name {value}]
```

```
[-tb_top_level_name {value}]
[-include_do_file value]
[-included_do_file {value}]
[-type {value}]
[-resolution {value}]
[-add_vsim_options {value}]
[-display_dut_wave value]
[-log_all_signals value]
[-do_file_args value]
[-dump_vcd "TRUE | FALSE"]
[-vcd_file "VCD file name"]
```

## Arguments

`-use_automatic_do_file value`

Uses an automatic.do file in your project. Possible values are:

Value	Description
TRUE	Uses the default automatic.do file in your project.
FALSE	Uses a different *.do file; use the other simulation options to specify it.

`-user_do_file {path}`

Specifies the location of your user-defined \*.do file.

`-sim_runtime {value}`

Sets your simulation runtime. Value is the number and unit of time, such as {1000ns}.

`-tb_module_name {value}`

Specifies your testbench module name, where value is the name.

`-tb_top_level_name {value}`

Sets the top-level instance name in the testbench, where value is the name.

`-include_do_file value`

Includes a \*.do file; possible values are:

Value	Description
TRUE	Includes the *.do file.
FALSE	Does not include the *.do file

`-included_do_file {value}`

Specifies the name of the included \*.do file, where value is the name of the file.

`-type {value}`

Resolution type; possible values are:

Value	Description
min	Minimum
typ	Typical
max	Maximum

-resolution {*value*}

Sets your resolution value, such as {1ps}.

-add\_vsim\_options {*value*}

Adds more Vsim options, where value specifies the option(s).

-display\_dut\_wave *value*

Enables ModelSim to display signals for the tested design; possible values are:

Value	Description
0	Displays the signal for the top_level_testbench
1	Enables ModelSim to display the signals for the tested design

-log\_all\_signals *value*

Enables you to log all your signals during simulation; possible values are:

Value	Description
TRUE	Logs all signals
FALSE	Does not log all signals

-do\_file\_args *value*

Specifies \*.do file command parameters.

-dump\_vcd *value*

Dumps the VCD file when simulation is complete; possible values are:

Value	Description
TRUE	Dumps the VCD file
FALSE	Does not dump the VCD file



`-vcd_file {value}`

Specifies the name of the dumped VCD file, where value is the name of the file.

## Supported Families

All

## Exceptions

None

## Example

Sets ModelSim options to use the automatic \*.do file, sets simulation runtime to 1000ns, sets the testbench module name to "testbench", sets the testbench top level to <top>\_0, sets simulation type to "max", resolution to 1ps, adds no vsim options, does not log signals, adds no additional DO file arguments, dumps the VCD file with a name power.vcd.

```
set_modelsim_options -use_automatic_do_file 1 -sim_runtime {1000ns} -tb_module_name
{testbench} -tb_top_level_name {<top>_0} -include_do_file 0 -type {max} -resolution
{1ps} -add_vsim_options {} -display_dut_wave 0 -log_all_signals 0 -do_file_args {} -
dump_vcd 0 -vcd_file {power.vcd}
```

## set\_option

Sets your synthesis options on a module.

```
set_option [-synth "TRUE | FALSE"] [-module module]
```

## Arguments

`-synth "TRUE | FALSE"`

Runs synthesis (for a value of TRUE).

`-module module`

Identifies the module on which you will run synthesis.

## Supported Families

All

## Exceptions

None

## Example

Run synthesis on the module test1.vhd:

```
set_option [-synth TRUE] [-module test1.vhd]
```

## set\_user\_lib\_options

Sets your user library options during simulation. If you do not use a custom library these options are not available.

```
set_user_lib_options
-name {value}
-path {path}
-option {value}
```

### Arguments

-name {value}

Sets the name of your user library.

-path {path}

Sets the pathname of your user library.

-option {value}

Sets your default compile options on your user library; possible values are:

Value	Description
do_not_compile	User library is not compiled
refresh	User library is refreshed
compile	User library is compiled
recompile	User library is recompiled
refresh_and_compile	User library is refreshed and compiled

### Supported Families

All

### Exceptions

None

### Example

The example below sets the name for the user library to "test1", the path to c:/actel\_des\_files/libraries/test1, and the compile option to "do not compile".

```
set_user_lib_options -name {test1} -path {c:/actel_des_files/libraries/test1} -option
{do_not_compile}
```

## set\_root

Sets the module you specify as the root.

```
set_root module_name
```

### Arguments

set\_root *module\_name*

Specifies the name the module you want to set as root.

### Supported Families

All

### Exceptions

None

### Example

Set the module mux8 as root:

```
set_root mux8
```

## synplify

Runs Synplify in batch mode and executes a Tcl script.

```
synplify -batch -licensetype synplify_acteloem <Tcl_script>.tcl
```

### Arguments

-batch

Runs Synplify in batch mode.

-licensetype synplify\_acteloem <Tcl\_script>.tcl

Runs Synplify and executes the Tcl script identified in the brackets; omit the brackets in the final script, as in the example below.

### Exceptions

None

### Example

The following example runs Synplify in batch mode and executes the Tcl script 'mytcl.tcl'.

```
synplify -batch -licensetype synplify_acteloem mytcl.tcl
```

## \_pro

Runs Synplify Pro in batch mode and executes a Tcl script.

```
synplify_pro -batch -licensetype synplifypro_acteloem <Tcl_script>.tcl
```

### Arguments

-batch

Runs Synplify Pro in batch mode.

-licensetype synplifypro\_acteloem <Tcl\_script>.tcl

Runs Synplify Pro and executes the Tcl script identified in the brackets; omit the brackets in the final script, as in the example below.

### Exceptions

None

### Example

The following example runs Synplify Pro in batch mode and executes the Tcl script 'mytcl.tcl':

```
synplify_pro -batch -licensetype synplifypro_acteloem mytcl.tcl
```

## unlink

Removes a link to a file in your project.

```
unlink -file filename [-local local_filename]
```

### Arguments

-file *filename*

Name of the linked (remote) file you want to unlink.

-local *local\_filename*

Name of the local file that you want to unlink.

### Supported Families

All

### Exceptions

None

## Example

Unlink the file hd11.vhd from my local file test.vhd

```
unlink -file hd11.vhd [-local test.vhd]
```

## use\_file

Specifies which file in your project to use.

```
use_file  
-file value  
-module value  
-designer_view value
```

## Arguments

-file *value*

Specifies the EDIF or ADB file you wish to use in the project. Value is the name of the file you wish use (including the full pathname).

-module *value*

Specifies the module in which you want to use the file.

-designer\_view *value*

Specifies the Designer View in which you wish to use the file.

## Supported Families

All

## Exceptions

- None

## Example

Specify file1.edn in the ./project/synthesis directory, in the module named top, in the Designer View named impl1.

```
use_file -file "./project/synthesis/file1.edn" -module "top" -designer_view "Impl1"
```

### See Also

[use\\_source\\_file](#)

## use\_source\_file

Defines a module for your project.

```
use_source_file  
-file value  
-module value
```

## Arguments

-file *value*

Specifies the Verilog or VHDL file. Value is the name of the file you wish use (including the full pathname).

-module *value*

Specifies the module in which you want to use the file.

## Supported Families

All

## Exceptions

None

## Example

Specify file1.vhd in the ./project/hdl directory, in the module named top.

```
use_source_file -file "./project/hdl/file1.vhd" -module "top"
```

### See Also

[use\\_file](#)

## About Designer Tcl commands

A Tcl (Tool Command Language) file contains scripts for simple or complex tasks. You can run scripts from either the Windows or UNIX command line or store and run a series of Tcl commands in a “.tcl” batch file. You can also run scripts from within Designer.

Designer supports the following Tcl scripting commands:

Command	Action
<a href="#">add_probe</a>	Adds a probe to an internal net in your design, using the original name from the optimized netlist in your design. Also, this command must be used in conjunction with the <a href="#">generate_probes</a> command to generate a probed ADB file (see example below).
<a href="#">all_inputs</a>	Returns an object representing all input and inout pins in the current design
<a href="#">all_outputs</a>	Returns an object representing all output and inout pins in the current design
<a href="#">all_registers</a>	Returns an object representing register pins or cells in the current scenario based on the given parameters
<a href="#">are_all_source_files_current</a>	Audits all source files and determines whether or not they are out of date / imported into the workspace

Command	Action
<a href="#">backannotate</a>	Extracts timing delays from your post layout data
<a href="#">check_timing_constraints</a>	Checks all timing constraints in the current timing scenario for validity
<a href="#">clone_scenario</a>	Creates a new timing scenario by duplicating an existing one
<a href="#">close_design</a>	Closes the current design
<a href="#">compile</a>	Performs design rule check and optimizes the input netlist before translating the source code into machine code
<a href="#">create_clock</a>	Creates a clock constraint on the specified ports/pins, or a virtual clock if no source is specified
<a href="#">create_generated_clock</a>	Creates an internally generated clock constraint on the ports/pins and defines its characteristics
<a href="#">create_scenario</a>	Creates a new timing scenario with the specified name
<a href="#">delete_probe</a>	Deletes a probe on nets in a probed ADB file
<a href="#">delete_scenario</a>	Deletes the specified timing scenario
<a href="#">export</a>	Converts a file from its current format into the specified file format, usually for use in another program
<a href="#">extended_run_shell</a>	Runs multiple iterations of layout through Designer
<a href="#">generate_probes</a>	Executes the probing and creates a new ADB file. This command is used in conjunction with the <a href="#">add_probe</a> Tcl command (see example below).
<a href="#">get_cells</a>	Returns an object representing the cells (instances) that match those specified in the pattern argument
<a href="#">get_clocks</a>	Returns an object representing the clock(s) that match those specified in the pattern argument in the current timing scenario
<a href="#">get_current_scenario</a>	Returns the name of the current timing scenario
<a href="#">get_defvar</a>	Returns the value of the Designer internal variable you specify

Command	Action
<a href="#">get_design_filename</a>	Returns the fully qualified path of the specified design file
<a href="#">get_design_info</a>	Returns detailed information about your design, depending on which arguments you specify
<a href="#">get_nets</a>	Returns an object representing the nets that match those specified in the pattern argument
<a href="#">get_out_of_date_files</a>	Audits all files returns a list of filenames that are out of date
<a href="#">get_pins</a>	Returns an object representing the pin(s) that match those specified in the pattern argument
<a href="#">get_ports</a>	Returns an object representing the port(s) that match those specified in the pattern argument
<a href="#">import_aux</a>	Imports the specified file as an auxiliary file, which are not audited and do not require you to re-compile the design
<a href="#">import_source</a>	Imports the specified file as a source file, which include your netlist and design constraints
<a href="#">ioadvisor_apply_suggestion</a>	Applies the suggestions for the selected attribute to the selected I/O(s)
<a href="#">ioadvisor_commit</a>	Saves all changes in the I/O Advisor
<a href="#">ioadvisor_restore</a>	Restores the I/O Advisor to the initial state
<a href="#">ioadvisor_restore_initial_value</a>	Sets the current value for the selected attribute and I/Os to the initial value
<a href="#">ioadvisor_set_outdrive</a>	Sets the outdrive for the selected I/Os
<a href="#">ioadvisor_set_outputload</a>	Sets the output load for the selected I/Os
<a href="#">ioadvisor_set_slew</a>	Sets the slew for the selected I/Os
<a href="#">is_design_loaded</a>	Returns True if the design is loaded into Designer; otherwise, returns False
<a href="#">is_design_modified</a>	Returns True if the design has been modified since it was last compiled; otherwise, returns False



Command	Action
<a href="#">is design state complete</a>	Returns True if the specified design state is complete (for example, you can inquire as to whether a die and package has been selected for the design); otherwise, returns False
<a href="#">is source file current</a>	Audits the source file and determines whether or not the file is out of date / imported into the workspace
<a href="#">layout</a>	Place-and-route your design
<a href="#">layout (advanced options for the SX family)</a>	Sets advanced place-and-route features for SX family designs
<a href="#">layout - Axcelerator</a>	Sets advanced place-and-route features for Axcelerator family designs
<a href="#">list clocks</a>	Returns details about all of the clock constraints in the current timing constraint scenario
<a href="#">list clock latencies</a>	Returns details about all of the clock latencies in the current timing constraint scenario
<a href="#">list clock uncertainties</a>	Returns the list of clock-to-clock uncertainty constraints for the current scenario.
<a href="#">list disable timings</a>	Returns the list of disable timing constraints for the current scenario
<a href="#">list false paths</a>	Returns details about all of the false paths in the current timing constraint scenario
<a href="#">list generated clocks</a>	Returns details about all of the generated clock constraints in the current timing constraint scenario
<a href="#">list input delays</a>	Returns details about all of the input delay constraints in the current timing constraint scenario
<a href="#">list max delays</a>	Returns details about all of the maximum delay constraints in the current timing constraint scenario
<a href="#">list min delays</a>	Returns details about all of the minimum delay constraints in the current timing constraint scenario
<a href="#">list multicycle paths</a>	Returns details about all of the multicycle paths in the current timing constraint

Command	Action
	scenario
<a href="#">list_objects</a>	Returns a list of names of the objects in the specified list
<a href="#">list_output_delays</a>	Returns details about all of the output delay constraints in the current timing constraint scenario
<a href="#">list_scenarios</a>	Returns a list of names of all of the available timing scenarios
<a href="#">new_design</a>	Creates a new design (.adb) file in a specific location for a particular design family such as Axcelerator or ProASIC3
<a href="#">open_design</a>	Opens an existing design in the Designer software
<a href="#">pin_assign</a>	Assigns the named pin to the specified port but does not lock its assignment.
<a href="#">pin_commit</a>	Saves the pin assignments to the design (.adb) file.
<a href="#">pin_fix</a>	Locks the pin assignment for the specified port, so the pin cannot be moved during place-and-route.
<a href="#">pin_fix_all</a>	Locks all the assigned pins on the device so they cannot be moved during place-and-route.
<a href="#">pin_unassign</a>	Unassigns a specific pin from a specific port. The unassigned pin location is then available for other ports.
<a href="#">pin_unassign_all</a>	Unassigns all pins from a specific port.
<a href="#">pin_unfix</a>	Unlocks the specified pin from its port.
<a href="#">layout (advanced options for ProASIC)</a>	Sets advanced place-and-route features for ProASIC family designs
<a href="#">remove_clock</a>	Removes the specified clock constraint from the current timing scenario
<a href="#">remove_clock_latency</a>	Removes a clock source latency from the specified clock and from all edges of the clock
<a href="#">remove_clock_uncertainty</a>	Removes a clock-to-clock uncertainty from the current timing scenario by specifying either its exact arguments or its ID

Command	Action
<a href="#">remove_disable_timing</a>	Removes a disable timing constraint by specifying its arguments, or its ID
<a href="#">remove_false_path</a>	Removes a false path from the current timing scenario by specifying either its exact arguments or its ID
<a href="#">remove_generated_clock</a>	Removes the specified generated clock constraint from the current scenario
<a href="#">remove_input_delay</a>	Removes an input delay a clock on a port by specifying both the clocks and port names or the ID of the input_delay constraint to remove
<a href="#">remove_max_delay</a>	Removes a maximum delay constraint in the current timing scenario by specifying either its exact arguments or its ID.
<a href="#">remove_min_delay</a>	Removes a minimum delay constraint in the current timing scenario by specifying either its exact arguments or its ID
<a href="#">remove_multicycle_path</a>	Removes a multicycle path constraint in the current timing scenario by specifying either its exact arguments or its ID
<a href="#">remove_output_delay</a>	Removes an output delay by specifying both the clocks and port names or the ID of the output_delay constraint to remove
<a href="#">rename_scenario</a>	Renames the specified timing scenario with the new name provided
<a href="#">report</a>	Generates the type of report you specify: Status, Timing, Timer Violations, Flip-flop, Power, Pin, or I/O Bank
<a href="#">report (Activity and Hazards Power Report)</a>	Reads a VCD file and reports transitions and hazards for each clock cycle of the VCD file.
<a href="#">report (Bottleneck) using SmartTime</a>	Creates a bottleneck report
<a href="#">report (Cycle Accurate Power Report)</a>	Reports a power waveform with one power value per clock period or half-period instead of an average power for the whole simulation
<a href="#">Report (Data History)</a>	Reports new features and enhancements, bug fixes and known issues for the current release that may impact the power consumption of the design
<a href="#">report (Datasheet) using SmartTime</a>	Creates a datasheet report

Command	Action
<a href="#">Report (Power)</a>	Creates a Power report, which enables you to determine if you have any power consumption problems in your design
<a href="#">Report (Power Scenario)</a>	Creates a scenario power report, which enables you to enter a duration for a sequence of previously defined power modes and calculate the average power consumption and the expected battery life for this sequence.
<a href="#">report (Timing) using SmartTime</a>	Creates a timing report
<a href="#">report (Timing violations) using SmartTime</a>	Creates a timing violations report
<a href="#">set clock latency</a>	Defines the delay between an external clock source and the definition pin of a clock within SmartTime
<a href="#">set clock uncertainty</a>	Specifies a clock-to-clock uncertainty and returns the ID of the created constraint if the command succeeded
<a href="#">set current scenario</a>	Specifies the timing scenario for the Timing Analyzer to use
<a href="#">save design</a>	Writes the design to the specified filename
<a href="#">set defvar</a>	Sets the value of the Designer internal variable you specify >
<a href="#">set design</a>	Specifies the design name, family and path in which Designer will process the design
<a href="#">set device</a>	Specifies the type of device and its parameters
<a href="#">set disable timing</a>	Disables timing arcs within a cell and returns the ID of the created constraint
<a href="#">set false path</a>	Identifies paths that are considered false and excluded from the timing analysis in the current timing scenario
<a href="#">set input delay</a>	Creates an input delay on a port list by defining the arrival time of an input relative to a clock in the current scenario
<a href="#">set max delay</a>	Specifies the maximum delay for the timing paths in the current scenario
<a href="#">set min delay</a>	Specifies the minimum delay for the timing paths in the current scenario

Command	Action
<a href="#">set_multicycle_path</a>	Defines a path that takes multiple clock cycles in the current scenario
<a href="#">set_output_delay</a>	Defines the output delay of an output relative to a clock in the current scenario
<a href="#">smartpower_add_new_custom_mode</a>	Creates a new custom mode
<a href="#">smartpower_add_new_scenario</a>	Creates a new scenario
<a href="#">smartpower_add_pin_in_domain</a>	Adds a pin to either a Clock or Set domain
<a href="#">smartpower_change_clock_statistics</a>	Changes the default frequencies and probabilities for a specific domain
<a href="#">smartpower_change_setofpin_statistics</a>	Changes the default frequencies and probabilities for a specific set
<a href="#">smartpower_commit</a>	Saves the changes made in SmartPower to the design file (.adb) in Designer
<a href="#">smartpower_create_domain</a>	Creates a new clock or set domain
<a href="#">smartpower_edit_custom_mode</a>	Edits a custom mode
<a href="#">smartpower_edit_scenario</a>	Edits a scenario
<a href="#">smartpower_initialize_clock_with_constraints</a>	Initializes the clock frequency and the data frequency of a single clock domain with a specified clock name and the initialization options
<a href="#">smartpower_init_do</a>	Initializes the frequencies and probabilities for clocks, registers, set/reset nets, primary inputs, combinational outputs, enables and other sets of pins, and selects a mode for initialization
<a href="#">smartpower_init_set_clocks_options</a>	Initializes the clock frequency of all clock domains
<a href="#">smartpower_init_set_combinational_options</a>	Initializes the frequency and probability of all combinational outputs
<a href="#">smartpower_init_set_enables_options</a>	Initializes the clock frequency of all enable clocks with the initialization options
<a href="#">smartpower_init_set_thersets_options</a>	Initializes the frequency and probability of all other sets
<a href="#">smartpower_init_set_primaryinputs_options</a>	Initializes the frequency and probability of all primary inputs
<a href="#">smartpower_init_set_registers_options</a>	Initializes the frequency and probability of all register outputs

Command	Action
<a href="#">smartpower init set set reset options</a>	Initializes the frequency and probability of all set/reset nets
<a href="#">smartpower init setofpins values</a>	Initializes the frequency and probability of all sets of pins
<a href="#">smartpower remove all annotations</a>	Removes all initialization annotations for the specified mode
<a href="#">smartpower remove custom mode</a>	Removes a custom mode
<a href="#">smartpower remove domain</a>	Removes an existing domain
<a href="#">smartpower remove file</a>	Removes a VCD file from the specified mode
<a href="#">smartpower remove pin enable rate</a>	This command is obsolete and it is replaced by <a href="#">smartpower remove pin probability</a>
<a href="#">smartpower remove pin frequency</a>	Removes the frequency of an existing pin
<a href="#">smartpower remove pin of domain</a>	Removes a clock pin or a data pin from a Clock or Set domain, respectively.
<a href="#">smartpower remove pin probability</a>	Enables you to annotate the probability of a pin driving an enable pin
<a href="#">smartpower remove scenario</a>	Removes a scenario from the current design
<a href="#">smartpower remove vcd</a>	Removes an existing VCD file from a mode or entire design
<a href="#">smartpower restore</a>	Restores previously committed constraints
<a href="#">smartpower set battery capacity</a>	Sets the battery capacity
<a href="#">smartpower set cooling</a>	Sets the cooling style to one of the predefined types, or a custom value
<a href="#">smartpower set mode for analysis</a>	Sets the mode for cycle-accurate power analysis
<a href="#">smartpower set operating condition</a>	Sets the operating conditions used in SmartPower to best, typical, or worst case
<a href="#">smartpower set pin enable rate</a>	This command is obsolete and it is now replaced by <a href="#">smartpower set pin probability</a>
<a href="#">smartpower set pin frequency</a>	Sets the frequency of an existing pin
<a href="#">smartpower set pin probability</a>	Enables you to annotate the probability of a pin driving an enable pin

Command	Action
<a href="#">smartpower set preferences</a>	Sets SmartPower preferences such as power unit, frequency unit, operating mode, operating conditions, and toggle
<a href="#">smartpower set scenario for analysis</a>	Sets the scenario for cycle-accurate power analysis
<a href="#">smartpower set temperature opcond</a>	Sets the temperature in the operating conditions used in SmartPower
<a href="#">smartpower set thermalmode</a>	Sets the mode of computing junction temperature
<a href="#">smartpower set voltage opcond</a>	Sets the voltage in the operating conditions used in SmartPower
<a href="#">smartpower temperature opcond set design wide</a>	Sets the temperature for SmartPower design-wide operating conditions
<a href="#">smartpower temperature opcond set mode specific</a>	Sets the temperature for SmartPower mode-specific operating conditions
<a href="#">smartpower voltage opcond set design wide</a>	Sets the voltage settings for SmartPower design-wide operating conditions
<a href="#">smartpower voltage opcond set mode specific</a>	Sets the voltage settings for SmartPower mode-specific use operating conditions
<a href="#">st create set</a>	Creates a set of paths to be analyzed
<a href="#">st commit</a>	Saves the changes made in SmartTime to the design (.adb) file
<a href="#">st edit set</a>	Modifies the paths in a user set
<a href="#">st expand path</a>	Displays expanded path information (path details) for paths
<a href="#">st list paths</a>	Displays the list of paths in the same tabular format shown in SmartTime
<a href="#">st remove set</a>	Deletes a user set from the design
<a href="#">st restore</a>	Restores constraints previously committed in SmartTime
<a href="#">st set options</a>	Sets options for timing analysis
<a href="#">timer add clock exception</a>	Adds an exception to or from a pin with respect to a specified clock
<a href="#">timer add pass</a>	Adds the pin to the list of pins for which the path must be shown passing through in the timer
<a href="#">timer add stop</a>	Adds the specified pin to the list of pins through which the paths will not be

Command	Action
	displayed in the timer
<a href="#">timer_commit</a>	Saves the changes made to constraints in Timer into the Designer database.
<a href="#">timer_get_path</a>	Displays the Timer path information in the Log window
<a href="#">timer_get_clock_actuals</a>	Displays the actual clock frequency in the Log window
<a href="#">timer_get_clock_constraints</a>	Displays the clock constraints (period/frequency and dutycycle) in the Log window
<a href="#">timer_get_maxdelay</a>	Displays the maximum delay constraint between two pins of a path in the Log window
<a href="#">timer_get_path_constraints</a>	Displays the path constraints set for maxdelay in the Timer in the Log window
<a href="#">timer_remove_clock_exception</a>	Removes the previously set clock constraint
<a href="#">timer_remove_pass</a>	Removes the previously entered path pass constraint
<a href="#">timer_remove_stop</a>	Removes the path stop constraint on the specified pin
<a href="#">timer_restore</a>	Restores previously committed constraints
<a href="#">timer_setenv_clock_freq</a>	Sets a required clock frequency, in MHz, for the specified clock
<a href="#">timer_setenv_clock_period</a>	Sets the clock period constraint for the specified clock
<a href="#">timer_set_maxdelay</a>	Adds a maximum delay constraint for the path
<a href="#">timer_remove_all_constraints</a>	Removes all the timing constraints previously entered in the Designer system

Note: Note: Tcl commands are case sensitive. However, their arguments are not.

### See Also

[Introduction to Tcl scripting](#)

[Basic syntax](#)

## Tcl command documentation conventions

The following table shows the typographical conventions used for the Tcl command syntax.



Syntax Notation	Description
command - argument	Commands and arguments appear in Courier New typeface.
<i>variable</i>	<i>Variables appear in blue, italic Courier New typeface. You must substitute an appropriate value for the variable.</i>
[-argument <i>value</i> ] [ <i>variable</i> ]+	Optional arguments begin and end with a square bracket with one exception: if the square bracket is followed by a plus sign (+), then users must specify at least one argument. The plus sign (+) indicates that items within the square brackets can be repeated. Do not enter the plus sign character.

**Note:** Note: All Tcl commands are case sensitive. However, their arguments are not.

## Examples

Syntax for the get\_defvar command followed by a sample command:

```
get_defvar variable
```

```
get_defvar "DESIGN"
```

Syntax for the backannotate command followed by a sample command:

```
backannotate -name file_name -format format_type -language language -dir directory_name [-netlist] [-pin]
```

```
backannotate -dir \  
{..\design} -name "fanouttest_ba.sdf" -format "SDF" -language "VERILOG" \  
-netlist
```

## Wildcard Characters

You can use the following wildcard characters in names used in Tcl commands:

Wildcard	What it Does
\	Interprets the next character literally
?	Matches any single character
*	Matches any string
[]	Matches any single character among those listed between brackets (that is, [A-Z] matches any single character in the A-to-Z range)

**Note:** Note: The matching function requires that you add a slash (\) before each slash in the port, instance, or net name when using wildcards in a PDC command and when using wildcards in the Find feature of the MultiView Navigator. For example, if you have an instance named “A/B12” in the netlist, and you enter that name as “A\\B\*” in a PDC command, you will not be able to find it. In this case, you must specify the name as A\\VB\*.

## Special Characters [ ], { }, and \

Sometimes square brackets ([ ]) are part of the command syntax. In these cases, you must either enclose the open and closed square brackets characters with curly brackets ({} ) or precede the open and closed square brackets ([ ]) characters with a backslash (\). If you do not, you will get an error message.

For example:

```
pin_assign -port {LFSR_OUT[0]} -pin 15
or
pin_assign -port LFSR_OUT\[0\] -pin 180
```

**Note:** Note: Tcl commands are case sensitive. However, their arguments are not.

## Entering Arguments on Separate Lines

To enter an argument on a separate line, you must enter a backslash (\) character at the end of the preceding line of the command as shown in the following example:

```
backannotate -dir \
{..\design} -name "fanouttest_ba.sdf" -format "SDF" -language "VERILOG" \
-netlist
```

### See Also

[Introduction to Tcl scripting](#)

[Basic syntax](#)

[About Designer Tcl commands](#)

## add\_probe

Adds a probe to an internal net in your design, using the original name from the optimized netlist in your design. Also, this command must be used in conjunction with the [generate\\_probes](#) command to generate a probed ADB file (see example below).

You must complete layout before you use this command.

```
add_probe -net <net_name> [-pin <pin_name>] [-port <port_name>] [-assign_to_used_pin
<TRUE|FALSE>]
```

## Arguments

-net <net\_name>

Name of the net you want to probe. You cannot probe HARDWIRED, POWER, or INTRINSIC nets.

`-pin <pin_name>`

Name of the package pin at which you want to put the net to be probed. Argument is optional; if unspecified the net is routed to any free package pin.

`-port <port_name>`

Name of the port you are adding. Argument is optional; if unspecified the default value is PROBE\_<n>.

`-assign_to_used_pin <TRUE/FALSE>`

Probes a net on an already used pin. The net on the existing pin will be disconnected. Argument is optional; if unspecified the net can be only routed on unused pin.

## Supported Families

IGLOO, ProASIC3, SmartFusion and Fusion

## Exceptions

None

## Example

The example below adds a probe to the net Count8\_0/INV\_0\_Y on pin 7 and uses the port name PROBE\_1, then generates the probe ADB file named test1.adb.

Note that generate\_probes is a separate Tcl command.

```
add_probe -net Count8_0/INV_0_Y -assign_to_used_pin {FALSE} -pin {7} -port {PROBE_1}
generate_probes -save test1.adb
```

## See Also

[delete\\_probe](#)

[generate\\_probes](#)

[Generating a Probed Design](#)

[Generate Probed Design - Add Probe\(s\) Dialog Box](#)

## all\_inputs

Returns an object representing all input and inout pins in the current design.

```
all_inputs
```

## Arguments

None

## Supported Families

IGLOO, ProASIC3, SmartFusion, Fusion, ProASIC<sup>PLUS</sup>, ProASIC, Axcelerator, RTAX-S, eX, and SX-A

## Exceptions

You can only use this command as part of a `-from`, `-to`, or `-through` argument in the following Tcl commands:

[set\\_min\\_delay](#), [set\\_max\\_delay](#), [set\\_multicycle\\_path](#), and [set\\_false\\_path](#).

## Examples

```
set_max_delay -from [all_inputs] -to [get_clocks ck1]
```

### See Also

[Tcl documentation conventions](#)

## all\_outputs

Returns an object representing all output and inout pins in the current design.

```
all_outputs
```

## Arguments

None

## Supported Families

IGLOO, ProASIC3, SmartFusion, Fusion, ProASIC<sup>PLUS</sup>, ProASIC, Axcelerator, RTAX-S, eX, and SX-A

## Exceptions

You can only use this command as part of a `-from`, `-to`, or `-through` argument in the following Tcl commands:

[set\\_min\\_delay](#), [set\\_max\\_delay](#), [set\\_multicycle\\_path](#), and [set\\_false\\_path](#).

## Examples

```
set_max_delay -from [all_inputs] -to [all_outputs]
```

### See Also

[Tcl documentation conventions](#)

## all\_registers

Returns an object representing register pins or cells in the current scenario based on the given parameters.

```
all_registers [-clock clock_name]  
[-async_pins][-output_pins][-data_pins][-clock_pins]
```

## Arguments

`-clock` *clock\_name*

Specifies the name of the clock domain to which the registers belong. If no clock is specified, all registers in the design will be targeted.

-async\_pins

Lists all register pins that are async pins for the specified clock (or all registers asynchronous pins in the design).

-output\_pins

Lists all register pins that are output pins for the specified clock (or all registers output pins in the design).

-data\_pins

Lists all register pins that are data pins for the specified clock (or all registers data pins in the design).

-clock\_pins

Lists all register pins that are data pins for the specified clock (or all registers clock pins in the design).

## Supported Families

IGLOO, ProASIC3, SmartFusion, Fusion, ProASIC<sup>PLUS</sup>, ProASIC, Axcelerator, RTAX-S, eX, and SX-A

## Exceptions

You can only use this command as part of a `-from`, `-to`, or `-through` argument in the following Tcl commands:

[set\\_min\\_delay](#), [set\\_max\\_delay](#), [set\\_multicycle\\_path](#), and [set\\_false\\_path](#).

## Examples

```
set_max_delay 2.000 -from { ff_m:CLK ff_s2:CLK } -to [all_registers -clock_pins -clock {
ff_m:Q }]
```

## See Also

[Tcl documentation conventions](#)

# are\_all\_source\_files\_current

Audits all source files and determines whether or not they are out of date / imported into the workspace. Returns '1' if all source files are current Returns '0' if all source files are not current This command ignores the Audit settings in your ADB file.

```
are_all_source_files_current
```

## Arguments

None

## Supported Family

All

## Exceptions

- The command will return an error if arguments are passed.

## Example

The following code will determine if your source files are current.

```
are_all_source_files_current
```

### See Also

[get\\_out\\_of\\_date\\_files](#)

[is\\_source\\_file\\_current](#)

## backannotate

Equivalent to executing the Back-Annotate command from the Tools menu. You can export an SDF file, after layout, along with the corresponding netlist in the VHDL or Verilog format. These files are useful in backannotated timing simulation.

Actel recommends that you export both SDF and the corresponding VHDL/Verilog files. This will avoid name conflicts in the simulation tool.

Designer must have completed layout before this command can be invoked, otherwise the command will fail.

```
backannotate -name file_name -format format_type -language language -dir directory_name [-netlist] [-pin]
```

## Arguments

-name *file\_name*

Use a valid file name with this option. You can attach the file extension .sdf to the File\_Name, otherwise the tool will append .sdf for you.

-format *format\_type*

Only SDF format is available for back annotation

-language *language*

The supported Language options are:

Value	Description
VHDL93	For VHDL-93 style naming in SDF
VERILOG	For Verilog style naming in SDF

-dir *directory\_name*

Specify the directory in which all the files will be extracted.

-netlist

Forces a netlist to be written. The netlist will be either in Verilog or VHDL.

-pin

Designer exports the pin file with this option. The .pin file extension is appended to the design name to create the pin file.

## Supported Families

All

## Exceptions

- The `-pin` argument is not supported for ProASIC and ProASICPLUS families.

## Examples

Example 1:

```
backannotate
```

Uses default arguments and exports SDF file for back annotation

Example 2:

```
backannotate -dir \  
  {..\my_design_dir} -name "fanouttest_ba.sdf" -format "SDF" -language \ "VHDL93" -  
  netlist
```

This example uses some of the options for VHDL

Example 3:

```
backannotate -dir \  
  {..\design} -name "fanouttest_ba.sdf" -format "SDF" -language "VERILOG" \  
  -netlist
```

This example uses some of the options for Verilog

Example 4:

```
If { [catch { backannotate -name "fanouttest_ba" -format "SDF" } ]} {  
    Puts "Back annotation failed"  
    # Handle Failure  
}  
else {  
    Puts "Back annotation successful"  
    # Proceed with other operations  
}
```

You can catch exceptions and respond based on the success of backannotate operation

## See Also

[Tcl command documentation conventions](#)

# check\_timing\_constraints

Checks all timing constraints in the current timing scenario for validity.

```
check_timing_constraints
```

## Arguments

None

## Supported Families

IGLOO, ProASIC3, SmartFusion, Fusion, ProASIC<sup>PLUS</sup>, ProASIC, Axcelerator, RTAX-S, eX, and SX-A

## Exceptions

None

## Examples

```
check_timing_constraints
```

### See Also

[Tcl documentation conventions](#)

## clone\_scenario

Creates a new timing scenario by duplicating an existing one. You must provide a unique name (that is, it cannot already be used by another timing scenario).

```
clone_scenario name -source origin
```

## Arguments

*name*

Specifies the name of the new timing scenario to create.

-source *origin*

Specifies the source of the timing scenario to clone (copy). The source must be a valid, existing timing scenario.

## Supported Families

IGLOO, ProASIC3, SmartFusion, Fusion, Axcelerator, and RTAX-S

## Description

This command creates a timing scenario with the specified name, which includes a copy of all constraints in the original scenario (specified with the -source parameter). The new scenario is then added to the list of scenarios.

## Example

```
clone_scenario scenario_A -source {Primary}
```

### See Also

[create\\_scenario](#)

[delete\\_scenario](#)

[Tcl documentation conventions](#)



## close\_design

Closes the current design and brings Designer to a fresh state to work on a new design. This is equivalent to selecting the Close command from the File menu.

```
close_design
```

### Arguments

None

### Supported Families

All

### Exceptions

- None

### Example

```
if { [catch { close_design }] } {  
    puts "Failed to close design"  
    # Handle Failure  
} else {  
    puts "Design closed successfully"  
    # Proceed with processing a new design  
}
```

### See Also

[open\\_design](#)  
[close\\_design](#)  
[new\\_design](#)

## compile

Performs design rule check on the input netlist. Compile also performs some optimizations on the design through logic combining and buffer tree modifications. Compile options vary by family.

### Supported Families

- [MX, SX, SX-A, and eX](#)
- [Axcelerator](#)
- [ProASIC, ProASICPLUS](#)
- [IGLOO, ProASIC3, SmartFusion and Fusion](#)

## See Also

[Setting Compile Options](#)

# create\_clock

Creates a clock constraint on the specified ports/pins, or a virtual clock if no source other than a name is specified.

```
create_clock -period period_value [-name clock_name]  
[-waveform> edge_list] [source_objects]
```

## Arguments

-period *period\_value*

Specifies the clock period in nanoseconds. The value you specify is the minimum time over which the clock waveform repeats. The period\_value must be greater than zero.

-name *clock\_name*

Specifies the name of the clock constraint. You must specify either a clock name or a source.

-waveform *edge\_list*

Specifies the rise and fall times of the clock waveform in ns over a complete clock period. There must be exactly two transitions in the list, a rising transition followed by a falling transition. You can define a clock starting with a falling edge by providing an edge list where fall time is less than rise time. If you do not specify -waveform option, the tool creates a default waveform, with a rising edge at instant 0.0 ns and a falling edge at instant (period\_value/2)ns.

*source\_objects*

Specifies the source of the clock constraint. The source can be ports, pins, or nets in the design. If you specify a clock constraint on a pin that already has a clock, the new clock replaces the existing one. You must specify either a source or a clock name.

## Supported Families

IGLOO, ProASIC3, SmartFusion, Fusion, ProASIC<sup>PLUS</sup>, ProASIC (for analysis), Axcelerator, RTAX-S,eX, and SX-A

## Description

Creates a clock in the current design at the declared source and defines its period and waveform. The static timing analysis tool uses this information to propagate the waveform across the clock network to the clock pins of all sequential elements driven by this clock source.

The clock information is also used to compute the slacks in the specified clock domain that drive optimization tools such as place-and-route.

## Exceptions

- None

## Examples

The following example creates two clocks on ports CK1 and CK2 with a period of 6, a rising edge at 0, and a falling edge at 3:

```
create_clock -name {my_user_clock} -period 6 CK1
create_clock -name {my_other_user_clock} -period 6 -waveform {0 3} {CK2}
```

The following example creates a clock on port CK3 with a period of 7, a rising edge at 2, and a falling edge at 4:

```
create_clock -period 7 -waveform {2 4} [get_ports {CK3}]
```

## See Also

[create\\_generated\\_clock](#)

[Tcl Command Documentation Conventions](#)

# create\_generated\_clock

Creates an internally generated clock constraint on the ports/pins and defines its characteristics.

```
create_generated_clock [-name name] -source reference_pin [-divide_by divide_factor] [-
multiply_by multiply_factor] [-invert] source
```

## Arguments

`-name` *name*

Specifies the name of the clock constraint.

`-source` *reference\_pin*

Specifies the reference pin in the design from which the clock waveform is to be derived.

`-divide_by` *divide\_factor*

Specifies the frequency division factor. For instance if the *divide\_factor* is equal to 2, the generated clock period is twice the reference clock period.

`-multiply_by` *multiply\_factor*

Specifies the frequency multiplication factor. For instance if the *multiply\_factor* is equal to 2, the generated clock period is half the reference clock period.

`-invert`

Specifies that the generated clock waveform is inverted with respect to the reference clock.

*source*

Specifies the source of the clock constraint on internal pins of the design. If you specify a clock constraint on a pin that already has a clock, the new clock replaces the existing clock. Only one source is accepted. Wildcards are accepted as long as the resolution shows one pin.

## Supported Families

IGLOO, ProASIC3, SmartFusion, Fusion, ProASIC<sup>PLUS</sup>, ProASIC (for analysis), Axcelerator, RTAX-S,eX, and SX-A

## Description

Creates a generated clock in the current design at a declared source by defining its frequency with respect to the frequency at the reference pin. The static timing analysis tool uses this information to compute and propagate its waveform across the clock network to the clock pins of all sequential elements driven by this source.

The generated clock information is also used to compute the slacks in the specified clock domain that drive optimization tools such as place-and-route.

## Examples

The following example creates a generated clock on pin U1/reg1:Q with a period twice as long as the period at the reference port CLK.

```
create_generated_clock -name {my_user_clock} -divide_by 2 -source [get_ports {CLK}]  
U1/reg1:Q
```

The following example creates a generated clock at the primary output of myPLL with a period  $\frac{3}{4}$  of the period at the reference pin clk.

```
create_generated_clock -divide_by 3 -multiply_by 4 -source clk [get_pins {myPLL:CLK1}]
```

### See Also

[create\\_clock](#)

[Tcl Command Documentation Conventions](#)

## create\_scenario

Creates a new timing scenario with the specified name. You must provide a unique name (that is, it cannot already be used by another timing scenario).

```
create_scenario name
```

## Arguments

*name*

Specifies the name of the new timing scenario.

## Supported Families

IGLOO, ProASIC3, SmartFusion, Fusion, Axcelerator, and RTAX-S

## Description

A timing scenario is a set of timing constraints used with a design. Scenarios enable you to easily refine the set of timing constraints used for Timing-Driven Place-and-Route, so as to achieve timing closure more rapidly.

This command creates an empty timing scenario with the specified name and adds it to the list of scenarios.

## Exceptions

- None

## Example

```
create_scenario scenario_A
```

### See Also

[clone\\_scenario](#)

[Tcl Command Documentation Conventions](#)

## delete\_probe

Deletes a probe on nets in a probed ADB file.

```
delete_probe -net <net_name>
```

## Arguments

-net <net\_name>

Name of the net you want to delete.

## Supported Families

IGLOO, ProASIC3, SmartFusion and Fusion

## Exceptions

None

## Example

The example below deletes the probe on the net Count8\_0/INV\_0\_Y.

```
delete_probe -net Count8_0/INV_0_Y
```

### See Also

[add\\_probe](#)

[Generating a Probed Design](#)

[Generate Probed Design - Add Probe\(s\) Dialog Box\\_Ref2104634540](#)

## delete\_scenario

Deletes the specified timing scenario.

```
delete_scenario name
```

## Arguments

*name*

Specifies the name of the timing scenario to delete.

## Supported Families

IGLOO, ProASIC3, SmartFusion, Fusion, Axcelerator, and RTAX-S

## Description

This command deletes the specified timing scenario and all the constraints it contains.

## Exceptions

- At least one timing scenario must always be available. If the current scenario is the only one that exists, you cannot delete it.
- Scenarios that are linked to the timing analysis or layout cannot be deleted.

## Example

```
delete_scenario scenario_A
```

### See Also

[create\\_scenario](#)

[Tcl Command Documentation Conventions](#)

## export

The syntax and arguments for the **export** command vary depending on which device you are designing. Click the appropriate command in the following list to see the syntax, arguments, and other information:

- [export](#) (IGLOO, ProASIC3, SmartFusion and Fusion)
- [export](#) (ProASIC<sup>PLUS</sup>, ProASIC, Axcelerator, MX, eX, and SX/SX-A)
- [export](#) (Block support for IGLOO, ProASIC3, SmartFusion, Fusion, Axcelerator, and RTAX-S)

## export (IGLOO, ProASIC3, SmartFusion and Fusion)

Saves your design to a file in the specified file format. The required and optional arguments this command takes depends on which file format you specify.

```
export
[-format value]
[-feature value]
[-secured_device value]
[-signature value]
[-pass_key value]
[-aes_key value]
```

```

[-from_config_file value]
[-number_of_devices value]
[-from_progfile_type value]
[-target_programmer value]
[-custom_security value]
[-fpga_security_level value]
[-from_security_level value]
[-security_permanent value]{filename}
[-from_program_pages value]
[-from_content value]
[-set_io_state value]
[-efm_block_security {location:X;security_level: value}]
[-efm_content {location:X;source:value}]
[-efm_block {location:X;config_file:{value}}]
[-efm_client {location:X;client: value;mem_file: value}]

```

## Arguments

-format *value*

Specifies the file format of the file to export. The exported files vary from one device family to another; see the [Export help topic](#) for a description of each file type and the list of supported families.

You can export the files listed in the table below using the value.

File Types	Value
Netlist Files	adl
	afl
	edn
	v
	vhd
Constraint Files	crt
	dcf
	gcf
	sdc
	pdc
	pin
Programming Files	afm

File Types	Value
	bit
	bts_stp
	dat
	fus
	isc
	pdb
	1532
	svf
FlashPro Data File	fdb
Debugging Files	bsd
	prb
Timing Files	mod
	sdf
	stf
	tcl
Script Files	tcl
Log Files	log
IBIS Files	ibs
Other Files	cob
	loc
	seg



File Types	Value
Block Files	cdb
	cxp
	v
	vhd

`-feature {value}`

Select the silicon feature(s) you want to program. Possible values for this option are listed in the table below, or the instance-specific program options available only for specific families (as shown in the table below). Actel recommends that you specify your program parameters for each Embedded Flash Memory Block (EFMB) instance, from 0-3. The instance specific program options replace `[-feature {value}]`.

value	Family
{setup_security:on/off}	SmartFusion
{prog_fpga:on/off}	SmartFusion
{prog_from:on/off}	SmartFusion
{prog_nvm:on/off}	SmartFusion
{setup_security}	Fusion
{prog_from}	Fusion
{all}	IGLOO; ProASIC3

In Tcl mode for Fusion, programming all features are turned off by default. If there is `-feature {setup_security}` or `-feature {prog_from}` the programming for the corresponding feature is activated.

In Tcl mode for SmartFusion, the programming option is read from the loaded PDB and then updated from the command if the is parameter specified. If programming of specific features is disabled, other parameters related to the feature programming are ignored. For example, if `-feature {prog_fpga:off}`, then `-fdb_file` and `-fdb_source` are ignored.

`-secured_device value`

Specifies whether the device you are programming is secured. You can specify yes or no to enable or disable secured programming.

`-signature value`

Optional argument that identifies and tracks Actel designs and devices.

`-pass_key value`

Protects all the security settings for FPGA Array, FlashROM, and Embedded Flash Memory Block. The maximum length of this value is 32 characters. You must use hexadecimal characters for the pass key value.

`-aes_key value`

Decrypts FPGA Array and/or FlashROM and Embedded Flash Memory Block programming file content.

Max length is 32 HEX characters.

`-from_config_file value`

Specifies the location of the FlashROM configuration file.

`-number_of_devices value`

Specifies the number of devices you want to program. Applicable only when FlashROM has serialization regions.

`-from_progfile_type value`

Applicable only when FlashROM has serialization regions and STAPL file generation. Possible values:

Value	Description
single	Generates one programming file with all the generated incremental value(s) in the external source file
multiple	Generates one individual programming file for each generated incremental value(s) in the external source file

`-target_programmer value`

Applicable only when FlashROM has serialization regions and STAPL file generation. Possible values:

Value	Description
specific	Silicon Sculptor, BP Auto Programmer, or FlashPro
generic	Generic STAPL player

`-custom_security value`

Possible values:

Value	Description
yes	Custom security level
no	Standard security level

`-fpga_security_level value`

Possible values:

Value	Description
write_verify_protect	The security level is medium (standard) and the FPGA Array cannot be written or verified without

Value	Description
	a Pass Key
write_protect	The security level is write protected. The FPGA Array cannot be written without a Pass Key, but it is open for verification (custom FPGA)
encrypted	The security level is high (standard) and uses a 128-bit AES encryption
none	The FPGA Array can be written and verified without a Pass Key

-from\_security\_level *value*

Possible values:

Value	Description
write_verify_protect	The security level is medium (standard) and the FlashROM cannot be read, written or verified without a Pass Key
write_protect	The security level is write protected. The FlashROM cannot be written without a Pass Key, but it is open for reading and verification (custom FlashROM)
encrypted	The security level is high (standard) and uses a 128-bit AES encryption
none	The FlashROM can be written and verified without a Pass Key

-security\_permanent *value*

Specifies whether the security settings for this file are permanent or not. Possible values:

Value	Description
yes	Permanently disable future modification of security settings for FPGA Array and FlashROM
no	Enable future modifications for FPGA Array and FlashROM

`-from_program_pages "value"`

Specifies FROM program pages in FlashPoint. If you use FlashROM content from an ADB file and do not specify a value, FlashPoint uses the same pages that were selected for programming in the previous FlashPoint session. Value may be a sequence of page numbers ("123") without a delimiter, or you can use any character or space as a delimiter, as in `-from_program_pages "1 2 3"`.

You must specify pages for programming if you want FlashROM content from the UFC file.

`-from_content "value"`

Identifies the source file for the FlashROM content- a UFC or ADB file.

If this Tcl parameter is missing, FlashPoint tries to use the ADB as a source of FROM configuration and content data.

Values are shown in table below:

Value	Description
adb	(default)FROM content is taken from your ADB. Configurations from your UFC and ADB files are not compared.
ufc	FlashPoint uses FROM configuration and FROM content from the specified UFC file

`-set_io_state value`

Sets the I/O state during programming by port name or pin number. You can also use this argument to save or load an IOS file.

To set the I/O by port name, use `-set_io_state {portName:<name>; state:<state>}`. To set the I/O port by pin number, use `-set_io_state {pinNumber:<number>; state:<state>}`. To set all I/Os to the specified state, use `-set_io_state {all; state:<state>}`.

To set BSR values for an I/O, use `-set_io_state { pinNumber:<pin>; input:<state>; output_enable:<state>;output:<state> }`. See the [Boundary Scan Registers - Show BSR Details](#) section of the FlashPoint help for more information on setting Boundary Scan Registers in your device.

The following table shows the possible values for this option if you have NOT set BSR values.

Value	Description
Z	Tri-State - Sets the I/O state to tristate
Last Known State	Sets the I/O to the last known state
1	High - Sets the I/O state to high
0	Low - Sets the I/O state to low

The following table shows the possible values for this option if you have set custom BSR values.

Value	Description
-------	-------------

Value	Description
Last State	Sets the I/O to the last known state
1	High - Sets the I/O state to high
0	Low - Sets the I/O state to low

To save an IOS file use the argument `-set_io_state { save:<filepath> }`

To load an IOS file, use the argument `-set_io_state { load:<filepath> }`

`-efm_block_security{location:X;security_level: value }`

This option is available only for Fusion; X identifies an Embedded Flash Memory Block instance from 0-3.

Possible values:

Value	Description
write_verify_protect	The security level is medium (standard) and the Embedded Flash Memory Block cannot be read, written or verified without a Pass Key
write_protect	The security level is write protected. The Embedded Flash Memory Block cannot be written without a Pass Key, but it is open for reading (custom FB)
encrypted	The security level is high (standard) and uses a 128-bit AES encryption
none	The Embedded Flash Memory Block can be written and read without a Pass Key

`-efm_content {location:X;source: value }`

This option is available only for Fusion; X identifies an Embedded Flash Memory Block instance from 0-3. Option identifies the source file for the Embedded Flash Memory Block content, either an EFC or ADB file.

If you wish to program the entire Embedded Flash Memory Block including all its clients that were programmed in previous sessions, and use ADB content for this client, this is the only parameter you must specify. If you wish to program the entire Embedded Flash Memory Block including all its clients and use the Embedded Flash Memory Block map file (EFC) you also have to specify the `-efm_block` parameter.

Possible values:

Value	Description
adb	(default) Embedded Flash Memory Block content is taken from your ADB

Value	Description
efc	FlashPoint uses the Embedded Flash Memory Block instance configuration and content from the EFC file specified in <code>-efm_block_parameter</code>

```
-efm_block {location:X;source: value}
```

This option is available only for Fusion; X identifies an Embedded Flash Memory Block (EFMB) instance from 0-3. Config\_file specifies the location of the EFMB instance configuration file (must be an EFC file with full pathname).

```
-efm_client {location:X;client:value; mem_file: value}
```

This option is available only for Fusion; X identifies an EFMB instance from 0-3.

You must specify the client name and its memory content file for each client of EFMB you wish to program.

Mem\_file specifies the file with the memory content for the client. If a mem\_file path is specified, the memory content from this file will overwrite the client content in ADB or EFC (as defined by the `-efm_content` argument). If the client memory file is not specified, the client memory content from the ADB or EFC file is used instead (as defined by the `-efm_content` argument).

```
{filename}
```

Specifies the path and name of the file you are exporting.

## Supported Families

IGLOO, ProASIC3, SmartFusion and Fusion

## Notes

- None

## Exceptions

- None

## Examples

```
export -format "bts_stp"
-feature "all"
-secured_device "no"
-signature "123"
-pass_key "FB318707864EC889AE2ED8904B8EB30D"
-custom_security "no"
-fpga_security_level "write_verify_protect"
-from_security_level "write_verify_protect"
-from_config_file {.\g3_test\from.ufc}
-number_of_devices "1"
-from_progfile_type "single"
-target_programmer "specific" \
{.\flp4.stp}
```

The following example uses the `-set_io_state` argument:

```
export \
-format "pdb " \
-feature "setup_security" \
-secured_device "no" \
-custom_security "no" \
-security_level "write_verify_protect" \
-security_permanent "no" \
-pass_key "012EB311B02E4C9A150B0F2BD8861CA0" \
-set_io_state { portName:AG9; state:Low} \
-set_io_state { pinNumber:AG10; state:High} \
-set_io_state { pinNumber:197; state:Tri-State} \
-set_io_state { pinNumber:198; state:Low} \
-set_io_state { pinNumber:199; state>Last Known State} \
{D:/designs/Fusion/DESIGN77}
```

Fusion example 1:

Export `soc.pdb` file that includes programming data for three clients of EFM block 0. EFM block configuration file `./fus_new/nvm_simple/nvm_simple.efc` and clients memory files are used for generating the programming file. Clients specified as TCL parameters must be included in EFC file.

```
export -format "pdb "
-efm_content {location:0; source:efc} \
-efm_block {location:0; config_file:{./fus_new/nvm_simple/nvm_simple.efc}} \
-efm_client {location:0; client:cfiData;
mem_file:{./fus_new/nvm_exmp/input_memfiles/ram1_block_0_ram1_R0C0.mem}} \
-efm_client {location:0; client:dataStorage;
mem_file:{./fus_new/nvm_exmp/input_memfiles/datast2_asbl_smtr_ram.hex}} \
-efm_client {location:0; client:init1;
mem_file:{./fus_new/nvm_exmp/input_memfiles/datast1_asbl_acm_rtc_ram.hex}} \
{./soc} Fusion example 2:
```

Export `soc.stp` and `soc.pdb` files that include programming data for EFM block 0. Information regarding block configuration, which clients to program, and their memory content is taken from ADB file.

```
export -format "pdb bts_stp"
-efm_content {location:0; source:adb} \
{./soc}
```

Fusion example 3:

Export `soc.stp` and `soc.pdb` files that include programming data for client `cfiData` of EFM block 0. Other clients of block 0 are not selected to be programmed. ADB file is a source for block configuration and content; EFC is ignored.

```
export -format "pdb"
-efm_content {location:0; source:adb} \
-efm_block {location:0; config_file:{./fus_new/nvm_simple/nvm_simple.efc}} \
-efm_client {location:0; client:cfiData;} \
{./soc}
```

**See Also**

[export \(ProASIC<sup>PLUS</sup>, Axcelerator, ProASIC, MX, eX, and SX/SX-A\)](#)

[Exporting files](#)

[Importing files](#)

[Tcl documentation conventions](#)

## export (ProASIC<sup>PLUS</sup>, ProASIC, Axcelerator, MX, eX, and SX/SX-A)

Saves your design to a file in the specified file format. The required and optional arguments for this command depend on which file format you specify.

```
export -format file_type{filename}
export -format edif -edif_flavor value {filename}
export -format file_type [-signature value] {filename}
export -format log [-diagnostic] {filename}
export -format sdf [-prelayout] {filename} -axprg_set_algo {programming algorithm}
```

**Arguments**

-format *file\_type*

Specifies the file format of the file to export. You can export one of the following types of files: edif, afm, dio, fus, log, sdf, adl, afl, cob, crt, dcf, design\_script, loc, pin, session\_script, stf, tcl, verilog, vhdl, crt, dcf, stp, pdc, stamp, gcf, prb, or sdc.

-edif\_flavor (*value*)

The acceptable values for this argument are generic, viewlogic, mgc, orcad, or workview.

-signature *value*

Optional for afm, dio, and fus file types.

-diagnostic

Optional for Log files. Specifies that you want detailed messages exported to a Log file.

-prelayout

Optional for .sdf files.

-axprg\_set\_algo {*programming algorithm*}

Sets the programming algorithm for your RTAX250S, RTAX1000S, or RTAX2000S device. Options are described in the table below.

Value	Description
OPA	Original programming algorithm; generates the OPA AFM file for your device.
UMA	UMC modified algorithm; generates the UMC AFM file for your device

{*filename*}

Specifies the path and name of the file you are exporting.



## Notes

- When exporting a Tcl script, remove the `design_script` and `session_script` values as follows:

```
export -format tcl -scope session
export -format tcl -scope design
```

"Session" refers to the Tcl commands of the entire Designer session; a session in Designer starts when you open the application and ends when you close it. "Design" refers to the Tcl commands for the current design only.

## Supported Families

ProASIC<sup>PLUS</sup>, ProASIC, Axcelerator, MX, eX, and SX/SX-A

## Notes

- None

## Exceptions

- None

### See Also

[export \(IGLOO, Fusion, and ProASIC3 families\)](#)

[Exporting files](#)

[Importing files](#)

[Tcl documentation conventions](#)

# export (Designer Block support for IGLOO, Fusion, ProASIC3, Axcelerator, and RTAX families)

Exports (publishes) the Designer Block files to a specified directory, includes any added comments.

```
export -format "block"
-export_directory {value} \
-export_name "blockname" \
-placement "value" \
-routing "value" \
-comment "value" \
-export_language "value" \
-region "value"
```

## Arguments

`-export_directory {value}`

Specifies the directory name for the exported \*.v, \*.vhd, \*.xcf and \*.cdb files. Value is the path and name of the directory

`-export_name "blockname"`

Specifies the prefix of the exported \*.v, \*.vhd, \*.xcf, and \*.cdb files, where blockname is the name of the prefix.

`-placement "value"`

Exports placement information. Possible values:

Value	Description
yes	Exports the placement information. Specify "yes" only if the placer state is valid and -placement is specified as "yes."
no	Do not export the placement information.

`-routing "value"`

Exports placement information. Possible values:

Value	Description
yes	Exports routing information. Specify "yes" only if the routing state is valid and -placement is specified as "yes."
no	Do not export the routing information.

`-comment "value"`

Adds comments to document the block.

`-export_language "value"`

Specifies the export format of the CXF file for Libero IDE. Possible values:

Value	Description
VERILOG	CXF file is Verilog.
VHDL	CXF file is VHDL.

`-region "value"`

Option to publish all the user regions and make them available when you instantiate the block. Possible values:

Value	Description
YES	Publishes all the user regions, makes them available when you instantiate your block.
NO	Disables region publishing

## Supported Families

IGLOO, Fusion, ProASIC3, Axcelerator, and RTAX

## Exceptions

- None

### Example

```
export -format "block" -export_directory {.} -export_name "test_core" -placement "yes" -  
routing "yes" -comment "toto" -export_language "VERILOG"
```

### See Also

[Exporting files](#)

[Importing files](#)

[Tcl documentation conventions](#)

## generate\_probes

Executes the probing and creates a new ADB file. This command is used in conjunction with the [add\\_probe](#) Tcl command (see example below).

```
generate_probes -save <ADB_file_name>
```

## Arguments

-save <ADB\_file\_name>

Name of the new ADB file with your probed nets.

## Supported Families

IGLOO, ProASIC3, SmartFusion and Fusion

## Exceptions

None

## Example

The example below adds a probe to the net net2 on pin 4 and port prb2 with the [add\\_probe](#) command, and generates the new ADB file test1.adb.

```
add_probe -net net2 -pin 4 -port prb2  
generate_probes -save test1.adb
```

### See Also

[add\\_probe](#)

[Generating a Probed Design](#)

[Generate Probed Design - Add Probe\(s\) Dialog Box](#)

## get\_cells

Returns an object representing the cells (instances) that match those specified in the pattern argument.

```
get_cells pattern
```

### Arguments

*pattern*

Specifies the pattern to match the instances to return. For example, "get\_cells U18\*" returns all instances starting with the characters "U18", where "\*" is a wildcard that represents any character string.

### Supported Families

IGLOO, ProASIC3, SmartFusion, Fusion, ProASIC<sup>PLUS</sup>, ProASIC, Axcelerator, RTAX-S, eX, and SX-A

### Description

This command returns a collection of instances matching the pattern you specify. You can only use this command as part of a `-from`, `-to`, or `-through` argument in the following Tcl commands: [set\\_max\\_delay](#), [set\\_multicycle\\_path](#), and [set\\_false\\_path](#).

### Exceptions

- None

### Examples

```
set_max_delay 2 -from [get_cells {reg*}] -to [get_ports {out}]
set_false_path -through [get_cells {Rblock/muxA}]
```

#### See Also

[get\\_clocks](#)

[get\\_nets](#)

[get\\_pins](#)

[get\\_ports](#)

[Tcl Command Documentation Conventions](#)

## get\_clocks

Returns an object representing the clock(s) that match those specified in the pattern argument in the current timing scenario.

```
get_clocks pattern
```

### Arguments

*pattern*

Specifies the pattern to use to match the clocks set in SmartTime or Timer.

## Supported Families

IGLOO, ProASIC3, SmartFusion, Fusion, ProASIC<sup>PLUS</sup>, ProASIC, Axcelerator, RTAX-S, eX, and SX-A

## Description

- If this command is used as a `-from` argument in either the set maximum ([set\\_max\\_delay](#)), or set minimum delay ([set\\_min\\_delay](#)), false path ([set\\_false\\_path](#)), and multicycle constraints ([set\\_multicycle\\_path](#)), the clock pins of all the registers related to this clock are used as path start points.
- If this command is used as a `-to` argument in either the set maximum ([set\\_max\\_delay](#)), or set minimum delay ([set\\_min\\_delay](#)), false path ([set\\_false\\_path](#)), and multicycle constraints ([set\\_multicycle\\_path](#)), the synchronous pins of all the registers related to this clock are used as path endpoints.

## Exceptions

- None

## Example

```
set_max_delay -from [get_ports data1] -to \  
[get_clocks ck1]
```

### See Also

[create\\_clock](#)  
[create\\_generated\\_clock](#)  
[Tcl Command Documentation Conventions](#)

## get\_current\_scenario

Returns the name of the current timing scenario.

```
get_current_scenario
```

## Arguments

None

## Supported Families

IGLOO, ProASIC3, SmartFusion, Fusion, Axcelerator, and RTAX-S

## Exceptions

None

## Examples

```
get_current_scenario
```

### See Also

[set\\_current\\_scenario](#)

[Tcl documentation conventions](#)

## get\_defvar

Provides access to the internal variables within Designer and returns its value. This command also prints the value of the Designer variable on the Log window.

```
get_defvar variable
```

### Arguments

*variable*

The Designer internal variable.

### Supported Families

All

### Exceptions

- None

### Example

Example 1: Prints the design name on the log window.

```
get_defvar "DESIGN"  
set variableToGet "DESIGN"  
set valueOfVariable [get_defvar $variableToGet]  
puts "The value is $valueOfVariable"
```

### See Also

[set\\_defvar](#)

## get\_design\_filename

Retrieves the full qualified path of the design file. The result will be an empty string if the design has not been saved to disk. This command is equivalent to the command “get\_design\_info DESIGN\_PATH.” This command predates get\_design\_info and is supported for backward-compatibility.

```
get_design_filename
```

### Arguments

None

## Supported Families

All

## Exceptions

- The command will return an error if a design is not loaded.
- The command will return an error if arguments are passed.

## Example

```
if { [ is_design_loaded ] } {
  set design_location [ get_design_filename ]
  if { $design_location != "" } {
    puts "Design is at $design_location."
  } else {
    puts "Design has not been saved to a file on disk."
  }
} else {
  puts "No design is loaded."
}
```

## See Also

[get\\_design\\_info](#)

[is\\_design\\_loaded](#)

[is\\_design\\_modified](#)

[is\\_design\\_state\\_complete](#)

## get\_design\_info

Retrieves some basic details of your design. The result value of the command will be a string value.

```
get_design_info value
```

## Arguments

*value*

Must be one of the valid string values summarized in the table below:

Value	Description
name	Design name. The result is set to the design name string.
family	Silicon family. The result is set to the family name.
design_path	Fully qualified path of the design file. The result is set to the location of the .adb file. If a design has not been saved to disk, the result will be an empty string. This command

Value	Description
	replaces the command <code>get_design_filename</code> .
<code>design_folder</code>	Directory (folder) portion of the <code>design_path</code> .
<code>design_file</code>	Filename portion of the <code>design_path</code> .
<code>cwdir</code>	Current working directory. The result is set to the location of the current working directory
<code>die</code>	Die name. The result is set to the name of the selected die for the design. If no die is selected, this is an empty string.
<code>Package</code>	Package. The result is set to the name of the selected package for the design. If no package is selected, this is an empty string.
<code>Speed</code>	Speed grade. The result is set to the speed grade for the design. If no speed grade is selected, this is an empty string.

## Supported Family

All

## Exceptions

- Returns an error if a design is not loaded.
- Returns an error if more than one argument is passed.
- Returns an error if the argument is not one of the valid values.

## Example

The following example uses `get_design_info` to display the various values to the screen.

```
if { [ is_design_loaded ] } {
    puts "Design is loaded."
    set bDesignLoaded 1
} else {
    puts "No design is loaded."
    set bDesignLoaded 0
}
if { $bDesignLoaded != 0 } {
```



```

set var [ get_design_info NAME ]
puts " DESIGN NAME:\t$var"
set var [ get_design_info FAMILY ]
puts " FAMILY:\t$var"
set var [ get_design_info DESIGN_PATH ]
puts " DESIGN PATH:\t$var"
set var [ get_design_info DESIGN_FILE ]
puts " DESIGN FILE:\t$var"
set var [ get_design_info DESIGN_FOLDER ]
puts " DESIGN FOLDER:\t$var"
set var [ get_design_info CWDIR ]
puts " WORKING DIRECTORY: $var"
set var [ get_design_info DIE ]
puts " DIE:\t$var"
set var [ get_design_info PACKAGE ]
puts " PACKAGE:\t'$var'"
set var [ get_design_info SPEED ]
puts " SPEED GRADE:\t$var"
if { [ is_design_modified ] } {
    puts "The design is modified."
} else {
    puts "The design is unchanged"
}
}
puts "get_design.tcl done"

```

### See Also

[get\\_design\\_filename](#)  
[is\\_design\\_loaded](#)  
[is\\_design\\_modified](#)  
[is\\_design\\_state\\_complete](#)

## get\_nets

Returns an object representing the nets that match those specified in the pattern argument.

```
get_nets pattern
```

### Arguments

*pattern*

Specifies the pattern to match the names of the nets to return. For example, "get\_nets N\_255\*" returns all nets starting with the characters "N\_255", where "\*" is a wildcard that represents any character string.

### Supported Families

IGLOO, ProASIC3, SmartFusion, Fusion, ProASIC<sup>PLUS</sup>, ProASIC, Axcelerator, RTAX-S, eX, and SX-A

## Description

This command returns a collection of nets matching the pattern you specify. You can only use this command as source objects in create clock ([create\\_clock](#)) or create generated clock ([create\\_generated\\_clock](#)) constraints and as - through arguments in the set false path, set minimum delay, set maximum delay, and set multicycle path constraints.

## Exceptions

- None

## Examples

```
set_max_delay 2 -from [get_ports RDATA1] -through [get_nets {net_chkp1 net_chkqi}]
set_false_path -through [get_nets {Tblk/rm/n*}]
create_clock -name mainCLK -period 2.5 [get_nets {cknet}]
```

## See Also

[create\\_clock](#)  
[create\\_generated\\_clock](#)  
[set\\_false\\_path](#)  
[set\\_min\\_delay](#)  
[set\\_max\\_delay](#)  
[set\\_multicycle\\_path](#)  
[Tcl documentation conventions](#)

## get\_out\_of\_date\_files

Audits all files returns a list of filenames that are out of date; each filename is separated by a space. The command returns a string of file names that are out of date separated by a space

i.e. file1 file2 ...

It returns empty string if all files are current.

This command ignores the Audit settings in your ADB file.

```
get_out_of_date_files
```

## Arguments

None

## Supported Family

All

## Exceptions

- None

## Example

The following code returns a list of filenames that are out of date.

```
get_out_of_date_files
```

### See Also

[are\\_all\\_source\\_files\\_curent](#)

[is\\_source\\_file\\_current](#)

## get\_pins

Returns an object representing the pin(s) that match those specified in the pattern argument.

```
get_pins pattern
```

## Arguments

*pattern*

Specifies the pattern to match the pins to return. For example, "get\_pins clock\_gen\*" returns all pins starting with the characters "clock\_gen", where "\*" is a wildcard that represents any character string.

## Supported Families

IGLOO, ProASIC3, SmartFusion, Fusion, ProASIC<sup>PLUS</sup>, ProASIC, Axcelerator, RTAX-S, eX, and SX-A

## Exceptions

- None

## Example

```
create_clock -period 10 [get_pins clock_gen/reg2:Q]
```

### See Also

[create\\_clock](#)

[create\\_generated\\_clock](#)

[set\\_clock\\_latency](#)

[set\\_false\\_path](#)

[set\\_min\\_delay](#)

[set\\_max\\_delay](#)

[set\\_multicycle\\_path](#)

[Tcl documentation conventions](#)

## get\_ports

Returns an object representing the port(s) that match those specified in the pattern argument.

```
get_portspattern
```

## Argument

*pattern*

Specifies the pattern to match the ports.

## Supported Families

IGLOO, ProASIC3, SmartFusion, Fusion, ProASIC<sup>PLUS</sup>, ProASIC, Axcelerator, RTAX-S, eX, and SX-A

## Exceptions

- None

## Example

```
create_clock -period 10 [get_ports CK1]
```

### See Also

[create\\_clock](#)  
[set\\_clock\\_latency](#)  
[set\\_input\\_delay](#)  
[set\\_output\\_delay](#)  
[set\\_min\\_delay](#)  
[set\\_max\\_delay](#)  
[set\\_false\\_path](#)  
[set\\_multicycle\\_path](#)  
[Tcl documentation conventions](#)

## import\_aux

Imports the specified auxiliary file into the design. Equivalent to executing the Import Auxiliary Files command from the File menu.

```

import_aux
-format file_type-partial_parse value
-start_time value
-end_time value
-auto_detect_top_level_name value
-top_level_name value
-glitch_filtering value
-glitch_threshold value
filename

```

## Arguments

-format *file\_type*

Specifies the file format of the file to import. You can import one of the following types of files: pdc, sdc, pin, dcf, saif, vcd, or crt.

-partial\_parse {*value*}

Specifies whether to partially parse the \*.vcd file. The following table shows the acceptable values for this argument:

Value	Description
true	Partially parses the *.vcd file
false	Does not partially parse the *.vcd file

`-start_time {value}`

This option is available only if `-partially_parse` is set to `true`. Specifies the start time (in ns) to partially parse the \*.vcd file.

`-end_time {value}`

This option is available only if `-partially_parse` is set to `true`. Specifies the end time (in ns) to partially parse the \*.vcd file.

`-auto_detect_top_level_name {value}`

Specifies whether to automatically detect the top-level name. The following table shows the acceptable values for this argument:

Value	Description
true	Automatically detects the top-level name
false	Does not automatically detect the top-level name

`-top_level_name top_level_name`

Specifies the instance name of your design in the simulation testbench when you import a VCD or SAIF file.

When importing a VCD file, the automatic `top_level_name` detection is available. If the `-top_level_name` option is not specified, SmartPower will try to automatically detect the top level name.

When importing a SAIF file, the automatic `top_level_name` detection is not available and `-top_level_name` is a required argument.

To identify the `top_level_name` for SAIF and VCD files manually, refer to [Importing a VCD file](#) and [Importing a SAIF file](#).

`-glitch_filtering {value}`

Specifies whether to use glitch filtering. The following table shows the acceptable values for this argument:

Value	Description
true	Glitch filtering is on
auto	Enables automatic glitch filtering. This option will ignore any value specified in <code>-glitch_threshold</code>
false	Glitch filtering is off

`-glitch_threshold {value}`

This option is only available when `-glitch_filtering` is set to `true`. Specifies the glitch filtering value in ps.

filename  
Specifies the name of the auxiliary file to import.

## Supported Families

IGLOO, Fusion, ProASIC3, ProASIC<sup>PLUS</sup>, ProASIC, Axcelerator, MX, eX, SX/SX-A

## Description

- Auxiliary files are not audited and are handled as one-time data-entry or data-change events, similar to entering data using one of the interactive editors (for example, PinEditor or Timer).
- If you import the SDC file as an auxiliary file, you do not have to re-compile your design. However, auditing is disabled when you import auxiliary files, and Designer cannot detect the changes to your SDC file(s) if you import them as auxiliary files.

## Exceptions

- None

## Examples

```
import_aux -format sdc file.sdc
import_aux -format pdc file.pdc
import_aux -format vcd file.vcd // automatic detection of top level name
import_aux -format vcd -glitch_filter 10 // filter out glitches that are 10 ps or less
import_aux -format saif -top_level_name "top" file.saif
```

### See Also

[import\\_source](#)

[Importing auxiliary files](#)

[Importing source files](#)

[Importing files](#)

[Tcl documentation conventions](#)

## import\_source

Imports the specified source file into the design. Equivalent to executing the Import Source File command from the File menu.

All source files must be specified on one command line.

```
import_source [-merge_timing value][-merge_physical value][-merge_all value][-format
file_type][-abort_on_error value][-top_entity][-edif -edif_flavor value]filename
```

## Arguments

-merge\_timing *value*

Specifies whether to preserve all existing timing constraints when you import an SDC file. Same as selecting or unselecting the "Keep existing timing constraints" check box in the Import Files dialog box. The following table shows the acceptable values for this option:

Value	Description
yes	Designer merges the timing constraints from the imported SDC file with the existing constraints saved in the constraint database. If there is a conflict, the new constraint has priority over the existing constraint.
no	All existing timing constraints are replaced by the constraints in the newly imported SDC file.

`-merge_physical` *value*

Specifies whether to preserve all existing physical constraints when you import a GCF or PDC file. Same as selecting or unselecting the "Keep existing physical constraints" check box in the Import Files dialog box. The following table shows the acceptable values for this option:

Value	Description
yes	Designer preserves all existing physical constraints that you have entered either using one of the MVN tools (ChipPlanner, PinEditor, or the I/O Attribute Editor) or a previous GCF or PDC file. The software resolves any conflicts between new and existing physical constraints and displays the appropriate message.
no	All existing physical constraints are replaced by the constraints in the newly imported GCF or PDC file.

`-merge_all` *value*

Specifies whether to preserve all existing physical and timing constraints when you import an SDC and/or a PDC file. Same as selecting or unselecting the "Keep existing physical constraints" and "Keep existing timing constraints" check boxes in the Import Files dialog box. The following table shows the acceptable values for this option:

Value	Description
yes	Designer preserves all existing physical constraints that you have entered either using one of the MVN tools (ChipPlanner, PinEditor, or the I/O Attribute Editor) or a previous GCF or PDC file. The software resolves any conflicts between new and existing physical constraints and displays an appropriate message. Any existing timing constraints from your ADB are merged with the new information from your imported files. New constraints override any existing timing

Value	Description
	constraints whenever there is a conflict
no	All the physical constraints in the newly imported GCF or PDC files are used. All pre-existing physical constraints are lost. Existing timing constraints from the ADB are replaced by the new timing constraints from your imported file.

`-format` *file\_type*

Specifies the file format of the file to import. You can import one of the following types of files: adl, edif, verilog, vhdl, gcf, pdc, sdc, or crt.

**Note:** Note: Refer to Importing source file to know the formats supported for each family.

`-abort_on_error` *value*

Aborts a PDC file if it encounters an error during import. Possible values are

Value	Description
yes	Designer aborts on error.
no	Designer ignores the error and continues.

`-top_entity`

Specifies the top entity to a VHDL file.

`-edif` *edif\_flavor* *value*

Specifies the type of netlist. It can be edif, viewlogic, or mgc.

*filename*

Specifies the name of the source file to import.

## Supported Families

IGLOO, Fusion, ProASIC3, ProASIC<sup>PLUS</sup>, Axcelerator, ProASIC, MX, eX, SX/SX-A

## Exceptions

Your script `-merge` options vary according to family as shown below:

- The `-merge_timing`, `-merge_physical`, and `-merge_all` arguments are available for IGLOO, Fusion, ProASIC3, ProASIC<sup>PLUS</sup>, ProASIC, and Axcelerator families.
- For source SDC (no PDC/GCF) in eX and SX-A:

```
import_source -merge_timing yes/no ...
```



```
import_source -merge yes/no ...
import_source -merge_all yes/no ...
```

The eX and SX-A families do not support merging of physical constraints. For these families, in import\_source, the -merge\_all and -merge options are mapped just to -merge\_timing.

- For constraints in ProASIC<sup>PLUS</sup>:

```
import_source -merge_physical yes/no ...
import_source -merge_all yes/no ...
import_source -merge yes/no ...
```

ProASIC<sup>PLUS</sup> and ProASIC support GCF, but the -merge option in the import\_source only affects GCF in terms of the physical constraints.

- ProASIC does not support PreCompile import of the SDC files. The -merge\_timing option has no effect on this import\_source for ProASIC. The -merge\_all and -merge options map to -merge\_physical for ProASIC in import\_source.
- For IGLOO, Fusion, ProASIC3, ProASIC<sup>PLUS</sup>, and Axcelerator:

```
import_source -merge_physical yes/no -merge_timing yes/no ...
import_source -merge_all yes/no ...
import_source -merge yes/no ...
```

The -merge\_all and -merge options map to both -merge\_physical and -merge\_timing options for these families.

## Examples

Consider the following sample scripts:

```
import_source \
  -merge_physical "no" \
  -merge_timing "yes"
  -format "EDIF" -edif_flavor "GENERIC" \
  {.\designs\mydesign.edn} \
  -format "sdc" \
  {.\designs\mydesign.sdc} \
  -format "pdc" -abort_on_error "no" \
  {.\designs\mydesign.pdc}
```

```
import_source \
  -merge_physical "no" \
  -format "verilog" \
  {mydesign.v}
```

```
import_source \
  -merge_physical "no" \
  -merge_timing "no" \
  -format "vhdl" -top_entity "aclass" \
  {C:/mynetlist.vhd}
```

```
import_source \
  -merge_physical "no" \
  -merge_timing "no" \
  -format "adl" {mydesign.adl}
```

### See Also

[import\\_aux](#)

[Importing auxiliary files](#)

[Importing source files](#)

[Importing files](#)

[Tcl documentation conventions](#)

## ioadvisor\_apply\_suggestion

Applies the suggestions for the selected attribute to the selected I/O(s).

```
ioadvisor_apply_suggestion -attribute {value} -io {value}
```

### Arguments

`-attribute{value}`

This specifies the attribute for which the values will be applied. The following table shows the acceptable values for this argument:

Value	Description
outdrive	Applies suggested outdrive values
slew	Applies suggested slew values

`-io {value}`

This selects the I/Os for which the suggestion will be applied. To select multiple I/Os, use `-io {value}` for each I/O.

### Supported Families

All

### Exceptions

- None

### Example

The following code applies the suggested outdrive values for two I/Os.

```
ioadvisor_apply_suggestion -attribute{outdrive} -io{nPWM_out_pad} -io{PWM_out_pad}
```

### See Also

[ioadvisor\\_commit](#)  
[ioadvisor\\_restore](#)  
[ioadvisor\\_restore\\_initial\\_value](#)  
[ioadvisor\\_set\\_outdrive](#)  
[ioadvisor\\_set\\_outputload](#)  
[ioadvisor\\_set\\_slew](#)

## ioadvisor\_commit

Saves all changes in the I/O Advisor.

```
ioadvisor_commit
```

### Arguments

- None

### Supported Families

All

### Exceptions

- None

### Example

The following code saves all changes in the I/O Advisor:

```
ioadvisor_commit
```

### See Also

[ioadvisor\\_apply\\_suggestion](#)  
[ioadvisor\\_restore](#)  
[ioadvisor\\_restore\\_initial\\_value](#)  
[ioadvisor\\_set\\_outdrive](#)  
[ioadvisor\\_set\\_outputload](#)  
[ioadvisor\\_set\\_slew](#)

## ioadvisor\_restore

Restores the I/O Advisor to the initial state. All changes not committed will be lost.

```
ioadvisor_restore
```

## Arguments

- None

## Supported Families

All

## Exceptions

- None

## Example

The following code restores the I/O Advisor to the initial state:

```
ioadvisor_restore
```

### See Also

[ioadvisor\\_apply\\_suggestion](#)  
[ioadvisor\\_commit](#)  
[ioadvisor\\_restore\\_initial\\_value](#)  
[ioadvisor\\_set\\_outdrive](#)  
[ioadvisor\\_set\\_outputload](#)  
[ioadvisor\\_set\\_slew](#)

## ioadvisor\_restore\_initial\_value

Sets the current value for the selected attribute and I/Os to the initial value.

```
ioadvisor_restore_initial_value -attribute {value} -io {value}
```

## Arguments

-attribute{*value*}

This specifies the attribute for which the values will be restored. The following table shows the acceptable values for this argument:

Value	Description
outdrive	Restores initial outdrive values
output_load	Restores initial output load values
slew	Restores initial slew values

-io {*value*}

This selects the I/Os for which the initial values will be restored. To select multiple I/Os, use -io {*value*} for each I/O.

## Supported Families

All

## Exceptions

- None

## Example

The following code restores the initial outdrive values for two I/Os.

```
ioadvisor_restore_initial_value -attribute{outdrive} -io{nPWM_out_pad} -io{PWM_out_pad}
```

### See Also

[ioadvisor\\_apply\\_suggestion](#)

[ioadvisor\\_commit](#)

[ioadvisor\\_restore](#)

[ioadvisor\\_set\\_outdrive](#)

[ioadvisor\\_set\\_outputload](#)

[ioadvisor\\_set\\_slew](#)

# ioadvisor\_set\_outdrive

Sets the outdrive for the selected I/Os.

```
ioadvisor_set_outdrive -io {value} -outdrive {value}
```

## Arguments

-io {value}

This selects the I/Os for which the outdrive will be set. To select multiple I/Os, use -io {value} for each I/O.

-outdrive {value}

This specifies the outdrive for the selected I/Os. The outdrive must be a positive integer value within the list of possible outdrives of the I/Os.

## Supported Families

All

## Exceptions

- None

## Example

The following code sets the outdrive for two I/Os.

```
ioadvisor_set_outdrive -io{nPWM_out_pad} -io{PWM_out_pad} -outdrive{5}
```

### See Also

[ioadvisor\\_apply\\_suggestion](#)  
[ioadvisor\\_commit](#)  
[ioadvisor\\_restore](#)  
[ioadvisor\\_restore\\_initial\\_value](#)  
[ioadvisor\\_set\\_outputload](#)  
[ioadvisor\\_set\\_slew](#)

## ioadvisor\_set\_outputload

Sets the output load for the selected I/Os.

```
ioadvisor_set_outputload -io {value} -outload {value}
```

### Arguments

-io {value}

This selects the I/Os for which the output load will be set. To select multiple I/Os, use -io {value} for each I/O.

-outload {value}

This specifies the output load for the selected I/Os. The output load must be a positive integer value.

### Supported Families

All

### Exceptions

- None

### Example

The following code sets the output load for two I/Os.

```
ioadvisor_set_outputload -io{nPWM_out_pad} -io{PWM_out_pad} -outload{5}
```

### See Also

[ioadvisor\\_apply\\_suggestion](#)  
[ioadvisor\\_commit](#)  
[ioadvisor\\_restore](#)  
[ioadvisor\\_restore\\_initial\\_value](#)  
[ioadvisor\\_set\\_outdrive](#)  
[ioadvisor\\_set\\_slew](#)

## ioadvisor\_set\_slew

Sets the slew for the selected I/Os.

```
ioadvisor_set_slew -io {value} -slew {value}
```

## Arguments

`-io {value}`

This selects the I/Os for which the slew will be set. To select multiple I/Os, use `-io {value}` for each I/O.

`-set_slew {value}`

This specifies the slew for the selected I/Os. The following table shows the acceptable values for this argument:

Value	Description
high	The slew is set to high.
low	The slew is set to low. This option is not available for all I/Os.

## Supported Families

All

## Exceptions

- None

## Example

The following code sets the slew for two I/Os.

```
loadadvisor_set_slew -io{nPWM_out_pad} -io{PWM_out_pad} -slew{high}
```

### See Also

[loadadvisor\\_apply\\_suggestion](#)

[loadadvisor\\_commit](#)

[loadadvisor\\_restore](#)

[loadadvisor\\_restore\\_initial\\_value](#)

[loadadvisor\\_set\\_outdrive](#)

[loadadvisor\\_set\\_outputload](#)

## is\_design\_loaded

Returns a Boolean value (0 for false, 1 for true) indicating if a design is loaded in the Designer software. True is returned if a design is currently loaded.

```
is_design_loaded
```

## Arguments

None

## Supported Family

All

## Description

Some Tcl commands are valid only if a design is currently loaded in Designer. Use the 'is\_design\_loaded' command to prevent runtime errors by checking for this before invoking the commands.

## Exceptions

- The command will return an error if arguments are passed.

## Example

The following code will determine if a design has been loaded.

```
set bDesignLoaded [ is_design_loaded ]
if { $bDesignLoaded == 0 } {
    puts "No design is loaded."
}
```

### See Also

[get\\_design\\_filename](#)

[get\\_design\\_info](#)

[is\\_design\\_modified](#)

[is\\_design\\_state\\_complete](#)

## is\_design\_modified

Returns a Boolean value (0 for false, 1 for true) indicating if a design has been modified in the Designer software.

True is returned if a design has been modified.

```
is_design_modified
```

## Arguments

None

## Supported Family

All

## Description

Some Tcl commands are valid only if a design has been modified in Designer. Use the is\_design\_modified command to prevent runtime errors by checking for this before invoking the commands.



## Exceptions

- Returns an error if arguments are passed.

## Example

The following code will determine if a design has been modified.

```
set bDesignModified [ is_design_modified ]
if { $bDesignModified == 0 } {
  puts "Design has not been modified."
}
```

### See Also

[get\\_design\\_filename](#)

[get\\_design\\_info](#)

[is\\_design\\_loaded](#)

[is\\_design\\_state\\_complete](#)

## is\_design\_state\_complete

Returns a Boolean value (0 for false, 1 for true) indicating if a specific design state is valid. True is returned if the specified design state is valid.

```
is_design_state_complete value
```

## Arguments

*value*

Must be one of the valid string values summarized in the table below:

Value	Description
SETUP_DESIGN	The design is loaded and the family has been specified for the design
DEVICE_SELECTION	The design has completed device selection (die and package). This corresponds to having successfully called the set_device command to set the die and package
NETLIST_IMPORT	The design has imported a netlist
COMPILE	The design has completed the compile command
LAYOUT	The design has completed the layout command
BACKANNOTATE	The design has exported a post-layout timing file (e.g.SDF)

Value	Description
PROGRAMMING_FILES	The design has exported a programming file (e.g. AFM)

## Supported Family

All

## Description

Certain commands can only be used after Compile or Layout has been completed. The `is_design_state_complete` command allows a script to check the design state before calling one of these state-limited commands.

## Exceptions

- The command will return an error if a design is not loaded.
- The command will return an error if more than one argument is passed.
- The command will return an error if the argument is not one of the valid values.

## Example

The following code runs layout, but checks that the design state for layout is complete before calling backannotate.

```
layout -timing_driven
set bLayoutDone [ is_design_state_complete LAYOUT ]
if { $bLayoutDone != 0 } {
    backannotate -name {mydesign_ba} -format "SDF" -language "verilog"
}
}
```

### See Also

[compile](#)  
[get\\_design\\_filename](#)  
[get\\_design\\_info](#)  
[is\\_design\\_loaded](#)  
[is\\_design\\_modified](#)  
[layout](#)  
[set\\_design](#)  
[set\\_device](#)

## is\_source\_file\_current

Audits the source file and determines whether or not the file is out of date / imported into the workspace. Returns '0' if file\_name is out of date or has not been imported into the workspace, and returns '1' if file\_name is current.

This command ignores the Audit settings in your ADB file.

```
is_source_file_current(filename)
```

## Arguments

*filename* is the path to the source file

## Supported Families

All

## Exceptions

- None

## Example

The following code determines whether or not the file has been imported into the workspace.

```
is_source_file_current (./hdl/adder.vhd)
```

### See Also

[are\\_all\\_source\\_files\\_curent](#)  
[get\\_out\\_of\\_date\\_files](#)

## layout - IGLOO, ProASIC3, SmartFusion and Fusion

This command is identical to the layout command in the Designer GUI. Refer to the [Advanced Layout Options below](#) for more information.

```
layout
[-timing_driven | -standard]
[-power_driven value]
[-run_placer value]
[-place_incremental value]
[-run_router value]
[-route_incremental value]
```

## Arguments

-timing\_driven | -standard

Sets layout mode to be timing driven or standard (non-timing driven). The default is -timing\_driven or the mode used in the previous layout command.

-power\_driven *value*

The following table shows the acceptable values for this argument:

Value	Description
off	Does not run power-driven layout. This is the default.
on	Enables power-driven layout

`-place_incremental value`

The following table shows the acceptable values for this argument:

Value	Description
off	Discards previous placement. This is the default.
on	Sets the previous placement as the initial starting point
fix	Sets the previously placed macros' locations as "fixed" and continues to place the remaining ones

`-route_incremental value`

The following table shows the acceptable values for this argument:

Value	Description
off	Skips incremental mode, discards previous information. This is the default.
on	Invokes incremental routing and sets the previous routing information as the initial starting point

`-run_placer value`

The following table shows the acceptable values for this argument:

Value	Description
on	Invokes placement. This is the default.
off	Skips placement

`-run_router value`

The following table shows the acceptable values for this argument:

Value	Description
on	Invokes routing if placement is successful. This is the default.
off	Skips routing

## layout - Advanced Options for IGLOO, ProASIC3, SmartFusion and Fusion

This is equivalent to executing commands within the Advanced Layout Options dialog box.

```
[-placer_high_effort value]
[-seq_opt value]
[-mindel_repair value]
[-placer_seed value]
[-show_placer_seed]
```

### Arguments

`-placer_high_effort value`

The following table shows the acceptable values for this argument:

Value	Description
off	Disables physical synthesis of combinational logic. This is the default.
on	Enables physical synthesis of combinational logic

`-seq_opt value`

The following table shows the acceptable values for this argument:

Value	Description
off	Disables physical synthesis of sequential logic. This is the default.
on	Enables physical synthesis of sequential logic in high-effort mode

`-mindel_repair value`

The following table shows the acceptable values for this argument:

Value	Description
off	Does not run minimum delay violations repair. This is the default.
on	Enables repair of minimum delay violations during route

`-placer_seed value`

An integer value that you can set to change the initial random seed number for the placement.

`-show_placer_seed value`

Causes Layout to display the initial random seed number used for the placement.

### Exceptions

- None

## Example

```
layout
layout -place_incremental FIX -route_incremental ON
layout -placer_high_effort ON
layout -run_placer OFF -route_incremental ON -mindel_repair ON
layout -timing_driven -power_driven ON
layout -placer_seed 120
```

## See Also

[IGLOO, ProASIC3, SmartFusion and Fusion Layout options](#)

[IGLOO, ProASIC3, SmartFusion and Fusion Advanced Layout options](#)

## layout - ProASIC and ProASIC<sup>PLUS</sup>

This command is identical to the layout command in the Designer GUI. Refer to the [Advanced Layout Options](#) below for more information.

```
layout
[-timing_driven | -standard]
[-place_incremental value]
[-route_incremental value]
[-run_placer value]
[-run_router value]
```

## Arguments

`-timing_driven | -standard`

Sets layout mode to be timing driven or standard (non-timing driven). The default is `-timing_driven` or the mode used in the previous layout command.

`-place_incremental value`

The following table shows the acceptable values for this argument:

Value	Description
off	Discards previous placement. This is the default.
on	Sets the previous placement as the initial starting point
fix	Sets the previously placed macros' locations as "FIXED" and continues to place the remaining ones

`-route_incremental value`

The following table shows the acceptable values for this argument:

Value	Description
off	Skips incremental mode, discards previous information. This is the default.

Value	Description
on	Invokes incremental mode, and sets the previous routing information as the initial starting point

`-run_placer value`

The following table shows the acceptable values for this argument:

Value	Description
on	Invokes placement. This is the default.
off	Skips placement

`-run_router|-router|-route value`

The following table shows the acceptable values for this argument:

Value	Description
on	Invokes routing if placement is successful. This is the default.
off	Skips routing

## layout - Advanced Layout Options for ProASIC and ProASIC<sup>PLUS</sup>

This is equivalent to executing commands within the Advanced Layout Options dialog box.

```
[ -timing_weight value ]
[ -placer_seed value ]
[ -show_placer_seed ]
```

### Arguments

`-timing_weight value`

The timing weight for the placement. Values range from 1 to 4 in whole integers. The lower numbers give less weight to timing in the placement. Timing weight 4 is the same as timing driven placement using the option `-timing_driven`.

`-placer_seed value`

An integer value that you can set to change the initial random seed number for the placement.

`-show_placer_seed`

Causes Layout to display the initial random seed number used for the placement.

### Exceptions

- None

## Example

```
layout
layout -standard
layout -timing_weight 3
layout -place_incremental FIX -route_incremental ON
layout -placer_seed 120
```

### See Also

[ProASICPLUS and ProASIC Layout Options](#)

[ProASICPLUS, ProASIC Advanced Layout Options](#)

## layout - Axcelerator

This command is identical to the layout command in the Designer GUI. Refer to the [Advanced Layout Options](#) below for more information.

```
layout
[-timing_driven | -standard]
[-power_driven value]
[-place_incremental value]
[-effort_level value]
[-route_incremental value]
[-run_placer value]
[-run_router value]
```

## Arguments

`-timing_driven` | `-standard`

Sets layout mode to be timing driven or standard (non-timing driven). The default is `-timing_driven` or the mode used in the previous layout command.

`-power_driven` *value*

The following table shows the acceptable values for this argument:

Value	Description
off	Does not run power-driven layout. This is the default.
on	Enables power-driven layout

`-place_incremental` *value*

The following table shows the acceptable values for this argument:

Value	Description
off	Discards previous placement. This is the default
on	Sets the previous placement as the initial starting point



Value	Description
fix	Sets the previously placed macros' locations as "fixed" and continues to place the remaining ones

`-effort_level value`

The effort level for the placement. Values range from 1 to 5 in whole integers. The lower numbers tend to give a result more quickly, but higher levels yield better performance in timing and routability.

`-route_incremental value`

The following table shows the acceptable values for this argument:

Value	Description
off	Skips incremental mode, discards previous information. This is the default.
on	Invokes incremental mode, and sets the previous routing information as the initial starting point

`-run_placer value`

The following table shows the acceptable values for this argument:

Value	Description
on	Invokes placement. This is the default.
off	Skips placement

`-run_router value`

The following table shows the acceptable values for this argument:

Value	Description
on	Invokes routing if placement is successful. This is the default.
off	Skips routing

## layout - Advanced Options for Axcelerator

This is equivalent to executing commands within the Advanced Layout Options dialog box.

```
[ -mindel_repair value ]
[ -placer_seed value ]
[ -show_placer_seed ]
```

## Arguments

`-mindel_repair` *value*

The following table shows the acceptable values for this argument:

Value	Description
off	Skips minimum delay violations repair. This is the default.
on	Invokes minimum delay violations repair

`-placer_seed` *value*

An integer value that you can set to change the initial random seed number for the placement.

`-show_placer_seed`

Causes Layout to display the initial random seed number used for the placement.

## Exceptions

N/A

## Example

```
layout
layout -timing_driven -effort_level 4
layout -place_incremental FIX -route_incremental ON
layout -placer_seed 120
layout -mindel_repair ON
```

### See Also

[Axcelerator Layout options](#)

[Axcelerator Advanced Layout options](#)

## layout - SX-A, eX, and SX

This command is identical to the layout command in the Designer GUI. Refer to the [Advanced Layout Options](#) below for more information.

```
layout
[-timing_driven | -standard]
[-place_incremental value]
```

## Arguments

`-timing_driven|-standard`

Sets layout mode to be timing driven or standard (non-timing driven). The default is `-timing_driven` or the mode used in the previous layout command.

`-place_incremental` *value*

The following table shows the acceptable values for this argument:

Value	Description
off	Discards previous placement. This is the default.
on	Sets the previous placement as the initial starting point
fix	Sets the previously placed macros' locations as "FIXED" and continues to place the remaining ones

## layout - Advanced Options for SX-A, eX, and SX

This is equivalent to executing commands within the Advanced Layout Options dialog box.

```
[ -extended_run value ]
[ -effort_level value ]
[ -timing_weight value ]
[ -placer_seed value ]
[ -show_placer_seed value ]
```

## Arguments

`-extended_run value`

The following table shows the acceptable values for this argument:

Value	Description
off	Skips extended run mode. This is the default.
on	Invokes extended run mode

`-effort_level value`

Sets the effort level; number may range from 25 to 500.

`-timing_weight value`

Sets the timing weight value; number may range from 10 to 150.

`-placer_seed value`

An integer value that you can set to change the initial random seed number for the placement.

`-show_placer_seed`

Causes Layout to display the initial random seed number used for the placement.

## Exceptions

- None

## Example

```
layout [ -timing_driven ] [ -incremental OFF ] [ -extended_run OFF ] [ -effort_level 50 ] [ -
timing_weight 100 ]
```

**See Also**[eX, SX, and SX-A Layout options](#)[eX, SX, and SX-A Advanced Layout options](#)

## layout - MX, DX, ACT

This command is identical to the layout command in the Designer GUI. Refer to the [Advanced Layout Options](#) below for more information.

```
layout
[-timing_driven | -standard]
[-place_incremental value]
```

### Arguments

`-timing_driven` | `-standard`

Sets layout mode to be timing driven or standard (non-timing driven). The default is `-timing_driven` or the mode used in the previous layout command.

`-place_incremental` *value*

The following table shows the acceptable values for this argument:

Value	Description
off	Discards previous placement. This is the default.
on	Sets the previous placement as the initial starting point
fix	Sets the previously placed macros' locations as "fixed" and continues to place the remaining ones

### layout - Advanced Options for MX, DX, ACT

This is equivalent to executing commands within the Advanced Layout Options dialog box.

```
[-extended_run value]
[-placer_seed value]
[-show_placer_seed]
```

### Arguments

`-extended_run` *value*

The following table shows the acceptable values for this argument:

Value	Description
off	Skips extended run mode. This is the default.

Value	Description
on	Invokes extended run mode

`-placer_seed` *value*

An integer value that you can set to change the initial random seed number for the placement.

`-show_placer_seed`

Causes Layout to display the initial random seed number used for the placement.

## Exceptions

- None

## Example

The following code runs layout and specifies the timing-driven option:

```
layout -timing_driven
```

### See Also

[MX, DX, and ACT Layout options](#)

[MX, DX, and ACT Advanced Layout options](#)

## list\_clocks

Returns details about all of the clock constraints in the current timing constraint scenario.

```
list_clocks
```

## Arguments

None

## Supported Families

IGLOO, ProASIC3, SmartFusion, Fusion, ProASIC<sup>PLUS</sup>, ProASIC, Axcelerator, RTAX-S, eX, and SX-A

## Exceptions

None

## Examples

```
puts [list_clocks]
```

### See Also

[create\\_clock](#)

[remove\\_clock](#)

[Tcl documentation conventions](#)

## list\_clock\_latencies

Returns details about all of the clock latencies in the current timing constraint scenario.

```
list_clock_latencies
```

### Arguments

None

### Supported Families

IGLOO, ProASIC3, SmartFusion, Fusion, ProASIC<sup>PLUS</sup>, ProASIC, Axcelerator, RTAX-S, eX, and SX-A

### Exceptions

None

### Examples

```
puts [list_clock_latencies]
```

#### See Also

[set\\_clock\\_latency](#)

[remove\\_clock\\_latency](#)

[Tcl documentation conventions](#)

## list\_clock\_uncertainties

Returns details about all of the clock uncertainties in the current timing constraint scenario.

```
list_clock_uncertainties
```

### Arguments

None

### Supported Families

IGLOO, ProASIC3, SmartFusion, Fusion, ProASIC<sup>PLUS</sup>, ProASIC (for analysis), Axcelerator, RTAX-S, eX (for analysis), SX-A (for analysis)

### Exceptions

None

## Examples

```
list_clock_uncertainties
```

### See Also

[set\\_clock\\_uncertainty](#)

[remove\\_clock\\_uncertainty](#)

## list\_disable\_timings

Returns the list of disable timing constraints for the current scenario.

```
list_disable_timings
```

### Arguments

- None

### Supported Families

IGLOO, ProASIC3, SmartFusion, Fusion, Axcelerator, and RTAX-S

## Exceptions

- None

## Example

```
list_disable_timings
```

## list\_false\_paths

Returns details about all of the false paths in the current timing constraint scenario.

```
list_false_paths
```

## Arguments

None

## Supported Families

IGLOO, ProASIC3, SmartFusion, Fusion, ProASIC<sup>PLUS</sup>, ProASIC, Axcelerator, RTAX-S, eX, and SX-A

## Exceptions

None

## Examples

```
puts [list_false_paths]
```

**See Also**[set\\_false\\_path](#)[remove\\_false\\_path](#)[Tcl documentation conventions](#)

## list\_generated\_clocks

Returns details about all of the generated clock constraints in the current timing constraint scenario.

```
list_generated_clocks
```

**Arguments**

None

**Supported Families**

IGLOO, ProASIC3, SmartFusion, Fusion, ProASIC<sup>PLUS</sup>, ProASIC, Axcelerator, RTAX-S, eX, and SX-A

**Exceptions**

None

**Examples**

```
puts [list_generated_clocks]
```

**See Also**[create\\_generated\\_clock](#)[remove\\_generated\\_clock](#)[Tcl documentation conventions](#)

## list\_input\_delays

Returns details about all of the input delay constraints in the current timing constraint scenario.

```
list_input_delays
```

**Arguments**

None

**Supported Families**

IGLOO, ProASIC3, SmartFusion, Fusion, ProASIC<sup>PLUS</sup>, ProASIC, Axcelerator, RTAX-S, eX, and SX-A

**Exceptions**

None



## Examples

```
puts [list_input_delays]
```

### See Also

[set\\_input\\_delay](#)

[remove\\_input\\_delay](#)

[Tcl documentation conventions](#)

## list\_max\_delays

Returns details about all of the maximum delay constraints in the current timing constraint scenario.

```
list_max_delays
```

## Arguments

None

## Supported Families

IGLOO, ProASIC3, SmartFusion, Fusion, ProASIC<sup>PLUS</sup>, ProASIC, Axcelerator, RTAX-S, eX, and SX-A

## Exceptions

None

## Examples

```
puts [list_max_delays]
```

### See Also

[set\\_max\\_delay](#)

[remove\\_max\\_delay](#)

[Tcl documentation conventions](#)

## list\_min\_delays

Returns details about all of the minimum delay constraints in the current timing constraint scenario.

```
list_min_delays
```

## Arguments

None

## Supported Families

IGLOO, ProASIC3, SmartFusion, Fusion, ProASIC<sup>PLUS</sup>, ProASIC, Axcelerator, RTAX-S, eX, and SX-A

## Exceptions

None

## Examples

```
puts [list_min_delays]
```

### See Also

[set\\_min\\_delay](#)

[remove\\_min\\_delay](#)

[Tcl documentation conventions](#)

## list\_multicycle\_paths

Returns details about all of the multicycle paths in the current timing constraint scenario.

```
list_multicycle_paths
```

## Arguments

None

## Supported Families

IGLOO, ProASIC3, SmartFusion, Fusion, ProASIC<sup>PLUS</sup>, ProASIC, Axcelerator, RTAX-S, eX, and SX-A

## Exceptions

None

## Examples

```
puts [list_multicycle_paths]
```

### See Also

[set\\_multicycle\\_path](#)

[remove\\_multicycle\\_path](#)

[Tcl documentation conventions](#)

## list\_objects

Returns a list of object matching the parameter. Objects can be nets, pins, ports, clocks or instances.

```
list_objects <object>
```

## Arguments

Any timing constraint parameter.

## Supported Families

IGLOO, ProASIC3, SmartFusion, Fusion, and Axcelerator

## Exceptions

None

## Example

The following example lists all the inputs in your design:

```
list_objects [all_inputs]
```

You can also use wildcards to filter your list, as in the following command:

```
list_objects [get_ports a*]
```

### See Also

[Tcl documentation conventions](#)

# list\_output\_delays

Returns details about all of the output delay constraints in the current timing constraint scenario.

```
list_output_delays
```

## Arguments

None

## Supported Families

IGLOO, ProASIC3, SmartFusion, Fusion, ProASIC<sup>PLUS</sup>, ProASIC, Axcelerator, RTAX-S, eX, and SX-A

## Exceptions

None

## Examples

```
puts [list_output_delays]
```

### See Also

[set\\_output\\_delay](#)

[remove\\_output\\_delay](#)

[Tcl documentation conventions](#)

# list\_scenarios

Returns a list of names of all of the available timing scenarios.

```
list_scenarios
```

## Arguments

None

## Supported Families

IGLOO, ProASIC3, SmartFusion, Fusion, ProASIC<sup>PLUS</sup>, ProASIC, Axcelerator, RTAX-S, eX, and SX-A

## Exceptions

None

## Examples

```
list_scenarios
```

### See Also

[get\\_current\\_scenario](#)

[Tcl documentation conventions](#)

## LOGFILE

The LOGFILE command is not a Tcl script. It runs in conjunction with your Tcl script and enables you to specify a filename to which Designer will record/save a copy of the log messages generated in batch-mode (SCRIPT:...).

It is useful if you want to view the log after you run scripts in batch-mode on Windows.

For example, to run the script 'myscript.tcl' for Designer and save the log messages to a LOGFILE named 'mylog.txt', use the command:

```
designer.exe SCRIPT:myscript.tcl LOGFILE:mylog.txt
```

### See Also

[Introduction to Tcl scripting](#)

## new\_design

Creates a new design. You need all three arguments for this command. This command will set up the Designer software for importing design source files

```
new_design -name design_name -family family_name -path pathname-block value
```

## Arguments

-name *design\_name*

The name of the design. This is used as the base name for most of the files generated from Designer.

-family *family\_name*

The Actel device family for which the design is being targeted.

-path *path\_name*

The physical path of the directory in which the design files will be created.

block *value*

Enables or disables Block mode. The following table shows the acceptable values for this option:

Value	Description
on	Enables Block mode
off	Disables Block mode

## Supported Families

All

## Exceptions

None

## Example

Example 1: Creates a new ACT3 design with the name “test” in the current folder.

```
new_design -name "test" -family "ACT3" -path {.}
```

Example 2: These set of commands create a new design through variable substitution.

```
set desName "test"
set famName "ACT3"
set path {d:/examples/test}
new_design -name $desName -family $famName -path $path
```

Example 3: Design creation and catch failures

```
if { [catch { new_design -name $desName -family $famName -path $path }] {
    puts "Failed to create a new design"
    # Handle Failure
} else {
    puts "New design creation successful"
    # Proceed to Import source files
}
```

## See Also

[close\\_design](#)  
[open\\_design](#)  
[save\\_design](#)  
[set\\_design](#)

## open\_design

Opens an existing design into the Designer software.

```
open_design file_name
```

**Note:** Note: >All previously open designs must be closed before opening a new design.

### Arguments

*file\_name*

The complete .adb file path. If the complete path is not provided, then the directory is assumed to be the current working directory.

### Supported Families

All

### Exceptions

- None

### Example

Example 1: Opens an existing design from the file “test.adb” in the current folder.

```
open_design {test.adb}
```

Example 2: Design creation and catch failures.

```
set designFile {d:/test/my_design.adb}
if { [catch { open_design $designFile } ] {
    puts "Failed to open design"
    # Handle Failure
} else {
    puts "Design opened successfully"
    # Proceed to further processing
}
```

### See Also

[close\\_design](#)

[new\\_design](#)

[save\\_design](#)

## pin\_assign

Use to either assign the named pin to the specified port or assign attributes to the specified port. This command has two syntax formats. The one you use depends on what you are trying to do. The first syntax format assigns the named pin to the specified port and supports all families. The second one assigns attributes to the specified port but supports only the ProASIC3, Axcelerator, SX-A, RTSX-S, and eX families.

```
pin_assign [-nofix] -port portname -pin pin_number
```

```
pin_assign -port portname [-iostd value][-iothresh value][-outload value][-slew value][-res_pull value]
```

## Arguments

`-nofix`

Unlocks the pin assignment (by default, assignments are locked).

`-port portname`

Specifies the name of the port to which the pin is assigned.

`-pin pin_number`

Specifies the alphanumeric number of the pin to assign.

`-iostd value`

Sets the I/O standard for this pin. Choosing a standard allows the software to set other attributes such as the slew rate and output loading. If the voltage standard used with the I/O is not compatible with other I/Os in the I/O bank, then assigning an I/O standard to a port will invalidate its location and automatically unassign the I/O. The following table shows the acceptable values for the supported devices:

I/O Standards table

Use the I/O Standards table to see which I/O standards can be applied to each family:

I/O Standard	IGLOO	Fusion	ProASIC3	Axcelerator	RTSX-S	SX-A
CMOS					X	
CUSTOM					X	X
GTL25	IGLOOe only	X	ProASIC3E and ProASIC3L only	X		
GTL33	IGLOOe only	X	ProASIC3E and ProASIC3L only			
GTL33	IGLOOe only	X	ProASIC3E and ProASIC3L only	X		
GTL25	IGLOOe only	X	ProASIC3E and ProASIC3L only	X		
HSTL1	IGLOOe only	X	ProASIC3E and ProASIC3L only	X		
HSTLII	IGLOOe only	X	ProASIC3E and ProASIC3L only			

I/O Standard	IGLOO	Fusion	ProASIC3	Axcelerator	RTSX-S	SX-A
LVC MOS33	X	X	X			
LVC MOS25	IGLOOe only	X	X	X		
LVC MOS25_50	X	X	X			
LVC MOS18	X	X	X	X		
LVC MOS15	X	X	X	X		
LVC MOS12	X		ProASIC3L only			
LVTTL	X	X	X	X	X	X
TTL	X	X	X	X	X	X
PCI	X	X	X	X	X	X
PCIX	X	X	X	X		
SSTL2I	IGLOOe only	X	ProASIC3E and ProASIC3L only	X		
SSTL2II	IGLOOe only	X	ProASIC3E and ProASIC3L only	X		
SSTL3I	IGLOOe only	X	ProASIC3E and ProASIC3L only	X		
SSTL3II	IGLOOe only	X	ProASIC3E and ProASIC3L only	X		

**See Also**

[I/O standard](#)

Note: Note: The LVDS and LVPECL I/O standards cannot be set through a script.



`-iothresh` *value*

Sets the compatible threshold level for inputs and outputs. The default I/O threshold is based upon the I/O standard. You can set the I/O Threshold independently of the I/O specification in the PinEditor tool by selecting **CUSTOM** in the I/O Standard cell. The following table shows the acceptable values for the supported devices (SX-A, RTSX-S, and eX):

Value	Description
CMOS	RTSX-S devices only. An advanced integrated circuit (IC) manufacturing process technology for logic and memory, characterized by high integration, low cost, low power, and high performance. CMOS logic uses a combination of p-type and n-type metal-oxide-semiconductor field effect transistors (MOSFETs) to implement logic gates and other digital circuits found in computers, telecommunications, and signal processing equipment.
LVTTL	(Low-Voltage TTL) A general purpose standard (EIA/JESDSA) for 3.3V applications. It uses an LVTTL input buffer and a push-pull output buffer.
PCI	A computer bus for attaching peripheral devices to a computer motherboard in a local bus. This standard supports both 33 MHz and 66 MHz PCI bus applications. It uses an LVTTL input buffer and a push-pull output buffer. With the aid of an external resistor, this I/O standard can be 5V-compliant for most families, excluding IGLOO, ProASIC3, SmartFusion and Fusion families.

**Note:** Note: The `-iothresh` attribute is also referred to as "Loading" in some families.

`-slew` *value*

Sets the output slew rate. Slew control affects only the falling edges. Rising edges are not affected. This attribute is only available for LVTTL, PCI, and PCI outputs. For LVTTL, it can either be high or low. For PCI and PCIX, it can only be set to high. The following table shows the acceptable values for the supported devices (IGLOO, ProASIC3, SmartFusion, Fusion, ProASIC<sup>PLUS</sup>, ProASIC, Axcelerator, RTAX-S, eX, and SX-A):

Value	Description
high	Sets the I/O slew to high
low	Sets the I/O slew to low

`-res_pull` *value*

Allows you to include a weak resistor for either pull-up or pull-down of the input buffer. The following table shows the acceptable values for the supported devices (IGLOO, ProASIC3, SmartFusion, Fusion, ProASIC<sup>PLUS</sup>, ProASIC, Axcelerator, RTAX-S, eX, and SX-A):

Value	Description
up	Includes a weak resistor for pull-up of the input buffer
down	Includes a weak resistor for pull-down of the input buffer
none	Does not include a weak resistor

`-out_load` *value*

Indicates the output-capacitance value based on the I/O standard selected. This option is not available in software. This attribute determines what Timer will use as the loading on the output pin and applies only to outputs. You can enter a capacitive load as an integral number of picofarads ( $pF$ ). The default is  $35pF$ . This attribute is available only for the following devices: ProASIC3, SmartFusion, Fusion, Axcelerator, SX-A, RTSX-S, and eX.

## Supported Families

The first syntax statement for `pin_assign` supports all families. The second one supports only IGLOO, ProASIC3, SmartFusion, Fusion, ProASIC<sup>PLUS</sup>, ProASIC, Axcelerator, RTAX-S, eX, and SX-A.

## Exceptions

- None

## Examples

You must use `pin_commit` after the `pin_assign` command to save the changes to your design:

```
pin_assign -port usw0 -pin A2
pin_commit
```

```
pin_assign -port usw0 -iostd LVTTTL -slew low -res_pull down
pin_commit
```

**Note:** Note: To use a name with special characters such as square brackets [ ], you must put the entire name between curly braces { } or put a slash character \ immediately before each square bracket as shown in the following examples.

**Note:** The following example shows a port name enclosed with curly braces:

**Note:** The next example shows each square bracket preceded by a slash:

```
pin_assign -port LFSR_OUT\[15\] -iostd lvtttl -slew High
```

## See Also

[pin\\_commit](#)  
[pin\\_fix](#)  
[pin\\_unassign](#)

[Tcl documentation conventions](#)

## pin\_commit

Saves the pin assignments to the design (.adb) file.

```
pin_commit
```

**Note:** Note: You can use this command for designs created with PinEditor in MVN and PinEditor (non-MVN).

### Arguments

- None

### Supported Families

All families

### Exceptions

- None

### Examples

To save pin assignments in your design, you must add the pin\_commit command to the end of the script:

```
pin_commit
```

#### See Also

[pin\\_fix](#)

[pin\\_unfix](#)

[pin\\_assign](#)

[pin\\_unassign](#)

[Tcl documentation conventions](#)

## pin\_fix

Locks the pin assignment for the specified port, so the pins cannot be moved during place-and-route.

```
pin_fix -port portname
```

**Note:** Note: You can use this command for designs created with PinEditor in MVN and PinEditor (non-MVN).

### Arguments

-port *portname*

Specifies the name of the port to which the pin must be locked at its assigned location.

**Note:** Note: You can assign only one pin to a port

## Supported Families

All families

## Description

Fixed pins are locked pins. You cannot move locked pins during place-and-route.

## Exceptions

- None

## Examples

You must use `pin_commit` after the `pin_fix` command to save the changes to your design:

```
pin_fix -port clk
pin_commit
```

### See Also

[pin\\_commit](#)  
[pin\\_unfix](#)  
[pin\\_assign](#)  
[pin\\_unassign](#)  
[Tcl documentation conventions](#)

## pin\_fix\_all

Locks all the assigned pins on the device so they cannot be moved during place-and-route.

```
pin_fix_all
```

**Note:** Note: You can use this command for designs created with PinEditor in MVN and PinEditor (non-MVN).

## Arguments

- None

## Supported Families

All families

## Description

Fixed pins are locked pins. This command locks all the pins in your design. You cannot move locked pins during place-and-route.

## Exceptions

- None

## Example

You must use `pin_commit` after the `pin_fix_all` command to save the changes to your design:

```
pin_fix_all
pin_commit
```

### See Also

[pin\\_commit](#)  
[pin\\_fix](#)  
[pin\\_unfix](#)  
[pin\\_assign](#)  
[pin\\_unassign](#)  
[Tcl documentation conventions](#)

## pin\_unassign

Unassigns the pin from the specified port. The unassigned pin location is then available for other ports. (Only one pin can be assigned to a port.)

```
pin_unassign -port portname
```

**Note:** Note: You can use this command for designs created with PinEditor in MVN and PinEditor (non-MVN).

## Arguments

-port *portname*

Specifies the name of the port for which the pin must be unassigned.

## Supported Families

All

## Exceptions

- None

## Examples

You must use `pin_commit` after the `pin_assign` command to save the changes to your design:

```
pin_unassign -port "clk"
pin_commit
```

### See Also

[pin\\_commit](#)  
[pin\\_fix](#)  
[pin\\_fix\\_all](#)  
[pin\\_unfix](#)  
[pin\\_assign](#)  
[pin\\_unassign](#)

[Tcl documentation conventions](#)

## pin\_unassign\_all

Unassigns all the pins from all the ports so that all pin locations are available for assignment.

```
pin_unassign_all
```

**Note:** Note: You can use this command for designs created with PinEditor in MVN and PinEditor (non-MVN).

### Arguments

- None

### Supported Families

All families

### Exceptions

- None

### Examples

You must use `pin_commit` after the `pin_assign_all` command to save the changes to your design:

```
pin_unassign_all
pin_commit
```

#### See Also

[pin\\_commit](#)  
[pin\\_fix](#)  
[pin\\_unfix](#)  
[pin\\_assign](#)  
[pin\\_unassign](#)  
[Tcl documentation conventions](#)

## pin\_unfix

Unlocks the pins assigned to the specified port, so the pins can be moved during place-and-route.

```
pin_unfix -port portname
```

**Note:** Note: You can use this command for designs created with PinEditor in MVN and PinEditor (non-MVN).

### Arguments

`-port portname`  
Specifies the name of the port containing pins to unlock.

## Supported Families

All families

## Exceptions

None

## Examples

You must use `pin_commit` command after the `pin_unfix` command to save the changes to your design:

```
pin_unfix -port rst
pin_commit
```

### See Also

[pin\\_commit](#)  
[pin\\_fix](#)  
[pin\\_assign](#)  
[pin\\_unassign](#)  
[Tcl documentation conventions](#)

## remove\_clock

Removes the specified clock constraint from the current timing scenario.

```
remove_clock {-name clock_name | -id constraint_ID}
```

## Arguments

-name *clock\_name*

Specifies the name of the clock constraint to remove from the current scenario. You must specify either a clock name or an ID.

-id *constraint\_ID*

Specifies the ID of the clock constraint to remove from the current scenario. You must specify either an ID or a clock name that exists in the current scenario.

## Supported Families

IGLOO, ProASIC3, SmartFusion, Fusion, ProASIC<sup>PLUS</sup>, ProASIC (for analysis), Axcelerator, RTAX-S,eX, and SX-A

## Description

Removes the specified clock constraint from the current scenario. If the specified name does not match a clock constraint in the current scenario, or if the specified ID does not refer to a clock constraint, this command fails.

Do not specify both the name and the ID.

## Exceptions

- You cannot use wildcards when specifying a clock name.

## Examples

The following example removes the clock constraint named "my\_user\_clock":

```
remove_clock -name my_user_clock
```

The following example removes the clock constraint using its ID:

```
set clockId [create_clock -name my_user_clock -period 2]
remove_clock -id $clockId
```

### See Also

[create\\_clock](#)

[Tcl Command Documentation Conventions](#)

## remove\_clock\_latency

Removes a clock source latency from the specified clock and from all edges of the clock.

```
remove_clock_latency {-source clock_name_or_source |-id constraint_ID}
```

## Arguments

-source *clock\_name\_or\_source*

Specifies either the clock name or source name of the clock constraint from which to remove the clock source latency. You must specify either a clock or source name or its constraint ID.

-id *constraint\_ID*

Specifies the ID of the clock constraint to remove from the current scenario. You must specify either a clock or source name or its constraint ID.

## Supported Families

IGLOO, ProASIC3, SmartFusion, Fusion, ProASIC<sup>PLUS</sup>, ProASIC (for analysis), Axcelerator, RTAX-S,eX, and SX-A

## Description

Removes a clock source latency from the specified clock in the current scenario. If the specified source does not match a clock with a latency constraint in the current scenario, or if the specified ID does not refer to a clock with a latency constraint, this command fails.

Do not specify both the source and the ID.

## Exceptions

- You cannot use wildcards when specifying a clock name.



## Examples

The following example removes the clock source latency from the specified clock.

```
remove_clock_latency -source my_clock
```

### See Also

[set\\_clock\\_latency](#)

[Tcl Command Documentation Conventions](#)

## remove\_clock\_uncertainty

Removes a clock-to-clock uncertainty from the current timing scenario by specifying either its exact arguments or its ID.

```
remove_clock_uncertainty -from | -rise_from | -fall_from from_clock_list -to | -rise_to | -fall_to to_clock_list -setup {value} -hold {value}
remove_clock_uncertainty -id constraint_ID
```

## Arguments

**-from**

Specifies that the clock-to-clock uncertainty applies to both rising and falling edges of the source clock list. Only one of the **-from**, **-rise\_from**, or **-fall\_from** arguments can be specified for the constraint to be valid.

**-rise\_from**

Specifies that the clock-to-clock uncertainty applies only to rising edges of the source clock list. Only one of the **-from**, **-rise\_from**, or **-fall\_from** arguments can be specified for the constraint to be valid.

**-fall\_from**

Specifies that the clock-to-clock uncertainty applies only to falling edges of the source clock list. Only one of the **-from**, **-rise\_from**, or **-fall\_from** arguments can be specified for the constraint to be valid.

***from\_clock\_list***

Specifies the list of clock names as the uncertainty source.

**-to**

Specifies that the clock-to-clock uncertainty applies to both rising and falling edges of the destination clock list. Only one of the **-to**, **-rise\_to**, or **-fall\_to** arguments can be specified for the constraint to be valid.

**-rise\_to**

Specifies that the clock-to-clock uncertainty applies only to rising edges of the destination clock list. Only one of the **-to**, **-rise\_to**, or **-fall\_to** arguments can be specified for the constraint to be valid.

**-fall\_to**

Specifies that the clock-to-clock uncertainty applies only to falling edges of the destination clock list. Only one of the **-to**, **-rise\_to**, or **-fall\_to** arguments can be specified for the constraint to be valid.

***to\_clock\_list***

Specifies the list of clock names as the uncertainty destination.

**-setup**

Specifies that the uncertainty applies only to setup checks. If none or both **-setup** and **-hold** are present, the uncertainty applies to both setup and hold checks.

**-hold**

Specifies that the uncertainty applies only to hold checks. If none or both `-setup` and `-hold` are present, the uncertainty applies to both setup and hold checks.

`-id constraint_ID`

Specifies the ID of the clock constraint to remove from the current scenario. You must specify either the exact parameters to set the constraint or its constraint ID.

## Supported Families

IGLOO, ProASIC3, SmartFusion, Fusion, ProASIC<sup>PLUS</sup>, ProASIC (for analysis), Axcelerator, RTAX-S, eX (for analysis), SX-A (for analysis)

## Description

Removes a clock-to-clock uncertainty from the specified clock in the current scenario. If the specified arguments do not match clocks with an uncertainty constraint in the current scenario, or if the specified ID does not refer to a clock-to-clock uncertainty constraint, this command fails.

Do not specify both the exact arguments and the ID.

## Exceptions

- None

## Examples

```
remove_clock_uncertainty -from Clk1 -to Clk2
remove_clock_uncertainty -from Clk1 -fall_to { Clk2 Clk3 } -setup
remove_clock_uncertainty 4.3 -fall_from { Clk1 Clk2 } -rise_to *
remove_clock_uncertainty 0.1 -rise_from [ get_clocks { Clk1 Clk2 } ] -fall_to { Clk3
Clk4 } -setup
remove_clock_uncertainty 5 -rise_from Clk1 -to [ get_clocks {*} ]
remove_clock_uncertainty -id $clockId
```

### See Also

[remove\\_clock](#)  
[remove\\_generated\\_clock](#)  
[set\\_clock\\_uncertainty](#)

## remove\_disable\_timing

Removes a disable timing constraint by specifying its arguments, or its ID. If the arguments do not match a disable timing constraint, or if the ID does not refer to a disable timing constraint, the command fails.

```
remove_disable_timing -from value -to value name -id name
```

## Arguments

`-from from_port`

Specifies the starting port. The `-from` and `-to` arguments must either both be present or both omitted for the constraint to be valid.

-to *to\_port*

Specifies the ending port. The -from and -to arguments must either both be present or both omitted for the constraint to be valid.

*name*

Specifies the cell name where the disable timing constraint will be removed. It is an error to supply both a cell name and a constraint ID, as they are mutually exclusive. No wildcards are allowed when specifying a clock name, either alone or in an accessor command1.

-id *name*

Specifies the constraint name where the disable timing constraint will be removed. It is an error to supply both a cell name and a constraint ID, as they are mutually exclusive. No wildcards are allowed when specifying a clock name, either alone or in an accessor command1.

## Supported Families

IGLOO, ProASIC3, SmartFusion, Fusion, Axcelerator, and RTAX-S

## Exceptions

- None

## Example

```
remove_disable_timing -from port1 -to port2 -id new_constraint
```

## remove\_false\_path

Removes a false path from the current timing scenario by specifying either its exact arguments or its ID.

```
remove_false_path [-from from_list] [-to to_list] [-through through_list] [-id constraint_ID]
remove_false_path -id constraint_ID
```

## Arguments

-from *from\_list*

Specifies a list of timing path starting points. A valid timing starting point is a clock, a primary input, an inout port, or a clock pin of a sequential cell.

-through *through\_list*

Specifies a list of pins, ports, cells, or nets through which the disabled paths must pass.

-to *to\_list*

Specifies a list of timing path ending points. A valid timing ending point is a clock, a primary output, an inout port, or a data pin of a sequential cell.

-id *constraint\_ID*

Specifies the ID of the false path constraint to remove from the current scenario. You must specify either the exact false path to remove or the constraint ID that refers to the false path constraint to remove.

## Supported Families

IGLOO, ProASIC3, SmartFusion, Fusion, ProASIC<sup>PLUS</sup>, ProASIC (for analysis), Axcelerator, RTAX-S, eX (-through option), and SX-A (-through option)

## Description

Removes a false path from the specified clock in the current scenario. If the arguments do not match a false path constraint in the current scenario, or if the specified ID does not refer to a false path constraint, this command fails.

Do not specify both the false path arguments and the constraint ID.

## Exceptions

- You cannot use wildcards when specifying a clock name, either alone or in an Accessor command such as `get_pins` or `get_ports`.

## Examples

The following example specifies all false paths to remove:

```
remove_false_path -through U0/U1:Y
```

The following example removes the false path constraint using its id:

```
set fpId [set_false_path -from [get_clocks c*] -through {topx/reg/*} -to [get_ports out15] ]
remove_false_path -id $fpId
```

### See Also

[set\\_false\\_path](#)

[Tcl Command Documentation Conventions](#)

## remove\_generated\_clock

Removes the specified generated clock constraint from the current scenario.

```
remove_generated_clock {-name clock_name | -id constraint_ID }
```

## Arguments

-name *clock\_name*

Specifies the name of the generated clock constraint to remove from the current scenario. You must specify either a clock name or an ID.

-id *constraint\_ID*

Specifies the ID of the generated clock constraint to remove from the current scenario. You must specify either an ID or a clock name that exists in the current scenario.

## Supported Families

IGLOO, ProASIC3, SmartFusion, Fusion, ProASIC<sup>PLUS</sup>, ProASIC (for analysis), Axcelerator, RTAX-S,eX, and SX-A

## Description

Removes the specified generated clock constraint from the current scenario. If the specified name does not match a generated clock constraint in the current scenario, or if the specified ID does not refer to a generated clock constraint, this command fails.

Do not specify both the name and the ID.

## Exceptions

- You cannot use wildcards when specifying a generated clock name.

## Examples

The following example removes the generated clock constraint named "my\_user\_clock":

```
remove_generated_clock -name my_user_clock
```

### See Also

[create\\_generated\\_clock](#)

[Tcl Command Documentation Conventions](#)

## remove\_input\_delay

Removes an input delay a clock on a port by specifying both the clocks and port names or the ID of the input\_delay constraint to remove.

```
remove_input_delay -clock clock_name port_pin_list  
remove_input_delay -id constraint_ID
```

## Arguments

-clock *clock\_name*

Specifies the clock name to which the specified input delay value is assigned.

*port\_pin\_list*

Specifies the port names to which the specified input delay value is assigned.

-id *constraint\_ID*

Specifies the ID of the clock with the input\_delay value to remove from the current scenario. You must specify either both a clock name and list of port names or the input\_delay constraint ID .

## Supported Families

IGLOO, ProASIC3, SmartFusion, Fusion, ProASIC<sup>PLUS</sup>, ProASIC, Axcelerator, RTAX-S, eX (for analysis), and SX-A (for analysis)

## Description

Removes an input delay from the specified clocks and port in the current scenario. If the clocks and port names do not match an input delay constraint in the current scenario, or if the specified ID does not refer to an input delay constraint, this command fails.

Do not specify both the clock and port names and the constraint ID.

## Exceptions

- You cannot use wildcards when specifying a clock name, either alone or in an accessor command.

## Examples

The following example removes the input delay from CLK1 on port data1:

```
remove_input_delay -clock [get_clocks CLK1] [get_ports data1]
```

### See Also

[set\\_input\\_delay](#)

[Tcl Command Documentation Conventions](#)

## remove\_library

Removes a VHDL library from your project.

```
remove_library  
-library name
```

## Arguments

-library *name*

Specifies the name of the library you wish to remove.

## Supported Families

All

## Exceptions

- None

## Example

Remove (delete) a library called 'my\_lib'.

```
remove_library -library my_lib
```

### See Also

[add\\_library](#)

[rename\\_library](#)

## remove\_max\_delay

Removes a maximum delay constraint from the current timing scenario by specifying either its exact arguments or its ID.

```
remove_max_delay [-from from_list] [-to to_list] [-through through_list]  
remove_max_delay -id constraint_ID
```

### Arguments

-from *from\_list*

Specifies a list of timing path starting points. A valid timing starting point is a clock, a primary input, an inout port, or a clock pin of a sequential cell.

-through *through\_list*

Specifies a list of pins, ports, cells, or nets through which the disabled paths must pass.

-to *to\_list*

Specifies a list of timing path ending points. A valid timing ending point is a clock, a primary output, an inout port, or a data pin of a sequential cell.

-id *constraint\_ID*

Specifies the ID of the maximum delay constraint to remove from the current scenario. You must specify either the exact maximum delay arguments to remove or the constraint ID that refers to the maximum delay constraint to remove.

### Supported Families

IGLOO, ProASIC3, SmartFusion, Fusion, ProASIC<sup>PLUS</sup>, ProASIC (for analysis), Axcelerator, RTAX-S, eX (-through option), and SX-A (-through option)

### Description

Removes a maximum delay value from the specified clock in the current scenario. If the arguments do not match a maximum delay constraint in the current scenario, or if the specified ID does not refer to a maximum delay constraint, this command fails.

Do not specify both the maximum delay arguments and the constraint ID.

### Exceptions

- You cannot use wildcards when specifying a clock name, either alone or in an Accessor command.

### Examples

The following example specifies a range of maximum delay constraints to remove:

```
remove_max_delay -through U0/U1:Y
```

### See Also

[set\\_max\\_delay](#)

[Tcl Command Documentation Conventions](#)

## remove\_min\_delay

Removes a minimum delay constraint in the current timing scenario by specifying either its exact arguments or its ID.

```
remove_min_delay [-from from_list] [-to to_list] [-through through_list]  
remove_min_delay -id constraint_ID
```

### Arguments

-from *from\_list*

Specifies a list of timing path starting points. A valid timing starting point is a clock, a primary input, an inout port, or a clock pin of a sequential cell.

-through *through\_list*

Specifies a list of pins, ports, cells, or nets through which the disabled paths must pass.

-to *to\_list*

Specifies a list of timing path ending points. A valid timing ending point is a clock, a primary output, an inout port, or a data pin of a sequential cell.

-id *constraint\_ID*

Specifies the ID of the minimum delay constraint to remove from the current scenario. You must specify either the exact minimum delay arguments to remove or the constraint ID that refers to the minimum delay constraint to remove.

### Supported Families

IGLOO, ProASIC3, SmartFusion, Fusion, ProASIC<sup>PLUS</sup>, ProASIC (for analysis), Axcelerator, RTAX-S, eX (-through option), and SX-A (-through option)

### Description

Removes a minimum delay value from the specified clock in the current scenario. If the arguments do not match a minimum delay constraint in the current scenario, or if the specified ID does not refer to a minimum delay constraint, this command fails.

Do not specify both the minimum delay arguments and the constraint ID.

### Exceptions

- You cannot use wildcards when specifying a clock name, either alone or in an accessor command.

### Examples

The following example specifies a range of minimum delay constraints to remove:

```
remove_min_delay -through U0/U1:Y
```

### See Also

[set\\_min\\_delay](#)

[Tcl Command Documentation Conventions](#)



## remove\_multicycle\_path

Removes a multicycle path constraint in the current timing scenario by specifying either its exact arguments or its ID.

```
remove_multicycle_path [-from from_list] [-to to_list] [-through through_list]  
remove_multicycle_path -id constraint_ID
```

### Arguments

-from *from\_list*

Specifies a list of timing path starting points. A valid timing starting point is a clock, a primary input, an inout port, or a clock pin of a sequential cell.

-through *through\_list*

Specifies a list of pins, ports, cells, or nets through which the disabled paths must pass.

-to *to\_list*

Specifies a list of timing path ending points. A valid timing ending point is a clock, a primary output, an inout port, or a data pin of a sequential cell.

-id *constraint\_ID*

Specifies the ID of the multicycle path constraint to remove from the current scenario. You must specify either the exact multicycle path arguments to remove or the constraint ID that refers to the multicycle path constraint to remove.

### Supported Families

IGLOO, ProASIC3, SmartFusion, Fusion, ProASIC<sup>PLUS</sup>, ProASIC (for analysis), Axcelerator, RTAX-S, eX (for analysis), SX-A (for analysis)

### Description

Removes a multicycle path from the specified clock in the current scenario. If the arguments do not match a multicycle path constraint in the current scenario, or if the specified ID does not refer to a multicycle path constraint, this command fails.

Do not specify both the multicycle path arguments and the constraint ID.

### Exceptions

- You cannot use wildcards when specifying a clock name, either alone or in an accessor command.

### Examples

The following example removes all paths between reg1 and reg2 to 3 cycles for setup check.

```
remove_multicycle_path -from [get_pins {reg1}] -to [get_pins {reg2}]
```

### See Also

[set\\_multicycle\\_path](#)

[Tcl Command Documentation Conventions](#)

## remove\_output\_delay

Removes an output delay by specifying both the clocks and port names or the ID of the output\_delay constraint to remove.

```
remove_output_delay -clock clock_name port_pin_list
remove_output_delay -id constraint_ID
```

### Arguments

-clock *clock\_name*

Specifies the clock name to which the specified output delay value is assigned.

*port\_pin\_list*

Specifies the port names to which the specified output delay value is assigned.

-id *constraint\_ID*

Specifies the ID of the clock with the output\_delay value to remove from the current scenario. You must specify either both a clock name and list of port names or the output\_delay constraint ID .

### Supported Families

IGLOO, ProASIC3, SmartFusion, Fusion, ProASIC<sup>PLUS</sup>, ProASIC (for analysis), Axcelerator, RTAX-S, eX (for analysis), SX-A (for analysis)

### Description

Removes an output delay from the specified clocks and port in the current scenario. If the clocks and port names do not match an output delay constraint in the current scenario, or if the specified ID does not refer to an output delay constraint, this command fails.

Do not specify both the clock and port names and the constraint ID.

### Exceptions

- You cannot use wildcards when specifying a clock name, either alone or in an accessor command.

### Examples

The following example removes the output delay from CLK1 on port out1:

```
remove_output_delay -clock [get_clocks CLK1] [get_ports out1]
```

#### See Also

[set\\_output\\_delay](#)

[Tcl Command Documentation Conventions](#)

## rename\_library

Renames a VHDL library in your project.

```
rename_library  
-library name  
-name name
```

## Arguments

-library *name*

Identifies the current name of the library that you wish to rename.

-name *name*

Specifies the new name of the library.

## Supported Families

All

## Exceptions

- None

## Example

Rename a library from 'my\_lib' to 'test\_lib1'

```
rename_library -library my_lib -name test_lib1
```

### See Also

[add\\_library](#)

[remove\\_library](#)

## rename\_scenario

Renames the specified timing scenario with the new name provided. You must provide a unique new name (that is, it cannot already be used by another timing scenario).

```
rename_scenario oldname -new newname
```

## Arguments

*oldname*

Specifies the current name of the timing scenario.

-new *newname*

Specifies the new name to give to the timing scenario.

## Supported Families

IGLOO, ProASIC3, SmartFusion, Fusion, Axcelerator, and RTAX-S

## Description

This command changes the name of the timing scenario in the list of scenarios.

## Example

```
rename_scenario scenario_A -new scenario_B
```

### See Also

[create\\_scenario](#)

[delete\\_scenario](#)

[Tcl documentation conventions](#)

## report

The report command provides you with frequently-used information in a convenient format.

You can generate several different types of reports using this command, including:

- [report \(Status\)](#)
- [report \(Timing\)](#) using Timer; for the SX, MX, 3200DX and ACT families
- [report \(Timing violations\)](#) using Timer; for the SX, MX, 3200DX and ACT families
- [report \(Timing\)](#) using SmartTime; for IGLOO, ProASIC3, SmartFusion, Fusion, ProASIC<sup>PLUS</sup>, ProASIC, Axcelerator, eX, and SX-A families
- [report \(Timing violations\)](#) using SmartTime; for IGLOO, ProASIC3, SmartFusion, Fusion, ProASIC<sup>PLUS</sup>, ProASIC, Axcelerator, eX, and SX-A families
- [report \(Pin\)](#)
- [report \(Flip-flop\)](#)
- [report \(I/O Bank\)](#)
- [report \(Global Usage\)](#)
- [report \(Power\)](#)

## report (Bottleneck) using SmartTime

Creates a bottleneck report.

```
report -type bottleneck
[-cost_type {value} ]
[-use_slack_threshold{value} ]
[-slack_threshold {value} ]
[-set_name {value} ]
[-clock clock_id -set_type value ]
[-source_clock clock_id -sink_clock clock_id]
[-source {pin_list} ]
[-sink {pin_list} ]
[-max_instances {value} ]
[-max_paths {value} ]
[-max_parallel_paths {value} ]
[-analysis_type {value} ]
```

```
{filename} \
[-format value]
```

## Arguments

`-cost_type value`

Specifies the type of bottleneck cost. The default option is `path_count`.

Value	Description
<code>path_count</code>	Instances with the greatest number of path violations will have the highest bottleneck cost
<code>path_cost</code>	Instances with the largest combined timing violations will have the highest bottleneck cost

`-use_slack_threshold value`

Specifies whether to consider the slack threshold when computing the bottlenecks in the report.

Value	Description
<code>yes</code>	Includes slack threshold in the bottleneck report
<code>no</code>	Excludes slack threshold in the bottleneck report

`-slack_threshold value`

Specifies that paths whose slack is larger than this given threshold will be considered. Only instances that lie on these violating paths are reported. The default option is 0.

`-set_name value`

Displays the bottleneck information for the named set. You can either use this option or use both `-clock` and `-type`. This option allows pruning based on a given set. Only paths that lie within the named set will be considered towards bottleneck.

`-clock value`

This option allows pruning based on a given clock domain. Only instances that lie on these violating paths are reported.

`-set_type value`

This option can only be used in combination with the `-clock` option, and not by itself. The options allow to filter which type of paths should be considered towards the bottleneck.

Value	Description
<code>reg_to_reg</code>	Paths between registers in the design
<code>async_to_reg</code>	Paths from asynchronous pins to registers
<code>reg_to_async</code>	Paths from registers to asynchronous pins

Value	Description
external_recovery	The set of paths from inputs to asynchronous pins
external_removal	The set of paths from inputs to asynchronous pins
external_setup	Paths from input ports to registers
external_hold	Paths from input ports to registers
clock_to_out	Paths from registers to output ports

`-source_clock` *clock\_id*

Reports only bottleneck instances that lie on violating timing paths of the inter-clock domain that starts at the source clock specified by this option. This option can only be used in combination with `-sink_clock`, and not by itself.

`-sink_clock` *clock\_id*

Reports only bottleneck instances that lie on violating timing paths of the inter-clock domain that ends at the sink clock specified by this option. This option can only be used in combination with `-source_clock`, and not by itself.

`-source` *value*

Reports only instances that lie on violating paths that start at locations specified by this option.

`-sink` *value*

Reports only instances that lie on violating paths that end at locations specified by this option.

`-max_instances` *value*

Specifies the maximum number of instances to be reported. Defaults to 10.

`-max_paths` *value*

Specifies the maximum number of paths to be considered per path set type. Allowed values are 1 to 2000000. Defaults to 100.

`-max_parallel_paths` *value*

Specifies the maximum number of paths allowed per end point pair. Only instances that lie on these violating paths are reported. Defaults to 1 (No parallel paths).

`-analysis_type` *value*

Specifies the analysis types (max or min) under which the violations are reported. Defaults to max analysis.

Value	Description
max_delay	Sets the analysis type to maximum delay
min_delay	Sets the analysis type to minimum delay

`-format` *value*

Specifies the output format of the generated report.

Value	Description
text	Generates a text report; text is the default value

Value	Description
csv	Generates the report in a comma-separated value format that you can import into a spreadsheet

*filename*

Specifies the name and destination of the bottleneck report.

## Supported Families

IGLOO, ProASIC3, SmartFusion, Fusion, ProASIC<sup>PLUS</sup>, ProASIC, Axcelerator, and SX-A

## Exceptions

None

## Examples

The following example generates a bottleneck report named bottleneck.txt.

```
report -type bottleneck -cost-type path_count -slack_threshold 0 -set_name set1 -
max_cells 10 -max_paths 10 -max_parallel_paths 10 -analysis_type max -format text
bottleneck.txt
```

## See Also

[Tcl documentation conventions](#)

## report (Cycle Accurate Power Report)

Creates a cycle accurate power report, which reports a power waveform with one power value per clock period or half-period instead of an average power for the whole simulation.

```
report -type power_peak_analyzer \
[-vcd_file {path}] \
[-style {value}] \
[-partial_parse {value}] \
[-start_time {value}] \
[-end_time {value}] \
[-auto_detect_top_level_name {value}] \
[-top_level_name {name}] \
[-glitch_filtering {value}] \
[-glitch_threshold {value}] \
[-auto_detect_sampling_period {value}] \
[-sampling_clock { }] \
[-sampling_rate_per_period {value}] \
[-sampling_offset {value}] \
[-sampling_period {value}] \
[-use_only_local_extrema {value}] \
[-use_power_threshold {value}] \
[-power_threshold {value}] \
```

```
[-opmode {value}] \
{filename}
```

## Arguments

`-type power_peak_analyzer`

Specifies the type of report to generate is a cycle accurate power report.

`-vcd_file {path}`

Specifies the path to the \*.vcd file that you want to import.

`-style {value}`

Specifies the format in which the report will be exported. The following table shows the acceptable values for this argument:

Value	Description
Text	The report will be exported as Text file
CSV	The report will be exported as CSV file

`-partial_parse {value}`

Specifies whether to partially parse the \*.vcd file. The following table shows the acceptable values for this argument:

Value	Description
true	Partially parses the *.vcd file
false	Does not partially parse the *.vcd file

`-start_time {value}`

This option is available only if `-partially_parse` is set to `true`. Specifies the start time (in ns) to partially parse the \*.vcd file.

`-end_time {value}`

This option is available only if `-partially_parse` is set to `true`. Specifies the end time (in ns) to partially parse the \*.vcd file.

`-auto_detect_top_level_name {value}`

Specifies whether to automatically detect the top-level name. The following table shows the acceptable values for this argument:

Value	Description
true	Automatically detects the top-level name
false	Does not automatically detect the top-level name

`-top_level_name {name}`

Specifies the top-level name.



`-glitch_filtering {value}`

Specifies whether to use glitch filtering. The following table shows the acceptable values for this argument:

Value	Description
true	Glitch filtering is on
auto	Enables automatic glitch filtering. This option will ignore any value specified in <code>-glitch_threshold</code>
false	Glitch filtering is off

`-glitch_threshold {value}`

This option is only available when `-glitch_filtering` is set to `true`. Specifies the glitch filtering value (in ps).

`-power_summary {value}`

Specifies whether to include the power summary, which shows the static and dynamic values in the report. The following table shows the acceptable values for this argument:

Value	Description
true	Includes the power summary in the report
false	Does not include the power summary in the report

`-auto_detect_sampling_period {value}`

Specifies whether to automatically detect the sampling period. The following table shows the acceptable values for this argument:

Value	Description
true	Automatically detects the sampling period
false	Does not automatically detect the sampling period

`-sampling_clock {}`

Specifies the sampling clock.

`-sampling_rate_per_period {value}`

Specifies whether to set the sampling rate per period. The following table shows the acceptable values for this argument:

Value	Description
true	Specifies the sampling rate per period
false	Specifies the sampling rate per half period

`-sampling_offset {value}`

Specifies the offset used to calculate the sampling offset (in ps).

`-sampling_period {value}`

Specifies the offset used to calculate the sampling period (in ps).

`-use_only_local_extrema {value}`

Specifies whether to limit the history size by keeping only local extrema. The following table shows the acceptable values for this argument:

Value	Description
true	Limits the history size by keeping only local extrema
false	Does not limit the history size by keeping only local extrema

`-use_power_threshold {value}`

Specifies whether to limit the history size by setting a power threshold. The following table shows the acceptable values for this argument:

Value	Description
true	Limits the history size by setting a power threshold
false	Does not limit the history size by setting a power threshold

`-power_threshold {value}`

Sets the power threshold value.

`-opmode {value}`

Use this option to specify the mode from which the operating conditions are extracted to generate the report.

`{filename}`

Specifies the name of the report.

## Supported Families

IGLOO, ProASIC3, SmartFusion, Fusion, ProASIC<sup>PLUS</sup>, ProASIC, and Axcelerator

## Notes

- None

## Exceptions

- None

## Examples

This example generates a cycle accurate power report named `report_power_cycle_based.txt`.

```
report -type "power_cycle_based" -vcd_file "D:/FPU/mul.vcd" -style "Text" -partial_parse
"TRUE" -start_time "0.05" -end_time "1.00" -auto_detect_top_level_name "TRUE" -
glitch_filtering "FALSE" -glitch_threshold "100" -auto_detect_sampling_period "TRUE" -
sampling_clock "clk" -sampling_rate_per_period "TRUE" -sampling_offset "0.00" -
sampling_period "10000.00" -use_only_local_extrema "TRUE" -use_power_threshold "TRUE" -
power_threshold "0.00" -opmode "Active" \ {D:/FPU/report_power_cycle_based.txt}
```

## report (Datasheet) using SmartTime

Creates a datasheet report.

```
report -type datasheet filename \
[-format value]
```

### Arguments

*filename*

Specifies the name and destination of the datasheet report.

-format *value*

Specifies the output format of the generated the report.

Value	Description
text	Generates a text report; text is the default value
csv	Generates the report in a comma-separated value format which you can import into a spreadsheet

### Supported Families

IGLOO, ProASIC3, SmartFusion, Fusion, ProASIC<sup>PLUS</sup>, ProASIC, Axcelerator, eX, and SX-A

### Exceptions

None

### Examples

The following example generates a datasheet report named datasheet.txt.

```
report -type datasheet -format Text datasheet.txt
```

### See Also

[Tcl documentation conventions](#)

[report \(Timing\) using SmartTime](#)

[report \(Timing violations\) using SmartTime](#)

## report (Power Scenario)

Creates a scenario power report for a previously defined scenario. It includes information about the global device and SmartPower preferences selection, and the average power consumption and the expected battery life for this sequence.

```
report -type power_scenario \
[-powerunit {value}] \
[-frequnit {value}] \
[-opcond {value}] \
[-toggle {value}] \
[-scenario {value}] \
[-style {value}] \
[-battery_life {value}] \
[-battery_capacity {value}] \
[-rail_breakdown {value}] \
[-type_breakdown {value}] \
[-mode_breakdown {value}] \
[-opcond_summary {value}] \
{filename}
```

### Arguments

`-type power_scenario`

Specifies the type of report to generate is a scenario power report.

`-powerunit {value}`

Specifies the unit in which power is set. The following table shows the acceptable values for this argument:

Value	Description
W	The power unit is set to watts
mW	The power unit is set to milliwatts
uW	The power unit is set to microwatts

`-frequnit {value}`

Specifies the unit in which frequency is set. The following table shows the acceptable values for this argument:

Value	Description
Hz	The frequency unit is set to hertz
kHz	The frequency unit is set to kilohertz
MHz	The frequency unit is set to megahertz

`-toggle {value}`

Specifies the toggle. The following table shows the acceptable values for this argument:

Value	Description
true	The toggle is set to true
false	The toggle is set to false

`-scenario{value}`

Specifies a scenario that the report is generated from.

`-style {value}`

Specifies the format in which the report will be exported. The following table shows the acceptable values for this argument:

Value	Description
Text	The report will be exported as Text file
CSV	The report will be exported as CSV file

`-battery_life {value}`

Specifies whether to include the battery life summary in the report. The following table shows the acceptable values for this argument:

Value	Description
true	Includes the battery life summary in the report
false	Does not include the battery life summary in the report

`-battery_capacity {value}`

Specifies the battery capacity in A\*H.

`-rail_breakdown {value}`

Specifies whether to include the breakdown by rail summary in the report. The following table shows the acceptable values for this argument:

Value	Description
true	Includes the breakdown by rail summary in the report
false	Does not include the breakdown by rail summary in the report. This is the default value.

`-type_breakdown {value}`

Specifies whether to include the breakdown by type summary in the report. The following table shows the acceptable values for this argument:

Value	Description
true	Includes the breakdown by type summary in the report
false	Does not include the breakdown by type summary in the report. This is the default value.

`-mode_breakdown {value}`

Specifies whether to include a breakdown by mode in the report. The following table shows the acceptable values for this argument:

Value	Description
true	Includes the breakdown by mode in the report
false	Does not include the breakdown by mode in the report. This is the default value.

`-opcond_summary {value}`

Specifies whether to include the operating conditions summary in the report. The following table shows the acceptable values for this argument:

Value	Description
true	Includes the operating conditions summary in the report
false	Does not include the operating conditions summary in the report

`{filename.rpt}`

Specifies the name of the report.

## Supported Families

IGLOO, ProASIC3, SmartFusion, Fusion, ProASIC<sup>PLUS</sup>, ProASIC, and Axcelerator

## Notes

- Flash\*Freeze, Sleep, and Shutdown are available only for certain families and devices.
- Worst and Best are available only for certain families and devices.

## Exceptions

- None

## Examples

This example generates a scenario power report named report.txt for my\_scenario

```
report -type power_scenario -scenario my_scenario -rail_breakdown true -type_breakdown
true -mode_breakdown true -style text -battery_capacity 10 report.txt
```

### See Also

[Scenario Power Report](#)

## report (Timing) using SmartTime

Creates a timing report.

```
report -type timing filename\
[-print_summary value]\
[-analysis value]\
[-use_slack_threshold value]\
[-slack_threshold value]\
[-print_paths value]\
[-max_paths value]\
[-max_expanded_paths value]\
[-include_user_sets value]\
[-include_pin_to_pin value]\
[-include_clock_domains value]\
[-select_clock_domains value]\
[-clock_domain clock_domain_list]\
[-format value]
```

## Arguments

*filename*

Specifies the name and destination of the timing report.

-type timing

Specifies the type of report to generate.

-print\_summary *value*

Specifies whether to print the summary section in the timing report.

Value	Description
yes	Includes summary section in the timing report (the default value).
no	Excludes summary section in the timing report

-analysis *value*

Specifies whether the report will consider minimum analysis or maximum analysis.

Value	Description
-------	-------------

Value	Description
min	Timing report considers minimum analysis
max	Timing report considers maximum analysis (the default value)

`-use_slack_threshold` *value*

Specifies whether the report will consider slack threshold.

Value	Description
yes	Includes slack threshold in the timing report.
no	Excludes slack threshold in the timing report (the default value)

`-slack_threshold` *value*

Specifies the threshold to consider when reporting path slacks. This is a floating-point number in nanoseconds (ns). By default, there is no threshold (all slacks are reported).

`-print_paths` *value*

Specifies whether the path section (clock domains and in-to-out paths) will be printed in the timing report.

Value	Description
yes	Includes path section in the timing report (the default value)
no	Excludes path sections from the timing report

`-max_paths` *value*

Defines the maximum number of paths to display for each set. This is a positive integer value greater than zero. The default is 5.

`-max_expanded_paths` *value*

Defines the number of paths to expand per set. This is a positive integer value greater than zero. The default is 1.

`-include_user_sets` *value*

Defines whether to include the user defined sets in the timing report.

Value	Description
yes	Includes user defined sets in the timing report (the default value)
no	Excludes user defined sets from the timing report

`-include_pin_to_pin` *value*

Specifies whether to show pin-to-pin paths in the timing report.

Value	Description
-------	-------------



Value	Description
yes	Includes pin-to-pin paths in the timing report (the default value).
no	Excludes pin-to-pin paths from the timing report

`-include_clock_domains` *value*

Defines whether to include clock domains in the timing report.

Value	Description
yes	Includes clock domains
no	Excludes clock domains from the timing report

`-select_clock_domains` *value*

Specifies whether to show the clock domain list in the timing report.

Value	Description
yes	Includes the clock domain list in the timing report
no	Excludes the clock domain list from the timing report (the default value)

`-clock_domain` *clock\_domain\_list*

Defines the clock domain to be considered in the clock domain section. The domain list is a series of strings with domain names separated by spaces. Both the summary and the path sections in the timing report display only the listed clock domains.

`-format` *value*

Specifies the output format of the generated the report.

Value	Description
text	Generates a text report; text is the default value
csv	Generates the report in a comma-separated value format which you can import into a spreadsheet

## Supported Families

IGLOO, ProASIC3, SmartFusion, Fusion, ProASIC<sup>PLUS</sup>, ProASIC, Axcelerator, and SX-A

## Exceptions

None

## Examples

The following example generates a timing report named `timing_report.txt`. The report does not print the summary section. It includes a max-delay analysis and only reports paths with a slack value less than 0.50 ns. It reports a maximum of 3 paths per section and does not report any expanded paths. It only reports timing information for the clock domains `count8_clock` and `count2_clk`.

```
report -type timing -print_summary no \
-analysis max \
-use_slack_threshold yes \
-slack_threshold 0.50 \
-print_paths yes -max_paths 3 \
-max_expanded_paths 0 \
-include_user_sets yes \
-include_pin_to_pin yes \
-select_clock_domains yes \
-clock_domain {count8_clock count2_clk} \
timing_report.txt
```

### See Also

[Tcl documentation conventions](#)

[report \(Timing violations\) using SmartTime](#)

[report \(Datasheet\) using SmartTime](#)

## report (Timing violations) using SmartTime

Creates a timing violations report.

```
report -type timing_violations filename \
[-analysis value]\
[-use_slack_threshold value]\
[-slack_threshold value]\
[-limit_max_paths value]\
[-max_paths value]\
[-max_expanded_paths value] \
[-format value]
```

## Arguments

*filename*

Specifies the name and destination of the timing violations report.

`-type timing_violations`

Specifies the type of report to generate.

`-analysis value`

Specifies whether to consider minimum analysis or maximum analysis in the timing violations report.

Value	Description
min	Timing report considers minimum analysis
max	Timing report considers maximum analysis (the default value)

`-use_slack_threshold` *value*

Specifies whether to consider the slack threshold in the timing violations report.

Value	Description
yes	Includes slack threshold in the timing violations report
no	Excludes slack threshold in the timing violations report (the default value)

`-slack_threshold` *value*

Specifies the threshold to consider when reporting path slacks. This value is a floating-point number in nanoseconds (ns). By default, there is no threshold (all slacks reported).

`-limit_max_paths` *value*

Specifies if the paths are limited by the number of paths.

Value	Description
yes	Limits the maximum number of paths to report
no	Specifies that there is no limit to the number of paths to report (the default value)

`-max_paths` *value*

Specifies the maximum number of paths to display for each set. This value is a positive integer value greater than zero. Default is 100.

`-max_expanded_paths` *value*

Specifies the number of paths to expand per set. This value is a positive integer value greater than zero. The default is 0.

`-format` *value*

Specifies the output format of the generated report.

Value	Description
text	Generates a text report; text is the default value
csv	Generates the report in a comma-separated value format which you can import into a spreadsheet

## Supported Families

IGLOO, ProASIC3, SmartFusion, Fusion, ProASIC<sup>PLUS</sup>, ProASIC, Axcelerator, and SX-A

## Exceptions

None

## Examples

The following example generates a timing violations report named `timg_viol.txt`. The report considers an analysis using maximum delays and does not filter paths based on slack threshold. It reports 2 paths per section and 1 expanded path per section.

```
report -type timing_violations \  
-analysis max -use_slack_threshold no \  
-limit_max_paths -yes \  
-max_paths 2 \  
-max_expanded_paths 1 \  
timg_viol.txt
```

## See Also

[Tcl documentation conventions](#)

[report \(Timing\) using SmartTime](#)

[report \(Datasheet\) using SmartTime](#)

## save\_design

The `save_design` command saves the current design in Designer to a file. If `filename` is not a complete path name, the ADB file is written into the current working directory.

```
save_design filename
```

## Arguments

The design is written to a file denoted by the variable `filename` as an ADB file.

## Supported Families

All

## Exceptions

None

## Example

Example 1: Saves the design to a file “test.adb” in the current folder.

```
save_design {test.adb}
```

Example 2: Save design and check if it saved successfully.

```
set designFile {d:/test/my_design.adb}
if { [catch { save_design $designFile } ] {
    puts "Failed to save design"
    # Handle Failure
} else {
    puts "Design saved successfully"
    # Proceed to make further changes
}
```

### See Also

[close\\_design](#)

[new\\_design](#)

[open\\_design](#)

## set\_clock\_latency

Defines the delay between an external clock source and the definition pin of a clock within SmartTime.

```
set_clock_latency -source [-rise][-fall][-early][-late] delay clock
```

### Arguments

-source

Specifies the source latency on a clock pin, potentially only on certain edges of the clock.

-rise

Specifies the edge for which this constraint will apply. If neither or both rise are passed, the same latency is applied to both edges.

-fall

Specifies the edge for which this constraint will apply. If neither or both rise are passed, the same latency is applied to both edges.

-invert

Specifies that the generated clock waveform is inverted with respect to the reference clock.

-late

Optional. Specifies that the latency is late bound on the latency. The appropriate bound is used to provide the most pessimistic timing scenario. However, if the value of "-late" is less than the value of "-early", optimistic timing takes place which could result in incorrect analysis. If neither or both "-early" and "-late" are provided, the same latency is used for both bounds, which results in the latency having no effect for single clock domain setup and hold checks.

-early

Optional. Specifies that the latency is early bound on the latency. The appropriate bound is used to provide the most pessimistic timing scenario. However, if the value of "-late" is less than the value of "-early", optimistic timing takes place which could result in incorrect analysis. If neither or both "-early" and "-late" are provided, the same latency is used for both bounds, which results in the latency having no effect for single clock domain setup and hold checks.

*delay*

Specifies the latency value for the constraint.

*clock*

Specifies the clock to which the constraint is applied. This clock must be constrained.

## Supported Families

IGLOO, ProASIC3, SmartFusion, Fusion, ProASIC<sup>PLUS</sup>, ProASIC (for analysis), Axcelerator, RTAX-S,eX, and SX-A

## Description

Clock source latency defines the delay between an external clock source and the definition pin of a clock within SmartTime. It behaves much like an input delay constraint. You can specify both an "early" delay and a "late" delay for this latency, providing an uncertainty which SmartTime propagates through its calculations. Rising and falling edges of the same clock can have different latencies. If only one value is provided for the clock source latency, it is taken as the exact latency value, for both rising and falling edges.

## Exceptions

- None

## Examples

The following example sets an early clock source latency of 0.4 on the rising edge of main\_clock. It also sets a clock source latency of 1.2, for both the early and late values of the falling edge of main\_clock. The late value for the clock source latency for the falling edge of main\_clock remains undefined.

```
set_clock_latency -source -rise -early 0.4 { main_clock }
set_clock_latency -source -fall 1.2 { main_clock }
```

### See Also

[create\\_clock](#)

[create\\_generated\\_clock](#)

[Tcl Command Documentation Conventions](#)

## set\_clock\_uncertainty

Specifies a clock-to-clock uncertainty between two clocks (from and to) and returns the ID of the created constraint if the command succeeded.

```
set_clock_uncertainty uncertainty -from | -rise_from | -fall_from from_clock_list -to | -
rise_to | -fall_to to_clock_list -setup {value} -hold {value}
```

## Arguments

*uncertainty*

Specifies the time in nanoseconds that represents the amount of variation between two clock edges.

-from

Specifies that the clock-to-clock uncertainty applies to both rising and falling edges of the source clock list. Only one of the -from, -rise\_from, or -fall\_from arguments can be specified for the constraint to be valid.

-rise\_from

Specifies that the clock-to-clock uncertainty applies only to rising edges of the source clock list. Only one of the -from, -rise\_from, or -fall\_from arguments can be specified for the constraint to be valid.

-fall\_from

Specifies that the clock-to-clock uncertainty applies only to falling edges of the source clock list. Only one of the -from, -rise\_from, or -fall\_from arguments can be specified for the constraint to be valid.

*from\_clock\_list*

Specifies the list of clock names as the uncertainty source.

-to

Specifies that the clock-to-clock uncertainty applies to both rising and falling edges of the destination clock list. Only one of the -to, -rise\_to, or -fall\_to arguments can be specified for the constraint to be valid.

-rise\_to

Specifies that the clock-to-clock uncertainty applies only to rising edges of the destination clock list. Only one of the -to, -rise\_to, or -fall\_to arguments can be specified for the constraint to be valid.

-fall\_to

Specifies that the clock-to-clock uncertainty applies only to falling edges of the destination clock list. Only one of the -to, -rise\_to, or -fall\_to arguments can be specified for the constraint to be valid.

*to\_clock\_list*

Specifies the list of clock names as the uncertainty destination.

-setup

Specifies that the uncertainty applies only to setup checks. If none or both -setup and -hold are present, the uncertainty applies to both setup and hold checks.

-hold

Specifies that the uncertainty applies only to hold checks. If none or both -setup and -hold are present, the uncertainty applies to both setup and hold checks.

## Supported Families

IGLOO, ProASIC3, SmartFusion, Fusion, ProASIC<sup>PLUS</sup>, ProASIC (for analysis), Axcelerator, RTAX-S, eX (for analysis), SX-A (for analysis)

## Description

The set\_clock\_uncertainty command sets the timing uncertainty between two clock waveforms or maximum clock skew. Timing between clocks have no uncertainty unless you specify it.

## Exceptions

- None

## Examples

```
set_clock_uncertainty 10 -from Clk1 -to Clk2
set_clock_uncertainty 0 -from Clk1 -fall_to { Clk2 Clk3 } -setup
set_clock_uncertainty 4.3 -fall_from { Clk1 Clk2 } -rise_to *
```

```
set_clock_uncertainty 0.1 -rise_from [ get_clocks { Clk1 Clk2 } ] -fall_to { Clk3 Clk4 }  
-setup  
set_clock_uncertainty 5 -rise_from Clk1 -to [ get_clocks {*} ]
```

### See Also

[create\\_clock](#)  
[create\\_generated\\_clock](#)  
[remove\\_clock\\_uncertainty](#)

## set\_current\_scenario

Specifies the timing scenario for the Timing Analyzer to use. All commands that follow this command will apply to the specified timing scenario.

```
set_current_scenario name
```

### Arguments

*name*

Specifies the name of the timing scenario to which to apply all commands from this point on.

### Supported Families

IGLOO, ProASIC3, SmartFusion, Fusion, Axcelerator, and RTAX-S

### Description

A timing scenario is a set of timing constraints used with a design. If the specified scenario is already the current one, this command has no effect.

After setting the current scenario, constraints can be listed, added, or removed, the checker can be invoked on the set of constraints, and so on.

This command uses the specified timing scenario to compute timing analysis.

### Exceptions

- None

### Example

```
set_current_scenario scenario_A
```

### See Also

[get\\_current\\_scenario](#)  
[Tcl Command Documentation Conventions](#)



## set\_defvar

The set\_defvar command sets an internal variable in the Designer system. You must specify at least one argument for this command.

```
set_defvar variable value
```

### Arguments

*Variable* must be a valid Designer internal variable and could be accompanied by an optional value. If the *value* is provided, the *variable* is set the value. If the *value* is null the *variable* is reset.

### Supported Families

All

### Exceptions

None.

### Example

Example 1:

```
set_defvar "FORMAT" "VHDL"  
Sets the FORMAT internal variable to VHDL.
```

Example 2:

```
set variableToSet "DESIGN"  
set valueOfVariable "VHDL"  
set_defvar $variableToSet $valueOfVariable
```

These commands set the FORMAT variable to VHDL, shows the use of variables for this command.

### See Also

[get\\_defvar](#)

## set\_design

This set\_design command specifies the design name, family and path in which Designer will process the design. This step is absolutely required before importing the source files.

```
set_design -name design_name -family family_name -pathpath_name
```

**Note:** Note: You need all three arguments for this command to set up your design.

### Arguments

-name *design\_name*

The name of the design. This is used as the base name for most of the files generated from Designer.

-family *family\_name*

The Actel device family for which the design is being targeted.

-path *path\_name*

The physical path of the directory in which the design files will be created.

## Supported Families

All

## Example

Example 1: Sets up the design and checks if there are any errors

```
set_design -name "test" -family "Accelerator" -path {.  
set desName "test"  
set famName "ACT3"  
set path {d:/examples/test}  
  
if { [catch { set_design -name $desName -family $famName -path $path } ] {  
    puts "Failed setup design"  
    # Handle Failure  
} else {  
    puts "Design setup successful"  
    # Proceed to Import source files  
}
```

### See Also

[new\\_design](#)

[set\\_device](#)

## set\_device

The `set_device` command specifies the type of device and its parameters. You must specify at least one option for this command. Some of the options may not apply for certain families that do not support the features.

```
set_device -family family_name -die die_name -package package_name -speed speed_grade -voltage  
voltage -voltrange volt_range -temprange temp_range -iostd default_io_std -pci value -jtag value  
-probe value -trst value -radexp value -vcci_1.2_voltrange value -vcci_1.2_widerange value -  
vcci_1.5_voltrange value -vcci_1.8_voltrange value -vcci_2.5_voltrange value -  
vcci_3.3_voltrange value -vcci_3.3_widerange value
```

## Arguments

-family *family\_name*

Specifies the name of the FPGA device family.

-die *die\_name*

Specifies the part name.

-package *package\_name*

Specifies the selected package for the device.

-speed *speed\_grade*

Specifies the speed grade of the part.

-voltage *voltage*

Specifies the core voltage of the device. You can also use it to define the I/O voltage of the part. For example, if you are using a RTSX with a 3.3 to 2.5 voltage, you can use

-voltage 3.3/2.5

-voltrange *volt\_range*

Specifies the voltage range to be applied for the device. It is generally MIL, COM and IND denoting Military, Commercial and Industrial respectively.

Alternatively, you can also specify custom values for Best, Typical, and Worst: -voltrange "1.60 1.50 1.40"

-temprange *temp\_range*

Specifies the temperature range to be applied for the device. Temperature ranges are MIL, COM and IND denoting Military, Commercial and Industrial respectively. Automotive applications generally use the Automotive, TGrade1, or TGrade2 temperature range.

-iostd *default\_io\_std*

Specifies the default I/O standard of the part.

-pci *value*

Used if the device needs to configure the I/Os for PCI specification. This parameter is equivalent to setting your I/O attributes to PCI in the Device Selection Wizard. Values are summarized in the table below.

Value	Description
yes	Device is configured for PCI specification
no	Device is not configured for PCI specification

-jtag *value*

Specifies if pins need to be reserved for JTAG. Values are summarized in the table below.

Value	Description
yes	Pins are reserved for JTAG
no	Pins are not reserved for JTAG

-probe *value*

Specifies if the pins need to be preserved for probing. Values are summarized in the table below.

Value	Description
yes	Pins are preserved for probing

Value	Description
no	Pins not preserved for probing

`-trst value`

Specifies if the pins need to be reserved for JTAG test reset. Values are summarized in the table below.

Value	Description
yes	Pins are preserved for JTAG test reset
no	Pins are not preserved for JTAG test reset

`-radexp value`

Specifies the radiation value (in Krad) for radiation tolerant devices.

`-vcci_1.2_voltrange value -vcci_1.5_voltrange value -vcci_1.8_voltrange value -vcci_2.5_voltrange value -vcci_3.3_voltrange value`

Specifies the voltage range for VCCIx.x. Values are summarized in the table below.

Value	Description
MIL	Sets the voltage range for VCCIx.x to Military
COM	Sets the voltage range for VCCIx.x to Commercial
IND	Sets the voltage range for VCCIx.x to Industrial

Alternatively, you can also specify custom values for Best, Typical, and Worst: `-vcci_x.x_voltrange "1.26 1.20 1.14"`

**Note:** Note: This argument is available only for IGLOO, ProASIC3, SmartFusion and Fusion families of devices.

`-vcci_1.2_widerange value`

Specifies the voltage range for VCCI1.2 as wide range. Values are summarized in the table below.

Value	Description
yes	Specifies the voltage range for VCCI1.2 as wide range and sets the def variable IS_VCCI_1.2_WR as "1"
no	Does not specify the voltage range for VCCI1.2 as wide range

**Note:** Note: This argument is available only for IGLOO, ProASIC3, SmartFusion and Fusion families of devices.

`-vcci_3.3_widerange value`

Specifies the voltage range for VCCI3.3 as wide range. Values are summarized in the table below.

Value	Description
yes	Specifies the voltage range for VCCI3.3 as wide range and sets the def variable IS_VCCI_3.3_WR as "1"
no	Does not specify the voltage range for VCCI3.3 as wide range

**Note:** Note: This argument is available only for IGLOO, ProASIC3, SmartFusion and Fusion families of devices.

## Supported Families

All

## Example

Example 1: Setting up adesign.

```
set_device -die "APA075" -package "208 PQFP" -speed "STD" -voltage "2.5" \
-jtag "yes" -trst "yes" -temprange "COM" -voltrange "COM" \
-vcci_1.2_voltrange "COM" -vcci_1.2_widerange "no" -vcci_1.5_voltrange "1.60 1.50 1.40"
```

## See Also

[new\\_design](#)

[set\\_design](#)

## set\_disable\_timing

Disables timing arcs within a cell and returns the ID of the created constraint if the command succeeded.

```
set_disable_timing -from value -to value name
```

## Arguments

-from *from\_port*

Specifies the starting port. The -from and -to arguments must either both be present or both omitted for the constraint to be valid.

-to *to\_port*

Specifies the ending port. The -from and -to arguments must either both be present or both omitted for the constraint to be valid.

*name*

Specifies the cell name where the timing arcs will be disabled.

## Supported Families

IGLOO, ProASIC3, SmartFusion, Fusion, Axcelerator, and RTAX-S

## Exceptions

- None

## Example

```
set_disable_timing -from A -to Y a2
```

## set\_false\_path

Identifies paths that are considered false and excluded from the timing analysis in the current timing scenario.

```
set_false_path [-from from_list] [-through through_list] [-to to_list]
```

## Arguments

-from *from\_list*

Specifies a list of timing path starting points. A valid timing starting point is a clock, a primary input, an inout port, or a clock pin of a sequential cell.

-through *through\_list*

Specifies a list of pins, ports, cells, or nets through which the disabled paths must pass.

-to *to\_list*

Specifies a list of timing path ending points. A valid timing ending point is a clock, a primary output, an inout port, or a data pin of a sequential cell.

## Supported Families

IGLOO, ProASIC3, SmartFusion, Fusion, ProASIC<sup>PLUS</sup>, ProASIC (for analysis), Axcelerator, RTAX-S, eX (-through option), and SX-A (-through option)

## Description

The `set_false_path` command identifies specific timing paths as being false. The false timing paths are paths that do not propagate logic level changes. This constraint removes timing requirements on these false paths so that they are not considered during the timing analysis. The path starting points are the input ports or register clock pins, and the path ending points are the register data pins or output ports. This constraint disables setup and hold checking for the specified paths.

The false path information always takes precedence over multiple cycle path information and overrides maximum delay constraints. If more than one object is specified within one `-through` option, the path can pass through any objects.

You must specify at least one of the `-from`, `-to`, or `-through` arguments for this constraint to be valid.

## Examples

The following example specifies all paths from clock pins of the registers in clock domain `clk1` to data pins of a specific register in clock domain `clk2` as false paths:

```
set_false_path -from [get_clocks {clk1}] -to reg_2:D
```

The following example specifies all paths through the pin U0/U1:Y to be false:

```
set_false_path -through U0/U1:Y
```

### See Also

[Tcl Command Documentation Conventions](#)

## set\_input\_delay

Creates an input delay on a port list by defining the arrival time of an input relative to a clock in the current scenario.

```
set_input_delay delay_value -clock clock_ref [-max] [-min] [-clock_fall] input_list
```

### Arguments

*delay\_value*

Specifies the arrival time in nanoseconds that represents the amount of time for which the signal is available at the specified input after a clock edge.

-clock *clock\_ref*

Specifies the clock reference to which the specified input delay is related. This is a mandatory argument. If you do not specify -max or -min options, the tool assumes the maximum and minimum input delays to be equal.

-max

Specifies that *delay\_value* refers to the longest path arriving at the specified input. If you do not specify -max or -min options, the tool assumes maximum and minimum input delays to be equal.

-min

Specifies that *delay\_value* refers to the shortest path arriving at the specified input. If you do not specify -max or -min options, the tool assumes maximum and minimum input delays to be equal.

-clock\_fall

Specifies that the delay is relative to the falling edge of the clock reference. The default is the rising edge.

*input\_list*

Provides a list of input ports in the current design to which *delay\_value* is assigned. If you need to specify more than one object, enclose the objects in braces ({}).

### Supported Families

IGLOO, ProASIC3, SmartFusion, Fusion, ProASIC<sup>PLUS</sup>, ProASIC (for analysis), Axcelerator, RTAX-S, eX (for analysis), SX-A (for analysis)

### Description

The `set_input_delay` command sets input path delays on input ports relative to a clock edge. This usually represents a combinational path delay from the clock pin of a register external to the current design. For in/out (bidirectional) ports, you can specify the path delays for both input and output modes. The tool adds input delay to path delay for paths starting at primary inputs.

A clock is a singleton that represents the name of a defined clock constraint. This can be:

- a single port name used as source for a clock constraint

- a single pin name used as source for a clock constraint; for instance reg1:CLK. This name can be hierarchical (for instance toplevel/block1/reg2:CLK)
- an object accessor that will refer to one clock: [get\_clocks {clk}]

## Examples

The following example sets an input delay of 1.2ns for port data1 relative to the rising edge of CLK1:

```
set_input_delay 1.2 -clock [get_clocks CLK1] [get_ports data1]
```

The following example sets a different maximum and minimum input delay for port IN1 relative to the falling edge of CLK2:

```
set_input_delay 1.0 -clock_fall -clock CLK2 -min {IN1}
set_input_delay 1.4 -clock_fall -clock CLK2 -max {IN1}
```

### See Also

[set\\_output\\_delay](#)

[Tcl Command Documentation Conventions](#)

## set\_max\_delay

Specifies the maximum delay for the timing paths in the current scenario.

```
set_max_delay delay_value [-from from_list] [-to to_list] [-through through_list]
```

### Arguments

*delay\_value*

Specifies a floating point number in nanoseconds that represents the required maximum delay value for specified paths.

- If the path starting point is on a sequential device, the tool includes clock skew in the computed delay.
- If the path starting point has an input delay specified, the tool adds that delay value to the path delay.
- If the path ending point is on a sequential device, the tool includes clock skew and library setup time in the computed delay.
- If the ending point has an output delay specified, the tool adds that delay to the path delay.

-from *from\_list*

Specifies a list of timing path starting points. A valid timing starting point is a clock, a primary input, an inout port, or a clock pin of a sequential cell.

-to *to\_list*

Specifies a list of timing path ending points. A valid timing ending point is a clock, a primary output, an inout port, or a data pin of a sequential cell.

-through *through\_list*



Specifies a list of pins, ports, cells, or nets through which the timing paths must pass.

## Supported Families

IGLOO, ProASIC3, SmartFusion, Fusion, ProASIC<sup>PLUS</sup>, ProASIC (for analysis), Axcelerator, RTAX-S, eX (-through option), and SX-A (-through option)

## Description

This command specifies the required maximum delay for timing paths in the current design. The path length for any startpoint in `from_list` to any endpoint in `to_list` must be less than `delay_value`.

The timing engine automatically derives the individual maximum delay targets from clock waveforms and port input or output delays.

The maximum delay constraint is a timing exception. This constraint overrides the default single cycle timing relationship for one or more timing paths. This constraint also overrides a multicycle path constraint.

You must specify at least one of the `-from`, `-to`, or `-through` arguments for this constraint to be valid.

## Examples

The following example sets a maximum delay by constraining all paths from `ff1a:CLK` or `ff1b:CLK` to `ff2e:D` with a delay less than 5 ns:

```
set_max_delay 5 -from {ff1a:CLK ff1b:CLK} -to {ff2e:D}
```

The following example sets a maximum delay by constraining all paths to output ports whose names start by "out" with a delay less than 3.8 ns:

```
set_max_delay 3.8 -to [get_ports out*]
```

### See Also

[set\\_min\\_delay](#)

[remove\\_max\\_delay](#)

[Tcl Command Documentation Conventions](#)

## set\_min\_delay

Specifies the minimum delay for the timing paths in the current scenario.

```
set_min_delay delay_value [-from from_list] [-to to_list] [-through through_list]
```

## Arguments

*delay\_value*

Specifies a floating point number in nanoseconds that represents the required minimum delay value for specified paths.

- If the path starting point is on a sequential device, the tool includes clock skew in the computed delay.

- If the path starting point has an input delay specified, the tool adds that delay value to the path delay.
- If the path ending point is on a sequential device, the tool includes clock skew and library setup time in the computed delay.
- If the ending point has an output delay specified, the tool adds that delay to the path delay.

-from *from\_list*

Specifies a list of timing path starting points. A valid timing starting point is a clock, a primary input, an inout port, or a clock pin of a sequential cell.

-to *to\_list*

Specifies a list of timing path ending points. A valid timing ending point is a clock, a primary output, an inout port, or a data pin of a sequential cell.

-through *through\_list*

Specifies a list of pins, ports, cells, or nets through which the timing paths must pass.

## Supported Families

IGLOO, ProASIC3, SmartFusion, Fusion, ProASIC<sup>PLUS</sup>, ProASIC (for analysis), Axcelerator, RTAX-S, eX (-through option), and SX-A (-through option)

## Description

This command specifies the required minimum delay for timing paths in the current design. The path length for any startpoint in *from\_list* to any endpoint in *to\_list* must be less than *delay\_value*.

The timing engine automatically derives the individual minimum delay targets from clock waveforms and port input or output delays.

The minimum delay constraint is a timing exception. This constraint overrides the default single cycle timing relationship for one or more timing paths. This constraint also overrides a multicycle path constraint.

You must specify at least one of the *-from*, *-to*, or *-through* arguments for this constraint to be valid.

## Examples

The following example sets a minimum delay by constraining all paths from *ff1a:CLK* or *ff1b:CLK* to *ff2e:D* with a delay less than 5 ns:

```
set_min_delay 5 -from {ff1a:CLK ff1b:CLK} -to {ff2e:D}
```

The following example sets a minimum delay by constraining all paths to output ports whose names start by "out" with a delay less than 3.8 ns:

```
set_min_delay 3.8 -to [get_ports out*]
```

## See Also

[set\\_max\\_delay](#)

[remove\\_min\\_delay](#)

[Tcl Command Documentation Conventions](#)

## set\_multicycle\_path

Defines a path that takes multiple clock cycles in the current scenario.

```
set_multicycle_path ncycles [-setup] [-hold] [-from from_list[-through through_list[-to to_list
```

### Arguments

#### *ncycles*

Specifies an integer value that represents a number of cycles the data path must have for setup or hold check. The value is relative to the starting point or ending point clock, before data is required at the ending point.

#### -setup

Optional. Applies the cycle value for the setup check only. This option does not affect the hold check. The default hold check will be applied unless you have specified another set\_multicycle\_path command for the hold value.

#### -hold

Optional. Applies the cycle value for the hold check only. This option does not affect the setup check.

**Note:** Note: If you do not specify "-setup" or "-hold", the cycle value is applied to the setup check and the default hold check is performed (*ncycles* -1).

#### -from *from\_list*

Specifies a list of timing path starting points. A valid timing starting point is a clock, a primary input, an inout port, or a clock pin of a sequential cell.

#### -through *through\_list*

Specifies a list of pins or ports through which the multiple cycle paths must pass.

#### -to *to\_list*

Specifies a list of timing path ending points. A valid timing ending point is a clock, a primary output, an inout port, or a data pin of a sequential cell.

### Supported Families

IGLOO, ProASIC3, SmartFusion, Fusion, ProASIC<sup>PLUS</sup>, ProASIC (for analysis), Axcelerator, RTAX-S, eX (for analysis), SX-A (for analysis)

### Description

Setting multiple cycle paths constraint overrides the single cycle timing relationships between sequential elements by specifying the number of cycles that the data path must have for setup or hold checks. If you change the multiplier, it affects both the setup and hold checks.

False path information always takes precedence over multiple cycle path information. A specific maximum delay constraint overrides a general multiple cycle path constraint.

If you specify more than one object within one -through option, the path passes through any of the objects.

You must specify at least one of the -from, -to, or -through arguments for this constraint to be valid.

## Exceptions

- Multiple priority management is not supported in Actel designs. All multiple cycle path constraints are handled with the same priority.

## Examples

The following example sets all paths between reg1 and reg2 to 3 cycles for setup check. Hold check is measured at the previous edge of the clock at reg2.

```
set_multicycle_path 3 -from [get_pins {reg1}] -to [get_pins {reg2}]
```

The following example specifies that four cycles are needed for setup check on all paths starting at the registers in the clock domain ck1. Hold check is further specified with two cycles instead of the three cycles that would have been applied otherwise.

```
set_multicycle_path 4 -setup -from [get_clocks {ck1}]
set_multicycle_path 2 -hold -from [get_clocks {ck1}]
```

### See Also

[remove\\_multicycle\\_path](#)

[Tcl Command Documentation Conventions](#)

## set\_output\_delay

Defines the output delay of an output relative to a clock in the current scenario.

```
set_output_delay delay_value -clock clock_ref [-max] [-min] [-clock_fall] output_list
```

## Arguments

*delay\_value*

Specifies the amount of time before a clock edge for which the signal is required. This represents a combinational path delay to a register outside the current design plus the library setup time (for maximum output delay) or hold time (for minimum output delay).

-clock *clock\_ref*

Specifies the clock reference to which the specified output delay is related. This is a mandatory argument. If you do not specify -max or -min options, the tool assumes the maximum and minimum input delays to be equal.

-max

Specifies that *delay\_value* refers to the longest path from the specified output. If you do not specify -max or -min options, the tool assumes the maximum and minimum output delays to be equal.

-min

Specifies that *delay\_value* refers to the shortest path from the specified output. If you do not specify -max or -min options, the tool assumes the maximum and minimum output delays to be equal.

-clock\_fall

Specifies that the delay is relative to the falling edge of the clock reference. The default is the rising edge.

*output\_list*

Provides a list of output ports in the current design to which *delay\_value* is assigned. If you need to specify more than one object, enclose the objects in braces ({}).

## Supported Families

IGLOO, ProASIC3, SmartFusion, Fusion, ProASIC<sup>PLUS</sup>, ProASIC (for analysis), Axcelerator, RTAX-S, eX (for analysis), SX-A (for analysis)

## Description

The `set_output_delay` command sets output path delays on output ports relative to a clock edge. Output ports have no output delay unless you specify it. For in/out (bidirectional) ports, you can specify the path delays for both input and output modes. The tool adds output delay to path delay for paths ending at primary outputs.

## Examples

The following example sets an output delay of 1.2ns for port OUT1 relative to the rising edge of CLK1:

```
set_output_delay 1.2 -clock [get_clocks CLK1] [get_ports OUT1]
```

The following example sets a different maximum and minimum output delay for port OUT1 relative to the falling edge of CLK2:

```
set_output_delay 1.0 -clock_fall -clock CLK2 -min {OUT1}
```

```
set_output_delay 1.4 -clock_fall -clock CLK2 -max {OUT1}
```

### See Also

[remove\\_output\\_delay](#)

[set\\_input\\_delay](#)

[Tcl Command Documentation Conventions](#)

# smartpower\_add\_new\_custom\_mode

Creates a new custom mode.

```
smartpower_add_new_custom_mode -name {mode_name} -base_mode {base_mode} -description {mode_description}
```

## Arguments

`-name` {mode\_name}

Specifies the name of the new custom mode.

`-base_mode` {base\_mode}

Specifies the name of the base mode used to create the new custom mode.

`-description` {mode\_description}

Specifies the description of the new custom mode.

## Supported Families

IGLOO, ProASIC3, SmartFusion, Fusion, ProASIC<sup>PLUS</sup>, ProASIC, and Axcelerator

## Notes

- None

## Exceptions

- None

## Examples

This example creates a new custom mode "Cust\_1" based on the Active mode:

```
smartpower_add_new_custom_mode -name {Cust_1} -base_mode {Active} -description
{frequency 10 MHz}
```

### See Also

[smartpower\\_remove\\_custom\\_mode](#)

# smartpower\_add\_new\_scenario

Creates a new scenario.

```
smartpower_add_new_scenario -name {value} -description {value} -mode {value}
```

## Arguments

-name {value}

Specifies the name of the new scenario.

-description {value}

Specifies the description of the new scenario.

-mode {<operating mode>:<duration>}+

Specifies the mode(s) and duration(s) for the specified scenario.

## Supported Families

IGLOO, ProASIC3, SmartFusion, Fusion, ProASIC<sup>PLUS</sup>, ProASIC, and Axcelerator

## Notes

- None

## Exceptions

- None

## Examples

This example creates a new scenario called myscenario:

```
smartpower_add_new_scenario -name myscenario -description mynewscenario -mode active:30
+ shutdown:30 + active:40
```

# smartpower\_add\_pin\_in\_domain

Adds a pin into a clock or set domain.

```
smartpower_add_pin_in_domain -pin_name {pin_name} -pin_type {value} -domain_name
{domain_name} -domain_type {value}
```

## Arguments

`-pin_name {pin_name}`

Specifies the name of the pin to add to the domain.

`-pin_type {value}`

Specifies the type of the pin to add. The following table shows the acceptable values for this argument:

Value	Description
clock	The pin to add is a clock pin
data	The pin to add is a data pin

`-domain_name {domain_name}`

Specifies the name of the domain in which to add the specified pin.

`-domain_type {value}`

Specifies the type of domain in which to add the specified pin. The following table shows the acceptable values for this argument:

Value	Description
clock	The domain is a clock domain
set	The domain is a set domain

## Supported Families

IGLOO, ProASIC3, SmartFusion, Fusion, ProASIC<sup>PLUS</sup>, ProASIC, and Axcelerator

## Notes

- The `domain_name` must be a name of an existing domain.
- The `pin_name` must be a name of a pin that exists in the design.

## Exceptions

- None

## Examples

The following example adds a clock pin to an existing Clock domain:

```
smartpower_add_pin_in_domain -pin_name { XCMP3/U0/U1:Y } -pin_type {clock} -domain_name
{clk1} -domain_type {clock}
```

The following example adds a data pin to an existing Set domain:

```
smartpower_add_pin_in_domain -pin_name {XCMP3/U0/U1:Y} -pin_type {data} -domain_name
{myset} -domain_type {set}
```

### See Also

[smartpower\\_remove\\_pin\\_of\\_domain](#)

## smartpower\_change\_clock\_statistics

Changes the default frequencies and probabilities for a specific domain.

```
smartpower_change_clock_statistics -domain_name {value} -clocks_freq {value} -
clocks_proba {value} -registers_freq {value} -registers_proba {value} -set_reset_freq
{value} -set_reset_proba {value} -primaryinputs_freq {value} -primaryinputs_proba {value} -
combinational_freq {value} -combinational_proba {value}
```

### Arguments

`-domain_name {value}`

Specifies the domain name in which to initialize frequencies and probabilities.

`-clocks_freq {value}`

Specifies the user input frequency in Hz, KHz, or MHz for all clocks.

`-clocks_proba {value}`

Specifies the user input probability in % for all clocks.

`-registers_freq {value}`

Specifies the user input frequency (in Hz, KHz, or MHz) or the toggle rate (in %). If the unit is not provided and toggle rate is active, the value is handled as a toggle rate; if toggle rate is not active, the value is handled as a frequency.

`-registers_proba {value}`

Specifies the user input probability in % for all registers.

`-set_reset_freq {value}`

Specifies the user input frequency (in Hz, KHz, or MHz) or the toggle rate (in %). If the unit is not provided and toggle rate is active, the value is handled as a toggle rate; if toggle rate is not active, the value is handled as a frequency.

`-set_reset_proba {value}`

Specifies the user input probability in % for all set/reset nets.

`-primaryinputs_freq {value}`

Specifies the user input frequency (in Hz, KHz, or MHz) or the toggle rate (in %). If the unit is not provided and toggle rate is active, the value is handled as a toggle rate; if toggle rate is not active, the value is handled as a frequency.

`-primaryinputs_proba {value}`

Specifies the user input probability in % for all primary inputs.

`-combinational_freq {value}`

Specifies the user input frequency (in Hz, KHz, or MHz) or the toggle rate (in %). If the unit is not provided and toggle rate is active, the value is handled as a toggle rate; if toggle rate is not active, the value is handled as a frequency.

`-combinational_proba {value}`

Specifies the user input probability in % for all combinational combinational output.



## Supported Families

IGLOO, ProASIC3, SmartFusion, Fusion, ProASIC<sup>PLUS</sup>, ProASIC, and Axcelerator

## Notes

- This command is associated with the functionality of [Initialize frequencies and probabilities](#) dialog box.

## Exceptions

- None

## Examples

The following example initializes all clocks with:

```
smartpower_change_clock_statistics -domain_name {my_domain} -clocks_freq {10 MHz} -
clocks_proba {20} -registers_freq {10 MHz} -registers_proba {20} -set_reset_freq {10
MHz} -set_reset_proba {20} -primaryinputs_freq {10 MHz} -primaryinputs_proba {20} -
combinational_freq {10 MHz} -combinational_proba {20}
```

## smartpower\_change\_setofpin\_statistics

Changes the default frequencies and probabilities for a specific set.

```
smartpower_change_setofpin_statistics -domain_name {value} -data_freq {value} -
data_proba {value}
```

## Arguments

-domain\_name {value}

Specifies the domain name in which to initialize data frequencies and probabilities.

-data\_freq {value}

Specifies the user input data frequency in Hz, KHz, or MHz for all sets of pins.

-data\_proba {value}

Specifies the user input data probability in % for all sets of pins.

## Supported Families

IGLOO, ProASIC3, SmartFusion, Fusion, ProASIC<sup>PLUS</sup>, ProASIC, and Axcelerator

## Notes

- This command is associated with the functionality of [Initialize frequencies and probabilities](#) dialog box.

## Exceptions

- None

## Examples

The following example initializes all clocks with:

```
smartpower_change_setofpin_statistics -domain_name {my_domain} -data_freq {10 MHz} -
data_proba {20}
```

## smartpower\_commit

Saves the changes to the design (.adb) file.

```
smartpower_commit
```

## Arguments

- None

## Supported Families

IGLOO, ProASIC3, SmartFusion, Fusion, ProASIC<sup>PLUS</sup>, ProASIC, and Axcelerator

## Notes

- None

## Exceptions

- None

## Examples

```
smartpower_commit
```

### See Also

[smartpower\\_restore](#)

## smartpower\_create\_domain

Creates a new clock or set domain.

```
smartpower_create_domain -domain_type {value} -domain_name {domain_name}
```

## Arguments

-domain\_type {value}

Specifies the type of domain to create. The following table shows the acceptable values for this argument:

Value	Description
clock	The domain is a clock domain

Value	Description
set	The domain is a set domain

`-domain_name {domain_name}`  
Specifies the name of the new domain.

## Supported Families

IGLOO, ProASIC3, SmartFusion, Fusion, ProASIC<sup>PLUS</sup>, ProASIC, and Axcelerator

## Notes

- The `domain_name` cannot be the name of an existing domain.
- The `domain_type` must be either `clock` or `set`.

## Exceptions

- None

## Examples

The following example creates a new clock domain named "clk2":

```
smartpower_create_domain -domain_type {clock} -domain_name {clk2}
```

The following example creates a new set domain named "myset":

```
smartpower_create_domain -domain_type {set} -domain_name {myset}
```

### See Also

[smartpower\\_remove\\_domain](#)

## smartpower\_edit\_custom\_mode

Edits a custom mode.

```
smartpower_edit_custom_mode -name {old_mode_name} new_name {new_mode_name} -description {mode_description}
```

## Arguments

`-name {old_mode_name}`  
Specifies the name of the custom mode you want to edit.

`-new_name {new_mode_name}`  
Specifies the new name of the custom mode.

`-description {mode_description}`  
Specifies the description of the new custom mode.

## Supported Families

IGLOO, ProASIC3, SmartFusion, Fusion, ProASIC<sup>PLUS</sup>, ProASIC, and Axcelerator

## Notes

- None

## Exceptions

- None

## Examples

This example edits custom mode "Cust\_1" and renames it "Cust\_2":

```
smartpower_edit_custom_mode -name {Cust_1} -new_name {Cust_2} -description {frequency 10 MHz}
```

### See Also

[smartpower\\_remove\\_custom\\_mode](#)

[smartpower\\_add\\_custom\\_mode](#)

## smartpower\_edit\_scenario

Edits a scenario.

```
smartpower_edit_scenario -name {value} -description {value} -mode {value} -new_name {value}
```

## Arguments

-name {value}

Specifies the name of the scenario.

-description {value}

Specifies the description of the scenario.

-mode {<operating mode>:<duration>}

Specifies the mode(s) and duration(s) for the specified scenario.

-new\_name {value}

Specifies the new name for the scenario

## Supported Families

IGLOO, ProASIC3, SmartFusion, Fusion, ProASIC<sup>PLUS</sup>, ProASIC, and Axcelerator

## Notes

- None

## Exceptions

- None

## Examples

This example edits the name of myscenario to finalscenario:

```
smartpower_edit_scenario -name myscenario -new_name finalscenario
```

## smartpower\_init\_do

Initializes the frequencies and probabilities for clocks, registers, set/reset nets, primary inputs, combinational outputs, enables and other sets of pins, and selects a mode for initialization.

```
smartpower_init_do -with {value} -opmode {value} -clocks {value} -registers {value} -
set_reset {value} -primaryinputs {value} -combinational {value} -enables {value} -othersets
{value}
```

## Arguments

-with{value}

This sets the option of initializing frequencies and probabilities with vectorless analysis or with fixed values. The following table shows the acceptable values for this argument:

Value	Description
vectorless	Initializes frequencies and probabilities with vectorless analysis
fixed	Initializes frequencies and probabilities with fixed values

-opmode {value}

Specifies the mode in which to initialize frequencies and probabilities. The mode needs to be based on an Active mode.

-clocks {value}

This sets the option of initializing frequencies and probabilities for all clocks. The following table shows the acceptable values for this argument:

Value	Description
true	Initializes frequencies and probabilities for all clocks
false	Does not initialize frequencies and probabilities for all clocks

-registers {value}

This sets the option of initializing frequencies and probabilities for all registers. The following table shows the acceptable values for this argument:

Value	Description
true	Initializes frequencies and probabilities for all registers
false	Does not initialize frequencies and probabilities for all registers

`-set_reset {value}`

This sets the option of initializing frequencies and probabilities for all set/reset nets. The following table shows the acceptable values for this argument:

Value	Description
true	Initializes frequencies and probabilities for all set/reset nets
false	Does not initialize frequencies and probabilities for all set/reset nets

`-primaryinputs {value}`

This sets the option of initializing frequencies and probabilities for all primary inputs. The following table shows the acceptable values for this argument:

Value	Description
true	Initializes frequencies and probabilities for all primary inputs
false	Does not initialize frequencies and probabilities for all primary inputs

`-combinational {value}`

This sets the option of initializing frequencies and probabilities for all combinational outputs. The following table shows the acceptable values for this argument:

Value	Description
true	Initializes frequencies and probabilities for all combinational outputs
false	Does not initialize frequencies and probabilities for all combinational outputs

`-enables {value}`

This sets the option of initializing frequencies and probabilities for all enable sets of pins. The following table shows the acceptable values for this argument:

Value	Description
true	Initializes frequencies and probabilities for all enable sets of pins
false	Does not initialize frequencies and probabilities for all enable sets of pins

`-othersets {value}`

This sets the option of initializing frequencies and probabilities for all other sets of pins. The following table shows the acceptable values for this argument:

Value	Description
true	Initializes frequencies and probabilities for all other sets of pins
false	Does not initialize frequencies and probabilities for all other sets of pins

## Supported Families

IGLOO, ProASIC3, SmartFusion, Fusion, ProASIC<sup>PLUS</sup>, ProASIC, and Axcelerator

Note: Vectorless estimation is not supported for ProASIC, Proasic<sup>PLUS</sup>, and Axcelerator devices.

## Notes

- This command is associated with the functionality of [Initialize frequencies and probabilities](#) dialog box.

## Exceptions

- None

## Examples

The following example initializes all clocks with:

```
smartpower_init_do -with {vectorless} -opmode {my_mode} -clocks {true} -registers {true}
-asynchronous {true} -primaryinputs {true} -combinational {true} -enables {true} -
othersets {true}
```

## smartpower\_init\_set\_clocks\_options

Initializes the clock frequency options of all clock domains.

```
smartpower_init_set_clocks_options -with_clock_constraints {value} -
with_default_values {value} -freq {value} -duty_cycle {value}
```

## Arguments

`-with_clock_constraints {value}`

This sets the option of initializing the clock frequencies with frequency constraints from SmartTime. The following table shows the acceptable values for this argument:

Value	Description
true	Sets initialize clock frequencies with clock constraints ON
false	Sets initialize clock frequencies with clock constraints OFF

`-with_default_values {value}`

This sets the option of initializing the clock frequencies with a user input default value. The following table shows the acceptable values for this argument:

Value	Description
true	Sets initialize clock frequencies with default values ON
false	Sets initialize clock frequencies with default values OFF

-freq {*value*}  
Specifies the user input frequency in Hz, KHz, or MHz.

-duty\_cycle {*value*}  
Specifies the user input duty cycles in %.

## Supported Families

IGLOO, ProASIC3, SmartFusion, Fusion, ProASIC<sup>PLUS</sup>, ProASIC, and Axcelerator

## Notes

- This command is associated with the functionality of [Initialize frequencies and probabilities](#) dialog box.

## Exceptions

- None

## Examples

The following example initializes all clocks after executing [smartpower\\_init\\_do](#) with `-clocks {true}`:

```
smartpower_init_set_clocks_options -with_clock_constraints {true} -with_default_values {true} -freq {10 MHz} -duty_cycle {20}
```

## smartpower\_init\_set\_combinational\_options

Initializes the frequency and probability of all combinational outputs.

```
smartpower_init_set_combinational_options -freq {value} -proba {value}
```

## Arguments

-freq {*value*}  
Specifies the user input frequency (in Hz, KHz, or MHz) or the toggle rate (in %). If the unit is not provided and toggle rate is active, the value is handled as a toggle rate; if toggle rate is not active, the value is handled as a frequency.

-proba {*value*}  
Specifies the user input probability in %.



## Supported Families

IGLOO, ProASIC3, SmartFusion, Fusion, ProASIC<sup>PLUS</sup>, ProASIC, and Axcelerator

## Notes

- This command is associated with the functionality of [Initialize frequencies and probabilities](#) dialog box.

## Exceptions

- None

## Examples

The following example initializes all combinational signals after executing [smartpower\\_init\\_do](#) with `-combinational {true}`:

```
smartpower_init_set_combinational_options -freq {10 MHz} -proba {20}
```

## smartpower\_init\_setofpins\_values

Initializes the frequency and probability of all sets of pins.

```
smartpower_init_setofpins_values -domain_name {name} -freq {value} -proba {value}
```

## Arguments

`-domain_name {name}`

Specifies the set of pins that will be initialized. The following table shows the acceptable values for this argument:

Value	Description
IOsEnableSet	Specifies that the IOsEnableSet set of pins will be initialized
MemoriesEnableSet	Specifies that the MemoriesEnableSet set of pins will be initialized

`-freq {value}`

Specifies the user input frequency in Hz, MHz, or KHz.

`-proba {value}`

Specifies the user input probability in %.

## Supported Families

IGLOO, ProASIC3, SmartFusion, Fusion, ProASIC<sup>PLUS</sup>, ProASIC, and Axcelerator

## Notes

- This command is associated with the functionality of [Initialize frequencies and probabilities](#) dialog box.

## Exceptions

- None

## Examples

The following example initializes all primary inputs after executing [smartpower\\_init\\_do](#) with `-othersets {true}`:

```
smartpower_init_setofpins_values -domain_name {IOsEnableSet} -freq {10 MHz} -proba {20}
```

## smartpower\_init\_set\_enables\_options

Initializes the clock frequency of all enable clocks with the initialization options.

```
smartpower_init_set_enables_options -freq {value} -proba {value}
```

## Arguments

- freq {value}  
Specifies the user input frequency (in Hz, KHz, or MHz).
- proba {value}  
Specifies the user input probability in %.

## Supported Families

IGLOO, ProASIC3, SmartFusion, Fusion, ProASIC<sup>PLUS</sup>, ProASIC, and Axcelerator

## Notes

- This command is associated with the functionality of [Initialize frequencies and probabilities](#) dialog box.

## Exceptions

- None

## Examples

The following example initializes all clocks after executing [smartpower\\_init\\_do](#) with `-enables {true}`:

```
smartpower_init_set_enables_options -freq {10 MHz} -proba {20}
```

## smartpower\_init\_set\_othersets\_options

Initializes the frequency and probability of all other sets.

```
smartpower_init_set_othersets_options [-freq "decimal value" [ unit { Hz | KHz | MHz } ]"  
[-proba "decimal value"]  
[-with "vectorless / default"]  
[-input_freq "decimal value" [ unit { Hz | KHz | MHz } ]"  
[-input_proba "decimal value"]
```

## Arguments

- freq "*decimal value* [unit {Hz | KHz| MHz}]"  
Specifies the default frequency and units.
- proba {*decimal value*}  
Specifies the default probability.
- with "*vectorless | default*"  
Specifies vectorless or default analysis.
- input\_freq "*decimal value* [unit {Hz | KHz| MHz}]"  
Specifies the input frequency and units.
- input\_proba {*decimal value*}  
Specifies the input probability.

## Supported Families

IGLOO, ProASIC3, SmartFusion, Fusion, ProASIC<sup>PLUS</sup>, ProASIC, and Axcelerator

## Notes

- This command is associated with the functionality of [Initialize Frequencies and Probabilities](#) dialog box.

## Exceptions

- None

## Examples

The following example initializes all other sets after executing [smartpower\\_init\\_do](#) with `-othersets {true}`:

```
smartpower_init_set_othersets_options -freq {10 MHz} -proba {20} [-with default]
```

## smartpower\_init\_set\_primaryinputs\_options

Initializes the frequency and probability of all primary inputs.

```
smartpower_init_set_primaryinputs_options -freq {value} -proba {value}
```

## Arguments

- freq {*value*}  
Specifies the user input frequency (in Hz, KHz, or MHz) or the toggle rate (in %). If the unit is not provided and toggle rate is active, the value is handled as a toggle rate; if toggle rate is not active, the value is handled as a frequency.
- proba {*value*}  
Specifies the user input probability in %.

## Supported Families

IGLOO, ProASIC3, SmartFusion, Fusion, ProASIC<sup>PLUS</sup>, ProASIC, and Axcelerator

## Notes

- This command is associated with the functionality of [Initialize frequencies and probabilities](#) dialog box.

## Exceptions

- None

## Examples

The following example initializes all primary inputs after executing [smartpower\\_init\\_do](#) with `-primaryinputs {true}`:

```
smartpower_init_set_primaryinputs_options -freq {10 MHz} -proba {20}
```

## smartpower\_init\_set\_registers\_options

Initializes the frequency and probability of all register outputs.

```
smartpower_init_set_registers_options -freq {value} -proba {value}
```

## Arguments

`-freq {value}`

Specifies the user input frequency (in Hz, KHz, or MHz) or the toggle rate (in %). If the unit is not provided and toggle rate is active, the value is handled as a toggle rate; if toggle rate is not active, the value is handled as a frequency.

`-proba {value}`

Specifies the user input probability in %.

## Supported Families

IGLOO, ProASIC3, SmartFusion, Fusion, ProASIC<sup>PLUS</sup>, ProASIC, and Axcelerator

## Notes

- This command is associated with the functionality of [Initialize frequencies and probabilities](#) dialog box.

## Exceptions

- None

## Examples

The following example initializes all register outputs after executing [smartpower\\_init\\_do](#) with `-registers {true}`:

```
smartpower_init_set_registers_options -freq {10 MHz} -proba {20}
```

## smartpower\_init\_set\_set\_reset\_options

Initializes the frequency and probability of all set and reset nets.

```
smartpower_init_set_set_reset_options -freq {value} -proba {value}
```

### Arguments

-freq {value}

Specifies the user input frequency (in Hz, KHz, or MHz) or the toggle rate (in %). If the unit is not provided and toggle rate is active, the value is handled as a toggle rate; if toggle rate is not active, the value is handled as a frequency.

-proba {value}

Specifies the user input probability in %.

### Supported Families

IGLOO, ProASIC3, SmartFusion, Fusion, ProASIC<sup>PLUS</sup>, ProASIC, and Axcelerator

### Notes

- This command is associated with the functionality of [Initialize frequencies and probabilities](#) dialog box.

### Exceptions

- None

### Examples

The following example initializes all set/reset nets after executing [smartpower\\_init\\_do](#) with `-set_reset {true}`:

```
smartpower_init_set_set_reset_options -freq {10 MHz} -proba {20}
```

## smartpower\_remove\_all\_annotations

Removes all initialization annotations for the specified mode.

```
smartpower_remove_all_annotations -opmode {value}
```

### Arguments

-opmode {value}

Removes all initialization annotations for the specified mode.

### Supported Families

IGLOO, ProASIC3, SmartFusion, Fusion, ProASIC<sup>PLUS</sup>, ProASIC, and Axcelerator

## Notes

- This command is associated with the functionality of [Initialize frequencies and probabilities](#) dialog box.

## Exceptions

- None

## Examples

The following example initializes all clocks with:

```
smartpower_remove_all_annotations -opmode {my_mode}
```

## smartpower\_remove\_custom\_mode

Removes a custom mode.

```
smartpower_remove_custom_mode -name {deleted_mode_name}
```

## Arguments

-name {*deleted\_mode\_name*}

Specifies the name of the custom mode you want to delete.

## Supported Families

IGLOO, ProASIC3, SmartFusion, Fusion, ProASIC<sup>PLUS</sup>, ProASIC, and Axcelerator

## Notes

- None

## Exceptions

- None

## Examples

This example deletes custom mode "Cust\_1":

```
smartpower_delete_custom_mode -name {Cust_1}
```

### See Also

[sp\\_add\\_custom\\_mode](#)

[sp\\_edit\\_custom\\_mode](#)

## smartpower\_remove\_domain

Removes an existing clock or set domain.

```
smartpower_remove_domain -domain_type {value} -domain_name {domain_name}
```

## Arguments

`-domain_type {value}`

This specifies the type of domain to remove. The following table shows the acceptable values for this argument:

Value	Description
clock	The domain is a clock domain
set	The domain is a set domain

`-domain_name {domain_name}`

This specifies the name of the domain to remove

## Supported Families

IGLOO, ProASIC3, SmartFusion, Fusion, ProASIC<sup>PLUS</sup>, ProASIC, and Axcelerator

## Notes

The domain name must be the name of an existing domain.

The domain type must be either clock or set.

## Exceptions

None

## Examples

The following example removes the clock domain named "clk2":

```
smartpower_remove_domain -domain_type {clock} -domain_name {clk2}
```

The following example removes the set domain named "myset":

```
smartpower_remove_domain -domain_type {set} -domain_name {myset}
```

### See Also

[smartpower\\_create\\_domain](#)

## smartpower\_remove\_pin\_enable\_rate

**This command was obsoleted in SmartPower v8.5. Update your script to use [smartpower\\_remove\\_pin\\_probability](#) to remove the pin probability.**

**Note:** Note: The information below is obsolete and should only be used as reference when executing previously-created scripts. Update your scripts to use [smartpower\\_remove\\_pin\\_probability](#).

Removes the probability value associated with a specific pin. This pin will have a default probability based on the domain set it belongs to.

```
smartpower_remove_pin_enable_rate -pin_name {pin_name}
```

## Arguments

`-pin_name {pin_name}`

Specifies the name of the pin with the probability to remove. This pin must be the direct driver of an enable pin.

## Supported Families

IGLOO, ProASIC3, SmartFusion, Fusion, ProASIC<sup>PLUS</sup>, ProASIC, and Axcelerator

## Notes

- None

## Exceptions

- None

## Examples

The following example removes the probability of the pin driving the enable pin of a bidirectional I/O:

```
Smartpower_remove_pin_enable_rate -pin_name mybibuf/U0/U1:EOUT
```

## smartpower\_remove\_pin\_frequency

Removes the frequency associated with a specific pin. This pin will have a default frequency based on its domain.

```
smartpower_remove_pin_frequency -pin_name {pin_name}
```

## Arguments

`-pin_name {pin_name}`

Specifies the name of the pin for which the frequency will be removed.

## Supported Families

IGLOO, ProASIC3, SmartFusion, Fusion, ProASIC<sup>PLUS</sup>, ProASIC, and Axcelerator

## Notes

- The *pin\_name* must be the name of a pin that already exists in the design and already belongs to a domain.

## Exceptions

- None

## Examples

The following example removes the frequency from the pin named "count8\_clock":

```
smartpower_remove_pin_frequency -pin_name {count8_clock}
```



**See Also**[smartpower\\_set\\_pin\\_frequency](#)

## smartpower\_remove\_pin\_of\_domain

Removes a clock pin or a data pin from a clock or set domain, respectively.

```
smartpower_remove_pin_of_domain -pin_name {pin_name} -pin_type {value} -domain_name {domain_name} -domain_type {value}
```

### Arguments

-pin\_name {pin\_name}

Specifies the name of the pin to remove from the domain.

-pin\_type {value}

Specifies the type of the pin to remove. The following table shows the acceptable values for this argument:

Value	Description
clock	The pin to remove is a clock pin
data	The pinto remove is a data pin

-domain\_name {domain\_name}

Specifies the name of the domain from which to remove the pin.

-domain\_type {value}

Specifies the type of domain from which the pin is being removed. The following table shows the acceptable values for this argument:

Value	Description
clock	The domain is a clock domain
set	The domain is a set domain

### Supported Families

IGLOO, ProASIC3, SmartFusion, Fusion, ProASIC<sup>PLUS</sup>, ProASIC, and Axcelerator

### Notes

- The domain name must be the name of an existing domain.
- The pin name must be the name of an existing pin.

## Exceptions

- None

## Examples

The following example removes the clock pin named "XCMP3/U0/U1:Y" from the clock domain named "clockh":

```
smartpower_remove_pin_of_domain -pin_name {XCMP3/U0/U1:Y}
-pin_type {clock} -domain_name {clockh} -domain_type {clock}
```

The following example removes the data pin named "count2\_en" from the set domain named "InputSet":

```
smartpower_remove_pin_of_domain -pin_name {count2_en} -pin_type
{data} -domain_name {InputSet} -domain_type {set}
```

### See Also

[smartpower\\_add\\_pin\\_in\\_domain](#)

## smartpower\_remove\_pin\_probability

Removes the probability value associated with a specific pin. This pin will have a default probability based on the domain set it belongs to.

```
smartpower_remove_pin_probability -pin_name {pin_name}
```

## Arguments

`-pin_name` {*pin\_name*}

Specifies the name of the pin with the probability to remove. This pin must be the direct driver of an enable pin.

## Supported Families

IGLOO, ProASIC3, SmartFusion, Fusion, ProASIC<sup>PLUS</sup>, ProASIC, and Axcelerator

## Notes

- None

## Exceptions

- None

## Examples

The following example removes the probability of the pin driving the enable pin of a bidirectional I/O:

```
Smartpower_remove_pin_probability -pin_name mybibuf/U0/U1:EOUT
```

### See Also

[smartpower\\_set\\_pin\\_probability](#)

## smartpower\_remove\_scenario

Removes a scenario from the current design.

```
smartpower_remove_scenario -name {value}
```

### Arguments

-name {value}

Specifies the name of the scenario.

### Supported Families

IGLOO, ProASIC3, SmartFusion, Fusion, ProASIC<sup>PLUS</sup>, ProASIC, and Axcelerator

### Notes

- None

### Exceptions

- None

### Examples

This example removes a scenario from the current design:

```
smartpower_remove_scenario -name myscenario
```

## smartpower\_remove\_vcd

Removes an existing VCD file from a mode or entire design.

```
smartpower_remove_vcd -from {value} -mode {value} -file
```

### Arguments

-from {value}

This specifies the if the VCD is removed for a specific mode or for the entire project. The following table shows the acceptable values for this argument:

Value	Description
mode	The VCD file is removed for a mode
project	The VCD file is removed from the project

-mode {value}

This specifies the name of the mode for which the VCD will be removed

-filename

This specifies the name of the VCD file to be removed

## Supported Families

IGLOO, ProASIC3, SmartFusion, Fusion, ProASIC<sup>PLUS</sup>, ProASIC, and Axcelerator

## Notes

None

## Exceptions

None

## Examples

The following example removes the VCD file named *my\_vcd.vcd* from the active mode

```
smartpower_remove_vcd -from {mode} -mode {active} -my_vcd.vcd
```

### See Also

[smartpower\\_create\\_domain](#)

## smartpower\_restore

Restores all power information previously committed in SmartPower.

```
smartpower_restore
```

## Arguments

- None

## Supported Families

IGLOO, ProASIC3, SmartFusion, Fusion, ProASIC<sup>PLUS</sup>, ProASIC, and Axcelerator

## Notes

- None

## Exceptions

- None

## Examples

```
smartpower_restore
```

### See Also

[smartpower\\_commit](#)

## smartpower\_set\_battery\_capacity

Sets the battery capacity.

```
smartpower_set_battery_capacity {value}
```

### Arguments

*value*

Sets the battery capacity to a value in mA/h.

### Supported Families

IGLOO, ProASIC3, SmartFusion, Fusion, ProASIC<sup>PLUS</sup>, ProASIC, and Axcelerator

### Notes

- None

### Exceptions

- None

### Examples

The following example sets the battery capacity to 40 A/h:

```
smartpower_set_battery_capacity {40}
```

## smartpower\_set\_cooling

Sets the cooling style to one of the predefined types, or a custom value.

```
smartpower_set_cooling -style {value} -teta {value}
```

### Arguments

`-style {value}`

Specifies the cooling style to custom value or to one of the predefined types with a default thermal resistance value. The following table shows the acceptable values for this argument:

Value	Description
300_lfm	Predefined cooling style
case_cooling	Predefined cooling style
still_air	Predefined cooling style
custom	Cooling style defined by user input

-teta {*value*}

Specifies the thermal resistance in °C/W. This argument is only available when style is set to Custom.

## Supported Families

IGLOO, ProASIC3, SmartFusion, Fusion, ProASIC<sup>PLUS</sup>, ProASIC, and Axcelerator

## Notes

- To compute the junction temperature, set the following three commands: [smartpower\\_set\\_thermalmode](#), [smartpower\\_set\\_tambient](#) and [smartpower\\_set\\_cooling](#). The junction temperature will be updated when an output command is executed, such as report(Power).

## Exceptions

- None

## Examples

The following example sets the cooling style to still air:

```
smartpower_set_cooling -style {still_air}
```

## smartpower\_set\_mode\_for\_analysis

Sets the mode for cycle-accurate power analysis.

```
smartpower_set_mode_for_analysis -mode {value}
```

## Arguments

-mode {*value*}

Specifies the mode for cycle-accurate power analysis.

## Supported Families

IGLOO, ProASIC3, SmartFusion, Fusion, ProASIC<sup>PLUS</sup>, ProASIC, and Axcelerator

## Notes

- None

## Exceptions

- None

## Examples

The following example sets the mode for analysis to active:

```
smartpower_set_mode_for_analysis -mode {active}
```

## smartpower\_set\_operating\_condition

Sets the operating conditions used in SmartPower to one of the pre-defined types.

```
smartpower_set_operating_condition -opcond {value}
```

### Arguments

-opcond {value}

Specifies the value of the operating condition. The following table shows the acceptable values for this argument:

Value	Description
best	Sets the operating conditions to best
typical	Sets the operating conditions to typical
worst	Sets the operating conditions to worst

### Supported Families

IGLOO, ProASIC3, SmartFusion, Fusion, ProASIC<sup>PLUS</sup>, ProASIC, and Axcelerator

### Notes

- None

### Exceptions

- None

### Examples

This example sets the operating conditions to best:

```
smartpower_set_operating_condition -opcond {best}
```

### smartpower\_set\_pin\_enable\_rate

**This command was obsoleted in SmartPower v8.5. Update your script to use [smartpower\\_set\\_pin\\_probability](#) to set the pin probability.**

**Note:** Note: The information below is obsolete and should only be used as reference when executing previously-created scripts. Update your scripts to use [smartpower set pin probability](#).

Enables you to set the probability value of a pin driving an enable pin. For I/Os, if you do not use this command, the probability of the IOEnableSet is used. For memories, if you do not use this command, the probability of the MemoriesEnableSet is used.

```
smartpower_set_pin_enable_rate -pin_name {pin_name} -pin_enable_rate {value}
```

## Arguments

`-pin_name` {pin\_name}

Specifies the name of a pin for which the probability will be set. This pin must be the direct driver of an enable pin.

`-pin_enable_rate` {value}

Specifies the value of the pin probability as a percentage, which can be any positive decimal between 0 and 100, inclusive.

## Supported Families

IGLOO, ProASIC3, SmartFusion, Fusion, ProASIC<sup>PLUS</sup>, ProASIC, and Axcelerator

## Notes

- None

## Exceptions

- None

## Examples

The following example sets the probability of the pin driving the enable pin of a bidirectional I/O

```
smartpower_set_pin_enable_rate -pin_name mybibuf/U0/U1:EOUT \
-pin_enable_rate 50.4
```

## smartpower\_set\_pin\_frequency

Sets the frequency of a pin in megahertz (MHz). If you do not use this command, each pin will have default frequency based on its domain.

```
smartpower_set_pin_frequency -pin_name {pin_name} -pin_freq {value}
```

## Arguments

`-pin_name` {pin\_name}

Specifies the name of the pin for which the frequency will be set.

`-pin_freq` {value}

Specifies the value of the frequency in MHz, which can be any positive decimal number.

## Supported Families

IGLOO, ProASIC3, SmartFusion, Fusion, ProASIC<sup>PLUS</sup>, ProASIC, and Axcelerator



## Notes

- The *pin\_name* must be the name of a pin that already exists in the design and already belongs to a domain.
- When specifying the unit, a space must be between the frequency value and the unit.

## Exceptions

- None

## Examples

This example sets the frequency of the pin named "count8\_clock" to 100 MHz:

```
smartpower_set_pin_frequency -pin_name {count8_clock} -pin_freq {100}
```

### See Also

[smartpower\\_remove\\_pin\\_frequency](#)

## smartpower\_set\_preferences

Sets the following preferences: power unit, frequency unit, operating mode, operating conditions, and toggle. These preferences can also be set from the [preferences dialog box](#).

```
smartpower_set_preferences -powerunit {value} -frequnit {value} -opmode {value} -opcond {value} -toggle {value}
```

## Arguments

`-powerunit {value}`

Specifies the unit in which power is set. The following table shows the acceptable values for this argument:

Value	Description
W	The power unit is set to watts
mW	The power unit is set to milliwatts
uW	The power unit is set to microwatts

`-frequnit {value}`

Specifies the unit in which frequency is set. The following table shows the acceptable values for this argument:

Value	Description
Hz	The frequency unit is set to hertz
kHz	The frequency unit is set to kilohertz
MHz	The frequency unit is set to megahertz

`-opmode {value}`

Specifies the operating mode. The following table shows the acceptable values for this argument:

Value	Description
active	The operating mode is set to active
static	The operating mode is set to static
sleep	The operating mode is set to sleep
Flash*Freeze	The operating mode is set to Flash*Freeze
shutdown	The operating mode is set to shutdown

`-opcond {value}`

Specifies the operating condition. The following table shows the acceptable values for this argument:

Value	Description
worst	The operating condition is set to worst case
typical	The operating condition is set to typical case
best	The operating condition is set to best case

`-toggle {value}`

Specifies the toggle. The following table shows the acceptable values for this argument:

Value	Description
true	The toggle is set to true
false	The toggle is set to false

## Supported Families

IGLOO, ProASIC3, SmartFusion, Fusion, ProASIC<sup>PLUS</sup>, ProASIC, and Axcelerator

## Notes

- The following arguments have been removed. Running the script will trigger a warning message: Warning: Invalid argument: -argname "argvalue" Ignored. Ignore the warning.

- maxblocks {integer > 0}
- maxpins [{integer > 0}
- sortorder {ascending, descending}
- sortby {powervalues, alphabetical}
- Flash\*Freeze, Sleep, and Shutdown are available only for certain families and devices.
- Worst and Best operating conditions are available only for certain families and devices.

## Exceptions

- None

## Examples

This example sets the frequency of the power unit to "watts", the frequency unit to "Hz", the operating mode to "active", the operating condition to "typical", and the toggle to "true":

```
smartpower_set_setpreferences -powerunit {w} -frequnit {hz} -opmode {active} -opcond {typical} -toggle {true}
```

### See Also

[SmartPower Preferences](#)

# smartpower\_set\_scenario\_for\_analysis

Sets the scenario for cycle-accurate power analysis.

```
smartpower_set_scenario_for_analysis -scenario{value}
```

## Arguments

- scenario {value}
- Specifies the mode for cycle-accurate power analysis.

## Supported Families

IGLOO, ProASIC3, SmartFusion, Fusion, ProASIC<sup>PLUS</sup>, ProASIC, and Axcelerator

## Notes

- None

## Exceptions

- None

## Examples

The following example sets the scenario for analysis to my\_scenario:

```
smartpower_set_scenario_for_analysis -scenario {my_scenario}
```

## smartpower\_set\_temperature\_opcond

Sets the temperature in the operating conditions to one of the pre-defined types.

```
smartpower_set_temperature_opcond -use{value}
```

### Arguments

-use{value}

Specifies the temperature in the operating conditions. The following table shows the acceptable values for this argument:

Value	Description
oprange	Sets the temperature in the operating conditions as specified in the Device Selection Wizard in Designer
design	Sets the temperature in the operating conditions as specified in the SmartPower design-wide operating range. Applies to SmartPower only.
mode	Sets the temperature in the operating conditions as specified in the SmartPower mode-specific operating range. Applies to SmartPower only.

### Supported Families

IGLOO, ProASIC3, SmartFusion, Fusion, ProASIC<sup>PLUS</sup>, ProASIC, and Axcelerator

### Notes

- None

### Exceptions

- None

### Examples

This example sets the temperature in the operating conditions as specified in the custom mode-settings:

```
smartpower_set_temperature_opcond -use{mode}
```

## smartpower\_set\_thermalmode

Sets the mode of computing junction temperature.

```
smartpower_set_thermalmode -mode {value}
```

## Arguments

-mode {*value*}

Specifies the mode in which the junction temperature is computed. The following table shows the acceptable values for this argument:

Value	Description
ambient	The junction temperature will be iteratively computed with total static power
opcond	The junction temperature will be given as one of the operating condition range values specified in the device selection

## Supported Families

IGLOO, ProASIC3, SmartFusion, Fusion, ProASIC<sup>PLUS</sup>, ProASIC, and Axcelerator

## Notes

- To compute the junction temperature, set the following three commands: [smartpower set thermalmode](#), [smartpower set tambient](#) and [smartpower set cooling](#). The junction temperature will be updated when an output command is executed, such as [report\(Power\)](#).

## Exceptions

- None

## Examples

The following example sets the computing of the junction temperature to ambient mode:

```
smartpower_set_thermalmode -mode {ambient}
```

## smartpower\_set\_voltage\_opcond

Sets the voltage in the operating conditions.

```
smartpower_set_voltage_opcond -voltage{value} -use{value}
```

## Arguments

-voltage{*value*}

Specifies the voltage supply in the operating conditions. The following table shows the acceptable values for this argument:

Value	Description
VCCA	Sets the voltage operating conditions for VCCA

Value	Description
VCCI 3.3	Sets the voltage operating conditions for VCCI 3.3
VCCI 2.5	Sets the voltage operating conditions for VCCI 2.5
VCCI 1.8	Sets the voltage operating conditions for VCCI 1.8
VCCI 1.5	Sets the voltage operating conditions for VCCI 1.5
VCC33A	Sets the voltage operating conditions for VCC33A
VCCDA	Sets the voltage operating conditions for VCCDA

-use{*value*}

Specifies the voltage in the operating conditions for each voltage supply. The following table shows the acceptable values for this argument:

Value	Description
oprange	Sets the voltage in the operating conditions as specified in the Device Selection Wizard in Designer
design	Sets the voltage in the operating conditions as specified in the SmartPower design-wide operating range. Applies to SmartPower only.
mode	Sets the voltage in the operating conditions as specified in the SmartPower mode-specific operating range. Applies to SmartPower only.

## Supported Families

IGLOO, ProASIC3, SmartFusion, Fusion, ProASIC<sup>PLUS</sup>, ProASIC, and Axcelerator

## Notes

- None

## Exceptions

- None

## Examples

This example sets the VCCA as specified in the SmartPower mode-specific settings:

```
smartpower_set_voltage_opcond -voltage{vcca} -use{mode}
```

## smartpower\_temperature\_opcond\_set\_design\_wide

Sets the temperature for SmartPower design-wide operating conditions.

```
smartpower_temperature_opcond_set_design_wide -best{value} -typical{value} -worst{value} -
thermal_mode{value}
```

## Arguments

-best{value}

Specifies the best temperature (in degrees Celsius) used for design-wide operating conditions.

-typical{value}

Specifies the typical temperature (in degrees Celsius) used for design-wide operating conditions.

-worst{value}

Specifies the worst temperature (in degrees Celsius) used for design-wide operating conditions.

-thermal\_mode{value}

Specifies the mode in which the junction temperature is computed. The following table shows the acceptable values for this argument:

Value	Description
ambient	The junction temperature will be iteratively computed with total static power
opcond	The junction temperature will be given as one of the operating condition range values specified in the device selection

## Supported Families

IGLOO, ProASIC3, SmartFusion, Fusion, ProASIC<sup>PLUS</sup>, ProASIC, and Axcelerator

## Notes

- None

## Exceptions

- None

## Examples

This example sets the temperature for design-wide operating conditions to Best 20, Typical 30, and Worst 60:

```
smartpower_temperature_opcond_set_design_wide -best{20} -typical{30} -worst{60}
```

## smartpower\_temperature\_opcond\_set\_mode\_specific

Sets the temperature for SmartPower mode-specific operating conditions.

```
smartpower_temperature_opcond_set_mode_specific -mode{value} -best{value} -typical{value} -worst{value} -thermal_mode{value}
```

### Arguments

-mode{value}

Selects the mode to which apply the operating condition settings. You can select a pre-defined mode or any custom mode in your design.

-best{value}

Specifies the best temperature (in degrees Celsius) for the selected mode.

-typical{value}

Specifies the typical temperature (in degrees Celsius) for the selected mode.

-worst{value}

Specifies the worst temperature (in degrees Celsius) for the selected mode.

-thermal\_mode{value}

Specifies the mode in which the junction temperature is computed. The following table shows the acceptable values for this argument:

Value	Description
ambient	The junction temperature will be iteratively computed with total static power
opcond	The junction temperature will be given as one of the operating condition range values specified in the device selection

### Supported Families

IGLOO, ProASIC3, SmartFusion, Fusion, ProASIC<sup>PLUS</sup>, ProASIC, and Axcelerator

### Notes

- None

### Exceptions

- None

### Examples

This example sets the temperature for mode-specific operating conditions for mode1:



```
smartpower_temperature_opcond_set_mode_specific -mode{mode1} -best{20} -typical{30} -
worst{60}
```

## smartpower\_voltage\_opcond\_set\_design\_wide

Sets the voltage settings for SmartPower design-wide operating conditions.

```
smartpower_voltage_opcond_set_design_wide -voltage{value} -best{value} -typical{value} -
worst{value}
```

### Arguments

`-voltage{value}`

Specifies the voltage supply in the operating conditions. The following table shows the acceptable values for this argument:

Value	Description
VCCA	Sets the voltage operating conditions for VCCA
VCCI 3.3	Sets the voltage operating conditions for VCCI 3.3
VCCI 2.5	Sets the voltage operating conditions for VCCI 2.5
VCCI 1.8	Sets the voltage operating conditions for VCCI 1.8
VCCI 1.5	Sets the voltage operating conditions for VCCI 1.5
VCC33A	Sets the voltage operating conditions for VCC33A
VCCDA	Sets the voltage operating conditions for VCCDA

`-best{value}`

Specifies the best voltage used for design-wide operating conditions.

`-typical{value}`

Specifies the typical voltage used for design-wide operating conditions.

`-worst{value}`

Specifies the worst voltage used for design-wide operating conditions.

### Supported Families

IGLOO, ProASIC3, SmartFusion, Fusion, ProASIC<sup>PLUS</sup>, ProASIC, and Axcelerator

### Notes

- None

## Exceptions

- None

## Examples

This example sets VCCA for design-wide to best 20, typical 30 and worst 40:

```
smartpower_voltage_opcond_set_design_wide -voltage{VCCA} -best{20} -typical{30} -
worst{40}
```

## smartpower\_voltage\_opcond\_set\_mode\_specific

Sets the voltage settings for SmartPower mode-specific use operating conditions.

```
smartpower_voltage_opcond_set_mode_specific -opmode{value} -voltage{value} -best{value} -
typical{value} -worst{value}
```

## Arguments

-opmode{value}

Selects the mode to which apply the operating condition settings. You can select a pre-defined mode or any custom mode in your design.

-voltage{value}

Specifies the voltage in the operating conditions. The following table shows the acceptable values for this argument:

Value	Description
VCCA	Sets the voltage operating conditions for VCCA
VCCI 3.3	Sets the voltage operating conditions for VCCI 3.3
VCCI 2.5	Sets the voltage operating conditions for VCCI 2.5
VCCI 1.8	Sets the voltage operating conditions for VCCI 1.8
VCCI 1.5	Sets the voltage operating conditions for VCCI 1.5
VCC33A	Sets the voltage operating conditions for VCC33A
VCCDA	Sets the voltage operating conditions for VCCDA

-best{value}

Specifies the best voltage used for mode-specific operating conditions.

-typical{value}

Specifies the typical voltage used for mode-specific operating conditions.

-worst{value}

Specifies the worst voltage used for mode-specific operating conditions.

## Supported Families

IGLOO, ProASIC3, SmartFusion, Fusion, ProASIC<sup>PLUS</sup>, ProASIC, and Axcelerator

## Notes

- None

## Exceptions

- None

## Examples

This example sets the voltage for the static mode and sets best to 20, typical to 30 and worst to 40:

```
smartpower_voltage_opcond_set_mode_specific -opmode{active} -voltage{VCCA} -best{20} -
typical{30} -worst{40}
```

## st\_commit

Saves the changes made in SmartTime to the design (.adb) file

```
st_commit
```

## Arguments

None

## Supported Families

IGLOO, ProASIC3, SmartFusion, Fusion, ProASIC<sup>PLUS</sup>, ProASIC, and Axcelerator

## Exceptions

None

## Examples

```
st_commit
```

### See Also

[st\\_restore](#)

[Tcl documentation conventions](#)

## st\_create\_set

Creates a set of paths to be analyzed. Use the arguments to specify which paths to include. To create a set that is a subset of a clock domain, specify it with `-clock` and `-type`. To create a set that is a subset of an inter-clock domain

set, specify it with `-source_clock` and `-sink_clock`. To create a set that is a subset (filter) of an existing named set, specify the set to be filtered with `-from_set`.

To create a set that is not derived from an existing set, you must provide both the `-source` `pin_list` and `-sink` `pin_list` derived. Otherwise, the `-source` and `-sink` arguments act as filters on the pins from the parent set. You must give each new set a unique name in the design.

```
st_create_set -name name
[-parent_set name ]
[-clock clock_id -type value ]
[-in_to_out]
[-source_clock clock_id -sink_clock clock_id]
[-source pin_list ] -sink pin_list ]
```

## Arguments

`-name` *name*

Specifies a unique name for the newly create path set.

`-parent_set` *name*

Specifies the name of the set to filter.

`-clock` *clock\_id*

Specifies that the set is to be a subset of the given clock domain. This argument is valid only if you also specify the `-type` argument.

`-type` *value*

Specifies the predefined set type on which to base the new path set. You can only use this argument with the `-clock` argument, not by itself.

Value	Description
reg_to_reg	Paths between registers in the design
async_to_reg	Paths from asynchronous pins to registers
reg_to_async	Paths from registers to asynchronous pins
external_recovery	The set of paths from inputs to asynchronous pins
external_removal	The set of paths from inputs to asynchronous pins
external_setup	Paths from input ports to registers
external_hold	Paths from input ports to registers
clock_to_out	Paths from registers to output ports

`-in_to_out`

Specifies that the set is based on the “Input to Output” set, which includes paths that start at input ports and end at output ports.

`-source_clock` *clock\_id*

Specifies that the set will be a subset of an inter-clock domain set with the given source clock.

You can only use this option with the `-sink_clock` option, not by itself.

`-sink_clock` *clock\_id*

Specifies that the set will be a subset of an inter-clock domain set with the given sink clock.

You can only use this option with the `-source_clock` option, not by itself.

`-source` *pin\_list*

Specifies a filter on the source pins of the parent set. If you do not specify a parent set, this option filters all pins in the current design.

`-sink` *pin\_list*

Specifies a filter on the sink pins of the parent set. If you do not specify a parent set, this option filters all pins in the current design.

## Supported Families

IGLOO, ProASIC3, SmartFusion, Fusion, ProASIC<sup>PLUS</sup>, ProASIC, and Axcelerator

## Exceptions

None

## Examples

```
st_create_set -name { my_user_set } -source { C* } -sink { D* }
st_create_set -name { my_other_user_set } -from_set { my_user_set } -source { CL* }
st_create_set -name { adder } -clock { ALU_CLOCK } -type { REG_TO_REG } -sink { ADDER* }
st_create_set -name { another_set } -source_clock { EXTERN_CLOCK } -sink_clock { MY_GEN_CLOCK }
st_create_set -name { some_p2p } -pin2pin -to { T* }
```

## See Also

[Tcl documentation conventions](#)

[st\\_remove\\_set](#)

## st\_edit\_set

Modify the paths in a user set.

```
st_edit_set -name name
[-source pin_list ] [-sink pin_list ]
[-rename_to name ]
```

## Arguments

`-name` *name*

Specifies the name of the set to modify.

`-source pin_list`

If the set is a subset of another set, specifies a filter on the source pins from the parent set. Otherwise, this option specifies the source pins of the set.

`-sink pin_list`

If the set is a subset of another set, specifies a filter on the sink pins from the parent set. Otherwise, this option specifies the sink pins of the set.

`-rename_to name`

Specifies a new name for the set.

## Supported Families

IGLOO, ProASIC3, SmartFusion, Fusion, ProASIC<sup>PLUS</sup>, ProASIC, and Axcelerator

## Exceptions

None

## Examples

```
st_edit_set -name { my_user_set } -rename_to { my_critical_pins }
st_edit_set -name { adder } -sink { ADD* }
```

### See Also

[Tcl documentation conventions](#)

[st\\_create\\_set](#)

[st\\_remove\\_set](#)

## st\_expand\_path

Displays expanded path information (path details) for paths. The paths to be expanded are identified by the parameters required to display these paths with `st_list_paths`. For example, to expand the first path listed with `st_list_paths -clock {MYCLOCK} -type {register_to_register}`, use the command `st_expand_path -clock {MYCLOCK} -type {register_to_register}`. Path details contain the pin name, type, net name, cell name, operation, delay, total delay, and edge as well as the arrival time, required time, and slack. These details are the same as details available in the SmartTime Expanded Path window.

```
st_expand_path [-set name]
[-clock clock_id -type value]
[-in_to_out]
[-source_clock clock_id -sink_clock clock_id]
[-source pin_list] [-sink pin_list]
[-analysis value]
[-index list_of_indices]
[-format value]
```

## Arguments

`-set name`

Displays a list of paths from the named set. You can either use the `-set` option to specify a set name, or use both `-clock` and `-type` to specify a set. A list of valid set names includes "in\_to\_out", as well as any user set names.

`-clock` *clock\_id*

Displays the set of paths belonging to the specified clock domain. You can either use this option along with `-type` to specify a set or use the `-set` option to specify the name of the set to display.

`-in_to_out`

Specifies that the paths should be from the set "Input to Output, which includes paths that start at input ports and end at output ports.

`-type` *value*

Specifies the type of paths in the clock domain to display in a list. You can only use this option with the `-clock` option, not by itself. You can either use this option along with `-clock` to specify a set or use the `-set` option to specify a set name.

Value	Description
reg_to_reg	Paths between registers in the design
async_to_reg	Paths from asynchronous pins to registers
reg_to_async	Paths from registers to asynchronous pins
external_recovery	The set of paths from inputs to asynchronous pins
external_removal	The set of paths from inputs to asynchronous pins
external_setup	Paths from input ports to registers
	Paths from input ports to registers
clock_to_out	Paths from registers to output ports

`-source_clock` *clock\_id*

Displays a list of timing paths for an inter-clock domain set belonging to the source clock specified. You can only use this option with the `-sink_clock` option, not by itself.

`-sink_clock` *clock\_id*

Displays a list of timing paths for an inter-clock domain set belonging to the sink clock specified. You can only use this option with the `-source_clock` option, not by itself.

`-source` *pin\_list*

Specifies a filter on the source pins of the paths to be listed.

`-sink` *pin\_list*

Specifies a filter on the sink pins of the paths to be listed.

`-analysis` *name*

Specifies the analysis type for the paths to be listed. The following table shows the acceptable values for this argument:

Value	Description
-------	-------------

Value	Description
maxdelay	Maximum delay analysis
mindelay	Minimum delay analysis

-index *list\_of\_indices*

Specifies which paths to display. The index starts at 1 and defaults to 1. Only values lower than the max\_paths option will be expanded.

-format *value*

Specifies the file format of the output. The following table shows the acceptable values for this argument:

Value	Description
text	ASCII text format
csv	Comma separated value file format

## Supported Families

IGLOO, ProASIC3, SmartFusion, Fusion, ProASIC<sup>PLUS</sup>, ProASIC, and Axcelerator

## Exceptions

None

## Examples

**Note:** The following example returns a list of five paths:

```
st_expand_path -clock { myclock } -type {reg_to_reg }
st_expand_path -clock {myclock} -type {reg_to_reg} -index { 1 2 3 } -format text
```

## See Also

[Tcl documentation conventions](#)

[st\\_list\\_paths](#)

## st\_list\_paths

Displays the list of paths in the same tabular format shown in SmartTime.

```
st_list_paths [-set name ]
[-clock clock_id -type value ]
[-in_to_out]
[-source_clock clock_id -sink_clock clock_id]
[-source pin_list ] [-sink pin_list ]
```



```
[-analysis value ]
[-format value ]
```

## Arguments

`-set name`

Displays a list of paths from the named set. You can either use the `-set` option to specify a set name, or use both `-clock` and `-type` to specify a set. A list of valid set names includes “in\_to\_out”, as well as any user set names.

`-clock clock_id`

Displays the set of paths belonging to the specified clock domain. You can either use this option along with `-type` to specify a set or use the `-set` option to specify the name of the set to display.

`-in_to_out`

Specifies that the paths should be from the set “Input to Output”, which includes paths that start at input ports and end at output ports.

`-type value`

Specifies the type of paths in the clock domain to display in a list. You can only use this option with the `-clock` option, not by itself. You can either use this option along with `-clock` to specify a set or use the `-set` option to specify a set name.

Value	Description
reg_to_reg	Paths between registers in the design
async_to_reg	Paths from asynchronous pins to registers
reg_to_async	Paths from registers to asynchronous pins
external_recovery	The set of paths from inputs to asynchronous pins
external_removal	The set of paths from inputs to asynchronous pins
external_setup	Paths from input ports to registers
	Paths from input ports to registers
clock_to_out	Paths from registers to output ports

`-source_clock clock_id`

Displays a list of timing paths for an inter-clock domain set belonging to the source clock specified. You can only use this option with the `-sink_clock` option, not by itself.

`-sink_clock clock_id`

Displays a list of timing paths for an inter-clock domain set belonging to the sink clock specified. You can only use this option with the `-source_clock` option, not by itself.

`-source pin_list`

Specifies a filter on the source pins of the paths to be listed.

`-sink pin_list`

Specifies a filter on the sink pins of the paths to be listed.

-analysis *name*

Specifies the analysis type for the paths to be listed. The following table shows the acceptable values for this argument:

Value	Description
maxdelay	Maximum delay analysis
mindelay	Minimum delay analysis

-format *value*

Specifies the file format of the output. The following table shows the acceptable values for this argument:

Value	Description
text	ASCII text format
csv	Comma separated value file format

## Supported Families

IGLOO, ProASIC3, SmartFusion, Fusion, ProASIC<sup>PLUS</sup>, ProASIC, and Axcelerator

## Exceptions

None

## Examples

```
st_list_paths -set { myset }
st_list_paths -analysis mindelay -clock { myclock } -type { reg_to_reg } -format csv
```

The list of paths can be written to a file with the following Tcl commands:

```
set outfile [ open "pathlisting.csv" w ]
puts $outfile [ st_list_paths -format csv -set { myset} ]
close $outfile
```

### See Also

[Tcl documentation conventions](#)

[st\\_expand\\_path](#)

## st\_remove\_set

Deletes a user set from the design.

```
st_remove_set -name name
```

## Arguments

-name *name*

Specifies the name of the set to delete.

## Supported Families

IGLOO, ProASIC3, SmartFusion, Fusion, ProASIC<sup>PLUS</sup>, ProASIC, and Axcelerator

## Exceptions

None

## Examples

```
st_remove_set { clockset1 }
```

### See Also

[Tcl documentation conventions](#)

[st\\_create\\_set](#)

# st\_restore

Restores constraints previously committed in SmartTime.

```
st_restore
```

## Arguments

None

## Supported Families

IGLOO, ProASIC3, SmartFusion, Fusion, ProASIC<sup>PLUS</sup>, ProASIC, Axcelerator, eX, and SX-A

## Exceptions

None

## Examples

```
st_restore
```

### See Also

[st\\_commit](#)

[Tcl documentation conventions](#)

## st\_set\_options

Sets options for timing analysis. With no parameters given, it will display the current settings of the options. For IGLOO, ProASIC3, SmartFusion, Fusion, ProASIC<sup>PLUS</sup>, and Axcelerator families, these options also affect timing-driven place-and-route.

```
st_set_options [-max_opcond value ]
[-min_opcond value]
[-interclockdomain_analysis value]
[-use_bibuf_loopbacks value]
[-enable_recovery_removal_checks value]
[-break_at_async value]
[-filter_when_slack_below value]
[-filter_when_slack_above value]
[-remove_slack_filters]
[-limit_max_paths value]
[-expand_clock_network value]
[-expand_parallel_paths value]
[-analysis_scenario value]
[-tdpr_scenario value]
[-reset]
```

### Arguments

`-max_opcond value`

Sets the operating condition to use for Maximum Delay Analysis. The following table shows the acceptable values for this argument:

Value	Description
worst	Use Worst Case conditions for Maximum Delay Analysis
typ	Use Typical conditions for Maximum Delay Analysis
best	Use Best Case conditions for Maximum Delay Analysis

`-min_opcond value`

Sets the operating condition to use for Minimum Delay Analysis. The following table shows the acceptable values for this argument:

Value	Description
best	Use Best Case conditions for Minimum Delay Analysis
typ	Use Typical conditions for Minimum Delay Analysis
worst	Use Worst Case conditions for Minimum Delay Analysis

-interclockdomain\_analysis *value*

Enables or disables inter-clock domain analysis.

Value	Description
yes	Enables inter-clock domain analysis
no	Disables inter-clock domain analysis

-use\_bibuf\_loopbacks *value*

Enables or disables loopback in bibufs.

Value	Description
yes	Enables loopback in bibufs
no	Disables loopback in bibufs

-enable\_recovery\_removal\_checks *value*

Enables or disables recovery and removal checks.

Value	Description
yes	Enables recovery and removal checks
no	Disables recovery and removal checks

-break\_at\_async *value*

Enables or disables breaking paths at asynchronous ports.

Value	Description
yes	Enables breaking paths at asynchronous ports
no	Disables breaking paths at asynchronous ports

-filter\_when\_slack\_below *value*

Do not show paths with slack below x.

-filter\_when\_slack\_above *value*

Do not show paths with slack above y.

-remove\_slack\_filters

Remove all existing slack filters.

`-limit_max_paths` *value*

Limit path reporting commands to a maximum of <n> paths, where n is a value of 0 or higher.

`-expand_clock_network` *value*

Enables or disables expanded clock network information in expanded paths.

Value	Description
yes	Enables expanded clock network information in paths
no	Disables expanded clock network information in paths

`-expand_parallel_paths` *value*

Expand a maximum of <n> parallel paths, where n is a value of 0 or higher. If n is 0 or 1, only one path will be expanded when viewing expanded paths.

`-analysis_scenario` *value*

Set the timing constraints scenario to be used for both maximum delay and minimum delay analysis. The argument must be a valid scenario name.

**Note:** Note: This option does not affect the timing scenario used for TDPR.

`-tdpr_scenario` *value*

Set the timing constraints scenario to be used by the place and route engine. The argument must be a valid scenario name.

**Note:** Note: This option does not affect the timing scenario used for analysis.

`-reset`

Reset all options to their default values, except for scenarios used for analysis and TDPR that remain unchanged.

## Supported Families

IGLOO, ProASIC3, SmartFusion, Fusion, ProASIC<sup>PLUS</sup>, ProASIC, Axcelerator, eX, and SX-A

## Exceptions

None

## Examples

```
st_set_options -max_opcond worst \
-min_opcond best \
-interclockdomain_analysis true \
-enable_removal_recovery_checks true
st_set_options -limit_max_paths 50 -remove_slack_filters \
-filter_when_slack_above 3
```

## See Also

[Tcl documentation conventions](#)

## timer\_add\_clock\_exception

Adds an exception to or from a pin with respect to a specified clock.

```
timer_add_clock_exception -clock clock_name -pin pin_name -dir value
```

### Arguments

-clock *span* class="tcl\_value">*clock\_name*

Specifies the name of the clock.

-pin *pin\_name*

Specifies the exception on the pin in a synchronous network to be excluded from the specified clock period.

-dir *value*

Specifies direction.

Value	Description
from	Refers to paths starting at the specific pin.
to	Refers to paths ending at the specific pin.

### Supported Families

All

### Exceptions

- For the IGLOO, ProASIC3, SmartFusion, Fusion, ProASIC<sup>PLUS</sup>, ProASIC, Axcelerator, eX, and SX-Afamilies, the timing analysis tool translates this command to an equivalent SDC command `set_multicycle_path`.

### Examples

The following example adds a clock exception from the pin `reg_q_a_10_/U0:CLK` with respect to the clock `clk`.

```
timer_add_clock_exception -clock {clk} -pin {reg_q_a_10_/U0:CLK} -dir {from}
```

The following example adds a clock exception to the pin `reg_q_a_10_/U0:E` with respect to the clock `clk`.

```
timer_add_clock_exception -clock {clk} -pin {reg_q_a_10_/U0:E} -dir {to}
```

#### See Also

[timer\\_remove\\_clock\\_exception](#)

[set\\_multicycle\\_path](#)

[Tcl documentation conventions](#)

## timer\_add\_pass

Adds a pin to the list of pins that the path must be shown passing through in the timing analysis tool.

```
timer_add_pass -pin pin_name
```

## Arguments

-pin *pin\_name*

Specifies the name of the pin to be included for displaying the timing path through it.

## Supported Families

All

## Description

When you set a pass on a module pin, you can see a path through individual pins.

## Exceptions

- For the IGLOO, ProASIC3, SmartFusion, Fusion, ProASIC<sup>PLUS</sup>, ProASIC, Axcelerator, eX, and SX-A families, the timing analysis tool ignores the timer\_add\_pass command.

## Examples

This example adds a pass through the pin "reg\_q\_a\_0:CLK":

```
>timer_add_pass -pin {reg_q_a_0:CLK}
```

This example adds a pass through a clear pin "reg\_q\_a\_0:CLR":

```
timer_add_pass -pin {reg_q_a_0:CLR}
```

### See Also

[timer\\_add\\_stop](#)

[Tcl documentation conventions](#)

## timer\_add\_stop

Adds the specified pin to the list of pins through which the paths will not be displayed in the timing analysis tool.

```
timer_add_stop -pin pin_name
```

## Arguments

-pin *pin\_name*

Specifies the name of the pin through which the path will not be displayed.

## Supported Families

All



## Description

Without stop points, you see all paths from pad to pad in the design. If you do not want to see the paths going through register clock pins, you can specify these as stop points. The path going through the specified pins will not be displayed.

## Exceptions

- For the IGLOO, ProASIC3, SmartFusion, Fusion, ProASIC<sup>PLUS</sup>, ProASIC, Axcelerator, eX, and SX-A families, Actel recommends that you use the equivalent SDC command `set_false_path`.

## Examples

The following example adds a stop to the pin "a<2>":

```
timer_add_stop -pin {a<2>}
```

The following example adds a stop to a clock and the clear pin "reg\_q\_a\_0:CLR":

```
timer_add_stop -pin {reg_q_a_0:CLK}
timer_add_stop -pin {reg_q_a_0:CLR}
```

### See Also

- [timer\\_add\\_pass](#)
- [set\\_false\\_path \(SDC false path constraint\)](#)
- [Tcl documentation conventions](#)

# timer\_commit

Saves the changes made to constraints into the Designer database.

```
timer_commit
```

## Arguments

None

## Supported Families

All

## Exceptions

- For the IGLOO, ProASIC3, SmartFusion, Fusion, ProASIC<sup>PLUS</sup>, ProASIC, Axcelerator, eX, and SX-A families, Actel recommends that you use `import_source`. This automatically commits constraints to the design database.

## Examples

```
timer_commit
```

**See Also**[import\\_source](#)[timer\\_restore](#)[Tcl documentation conventions](#)

## timer\_get\_path

Displays the path between the specified pins in the Log window.

```

timer_get_path -from source_pin -to destination_pin
[-exp value]\
[-sort value]\
[-order value]\
[-case value]\
[-maxpath maximum_paths]\
[-maxexpath maximum_paths_to_expand]\
[-mindelay minimum_delay]\
[-maxdelay maximum_delay]\
[-breakatclk value]\
[-breakatclr value]

```

### Arguments

-from *source\_pin*

Specifies the name of the source pin for the path.

-to *destination\_pin*

Specifies the name of the destination pin for the path.

-exp *value*

Specifies whether to expand the path. The following table shows the acceptable values for this argument:

Value	Description
yes	Expands the path
no	Does not expand the path

-sort *value*

Specifies whether to sort the path by either the actual delay or slack value. The following table shows the acceptable values for this argument:

Value	Description
actual	Sorts the path by the actual delay value
slack	Sorts the path by the slack value

-order *value*

Specifies whether the list is based on maximum or minimum delay analysis. The following table shows the acceptable values for this argument:

Value	Description
long	The paths are listed based on the maximum delay analysis
short	The paths are listed based on the minimum delay analysis

-case *value*

Specifies whether the report will include the worst, typical, or best case timing numbers. The following table shows the acceptable values for this argument:

Value	Description
worst	Includes worst case timing numbers
typ	Includes typical case timing numbers
best	Includes best case timing numbers

-maxpath *maximum\_paths*

Specifies the maximum number of paths to display.

-maxexpath *maximum\_paths\_to\_expand*

Specifies the maximum number of paths to expand.

-mindelay *minimum\_delay*

Specifies the path delay in the minimum delay analysis mode.

-maxdelay *maximum\_delay*

Specifies the path delay in the maximum delay analysis mode.

-breakatclk *value*

Specifies whether to break the paths at the register clock pins. The following table shows the acceptable values for this argument:

Value	Description
yes	Breaks the paths at the register clock pins
no	Does not break the paths at the register clock pins

-breakatclr *value*

Specifies whether to break the paths at the register clear pins. The following table shows the acceptable values for this argument:

Value	Description
yes	Breaks the paths at the register clear pins

Value	Description
no	Does not break the paths at the register clear pins

## Supported Families

All

## Exceptions

None

## Examples

The following example returns the paths from input port `headdr_dat<31>` to the input pin of register `u0_headdr_data1_reg/data_out_t_31` under typical conditions.

```
timer_get_path -from "headdr_dat<31>" \
-to "u0_headdr_data1_reg/data_out_t_31/U0:D" \
-case typ \
-exp "yes" \
-maxpath "100" \
-maxexpapth "10"
```

The following example returns the paths from the clock pin of register `gearbox_inst/bits64_out_reg<55>` to the output port `pma_tx_data_64bit[55]`

```
timer_get_path -from "gearbox_inst/bits64_out_reg<55>/U0:CLK" \
-to {pma_tx_data_64bit[55]} \
-exp "yes"
```

### See Also

[Tcl documentation conventions](#)

## timer\_get\_clock\_actuals

Displays the actual clock frequency in the Log window, when the timing analysis tool is initiated.

```
timer_get_clock_actuals -clock clock_name
```

## Arguments

-clock *clock\_name*

Specifies the name of the clock with the frequency (or period) to display.

## Supported Families

All

## Exceptions

None

## Examples

This example displays the actual clock frequency of clock clk1 in the Log window:

```
timer_get_clock_actuals -clock clk1
```

### See Also

[timer\\_get\\_clock\\_constraints](#)

[Tcl documentation conventions](#)

# timer\_get\_clock\_constraints

Returns the constraints (period, frequency, and duty cycle) on the specified clock.

```
timer_get_clock_constraints -clock clock_name
```

## Arguments

-clock *clock\_name*

Specifies the name of the clock with the constraint to display.

## Supported Families

All

## Exceptions

None

## Examples

The following example displays the clock constraints on the clock clk in the Log window:

```
timer_get_clock_constraints -clock clk
```

### See Also

[timer\\_get\\_clock\\_actuals](#)

[Tcl documentation conventions](#)

# timer\_get\_maxdelay

Displays the maximum delay constraint between two pins in a path in the Log window.

```
timer_get_maxdelay -from source_pin -to destination_pin
```

## Arguments

-from *source\_pin*

Specifies the name of the source pin in the path.

-to *destination\_pin*

Specifies the name of the destination pin in the path.

## Supported Families

All

## Exceptions

None

## Examples

The following example displays the maximum delay constraint from the pin clk166 to the pin reg\_q\_a\_9\_/U0:CLK in the Log window:

```
timer_get_maxdelay -from {clk166} -to {reg_q_a_9_/U0:CLK}
```

### See Also

[timer\\_set\\_maxdelay](#)

[Tcl documentation conventions](#)

# timer\_get\_path\_constraints

Displays the path constraints that were set as the maximum delay constraint in the timing analysis tool.

```
timer_get_path_constraints
```

## Arguments

None

## Supported Families

All

## Description

This command lists the paths constrained by maximum delay values. The information is displayed in the Log window. If no maximum delay constraints are set, this command does not report anything.

## Exceptions

None

## Examples

Invoking `timer_get_path_constraints` displays the following paths and their delay constraints in the Log window:

```
max_delay -from [all_inputs] -to [all_outputs] = 12 ns
max_delay -from p_f_testwdata0 p_f_testwdata1 -to p_f_dacuwwdata0 p_f_dacuwwdata1
r_f_dacuwwdata0 r_f_dacuwwdata1 = 8 ns
```

### See Also

[timer\\_set\\_maxdelay](#)

[Tcl documentation conventions](#)

## timer\_remove\_clock\_exception

Removes the previously set clock constraint.

```
timer_remove_clock_exception -clock clock_name -pin pin_name -dir value
```

## Arguments

-clock *clock\_name*

Specifies the name of the clock from which to remove the constraint.

-pin *pin\_name*

Specifies the name of the pin to remove.

-dir *value*

Specifies direction.

Value	Description
from	Refers to paths starting at the specified pin.
to	Refers to paths ending at the specified pin.

## Supported Families

All

## Exceptions

- For the IGLOO, ProASIC3, SmartFusion, Fusion, ProASIC<sup>PLUS</sup>, ProASIC, Axcelerator, eX, and SX-A families, the timing analysis tool ignores the `timer_remove_clock_exceptions` command. To remove the clock exception, use the [Set Multicycle Constraint dialog box](#).

## Examples

This example removes a clock exception from the pin `reg_q_a_10_/U0:CLK` with respect to the clock `clk`:

```
timer_remove_clock_exception -clock {clk} -pin {reg_q_a_10_/U0:CLK} -dir {from}
```

This example removes a clock exception to the pin `reg_q_a_10_/U0:E` with respect to the clock `clk`:

```
timer_remove_clock_exception -clock {clk} -pin {reg_q_a_10_/U0:E} -dir {to}.
```

### See Also

[timer\\_add\\_clock\\_exception](#)

[Tcl documentation conventions](#)

[Set Multicycle Constraint dialog box](#)

## timer\_remove\_pass

Removes the previously entered path pass constraint.

```
timer_remove_pass -pin pin_name
```

### Arguments

-pin *pin\_name*

Specifies the name of the pin from which to remove the path pass constraint.

### Supported Families

All

### Exceptions

- For the IGLOO, ProASIC3, SmartFusion, Fusion, ProASIC<sup>PLUS</sup>, ProASIC, Axcelerator, eX, and SX-A families, the timing analysis tool ignores the timer\_remove\_pass command.

### Examples

The following example removes the pass constraint from the clock pin reg\_q\_a\_0\_:CLK:

```
timer_remove_pass -pin {reg_q_a_0_:CLK}
```

### See Also

[timer\\_add\\_pass](#)

[Tcl documentation conventions](#)

## timer\_remove\_stop

Removes the previously entered path stop constraint on the specified pin.

```
timer_remove_stop -pin pin_name
```

### Arguments

-pin *pin\_name*

Specifies the name of the pin from which to remove the path stop constraint.



## Supported Families

All

## Description

If you remove a path stop constraint using the Timer GUI, and then export a script using **File > Export > Script files**, the resulting script will contain `timer_remove_pass -pin pin_name` instead of `timer_remove_stop -pin pin_name`.

## Exceptions

- For the IGLOO, ProASIC3, SmartFusion, Fusion, ProASIC<sup>PLUS</sup>, ProASIC, Axcelerator, eX, and SX-A families, Actel recommends the following flow:
  - Open **SmartTime > Set False Path Constraint dialog box**.
  - Look for the pin name in the **Through:** list (Note: You must not have any entry selected in the **From** or **To** lists).
  - Delete this pin.

## Examples

The following example removes the path stop constraint on the clear pin `reg_q_a_0:CLR`:

```
timer_remove_stop -pin {reg_q_a_0:CLR}
```

### See Also

[timer\\_add\\_stop](#)

[Tcl documentation conventions](#)

[Set False Path Constraint dialog box](#)

## timer\_restore

Restores constraints previously committed in Timer.

```
timer_restore
```

## Arguments

None

## Supported Families

All

## Exceptions

None

## Examples

```
timer_restore
```

### See Also

[timer\\_commit](#)

[Tcl documentation conventions](#)

## timer\_setenv\_clock\_freq

Sets a required clock frequency for the specified clock in megahertz (MHz).

```
timer_setenv_clock_freq -clock clock_name -freq value [-dutycycle dutycycle]
```

## Arguments

-clock *clock\_name*

Specifies the name of the clock for which to set the required frequency.

-freq *value*

Specifies the frequency in MHz.

-dutycycle *dutycycle*

Specifies the duty cycle for the clock constraint.

## Supported Families

All

## Exceptions

- For the IGLOO, ProASIC3, SmartFusion, Fusion, ProASIC<sup>PLUS</sup>, ProASIC, Axcelerator, SX-S, SX-A, and eX families, Actel recommends that you use the equivalent SDC command `create_clock`.

## Examples

The following example sets a clock frequency of 100MHz on the clock `clk1`:

```
timer_setenv_clock_freq -clock {clk1} -freq 100.00
```

### See Also

[create\\_clock \(SDC clock constraint\)](#)

[Tcl documentation conventions](#)

[timer\\_setenv\\_clock\\_period](#)

## timer\_setenv\_clock\_period

Sets the clock period constraint on the specified clock.

```
timer_setenv_clock_period -clock clock_name \
[-unit {value}] -period period_value\
[-dutycycle dutycycle]
```

## Arguments

-clock *clock\_name*

Specifies the name of the clock for which to set the period.

-unit {*value*}

Specifies the unit for the clock period constraint. The default is ns. The following table shows the acceptable values for this argument:

Value	Description
ns	nanoseconds
ps	picoseconds

-period *period\_value*

Specifies the period in the specified unit.

-dutycycle *dutycycle*

Specifies the duty cycle for the clock constraint.

## Supported Families

All

## Exceptions

- For the IGLOO, ProASIC3, SmartFusion, Fusion, ProASIC<sup>PLUS</sup>, ProASIC, Axcelerator, SX-S, SX-A, and eX families, Actel recommends that you use the equivalent SDC command `create_clock`.

## Examples

The following example sets a clock period of 2.40ns on the clock `clk1`:

```
timer_setenv_clock_period -clock clk1 -unit {ns} -period 2.40
```

### See Also

[timer\\_setenv\\_clock\\_freq](#)

[Tcl documentation conventions](#)

## timer\_set\_maxdelay

Adds a maximum delay constraint to the specified path.

```
timer_set_maxdelay -from source_pin \  
-to destination_pin \  
[-unit {value}] -delay delay_value
```

## Arguments

-from *source\_pin*

Specifies the name of the source pin in the path.

-to *destination\_pin*

Specifies the name of the destination pin in the path.

-unit {*value*}

Specifies whether the delay unit is in nanoseconds or picoseconds. The following table shows the acceptable values for this argument:

Value	Description
ns	Sets the delay in nanoseconds
ps	Sets the delay in picoseconds

-delay *delay\_value*

Specifies the actual delay value for the path.

## Supported Families

All

## Exceptions

- For the IGLOO, ProASIC3, SmartFusion, Fusion, ProASIC<sup>PLUS</sup>, ProASIC, Axcelerator, SX-S, SX-A, and eX families, Actel recommends that you use the equivalent SDC command `set_max_delay`.

## Examples

The following example sets a maximum delay of 20 nanoseconds from register reg1 to output pin out1:

```
timer_set_maxdelay -from {reg1:CLK} -to {out1} -unit {ns} -delay 20.00
```

### See Also

[timer\\_get\\_maxdelay](#)

[set\\_max\\_delay \(SDC max path constraint\)](#)

[Tcl documentation conventions](#)

## timer\_remove\_all\_constraints

Removes all timing constraints in the current design.

```
timer_remove_all_constraints
```

## Arguments

None

## Supported Families

All

## Exceptions

None

## Examples

The following example removes all of the constraints from the design and then commits the changes:

```
timer_remove_all_constraints  
timer_commit
```

### See Also

[timer\\_commit](#)

[Tcl documentation conventions](#)

## use\_file

Specifies which file in your project to use.

```
use_file  
-file value  
-module value  
-designer_view value
```

## Arguments

-file *value*

Specifies the EDIF or ADB file you wish to use in the project. Value is the name of the file you wish use (including the full pathname).

-module *value*

Specifies the module in which you want to use the file.

-designer\_view *value*

Specifies the Designer View in which you wish to use the file.

## Supported Families

All

## Exceptions

- None

## Example

Specify file1.edn in the ./project/synthesis directory, in the module named top, in the Designer View named impl1.

```
use_file -file "./project/synthesis/file1.edn" -module "top" -designer_view "Impl1"
```

## See Also

[use\\_source\\_file](#)

## use\_source\_file

Defines a module for your project.

```
use_source_file  
-file value  
-module value
```

## Arguments

-file *value*

Specifies the Verilog or VHDL file. Value is the name of the file you wish use (including the full pathname).

-module *value*

Specifies the module in which you want to use the file.

## Supported Families

All

## Exceptions

None

## Example

Specify file1.vhd in the ./project/hdl directory, in the module named top.

```
use_source_file -file "./project/hdl/file1.vhd" -module "top"
```

## See Also

[use\\_file](#)

## Add or Edit profile Dialog Box

Use the Add or Edit profile dialog box to add a new tool or edit an existing tool profile.

This dialog box is read-only for predefined profiles.

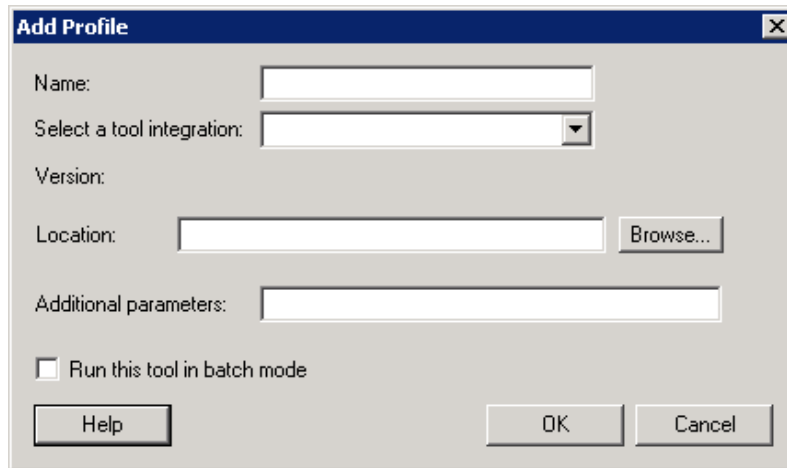

Figure 117 · Add Profile Dialog Box

**Name**

Enter the name for the tool. The name appears in the [Project Profiles](#) dialog box.

**Select a tool integration:** Select a tool from the drop down list of integrated tools.

**Version:** Lists your version of the selected tool.

**Location:** Enter the location of the tool, or click Browse and locate the project directory for the .exe file.

**Additional Parameters:** Enter additional arguments you want passed to the tool.

Click the checkbox to enable running the tool in batch mode.

To access this dialog, from the **Profile** dialog box, click **Add** or **Edit**.

**See Also**

[Profiles dialog box](#)

[Project profile](#)

## Project Manager - Cores Dialog Box (Advanced Download Mode)

This dialog box (shown below) enables you to download cores from a [web repository](#) into a Vault.

A Vault is a local directory (either local to your machine or on the local network) that contains cores downloaded from one or more repositories. A repository is a location on the web that contains cores that can be included in your design.

The Catalog displays all the cores in your Vault.

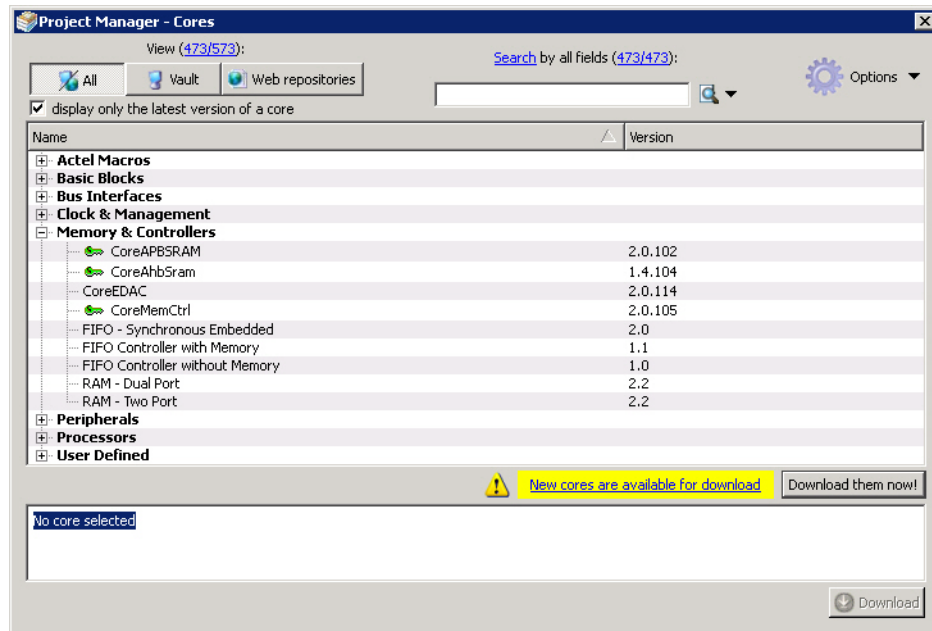

Figure 118 · Project Manager - Cores Dialog Box

**Display only the latest version of a core** is checked by default. This option, if checked, shows the latest versions of cores that are not in the Vault, and also filters out any duplicate cores that have the same Vendor, Library, and Name, with an earlier version number.

If the checkbox is de-selected the dialog box displays all cores, including those already loaded into the Vault. The status column indicates if a core has already been loaded.

Use the Filter to find any string that exists either in the core name or the Core Description. By default the filter contains a beginning and ending "\*", so if you type 'controller' you get all cores with controller in the core name (case insensitive search) or in the core description.

The colored icons indicate the license status. Blank means that the core is not license protected in any way. Colored icons means that the core is license protected, with the following meanings:

**Green Key** - Fully licensed; supports the entire design flow.

**Yellow Key** - Has a limited or evaluation license only. Precompiled simulation libraries are provided, enabling the core to be instantiated and simulated within the Actel Libero Integrated Design Environment (IDE). Using the Evaluation version of the core it is possible to create and simulate the complete design in which the core is being included. The design is not synthesizable (RTL code is not provided). No license feature in the license.dat file is needed to run the core in evaluation mode. You can purchase a license to generate an obfuscated or RTL netlist.

**Yellow Key with Red Circle** - License is protected; you are not licensed to use this core.

**Stop Downloads** - Interrupts the download for any cores being added to your Vault.



## Catalog Options Dialog Box

The Catalog Options dialog box (as shown below) enables you to customize your [Catalog display](#). You can add a repository, set the location of your vault, and change the View Settings for the Catalog. To display this dialog box, click the Catalog Options button .

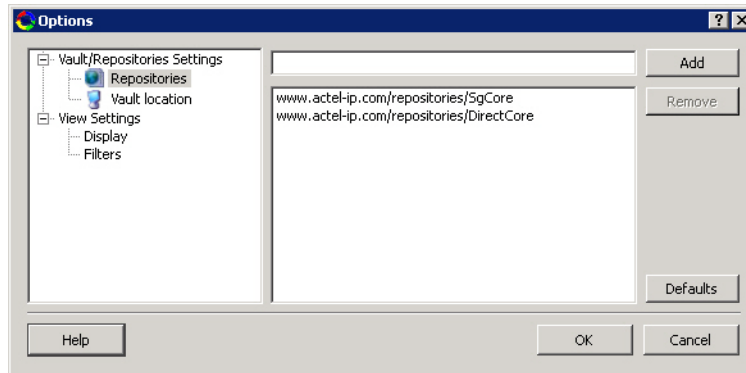

Figure 119 · Catalog Display Options Dialog Box

## Vault/Repositories Settings

### Repositories

A repository is a location on the web that contains cores that can be included in your design.

The Catalog Options dialog box enables you to specify which repositories you want to display in your [Vault](#). The Vault displays a list of cores from all your repositories, and the [Catalog](#) displays all the cores in your Vault.

The default repository cannot be permanently deleted; it is restored each time you open the Manage Repositories dialog box.

Any cores stored in the repository are listed by name in your Vault and Catalog; repository cores displayed in your Catalog can be filtered like any other core.

Type in the address and click the **Add** button to add new repositories. Click the **Remove** button to remove a repository (and its contents) from your Vault and Catalog. Removing a repository from the list removes the repository contents from your Vault.

### Vault location

Use this option to choose a new vault location on your local network. Enter the full domain pathname in the Select new vault location field. Use the format:

```
\\server\share
```

and the cores in your Vault will be listed in the Catalog.

## View Settings

### Display

**Group cores by function** - Displays a list of cores, sorted by function. Click any function to expand the list and view specific cores.

**List cores alphabetically** - Displays an expanded list of all cores, sorted alphabetically. Double click a core to configure it. This view is often the best option if you are using the filters to customize your display.

**Show core version** - Shows/hides the core version.

### Filters

**Filter field** - Type text in the Filter Field to display only cores that match the text in your filter. For example, to view cores that include 'sub' in the name, set the Filter Field to **Name** and type **sub**.

**Display only latest version of a core** - Shows/hides older versions of cores; this feature is useful if you are designing with an older family and wish to use an older core.

**Show all local and remote cores** - Displays all cores in your Catalog.

**Show local cores only** - Displays only the cores in your local vault in your Catalog; omits any remote cores.

**Show remote cores that are not in my vault** - Displays remote cores that have not been added to your vault in your Catalog.

## CDB File Organization Dialog Box

The CDB File Organization dialog box manages conflict resolution between the blocks in your design.

It is important to preserve the order of your CDB files if they are interdependent. Use the CDB File Organization dialog box to set the compile order for your CDB files (as shown in the figure below). CDB file organization is a pre-module setting; modifying the CDB order will apply to all ADBs of a given module.

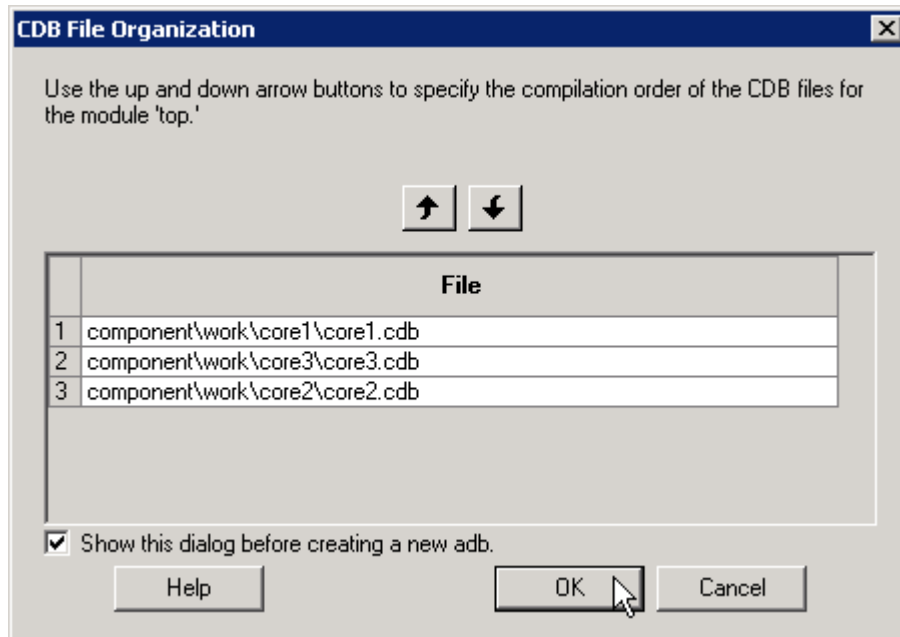

Figure 120 · CDB File Organization Dialog Box

Use the up and down arrows to specify the order, or drag the files into order. Select the checkbox to show the dialog before you create a new ADB file.

## Change All Links Dialog Box

The Change All Links dialog box enables you to update/change all the links for the files in your project at once.

This dialog box is useful when you are linking to shared network folders that may be renamed by other users, or to folders on your local machine that have been renamed.

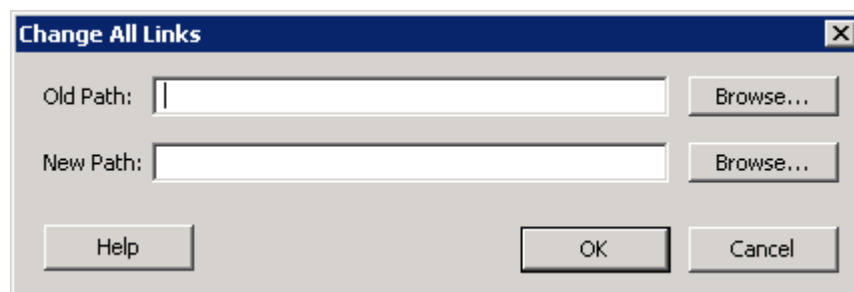

Figure 121 · Change All Links Dialog Box

**Old Path** - Location of your old project files. Click the browse button to navigate to the location.

**New Path** - Location of your new project files. Click the browse button to navigate to the location.

## Configure Flow Dialog Box

When you click Configure Project Flow in the Project Flow window you can choose to configure the flow for your modules.

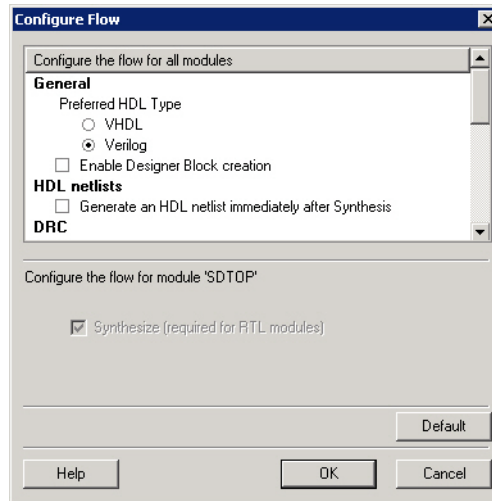

Figure 122 · Configure Flow Dialog Box

## Configure the flow for all modules

### General

**Preferred HDL Type** - Set your preferred HDL type to VHDL or Verilog.

### HDL Netlists

The HDL project-level options enable you to specify whether or not you want to generate your HDL netlists after synthesis.

- **Generate an HDL netlist immediately after synthesis** - Select this option if you run post-synthesis simulation. If you do not run post-synthesis simulation, de-select this option to start Designer more quickly.

### DRC

**Run DRC immediately after synthesis** - This option evaluates the netlist generated by Synplify to ensure it does not have any connection problems.

### ModelSim

**Update modelsim.ini automatically** - May be useful if the Project Manager does not create a valid modelsim.ini file. Click the checkbox to enable.

### ViewDraw

**Generate HDL netlist after a Save&Check in ViewDraw** - Useful if you wish to eliminate the manual step of generating your HDL netlist after a Save&Check.

**Update viewdraw.ini automatically** - May be useful if the Project Manager does not create a valid viewdraw.ini file. Click the checkbox to enable.

**File Detection - Detect new files on disk automatically** enables the Project Manager to see new files when you add them to your project. If you deselect this option, you must add the new files manually.

**Core generation - Generate resource report** creates and saves the core resource report after you generate a core.

**FlashPro options** - Input programming file for FlashPro sets your input programming file. PDB files enable you to configure the security settings in FlashROM and Flash Memory from FlashPro.

## Configure the flow for module <module\_name>

You can also choose to enable or disable synthesis if you are using a structural implementation. Synthesis is required for RTL modules and cannot be disabled.

To view this dialog box, click **Configure Flow** in the Project Manager Project Flow window.

## Convert Project Dialog Box

The Convert Project dialog box enables you to create a backup file of your project before you convert the project data to use with your current version of Libero IDE (as shown in the figure below).

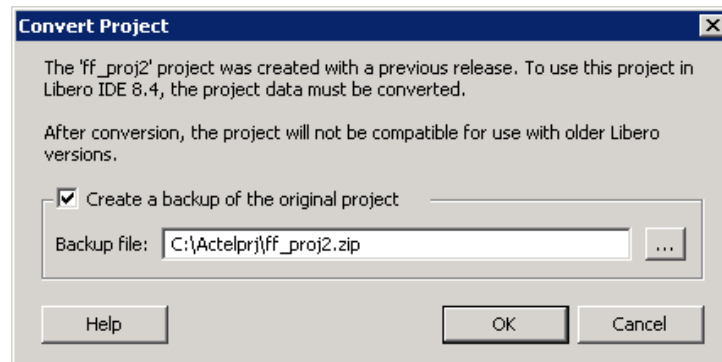

Figure 123 · Convert Project Dialog Box

**Create a backup of the original project** - Creates a backup of your project and saves it as a zip file in the directory you specify. Click the browse button to set the location of the backup file.

## Export Profiles Dialog Box

Use the Export Profiles dialog box to create an INI file and save your tool profiles.

After you create an INI file, you can import it into other Libero IDE projects.

Specify a filename and click **Save**, or click **Cancel** to return to the Project Manager.

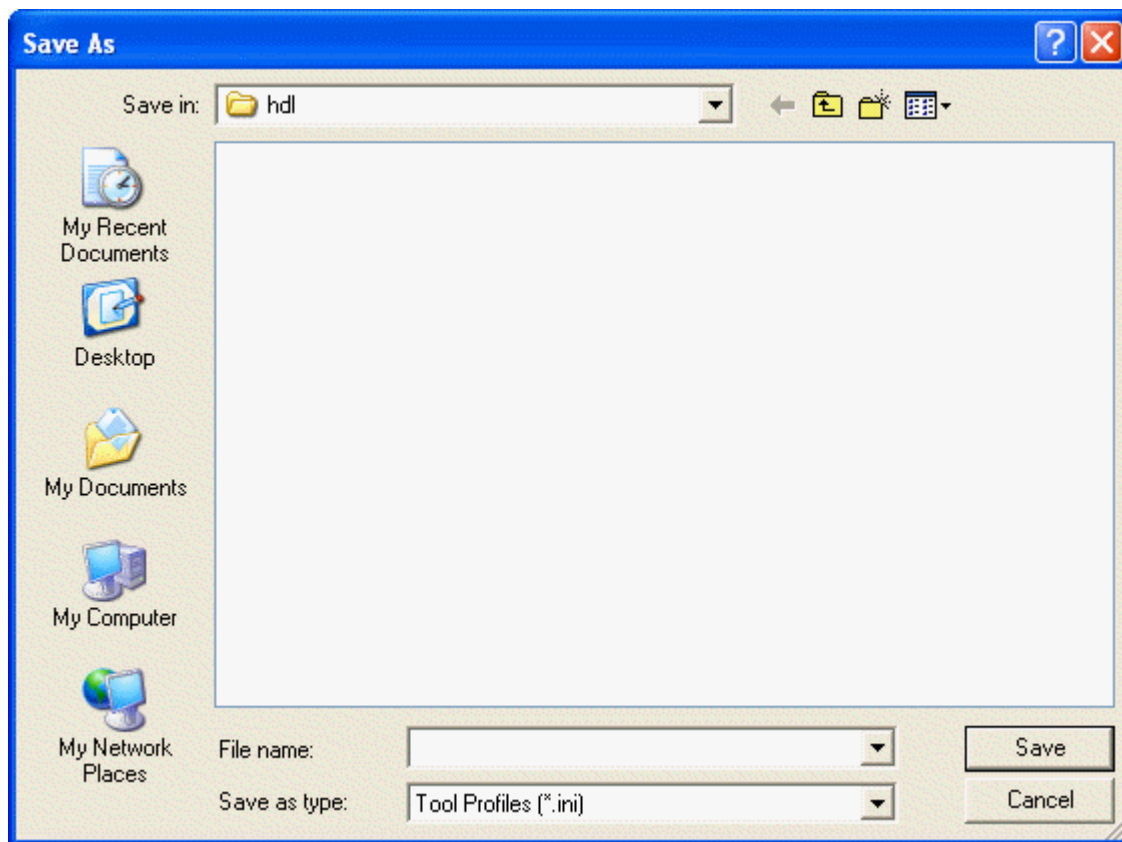
**Save in**

Specifies the director in which to save your exported tool profile. Browse to select a different directory.

**File name**

Type the file name for your exported tool profile.

**Save as type**

Specifies the file type displayed in the dialog box. Only INI files are supported for tool profiles.

To access this dialog: from the **File** menu, choose **Export > Profiles**.

## Import Files Dialog Box (Project Manager)

Use the Import Files dialog box to add new files to your project in the Libero IDE Project Manager.

You can import schematics, VHDL or Verilog source files, stimulus files, SDC, PDC, VCD, and SAIF files, cores, and even tool profiles (from other Libero IDE projects).

Browse to and select the file you wish to add and click **Import**, or click **Cancel** to return to the Project Manager.

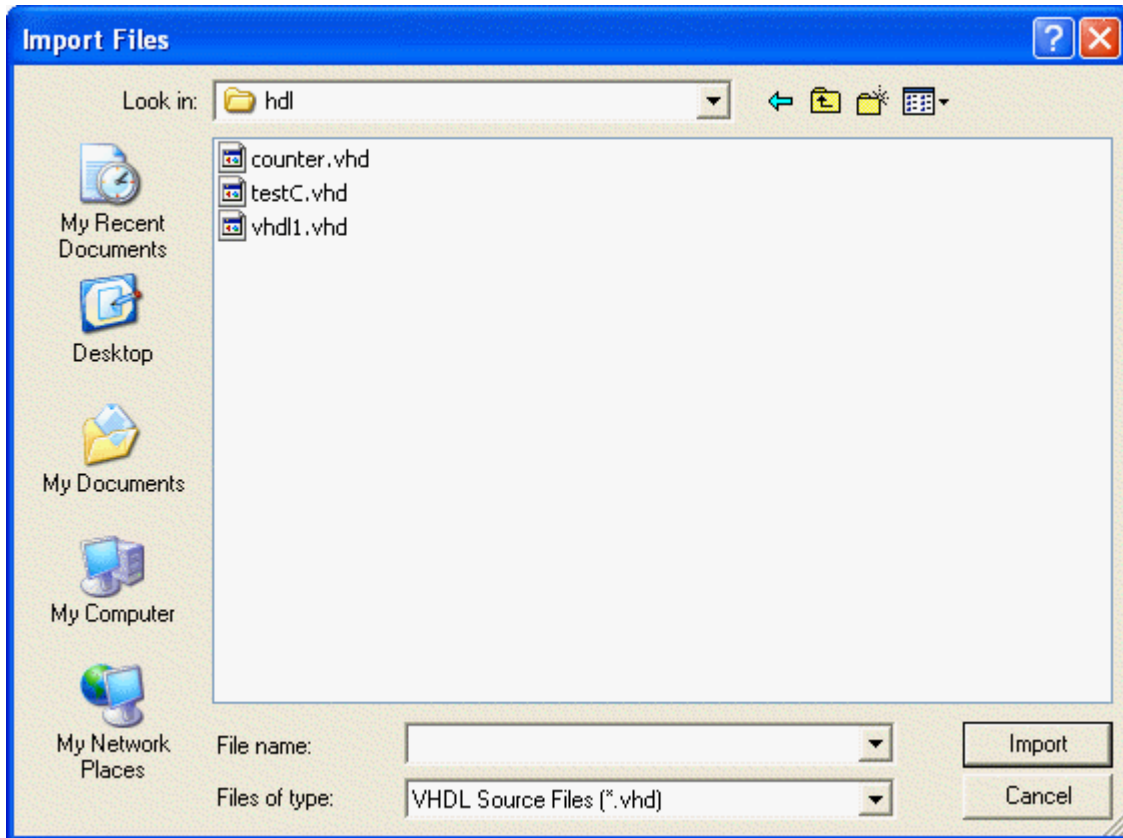
**Look in**

Specifies your current directory. Browse to find your file if it is not listed here. If you are in the correct directory and your file is not listed here, select the **File of type** extension to match it.

**File name**

Type the file name, or browse to its location and select it.

**File of type**

Specify the file type displayed in the dialog box.

To access this dialog: from the **File** menu, choose **Import Files**.

## New Project Wizard: Add Files

This step of the New Project Wizard enables you to copy files to your new project directory.

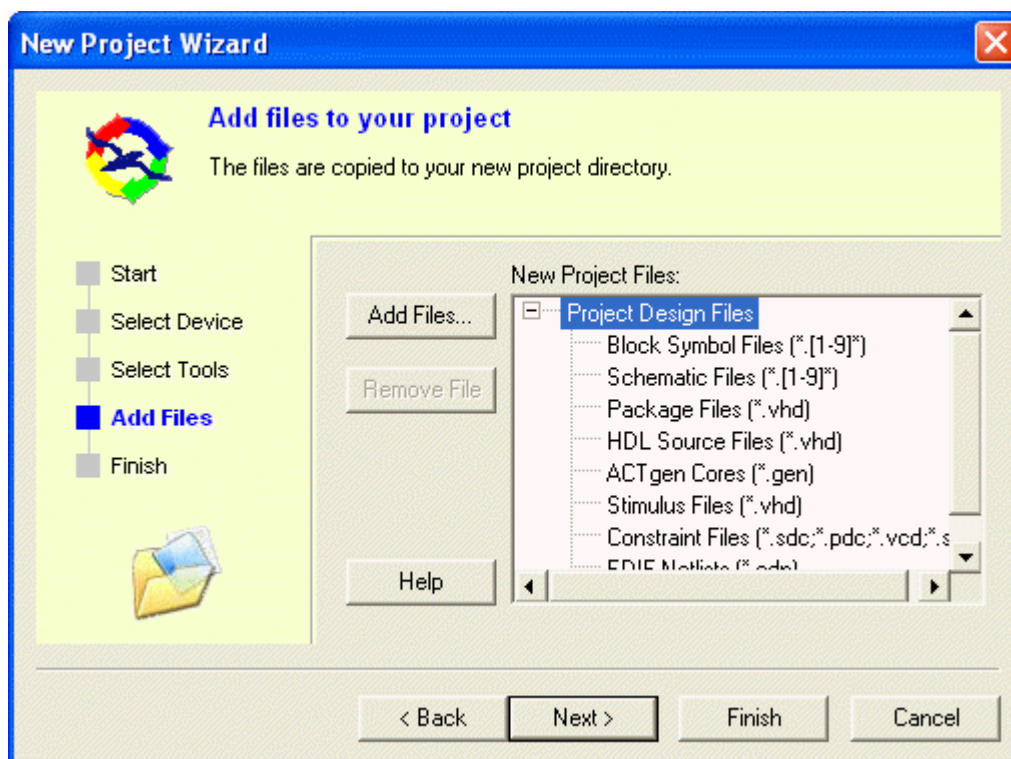

### Add Files

Select a file type in the New Project Files list and click Add Files to add a file to your new project.

### Remove File

Select a file you have added in the New Project Files list and click Remove Files to delete it.

### To add a file:

1. Select the file type in New Project Files.
2. Click **AddFile**.
3. Select the file to add and click **Add**. The file appears in New Project Files.
4. Continue adding files for your new project. When done, click **Next**. Drag files to re-order them in the New Project Files hierarchy.
5. Click **Next**.

To access this dialog, from the **Project** menu, choose **NewProject** and follow the instructions in the New Project Wizard.

## New Project Wizard: Completing

This dialog box displays a summary of all the elements of your new project. Review the list and click **Back** to return to the previous screens and change your project options. Click **Finish** to create the project as shown.



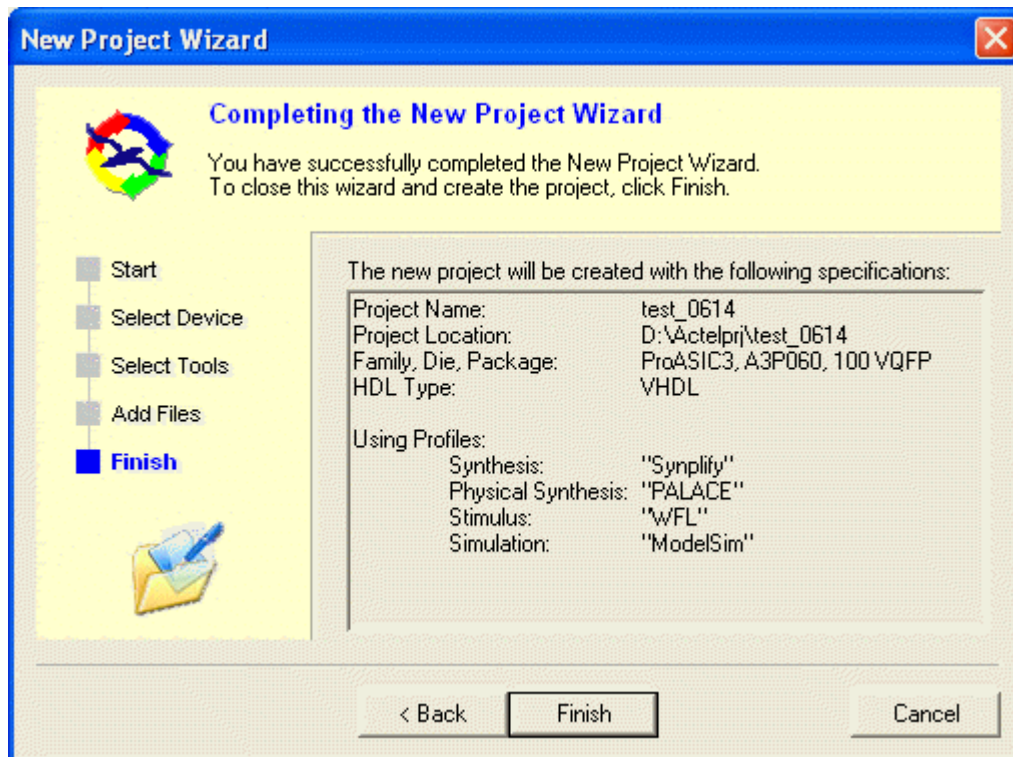

To access this dialog, from the **Project** menu, choose **NewProject** and follow the instructions in the wizard.

## New Project Wizard: Start

Use the New Project Wizard to create new projects in the Project Manager. The wizard creates all the [directories](#) for your project in one top-level project directory.

Enter information about your new project and click Next.

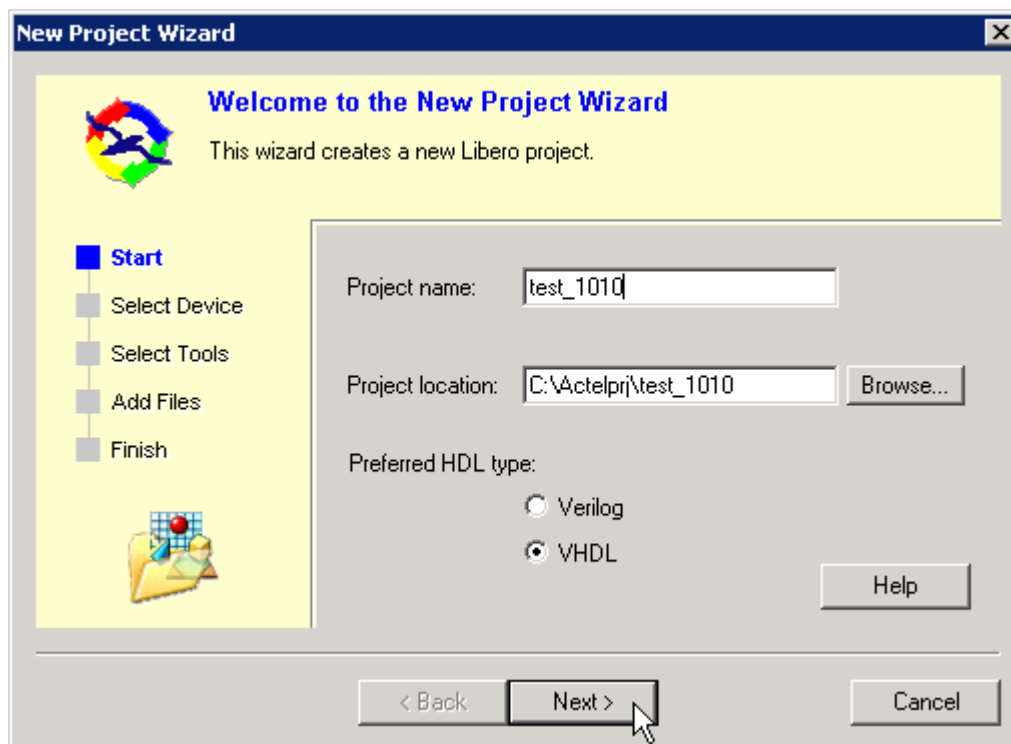

Figure 124 · New Project Wizard Dialog Box - Start

**Project Name**

Type the project name.

**Project Location**

Accept the default location or browse to the new location where you can save and store your project. All files for your project are saved in this directory.

**Preferred HDL type**

Select Verilog or VHDL. Libero IDE supports [mixed-HDL](#) design flows.

To access this dialog, from the **Project** menu, choose **New Project**.

## New Project Wizard: Select Device

Select the family device, die, and package you intend to use for your project. You may select a package only after you have selected a family and die.

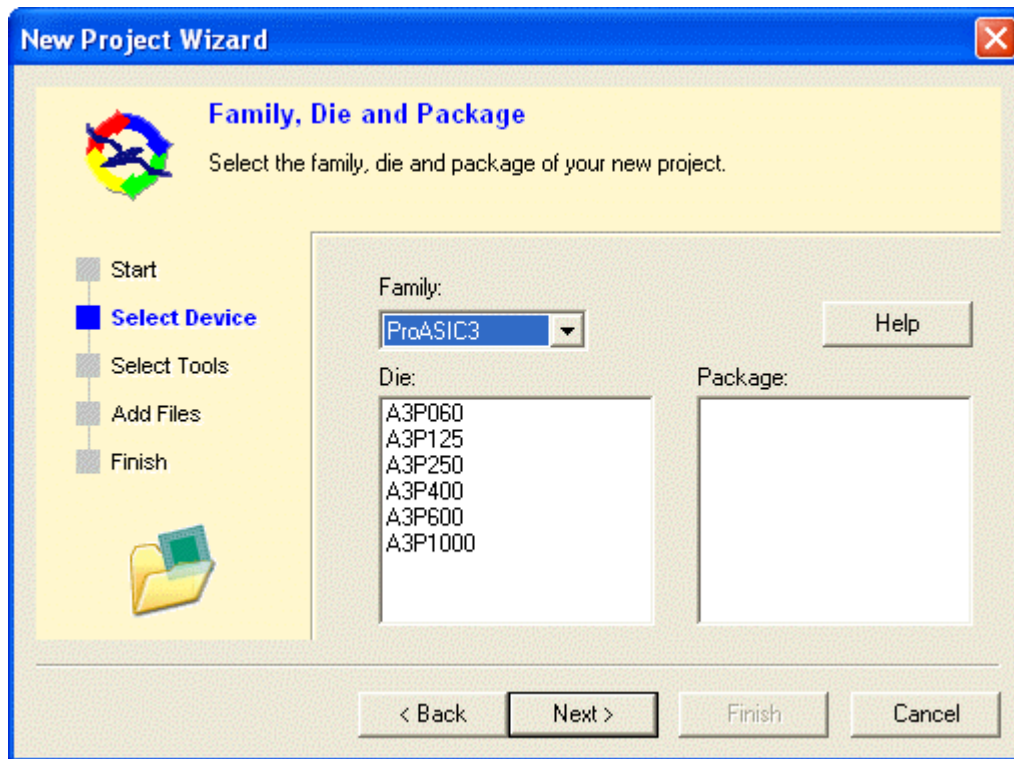
**Family**

Select your device family from the drop-down menu.

**Die**

Select the die for your project.

**Package**

Select the package for your project. The package list varies according to the die you select.

Click Next to add files or Finish to open the new project without importing files.

To access this dialog, from the **Project** menu, choose **New Project** and follow the instructions in the New Project Wizard.

## New Project Wizard: Select Integrated Tools

Select the tools you want integrated with this project. Click Add and select the tool type, or select a tool and click Edit to specify the tool location. The example shows the tools available in the default Libero IDE installation. This dialog box sets your project profile information.

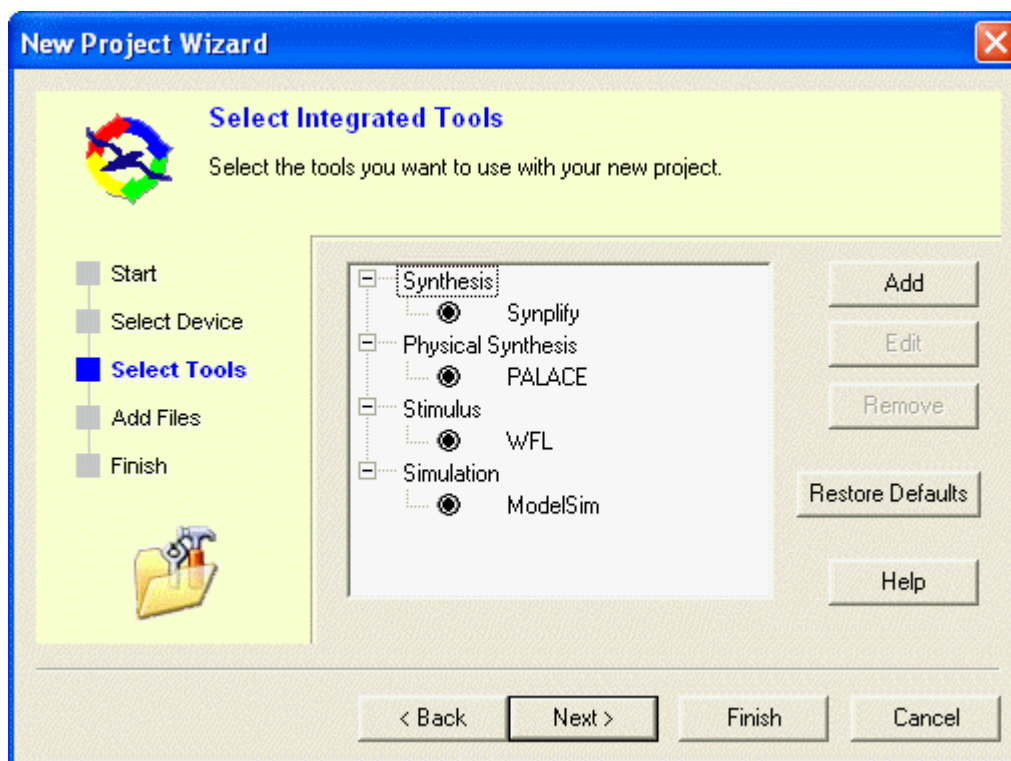
**Add**

Click and select a tool type, and then enter the tool profile information.

**Edit**

Opens the tool profile manager for the tool you selected.

**Remove**

Select a tool and click Remove to remove a tool from the project.

**Restore Defaults**

Restores the default tools and locations.

Click Next to add files or Finish to open the new project without importing files.

To access this dialog, from the **Project** menu, click **New Project** and follow the instructions in the New Project Wizard.

## Open Project Dialog Box

Use the Open Project dialog box to navigate to and open existing projects in the Project Manager. Browse to your project and click **Open**, or click **Cancel** to return to the Project Manager.

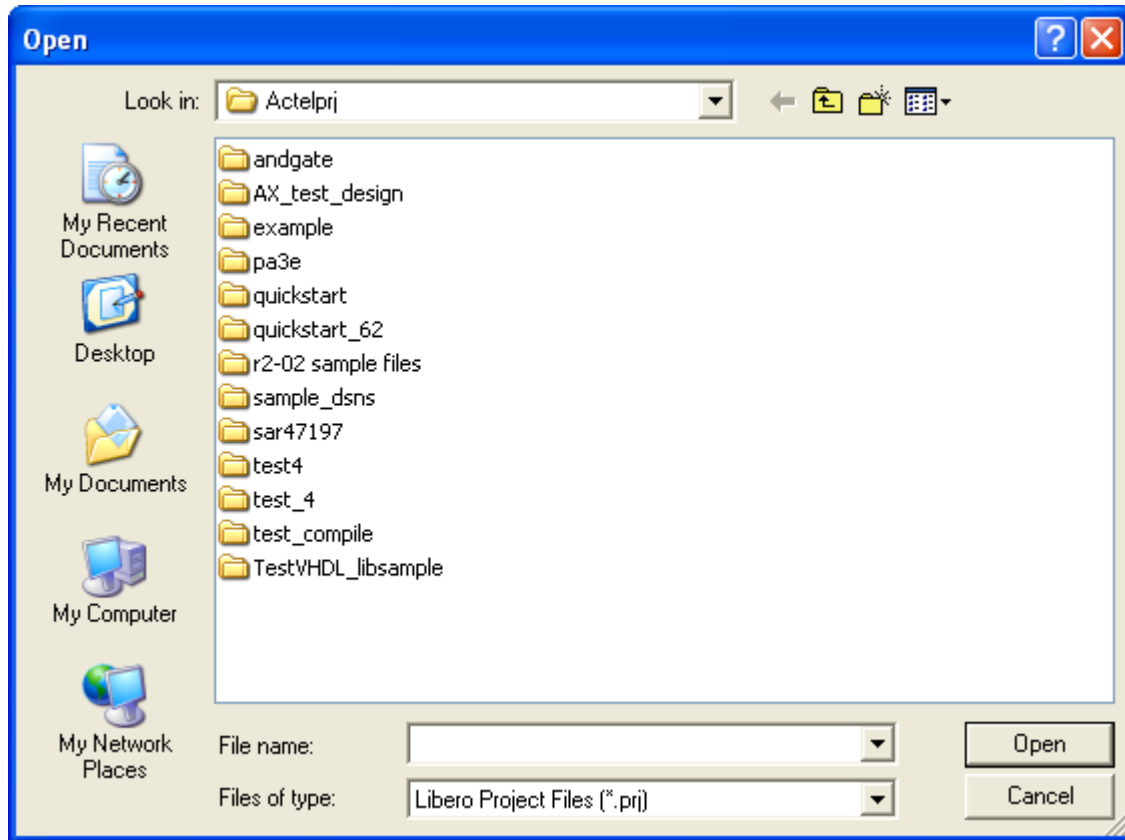
**Look in**

Specifies the directory that contains your project.

**File name**

Type the file name, or browse to its location and select it.

**File of type**

Specify the file type displayed in the dialog box.

To access this dialog: from the **Project** menu, select **Open Project**.

## Organize Constraints for Synthesis Dialog Box

The Organize Constraints for Synthesis dialog box enables you to specify the order of your constraint files in your synthesis tool. Synthesis supports only SDC files.

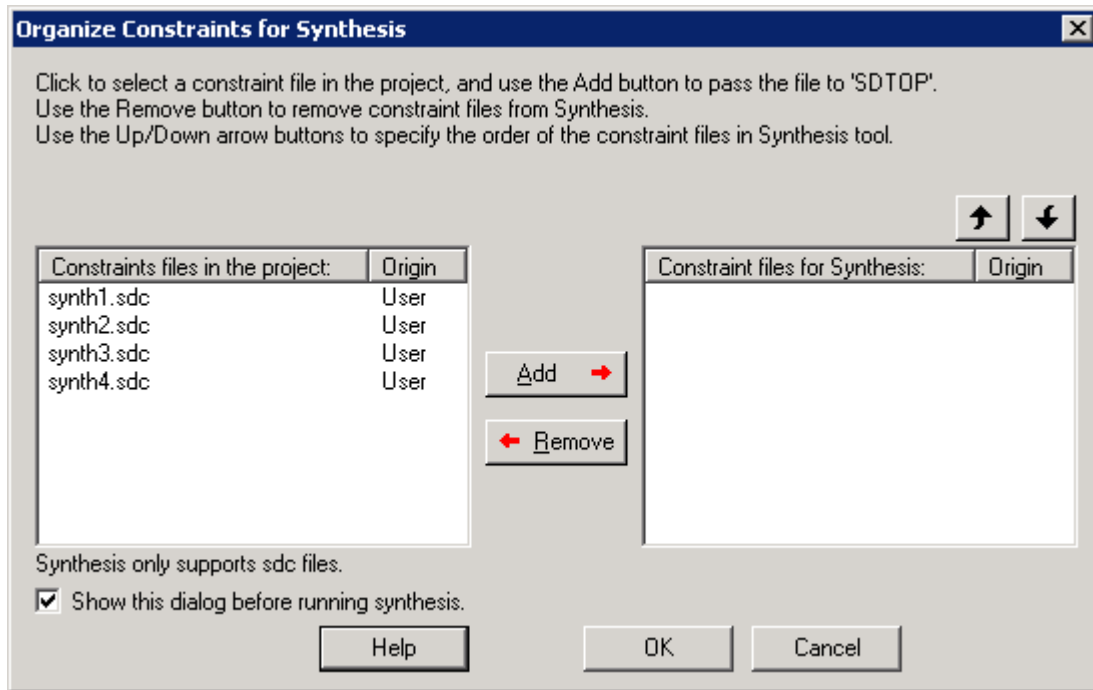

Figure 125 · Organize Constraints for Synthesis Dialog Box

**Constraints files in the project / Origin**

Lists all the synthesis constraint files in your current Libero IDE project and the origin of the file.

**Constraint files for Synthesis / Origin**

Lists the constraint files you have added for synthesis and their origin. The synthesis order proceeds from the top of the list to the bottom. Use the Up and Down arrows to change the order of the files.

**Add**

Adds files to the Constraint files for Synthesis list in your project.

**Remove**

Removes files from the Constraint files for Synthesis list in your project.

**Up and Down Arrows**

Use these buttons to order the stimulus files.

De-select the **Show this dialog before running synthesis** checkbox if you do not wish to organize your constraints each time you run synthesis.

## Organize Stimulus Dialog Box

Use the Organize Stimulus dialog box (below) to manage the stimulus files in your project.

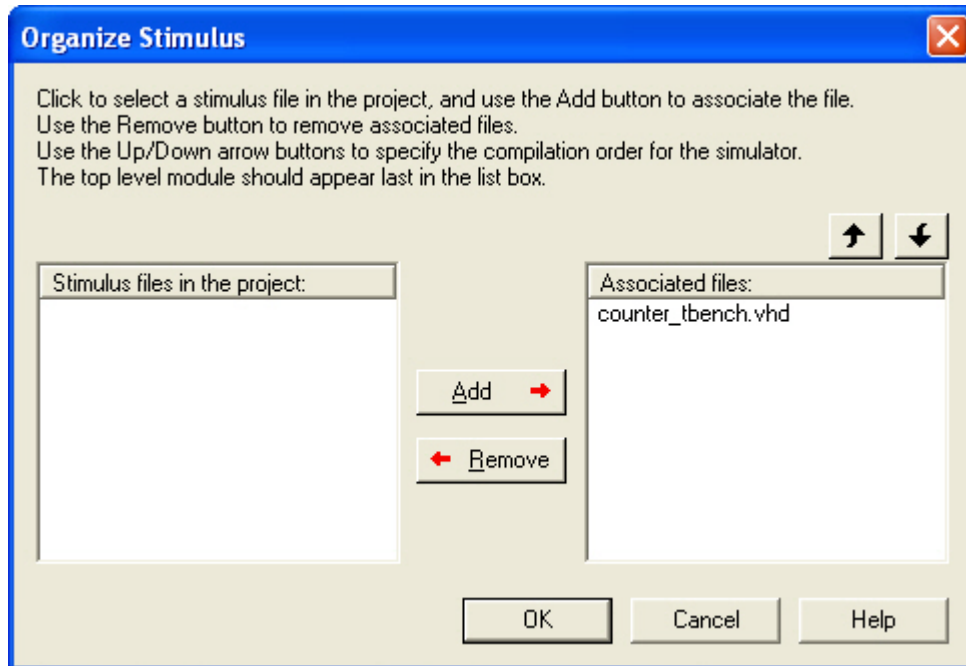

Figure 126 · Organize Stimulus Files Dialog Box

**Stimulus files in the project**

Lists all the stimulus files in your current Libero IDE project. In most cases you will only have one testbench associated with your block. However, if you want simultaneous association of multiple testbench files for one simulation session, as in the case of PCI cores, add multiple files to the *Associated Files* list box.

**Associated files**

Lists all the files associated with your project.

**Add**

Adds files to the Associated files list in your project.

**Remove**

Removes files from the Associated files list in your project.

**Up and Down Arrows**

Use these buttons to order the stimulus files. The top-level entity should be at the bottom of the list.

## Page Setup Dialog Box

Use this dialog box to format your page header and footer. The default displays your project file name in the header and the page number of the total number pages (such as "1 of 4") in the footer.

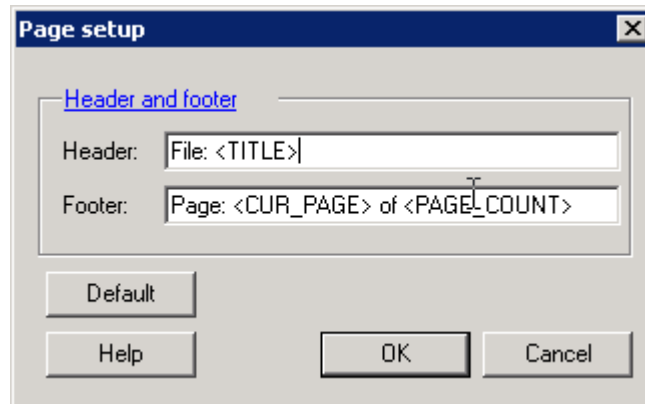

Figure 127 · Page Setup Dialog Box

You can add additional information about your project, such as a project description, the names of team members, or the date you started. To do so, type the information into the Header (or Footer) field.

The Default button resets the fields to their original settings.

## Profiles Dialog Box

In the Libero IDE project, each user can activate predefined tool profiles (created during Libero IDE's installation) or custom user tool profiles. You can create new custom user tool profiles if you want to add tools, try a different tool, change to an older or newer version, etc.

For example, if you have an existing Synplify installation and want to use it instead of the Libero IDE default, you can create a custom tool profile and assign it to your custom installation. Your custom Synplify installation is attached to your custom user profile and appears in all your Libero IDE projects.

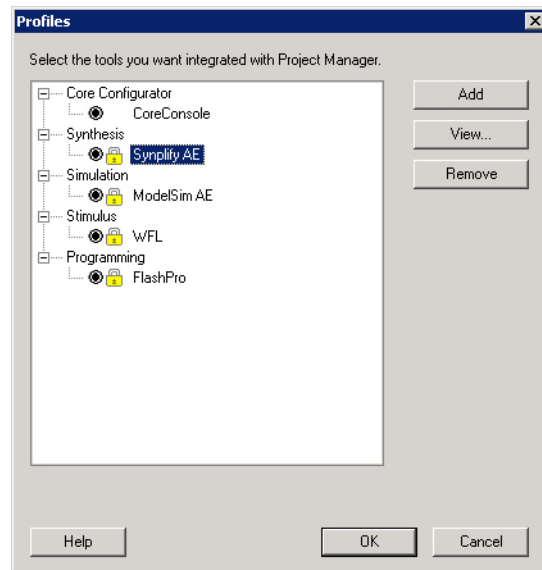

Figure 128 · Project Profiles Dialog Box



You can export and import your custom profiles; this is useful if you wish to share your profiles with someone else. To export, from the File menu choose Export Profiles. To import, from the File menu, choose Import Files and select Tool Profiles as the file type.

Your Profiles dialog box includes predefined system profiles for the Libero IDE tools. Default predefined profiles are locked and cannot be edited or deleted.

A red question mark next to a profile means that the location or version of the tool has changed. If your user profile has a red question mark you can click Edit to [specify the location of the tool](#).

If your system profile shows a red question mark you may have opted not to install that tool during the Libero IDE setup/install. If you are using a different version of the tool you can create a custom profile that points to the correct tool location but you cannot update the default system profile.

### Add

Click **Add** and select which type of tool (synthesis, stimulus, or simulation). Fill out the tool profile and click **OK**.

### Edit

After selecting the tool, click to **Edit** to select another tool, change the tool name, or change the tool location.

### Remove

After selecting a tool, click **Remove**.

To access this dialog, from the **Project** menu, choose **Profile**.

### Clone a Profile

Right-click a profile in the Profiles dialog box and choose **Clone**.

Cloning a profile opens the [Add Profile](#) dialog box and populates the fields with the values from the profile you cloned. This is useful if you wish to create a new tool profile based on an existing tool profile and do not wish to re-type the information.

### See Also

[Synplify AE](#)

[WaveFormer Pro](#)

[ModelSim AE](#)

## Save Project As Dialog Box

The Save Project As dialog box enables you to save your entire project (Designer views, tool profiles, etc.) with a new name and location. save

Enter the name and location for your modified project and click OK to continue.

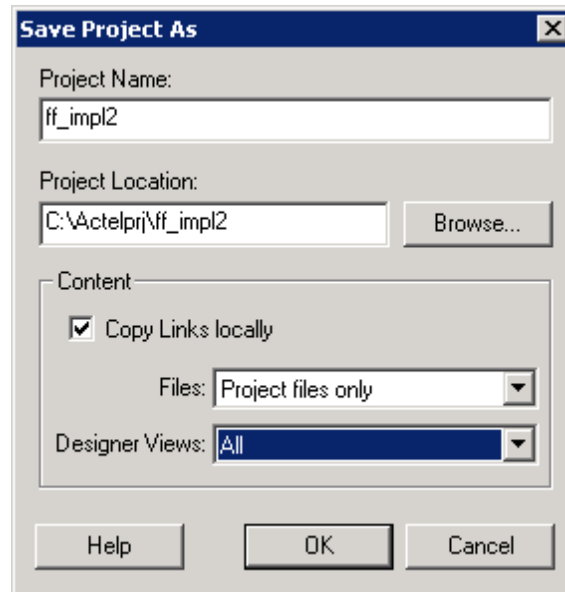

Figure 129 · Save Project As Dialog Box

**Project Name**

Type the project name for your modified project.

**Project Location**

Accept the default location or **Browse** to the new location where you can save and store your project. All files for your project are saved in this directory.

**Content**

**Copy Links locally** - Select this checkbox to copy the links from your current project into your new project. If you do not select this checkbox, the links will not be copied and you must add them manually.

**Files**

- Select All - Includes all your project and source files in your new project.
- Project files only - Copies only your project files into your new project (only the files in the Files tab of the Design Explorer).
- Source files only - Copies only your source files into your new project; for example, simulation files are not preserved.
- None - Saves a new empty project.

**Designer Views** - Select All, Current view, or None to copy your views into your new project.

To access this dialog, from the **Project** menu, choose **Save Project As**.

## Script Export Options Dialog Box

If you export a Tcl script in the Project Manager, the Script Export Options dialog box appears.

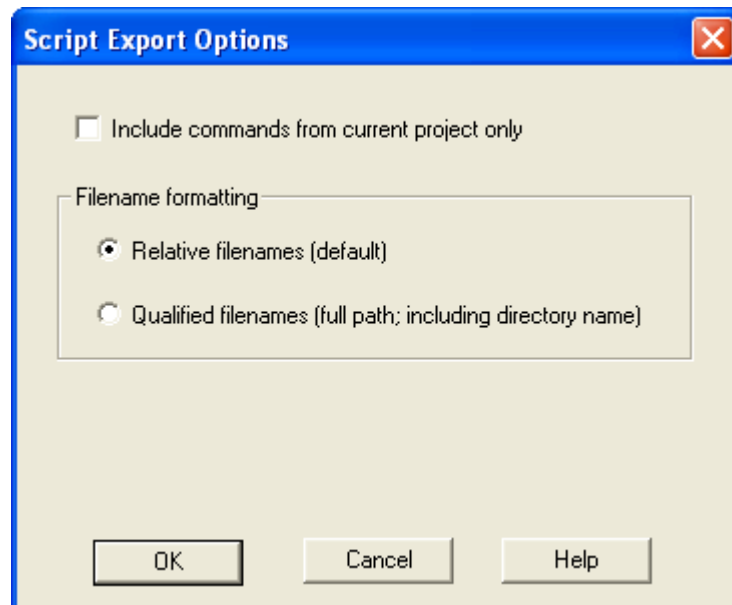

Figure 130 · Script Export Options Dialog Box





**Include commands from current project only** - Select this option if you want to include all the commands from your current project.

**Filename Formatting** - Choose **Relative filenames** if you do not intend to move the Tcl script from the saved location, or **Qualified filenames** if you plan to move the Tcl script on your machine.



## Project Manager Project Menu

Command	Sub-menu	Icon	Function
New Project			Starts the New Project Wizard
Open Project			Opens the Open Project dialog box
Close Project			Closes the current active project; the Project Manager remains open
Save Project			Saves the current project
Save Project As			Saves the current project in a new directory; prompts you to enter a new project name
Detect New			Detects new files and adds them to the Project

Command	Sub-menu	Icon	Function
Files			Manager (if found).
VHDL Library >	Add		Add a VHDL library in your project
	Remove		Remove a VHDL library in your project
	Rename		Rename a VHDL library in your project
Settings			Opens the Project Settings dialog box; enables you to manage device, simulation, and programming options for your project
Profile			Opens the Project Profile dialog box; enables you to specify locations for your third-party synthesis, stimulus, and simulation tools. Libero IDE includes tools for synthesis, stimulus, and simulation.
Configure Project Flow			Opens the Configure Flow dialog box, sets options on your HDL netlists, DRC checker, ViewDraw, and a resource report when you generate a core.
File Organization >	Source Files for Synthesis		Opens the Organize Source Files for Synthesis dialog box
	Source Files for Simulation		Opens the Organize Source Files for Simulation dialog box
	Designer Constraint Files		Opens the Organize Constraints for Designer dialog box; enables you to organize your Designer constraint files in the Project Manager
	Designer CDB Files		Opens the CDB File Organization dialog box; the CDB File Organization dialog box manages conflict resolution (if any) between the blocks in your design
	Stimulus		Opens the Organize Stimulus dialog box; enables you to organize your stimulus files in the Project Manager
Designer Views >	Select		Choose your Designer View from the drop down menu. Note that views are listed in they order they

Command	Sub-menu	Icon	Function
			were created
	Previous		Switches to the previous view
	Next		Switches to the next view
	Add		Opens the Add Designer View dialog box; enables you to specify the name of your latest view
	Remove		Opens Remove Designer View dialog box; enables you to delete all related Designer View files from your disk
	Rename		Opens Rename Designer View dialog box; select the Designer View you want to rename and enter the new name
Execute Script			Opens Execute Script dialog box; enables you to run Tcl script from the Project Manager
Preferences			Opens the Preferences dialog box
Recent Projects			Opens list of recent Libero IDE projects.
Exit			Closes Project Manager







## Project Manager File Menu





Command	Icon	Shortcut	Sub-menu	Function
New		Ctrl + N		Opens the Project Manager New file dialog box and prompts you to enter a name and specify a file type
Open		Ctrl + O		Opens the Project Manager Open dialog box; enables you to select a file to open

Command	Icon	Shortcut	Sub-menu	Function
Close				Closes the current file; the Project Manager remains open
Save		Ctrl + S		Saves the current file
Save As				Saves the current file as a different type (such as a TXT file)
Import Files				Opens the Import Files dialog box; enables you to import project files into the Project Manager
Create Link				Opens the Create Link dialog box; browse to select the file you wish to link. Linked files are added to the Design Explorer in the Modules defined in multiple files list.
Change All Links				Opens the Change All Links dialog box; enables you to update/change all the links for the files in your project at once.
Unlink All: Copy Files Locally				Copies all linked files to your local project.
Export >			Profiles	Opens the Project Manager Export dialog box, and defaults to save the exported file with the profile (INI) extension.
			Script Files	Opens the Project Manager Export dialog box, and defaults to save the exported file with the Tcl (TCL) extension.
			Template	Opens the Project Manager Export dialog box, and defaults to save the exported file as a template with a VHD or VLG extension.

Command	Icon	Shortcut	Sub-menu	Function
Print				Displays the Print dialog box (if available); allows you to print whatever element of the project you are working on
Print Preview				Previews your selection before you print (if available)
Page Setup				Opens the Page Setup dialog box; enables you to format your page header and footer

## Project Manager Edit Menu

Command	Sub-menu	Icon	Shortcut	Function
Undo			CTRL + Z	Reverses your last action
Redo			CTRL + Y	Reverses the action of your last Undo command
Cut			CTRL + X	Removes the selection from your design
Copy			CTRL + C	Copies the selection to the Clipboard
Paste			CTRL + V	Pastes the selection from the Clipboard
Select All			CTRL + A	Selects all the content in your current file (such as in a VHDL file open in the VHDL editor)
Find and Replace >	Find		CTRL + F	Displays the Find dialog box, which you use to locate instances, nets, ports, and

Command	Sub-menu	Icon	Shortcut	Function
				regions
	Find Next		F3	Finds the next occurrence of the text in the Find field
	Replace		CTRL + H	Displays the Replace dialog box; enables you to search and replace content in your files (files must be open and selected to use this feature)
	Find in Files			Opens the Find in Files dialog box; enables you to search for text in files or directories that you specify
	Find Module / Component			Opens the Find Module dialog box; searches the Libero IDE project for specific entity (module) names
Comment Out			CTRL + M	Inserts comment characters in the selected line (or lines) of your text editor
Uncomment Out			CTRL + K	Removes comment characters from the selected line (or lines) of your text editor
Filter			CTRL + R	Refreshes the display

## Project Manager View Menu

Command	Sub-menu	Shortcut	Function
Toolbars >	Status Bar		Shows/hides status bar in Project Manager
	Standard		Shows/hides standard toolbar in Project Manager













Command	Sub-menu	Shortcut	Function
	Designer Views		Shows/hides Designer views toolbar in Project Manager
	Canvas		Available only when using SmartDesign; shows/hides the Canvas toolbar in Project Manager
	Top Symbol		Available only when using SmartDesign; shows/hides the top symbol toolbar in Project Manager
	Rotate		Available only when using SmartDesign; shows/hides the Rotate toolbar in Project Manager
	Align		Available only when using SmartDesign; shows/hides the Align toolbar in Project Manager
	Shape		Available only when using SmartDesign; shows/hides the Shape toolbar in Project Manager
	Zoom		Available only when using SmartDesign; shows/hides Zoom toolbar in Project Manager
	Schematic		Available only when using SmartDesign; shows/hides Schematic toolbar in Project Manager
	SmartDesign Tools		Available only when using SmartDesign; shows/hides SmartDesign Tools toolbar in Project Manager
	Design Explorer		Shows/hides Design Explorer window in Project Manager
	Catalog		Shows/hides Catalog window in Project

Command	Sub-menu	Shortcut	Function
			Manager
	Information Window		Shows/hides Information Window in Project Manager
	Find Window		Shows/hides Find window in Project Manager
	Log Window		Shows/hides Log window in Project Manager
	Configure Information Window		Enables you to show/hide elements in the Information Window, such as lists of new features, or properties of your current project.
Project Flow Window			Shows/hides the Project Flow window in the Project Manager
Bring Project Flow Window to the front		F2	Moves Project Flow window to the front of display; useful if you have several windows open simultaneously.
Refresh Design Hierarchy		CTRL + R	Updates the Hierarchy tab in the Design Explorer window. Useful if you add files to the project and Project Manager does not show them in the Hierarchy.
Reset Window Layout			Returns Project Manager window layout to default.
Maximize Work Area		CTRL+W	Hides the Catalog, Log Window, and Design Explorer windows (if open) and expands the selected tab in the Project Flow or SmartDesign work area.
Zoom >	Zoom In	CTRL ++	Zooms into the view in the Project Manager (if enabled)

Command	Sub-menu	Shortcut	Function
	Zoom Out	CTRL + -	Zooms out of the view in the Project Manager (if enabled)
	Zoom Region	CTRL + W	Zooms into a region of the view in the Project Manager (if enabled); click and drag to select a region.
	Zoom Fit	CTRL + 0	Fits the view into the Project Manager (if enabled)
	Pan		Scrolls the view in the Project Manager (if enabled)







## Project Manager Tools Menu

Command	Sub-menu	Icon	Function
HDL Editor			Opens the New file dialog box and defaults to VHDL entity. Enter a filename and click OK to open the VHDL editor.
SmartDesign			Opens the New file dialog box and defaults to SmartDesign component. Enter a filename and click OK to open SmartDesign.
CoreConsole			Opens the New file dialog box and defaults to CoreConsole component. Enter a filename and click OK to open CoreConsole.
ViewDraw			Opens the New file dialog box and defaults to Schematic. Enter a filename and click OK to open ViewDraw.
ViewDraw >	Generate		Creates a new EDIF file from the

Command	Sub-menu	Icon	Function
Tools	EDIF		schematic
	Generate HDL		Creates a new HDL file from the schematic
Synplify Synthesis			Starts Synplify
WaveFormer Stimulus			Starts WaveFormer and creates a stimulus file named after your project
ModelSim Simulation			Starts ModelSim AE and opens any existing simulation files in your project
Designer Place-and-Route			Starts Designer; enables you to compile, layout, and analyze your design.
Silicon Sculptor			Starts the Silicon Sculptor programming tool
FlashPro			Starts the FlashPro programming tool
Silicon Explorer			Starts the Silicon Explorer debug tool (if available)
Identify Debugger			Opens the Identify Debugger (from Synplify)

## Reference

### SmartDesign Menu

Command	Icon	Function
Show Canvas View		Displays the Canvas
Show Grid View		Displays the Grid
Show Schematic View		Displays the Schematic Viewer
Show Memory Map / Data Sheet		Displays the datasheet for the design
Check Design Rules		Runs the Design Rules Check
Generate Design		Generates your SmartDesign component
Auto Connect		Auto-connects instances
Add Port		Adds a port to the top of the SmartDesign component

### Project Manager Window Menu

The Project Manager Window menu controls the Design Flow, HDL Editor, and SmartDesign windows that open in the Project Manager.

Command	Function
Close	Closes the active window (HDL Editor or Project Flow window)
Close All	Closes all the open windows
Cascade	Cascades all open windows in the Project Manager

Command	Function
Tile Vertically	Tiles all open windows in the Project Manager vertically
Tile Horizontally	Tiles all open windows in the Project Manager horizontally
Project Flow	Shows project flow window in Project Manager
<*.vhd filename>	Shows VHD file, if open, in Project Manager

## Project Manager Help Menu

The Help menu enables you to access the Libero IDE online help, reference manuals, check for updates, and view your license and version information.

Command	Icon	Function
Help Topics		Opens the Libero Project Manager online help
Reference Manuals		Opens the list of manuals (PDF files) available for Libero Project Manager, including links to library guides, PDF versions of the online help, and information about third party (OEM) tool guides.
Actel Technical Support		Displays the Actel customer support web page in your default browser
Actel Web Site		Displays the main Actel page in your default browser
Check for Software Updates		Checks for updates to the Libero Project Manager software
License Details		Displays detailed license information for your version of Libero IDE Project Manager
About Libero Project Manager		Displays version and release numbers for Libero IDE Project Manager

## Dialog Boxes

### EDIF Import Options

When importing an EDIF netlist, you must specify your EDIF flavor. Your choices are

- GENERIC - For any non-Viewlogic and Mentor Graphics netlists
- VIEWLOGIC - For Viewlogic EDIF netlists
- MGC - For Mentor Graphics EDIF netlists

Select the flavor that you wish to use with your design and click **OK**.

Select the **Do not show this dialog box during import** checkbox if you do not want to be asked about this option again.

### Execute script dialog box

You can use the Execute Script dialog box to run [Tcl scripts](#) from within Designer. You do not need to have a design open in order to run a script.

Specify a script file, enter Arguments (if necessary), and click Run to execute.

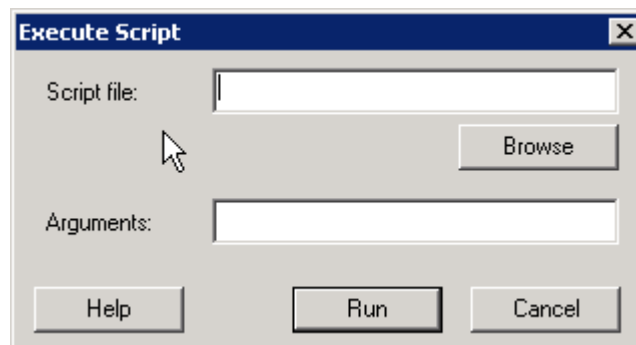

Figure 131 · Execute Script Dialog Box

#### Script file

Specify a script file. Browse to Select a script file with a valid extension (\*.tcl or \*.dsf).

#### Arguments

Input your arguments for your script file (if necessary).

### Export Script / Log Files dialog box

The Export Script Files and Export Log Files dialog box both open from the File > Export menu in Designer. Select **File > Export > Script Files** or **Export > Log Files** to open the dialog box. The only difference is the files that display in the dialog boxes: Export Script Files displays only \*.tcl files, and Export Log Files displays only \*.log files.

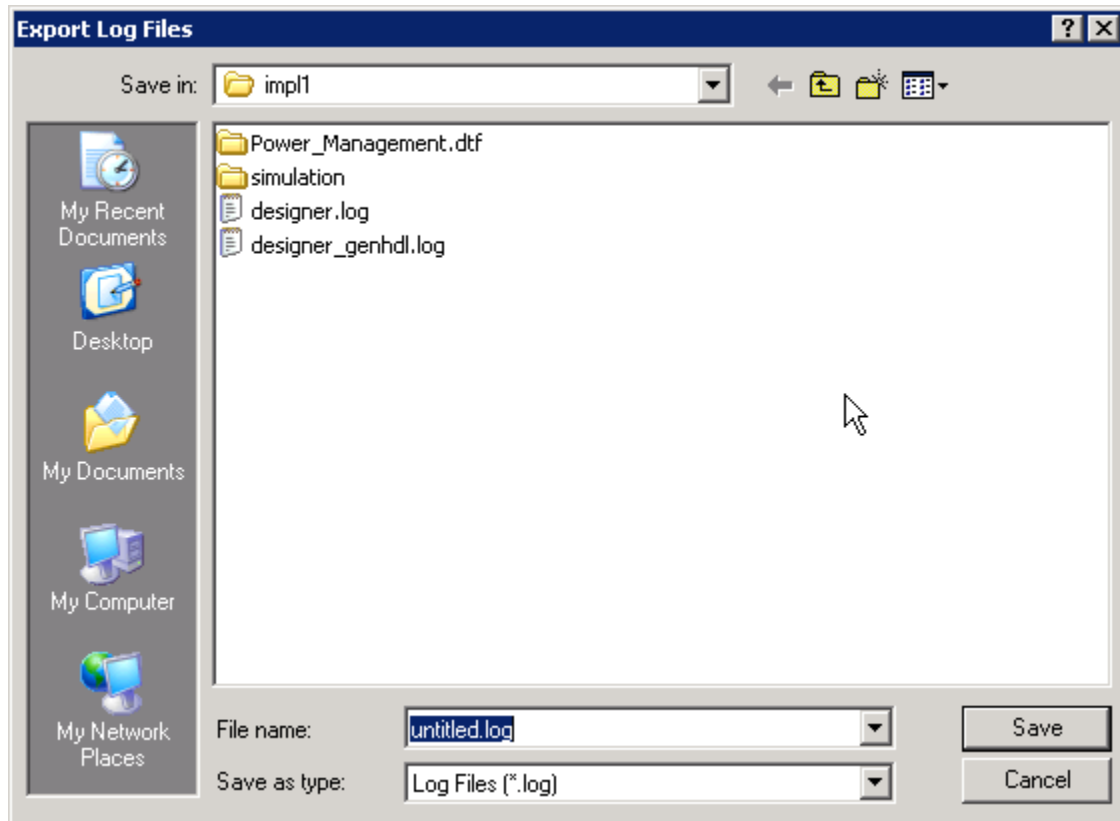

Figure 132 · Export Script / Log Files Dialog Box

**Save in**

Specifies the location of the file you are about to save.

**File name**

Specifies the filename of your new Tcl script or log file.

**Save as type**

Depending on your dialog box, saves the file as a LOG (\*.log) file or a TCL (\*.tcl) file

## Generate a programming file dialog box (Designer)

The Generate a programming file dialog box that appears depends on which device you are using.

If you are using a family that uses FlashPoint, the [FlashPoint dialog box](#) opens.

If you are using a family that uses a [bitstream or STAPL file for programming](#), the dialog box is slightly different.

If you are generating a fuse file for programming an antifuse device (such as SX-A), the [Generate a Fuse file dialog box](#) appears.



## Migration Options dialog box - ProASIC3/E to IGLOO/e and ProASIC3/E to ProASIC3L

The ProASIC3/E to IGLOO and ProASIC3/E to ProASIC3L Migration Options dialog box appears only when you change your device family from ProASIC3/E to IGLOO or ProASIC3L.

It enables you to set IGLOO and ProASIC3L die voltage options before you re-compile your design.

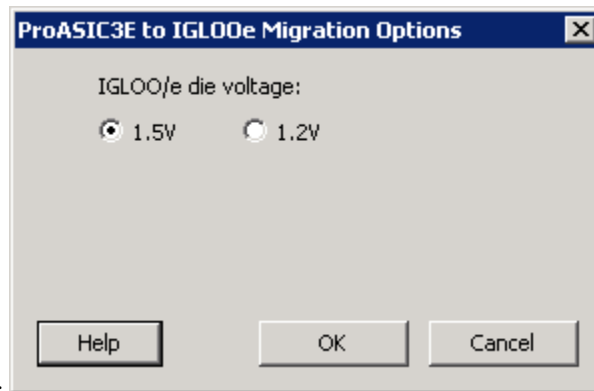

Figure 133 ·

Figure 134 · ProASIC3/E to IGLOO/e Migration Options Dialog Box

**IGLOO/e die voltage** - (option available only when migrating from ProASIC3/E to IGLOO/e) Set your die voltage to 1.5V or 1.2V.

Click **Cancel** to cancel out of the setup without making any changes.

## Open dialog box (Designer)

Use the Open dialog box to open files in Designer. This dialog box appears when you select File > Open in Designer.

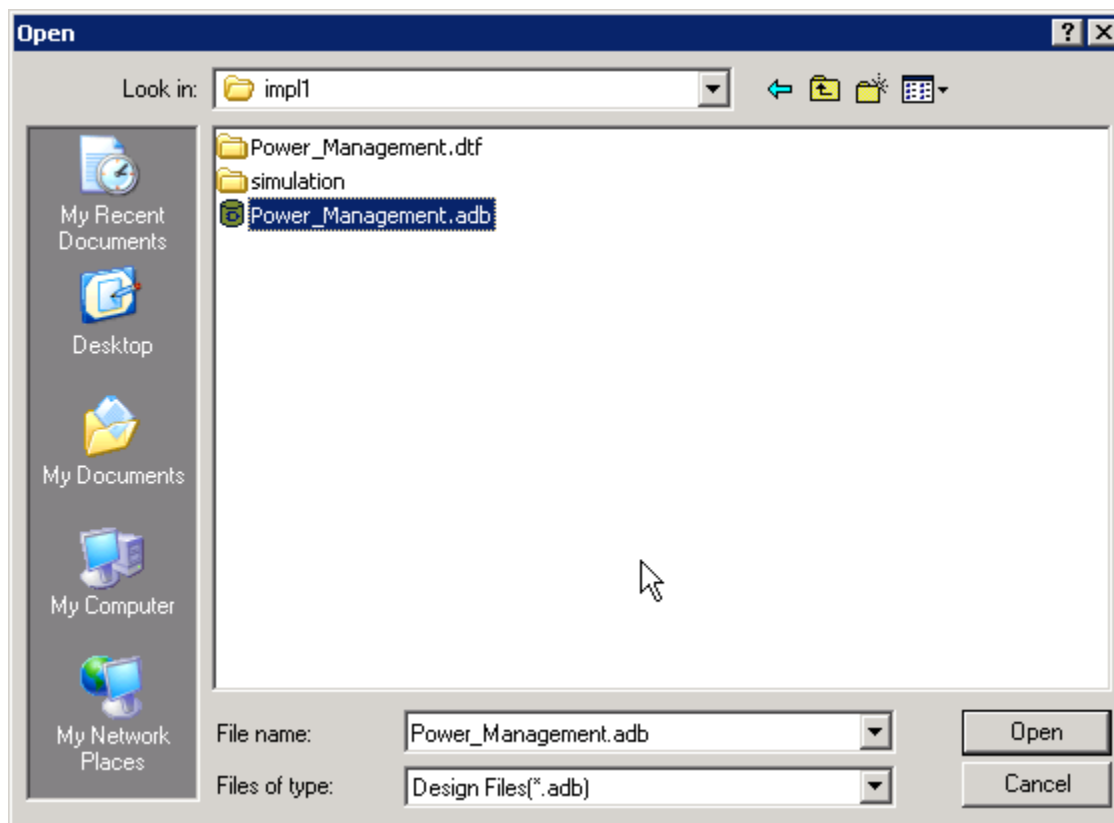

Figure 135 · Open Dialog Box (Designer)

**Look in**

Specifies from which directory you want to open the file. Navigate to a different directory if necessary.

**File name**

Specify a filename; type in part of a filename to filter files by that name.

**Files of type**

Select a file type from the drop-down menu to display only files of that type.

## SDC Export Options dialog box

To access this dialog, from the **File** menu, choose **Export>Constraint Files**, select **SDC Files (\*.sdc)** as the type, and then click **Save**.

Use this dialog box to specify the scenario, the SDC variant and the pin separator in your exported SDC file. Options include:

- **Export this scenario:** Select which scenario the files will be imported to.

- **SDC Variant:** The SDC variant is useful if you are using SmartTime extensions to evaluate your design. The extensions may not be supported by non-Actel tools. If you are using non-Actel tools to perform timing analysis, select **Standard-compliant**.
- **Pin Separator Character:** Select the pin separator character.

**Note:** Note: Clicking Cancel closes this dialog box without exporting the SDC file.

## Setup Design dialog box (Designer)

The Setup Design dialog box opens when you select File > New, or when you select Tools > Setup Design. Use it to specify your design name, enable Designer Blocks, select your family, and specify your working directory.

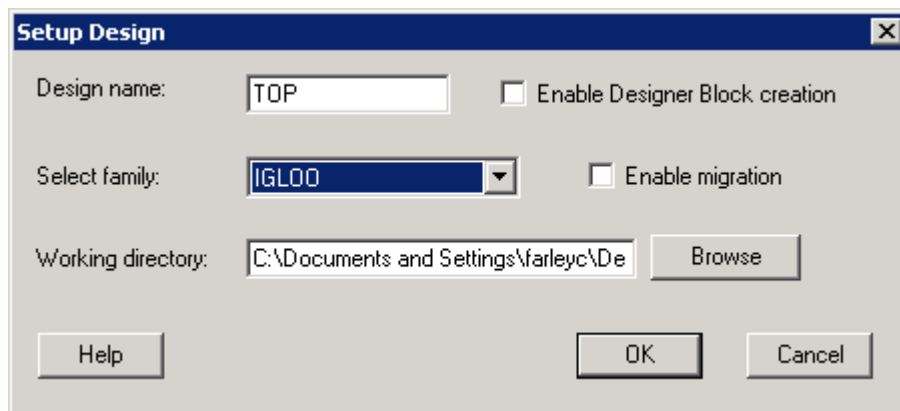

Figure 136 · Setup Design Dialog Box

### Design Name

The name of the ADB file for your design. No spaces are allowed.

### Enable Designer Block creation

Enables you to develop and [publish Designer Blocks](#). Blocks are useful if you want to re-use the same elements in several designs. Once you place-and-route your block and publish, the performance for the block will not change. If you Enable Designer Block creation you cannot program your part, only publish your Designer Block.

### Select Family

Choose or change your device family in the drop-down menu.

### Enable migration (ProASIC3 only)

Click enable migration if you wish to migrate from a ProASIC3 device to an IGLOO device. The checkbox is enabled only if you are using a ProASIC3 device with a device and package that is compatible with IGLOO. If you choose to enable migration, the [ProASIC3 to IGLOO Migration Options](#) dialog box appears.

### Working Directory

Set or change the working directory for your design.

## Variables Console dialog box

The Variables Console provides direct access to internal settings of the Designer software. Although the Variables Console enables you to inspect and modify the internal settings, normally you do not need to do so, and making incorrect changes can result in adverse software behavior. Under certain circumstances, Actel Technical Support may walk you through instructions on how to view or change a setting using the Variables Console in Designer.

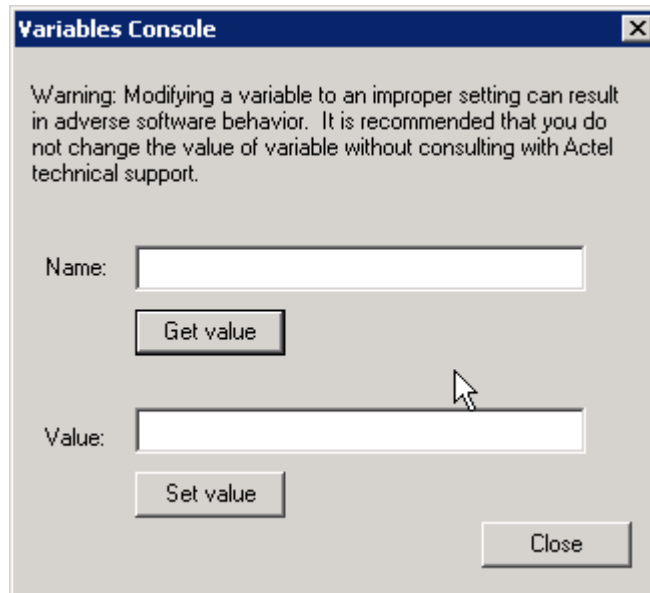





Figure 137 · Variables Console Dialog Box

## Designer File Menu

New		CTRL + N	Opens the Setup Design dialog box and prompts you to enter a design name, select a family, and specify a working directory
Open		CTRL + O	Opens the Designer Open file dialog box; enables you to select a file to open
Close			Closes the current file
Save		CTRL + S	Saves changes to the current file
Save As			Enables you to save the file as a different type (such as TXT)
Execute Script		CTRL	Opens the Execute Script dialog box; use it to enter

		+ U	arguments and run Tcl scripts.
Import Source Files			Opens the Import Source Files dialog box; enables you to select and import source files (such as netlist and constraint files). Source files are audited to coordinate your design changes.
Import Auxiliary Files			Opens the Import Auxiliary Files dialog box. Aux files are not audited; if you make changes to an auxiliary file after you import it, Designer does not ask you to re-import the file.
Audit Settings			Opens the Audit Settings dialog box; enables you to view all the source files, change their location, and copy them to your local directory.
Export			Lists all the file types you can <a href="#">export</a> in Designer.
Preferences			Opens the Designer Preferences dialog box
List of recent designs			Select a design from the list to open it.
Exit			Exits Designer

## Designer View menu











The View menu enables you to select which of the Designer elements you wish to display. You can choose to display (or hide) the standard tools (buttons for New, Open, Save, and About), the Design Tools (Compile, Layout, Back-annotate, Generate Programming File, and other tools), the Status Bar, and the Log Window.





## Designer Tools menu

The list of Tools varies according to your device family. Some tools, such as SmartTime and ChipPlanner, are not supported by all families. For a complete list of tools supported by each family, see the help for that tool.

Command	Icon	Function
Setup Design		Opens the Setup Design dialog box. Enter a design name, select a family, and specify a working directory for your design. You must save your design to commit your changes.

## Dialog Boxes

Command	Icon	Function
Device Selection		Opens the <a href="#">Device Selection Wizard</a> so you can set your die, package, speed grade, die voltage, reserve pins, etc.
Compile		Compiles the design
Layout		Opens the Layout Options dialog box; select your options and click OK to run layout.
Back-Annotate		Opens the <a href="#">Back-Annotate</a> dialog box; Back-Annotation creates the files necessary for back-annotation to the CAE file output type that you choose.
Generate Programming File		Opens the <a href="#">Generate Programming File</a> dialog box; set your file type, silicon signature and output filename to generate the file.
Generate Probed Design		Opens the Generate Probed Design dialog box; enables you to <a href="#">add a probe</a> to your IGLOO, ProASIC3, SmartFusion and Fusion design.
Generate FPGA Array Data File		Opens the Export FPGA Array Data File dialog box; the FPGA Array Data File (*.fdb) contains the FPGA map file and design-related information. The FDB file is required for programming in FlashPro.
Netlist Viewer		Starts Netlist Viewer, either <a href="#">on its own</a> or <a href="#">in the MVN interface</a> , depending on your device
PinEditor		Starts PinEditor, either <a href="#">on its own</a> or <a href="#">in the MVN interface</a> , depending on your device
ChipPlanner		Starts <a href="#">ChipPlanner</a> in the MVN interface; use ChipPlanner to create, edit, and assign logic to regions in your design
ChipEditor		Starts <a href="#">ChipEditor</a>
I/O Attribute Editor		Starts the <a href="#">I/O Attribute Editor</a> in the MVN Interface; use this tool to view, sort, select, and delete I/O attributes in your design
SmartTime		Starts the <a href="#">SmartTime Constraints Editor</a> ; use this tool to edit your

Command	Icon	Function
Constraints Editor		timing constraints
SmartTime Timing Analyzer		Starts the <a href="#">SmartTime Timing Analyzer</a> ; use this tool to perform timing analysis on your design
SmartPower		Starts <a href="#">SmartPower</a> ; use this tool to analyze power usage in your design
I/O Advisor		Starts the <a href="#">I/O Advisor</a> ; use this tool to balance the timing and power consumption of the I/Os in your design.
Timer		Starts <a href="#">Timer</a> ; use this tool to perform timing analysis on your design
Reports		Opens the <a href="#">Report Types</a> dialog box; select a report type and click OK to generate the report
Customize		Opens the Customize User Tools dialog box; use this dialog box to <a href="#">add other applications</a> to the Designer Tools menu (PC only)

## Designer Options menu

Netlist Import	Enables you to select your <a href="#">Verilog</a> and <a href="#">EDIF</a> netlist options.
Compile	Opens the <a href="#">Compile options</a> dialog box. This is not the same command as clicking the Compile button in Designer.
Variables Console	The Variables Console provides direct access to internal settings of the Designer software. Although the Variables Console enables you to inspect and modify the internal settings, normally you do not need to do so, and making incorrect changes can result in adverse software behavior. Under certain circumstances, Actel Technical Support may walk you through instructions on how to view or change a setting using the Variables Console in Designer.
Clear Log	Clears the Log window in Designer.

## Designer Help menu

The Help menu enables you to access the Designer online help, reference manuals, check for updates, and view your license and version information.

<b>Command</b>	<b>Function</b>
Help Topics	Opens the Libero IDE online help
Reference Manuals	Opens the list of manuals (PDF files) available for Designer, including links to library guides, and PDF versions of the online help.
Actel Technical Support	Displays the Actel customer support web page in your default browser
Actel Web Site	Displays the main Actel page in your default browser
Check for Software Updates	Checks for updates to the Designer software
License Details	Displays detailed license information for your version of Designer.
About Actel Designer Software	Displays version and release numbers for your Designer software



---

## Product Support

Actel backs its products with various support services including Customer Service, a Customer Technical Support Center, a web site, an FTP site, electronic mail, and worldwide sales offices. This appendix contains information about contacting Actel and using these support services.

### Customer Service

Contact Customer Service for non-technical product support, such as product pricing, product upgrades, update information, order status, and authorization.

From Northeast and North Central U.S.A., call **650.318.4480**

From Southeast and Southwest U.S.A., call **650.318.4480**

From South Central U.S.A., call **650.318.4434**

From Northwest U.S.A., call **650.318.4434**

From Canada, call **650.318.4480**

From Europe, call **650.318.4252** or **+44 (0) 1276 401 500**

From Japan, call **650.318.4743**

From the rest of the world, call **650.318.4743**

Fax, from anywhere in the world **650.318.8044**

### Actel Customer Technical Support Center

Actel staffs its Customer Technical Support Center with highly skilled engineers who can help answer your hardware, software, and design questions. The Customer Technical Support Center spends a great deal of time creating application notes and answers to FAQs. So, before you contact us, please visit our online resources. It is very likely we have already answered your questions.

### Actel Technical Support

Visit the [Actel Customer Support website](http://www.actel.com/support/search/default.aspx) (<http://www.actel.com/support/search/default.aspx>) for more information and support. Many answers available on the searchable web resource include diagrams, illustrations, and links to other resources on the Actel web site.

### Website

You can browse a variety of technical and non-technical information on Actel's [home page](http://www.actel.com/), at <http://www.actel.com/>.

### Contacting the Customer Technical Support Center

Highly skilled engineers staff the Technical Support Center from 7:00 A.M. to 6:00 P.M., Pacific Time, Monday through Friday. Several ways of contacting the Center follow:

#### Email

You can communicate your technical questions to our email address and receive answers back by email, fax, or phone. Also, if you have design problems, you can email your design files to receive assistance. We constantly monitor the email account throughout the day. When sending your request to us, please be sure to include your full name, company name, and your contact information for efficient processing of your request.

The technical support email address is [tech@actel.com](mailto:tech@actel.com).

## Phone

Our Technical Support Center answers all calls. The center retrieves information, such as your name, company name, phone number and your question, and then issues a case number. The Center then forwards the information to a queue where the first available application engineer receives the data and returns your call. The phone hours are from 7:00 A.M. to 6:00 P.M., Pacific Time, Monday through Friday. The Technical Support numbers are:

**650.318.4460**

**800.262.1060**

Customers needing assistance outside the US time zones can either contact technical support via email ([tech@actel.com](mailto:tech@actel.com)) or contact a local sales office. [Sales office listings](#) can be found at [www.actel.com/company/contact/default.aspx](http://www.actel.com/company/contact/default.aspx).





**Actel is the leader in low-power and mixed-signal FPGAs and offers the most comprehensive portfolio of system and power management solutions. Power Matters. Learn more at <http://www.actel.com> .**

**Actel Corporation** • 2061 Stierlin Court • Mountain View, CA 94043 • USA

Phone 650.318.4200 • Fax 650.318.4600 • Customer Service: 650.318.1010 • Customer Applications Center: 800.262.1060

**Actel Europe Ltd.** • River Court, Meadows Business Park • Station Approach, Blackwater • Camberley Surrey GU17 9AB • United Kingdom  
Phone +44 (0) 1276 609 300 • Fax +44 (0) 1276 607 540

**Actel Japan** • EXOS Ebisu Building 4F • 1-24-14 Ebisu Shibuya-ku • Tokyo 150 • Japan  
Phone +81.03.3445.7671 • Fax +81.03.3445.7668 • <http://ljp.actel.com>

**Actel Hong Kong** • Room 2107, China Resources Building • 26 Harbour Road • Wanchai • Hong Kong  
Phone +852 2185 6460 • Fax +852 2185 6488 • [www.actel.com.cn](http://www.actel.com.cn)