

## Features

- Full Wave Current Sensing
- Compensated Mains Supply Variations
- Variable Soft Start or Load-current Sensing
- Voltage and Current Synchronization
- Switchable Automatic Retriggering
- Triggering Pulse Typically 125 mA
- Internal Supply-voltage Monitoring
- Current Requirement  $\leq 3$  mA

## Applications

- Low-cost Motor Control
- Domestic Appliance

## 1. Description

The U2008B is designed as a phase-control circuit in bipolar technology. It enables load-current detection as well as mains-compensated phase control. Motor control with load-current feedback and overload protection are preferred applications.

**Figure 1-1.** Block Diagram with Typical Circuit: Load Current Sensing

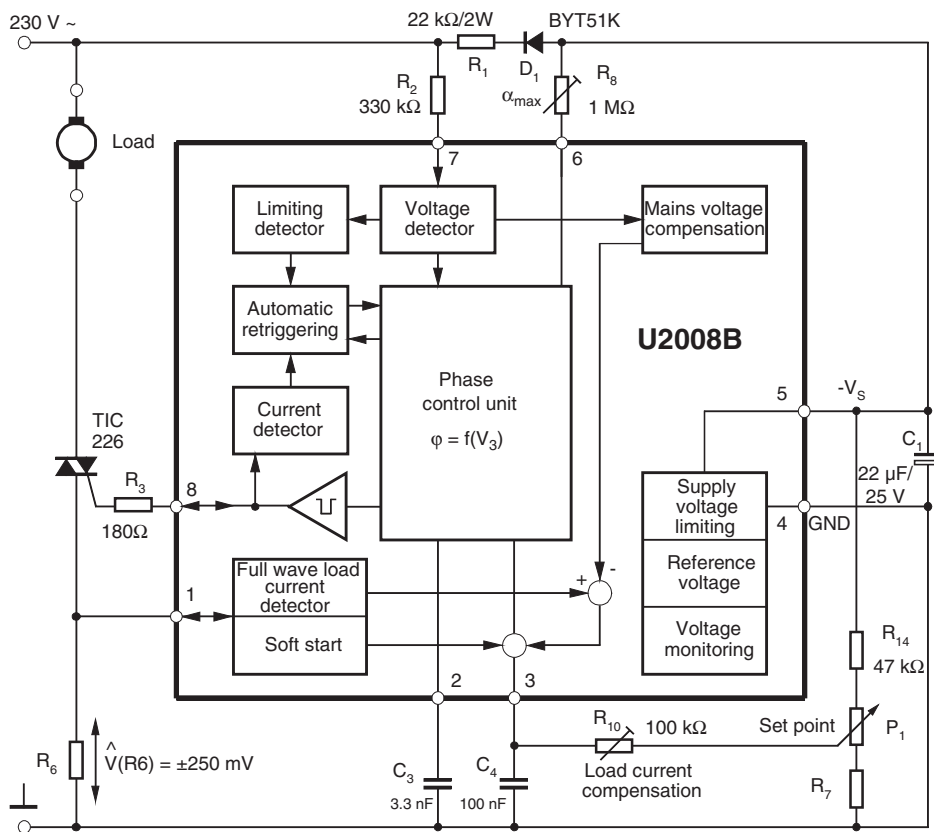

## Low-cost Phase-control IC with Soft Start

## U2008B

**Figure 1-2. Block Diagram with Typical Circuit: Soft Start**

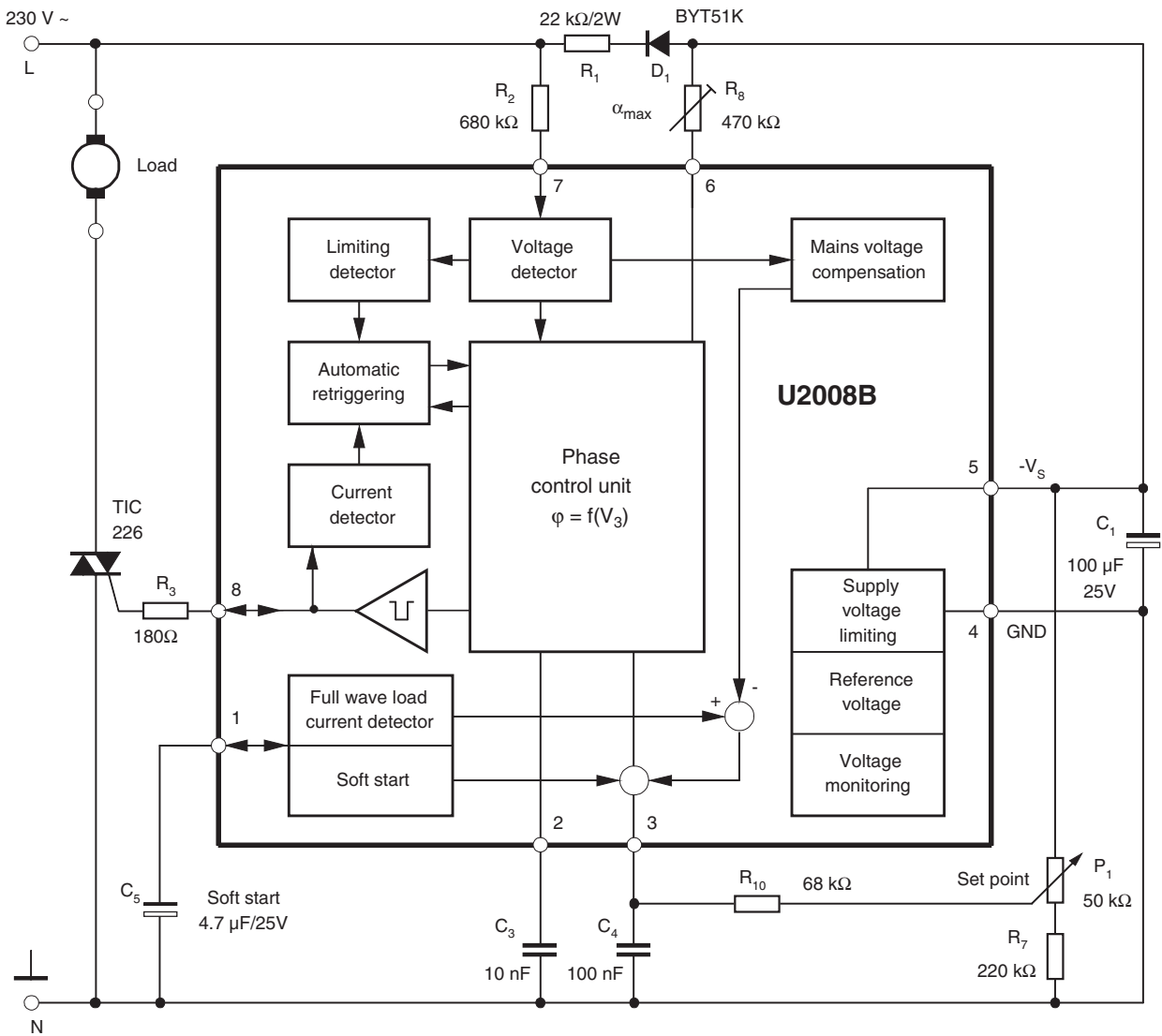

## 2. Pin Configuration

Figure 2-1. Pinning

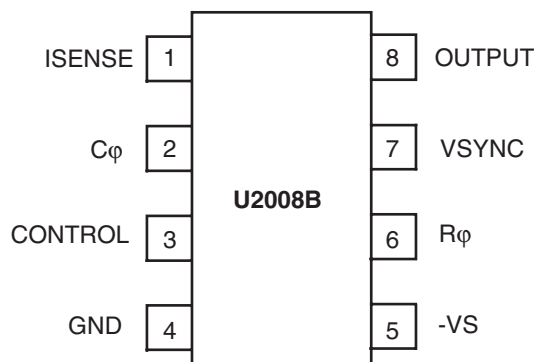

Table 2-1. Pin Description

Pin	Symbol	Function
1	ISENSE	Load current sensing
2	C <sub>φ</sub>	Ramp voltage
3	CONTROL	Control input/compensation output
4	GND	Ground
5	-VS	Supply voltage
6	R <sub>φ</sub>	Ramp current adjustment
7	VSYNC	Voltage synchronization
8	OUTPUT	Trigger output

### 2.1 Mains Supply, Pin 5

The integrated circuit U2008B, which also contains voltage limiting, can be connected via D<sub>1</sub> and R<sub>1</sub> to the mains supply, see [Figure 1-2 on page 2](#). Supply voltage, between Pin 4 (pos., ⊥) and Pin 5, is smoothed by C<sub>1</sub>.

The series resistance R1 can be calculated as follows:

$$R_{1\max} = 0.85 \times \frac{V_M - V_{S\max}}{2 \times I_{\text{tot}}}$$

where:

- V<sub>M</sub> = Mains voltage
- V<sub>Smax</sub> = Maximum supply voltage
- I<sub>tot</sub> = I<sub>Smax</sub> + I<sub>x</sub> = Total current compensation
- I<sub>Smax</sub> = Maximum current consumption of the IC
- I<sub>x</sub> = Current consumption of the external components

Operation with externally stabilized DC voltage is not recommended.

## 2.2 Voltage Monitoring

When the voltage is built up, uncontrolled output pulses are avoided by internal voltage monitoring. Apart from that, all latches of the circuit (phase control, load limit regulation) are reset and the soft start capacitor is short circuited. This guarantees a specified start-up behavior each time the supply voltage is switched on or after short interruptions of the mains supply. Soft start is initiated after the supply voltage has been built up. This behavior guarantees a gentle start-up for the motor and automatically ensures the optimum run-up time.

## 2.3 Phase Control, Pin 6

The function of the phase control is identical to that of the well-known IC U211B. The phase angle of the trigger pulse is derived by comparing the ramp voltage  $V_2$  at Pin 2 with the set value on the control input, Pin 3. The slope of the ramp is determined by  $C_3$  and its charging current  $I_{\phi}$ .

The charging current can be regulated, changed or altered using  $R_8$  at Pin 6.

The maximum phase angle,  $\alpha_{\max}$ , (minimum current flow angle  $\phi_{\min}$ ) can also be adjusted by using  $R_8$  (see [Figure 5-1 on page 7](#)).

When the potential on Pin 2 reaches the set point level of Pin 3, a trigger pulse is generated whose pulse width,  $t_p$ , is determined from the value of  $C_3$  ( $t_p = 9 \mu\text{s/nF}$ , [Figure 5-3 on page 8](#)). At the same time, a latch is set with the output pulse, as long as the automatic retriggering has not been activated, then no more pulses can be generated in that half cycle. Control input at Pin 3 (with respect to Pin 4) has an active range from -9 V to -2 V. When  $V_3 = -9$  V the phase angle is at its maximum  $\alpha_{\max}$ , i.e., the current flow angle is minimum. The minimum phase angle  $\alpha_{\min}$  is set with  $V_3 \geq -1$  V.

## 2.4 Automatic Retriggering

The current-detector circuit monitors the state of the triac after triggering by measuring the voltage drop at the triac gate. A current flow through the triac is recognized when the voltage drop exceeds a threshold level of typically 40 mV.

If the triac is quenched within the relevant half wave after triggering (for example owing to low load currents before or after the zero crossing of current wave, or for commutator motors, owing to brush lifters), the automatic retriggering circuit ensures immediate retriggering, if necessary with a high repetition rate,  $t_{pp}/t_p$ , until the triac remains reliably triggered.

## 2.5 Current Synchronization, Pin 8

Current synchronization fulfils two functions:

- Monitoring the current flow after triggering. In case the triac extinguishes again or it does not switch on, automatic triggering is activated as long as triggering is successful.
- Avoiding triggering due to inductive load. In the case of inductive load operation, the current synchronization ensures that in the new half wave no pulse is enabled as long as there is a current available from the previous half wave, which flows from the opposite polarity to the actual supply voltage.

A special feature of the IC is the realization of current synchronization. The device evaluates the voltage at the pulse output between the gate and reference electrode of the triac. This results in saving the separate current synchronization input with specified series resistance.

## 2.6 Voltage Synchronization with Mains Voltage Compensation, Pin 7

The voltage detector synchronizes the reference ramp with the mains supply voltage. At the same time, the mains-dependent input current at Pin 7 is shaped and rectified internally. This current activates automatic retriggering and at the same time is available at Pin 3 (Figure 5-5 on page 9). By suitable dimensioning, it is possible to attain the specified compensation effect. Automatic retriggering and mains voltage compensation are not activated until  $|V_7 - V_4|$  increases to 8 V. The resistance  $R_{sync}$  defines the width of the zero voltage cross-over pulse, synchronization current, and hence the mains supply voltage compensation current. If the mains voltage compensation and the automatic retriggering are not required, both functions can be suppressed by limiting  $|V_7 - V_4| \leq 7$  V (see Figure 2-2).

**Figure 2-2.** Suppression of Automatic Retriggering and Mains Voltage Compensation

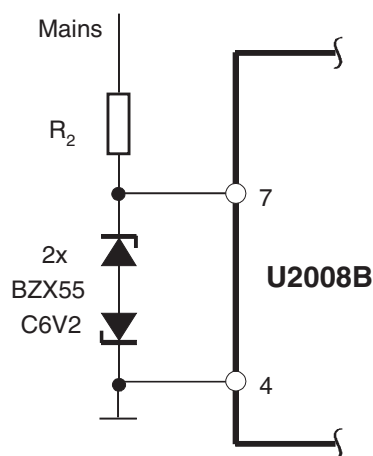

A further feature of the IC is the selection between soft start and load-current compensation. Soft start is possible by connecting a capacitor between Pin 1 and Pin 4 (Figure 5-4 on page 8). In the case of load-current compensation, Pin 1 is directly connected with resistance  $R_6$ , which is used for sensing load current.

## 2.7 Load Current Detection, Pin 1

The circuit continuously measures the load current as a voltage drop at resistor  $R_6$ . The evaluation and use of both half waves results in a quick reaction to load-current change. Due to voltage at resistor  $R_6$ , there is an increase of input current at Pin 1. This current increase controls the internal current source, whose positive current values are available at Pin 3 (see Figure 5-7 on page 9). The output current generated at Pin 3 contains the difference from the load-current detection and the mains-voltage compensation (see Figure 5-5 on page 9).

The effective control voltage is the final current at Pin 3 together with the desired value network. An increase of mains voltage causes an increase of the control angle  $\alpha$ . An increase of load current results in a decrease of the control angle. This avoids a decrease in revolution by increasing the load as well as an increase of revolution by the increment of mains supply voltage.

### 3. Absolute Maximum Ratings

$V_S = 14\text{ V}$ , reference point Pin 4, unless otherwise specified

Parameters	Symbol	Value	Unit
Current limitation Pin 5 $t \leq 10\ \mu\text{s}$	$-I_S$	30	mA
	$-i_S$	100	mA
Synchronous currents Pin 7 $t \leq 10\ \mu\text{s}$	$\pm I_{\text{syncV}}$	5	mA
	$\pm i_{\text{syncV}}$	20	mA
<b>Phase Control Pin 3</b>			
Control voltage	$-V_I$	$V_S$ to 0	V
Input current	$\pm I_I$	500	mA
Charge current Pin 6	$-I_{\phi\text{max}}$	0.5	mA
<b>Load Current Monitoring/Soft Start, Pin 1</b>			
Input current	$I_I$	1	mA
Input voltage	$V_I$	$-V_S$ to +2	V
Pulse output			
Input voltage Pin 8	$+V_I$	2	V
	$-V_I$	$V_S$	V
Storage temperature range	$T_{\text{stg}}$	-40 to +125	$^{\circ}\text{C}$
Junction temperature range	$T_j$	-10 to +125	$^{\circ}\text{C}$

### 4. Thermal Resistance

Parameters		Symbol	Value	Unit
Junction ambient	DIP8	$R_{\text{thJA}}$	110	K/W
	SO8 on p.c.	$R_{\text{thJA}}$	220	K/W
	So8 on ceramic	$R_{\text{thJA}}$	140	K/W

### 5. Electrical Characteristics

Parameters	Test Conditions	Symbol	Min.	Typ.	Max.	Unit
<b>Supply (Pin 5)</b>						
Supply-voltage limitation	$-I_S = 3.5\ \text{mA}$	$-V_S$	14.5		16.5	V
	$-I_S = 30\ \text{mA}$	$-V_S$	14.6		16.8	V
Current requirement	Pins 1, 4 and 7 open	$-I_S$			3.0	mA
<b>Voltage Monitoring (Pin 5)</b>						
Turn-on threshold		$-V_{\text{TON}}$		11.3	12.3	V
<b>Phase Control</b>						
Input current	Voltage sync. Pin 7 Current sync. Pin 8	$\pm I_{\text{syncV}}$		0.15	2	mA
		$\pm I_{\text{syncI}}$	3		30	$\mu\text{A}$
Voltage limitation	$\pm I_L = 2\ \text{mA}$ Pin 7	$\pm V_{\text{syncV}}$	8.0	8.5	9.0	V
<b>Reference Ramp (see Figure 5-1 on page 7)</b>						
Charge current	Pin 7	$I_{\phi}$	1		100	$\mu\text{A}$
Start voltage	Pin 2	$-V_{\text{max}}$	1.85	1.95	2.05	V

## 5. Electrical Characteristics (Continued)

Parameters	Test Conditions	Symbol	Min.	Typ.	Max.	Unit
Temperature coefficient of start voltage	Pin 2	$-TC_R$		-0.003		%/K
$R_\phi$ - reference voltage	$I_\phi = 10 \mu\text{A}$ , Pins 6 to 5	$V_{R\phi}$	0.96	1.02	1.10	V
Temperature coefficient	$I_\phi = 10 \mu\text{A}$ , Pin 6 $I_\phi = 1 \mu\text{A}$	$TC_{VR\phi}$		0.03		%/K
		$TC_{VR\phi}$		0.06		%/K
<b>Pulse Output (see Figure 5-2 on page 8) (Pin 8)</b>						
Output-pulse current	$V_8 = -1.2$ , $R_{GT} = 0 \Omega$	$I_0$	100	125	150	mA
Output-pulse width	$C_3 = 3.3 \text{ nF}$ , $V_S = V_{\text{limit}}$	$t_p$		30		$\mu\text{s}$
<b>Automatic Retriggering (Pin 8)</b>						
Turn-on threshold voltage		$\pm V_{\text{ION}}$	20		60	mV
Repetition rate	$I_7 \geq 150 \mu\text{A}$	$t_{pp}$	3	5	7.5	$t_p$
<b>Soft Start (see Figure 5-4 on page 8) (Pin 1)</b>						
Starting current	$V_{1-4} = 8 \text{ V}$	$I_0$	5	10	15	$\mu\text{A}$
Final current	$V_{1-4} = -2 \text{ V}$	$I_0$	15	25	40	$\mu\text{A}$
Discharge current		$-I_0$	0.5			mA
Output current	Pin 3	$-I_0$	0.2		2	mA
<b>Mains Voltage Compensation (see Figure 5-5 on page 9)</b>						
Current transfer gain $I_7/I_3$	Pins 7, Pin 3 Pins 1 and 2 open	$G_i$	14	17	20	
Reverse current	$V_{(R6)} = V_3 = V_7 = 0$ , Pin 3	$\pm I_R$			2	$\mu\text{A}$
<b>Load-current Detection, <math>V_7 = 0</math> (see Figure 5-7 on page 9)</b>						
Transfer gain	$I_3/V_1$	$G$	0.28	0.32	0.37	$\mu\text{A/mV}$
Offset current	$V_1 = 0$ , $V_3 = -8 \text{ V}$ , Pin 3	$I_0$	0	3	6	$\mu\text{A}$
Input voltage	Pin 1	$-V_1$	300		400	mV
Input offset voltage	Pin 1	$\pm V_0$			6	mV

Figure 5-1. Ramp Control

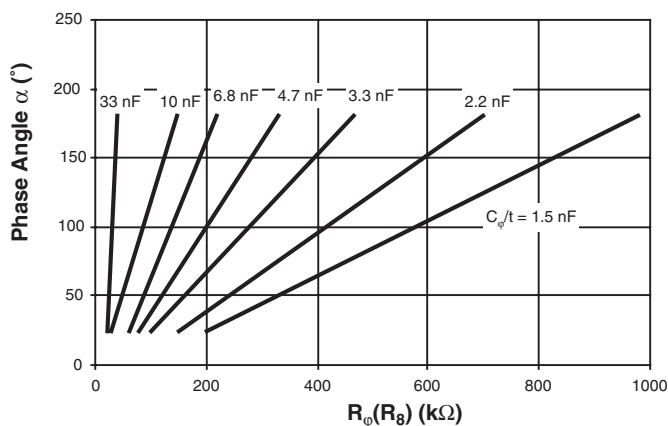

**Figure 5-2. Pulse Output**

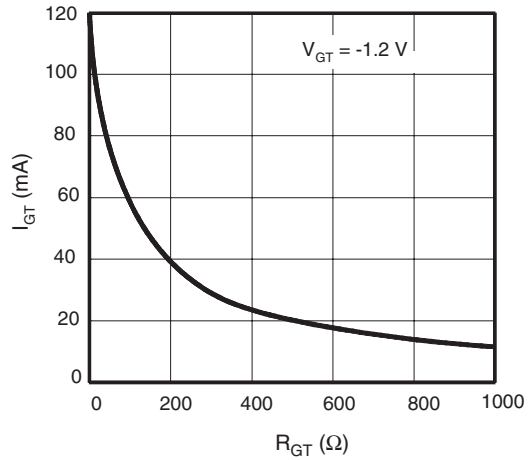

**Figure 5-3. Output Pulse Width**

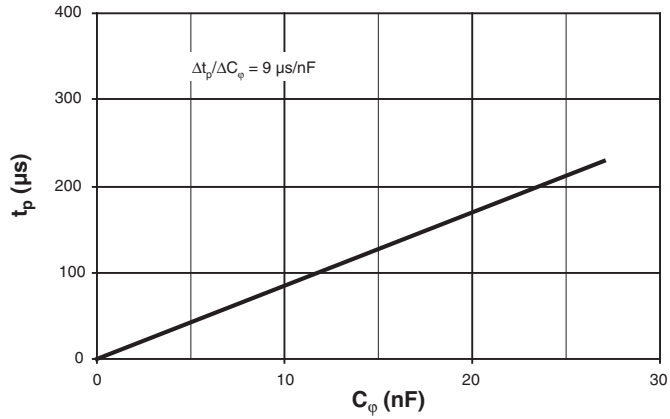

**Figure 5-4. Option Soft Start**

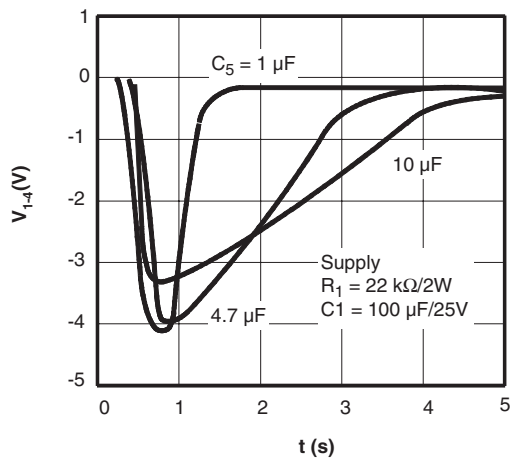



Figure 5-5. Mains Voltage Compensation

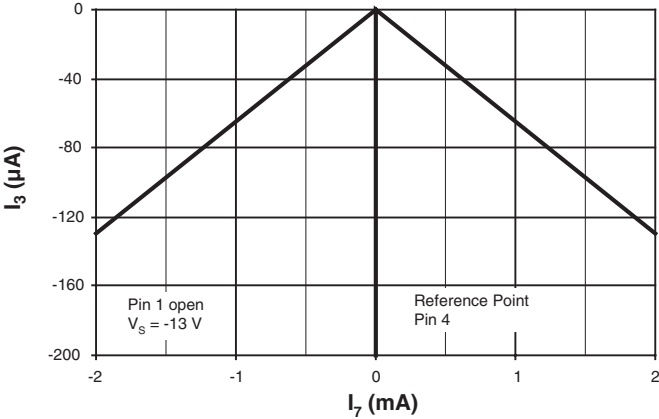

Figure 5-6. Maximum Resistance of  $R_1$

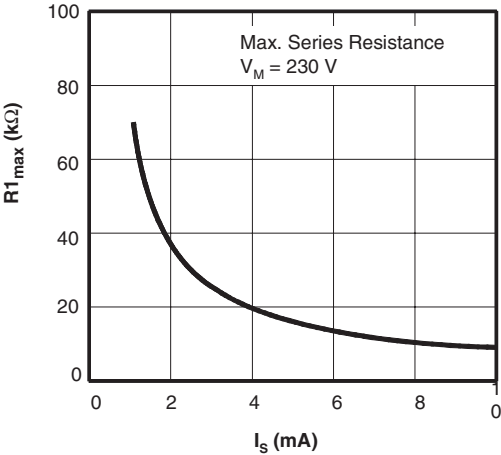
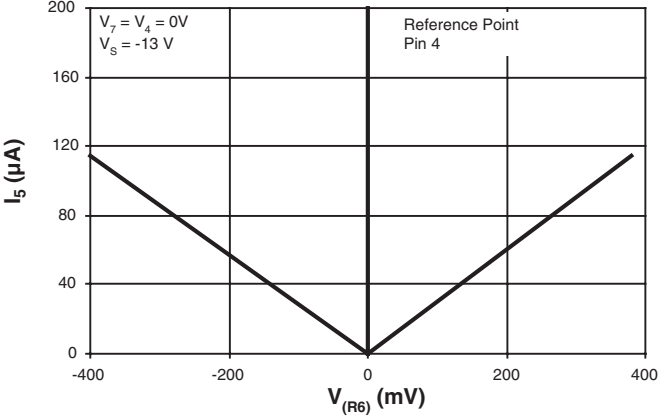
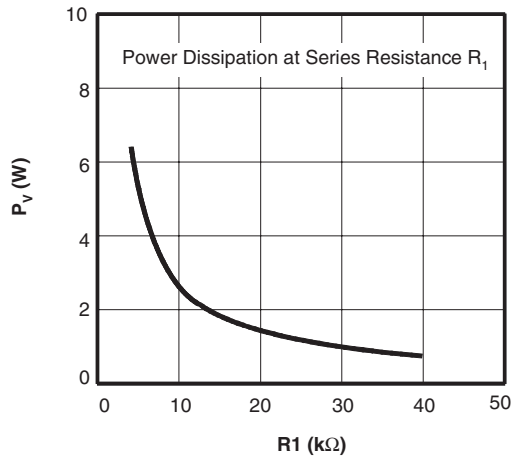

Figure 5-7. Load-current Detection



**Figure 5-8.** Power Dissipation of  $R_1$



**Figure 5-9.** Power Dissipation of  $R_1$  According to Current Consumption

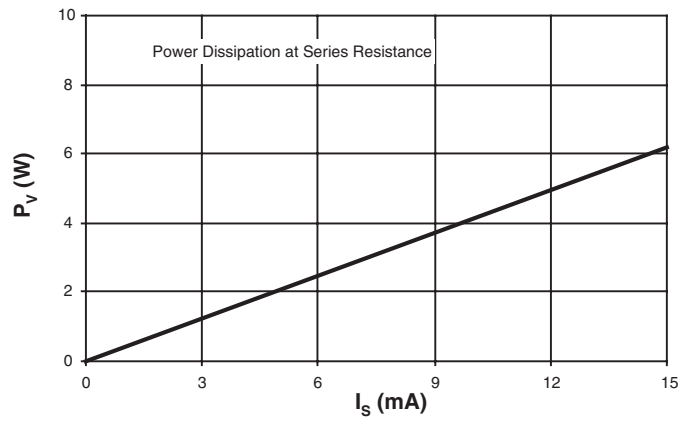

## 6. Ordering Information

Extended Type Number	Package	Remarks
U2008B-xY	DIP8	Tube, Pb-free
U2008B-xFPY	SO8	Tube, Pb-free
U2008B-xFPG3Y	SO8	Taped and reeled, Pb-free

## 7. Package Information

Package: DIP8  
Dimensions in mm

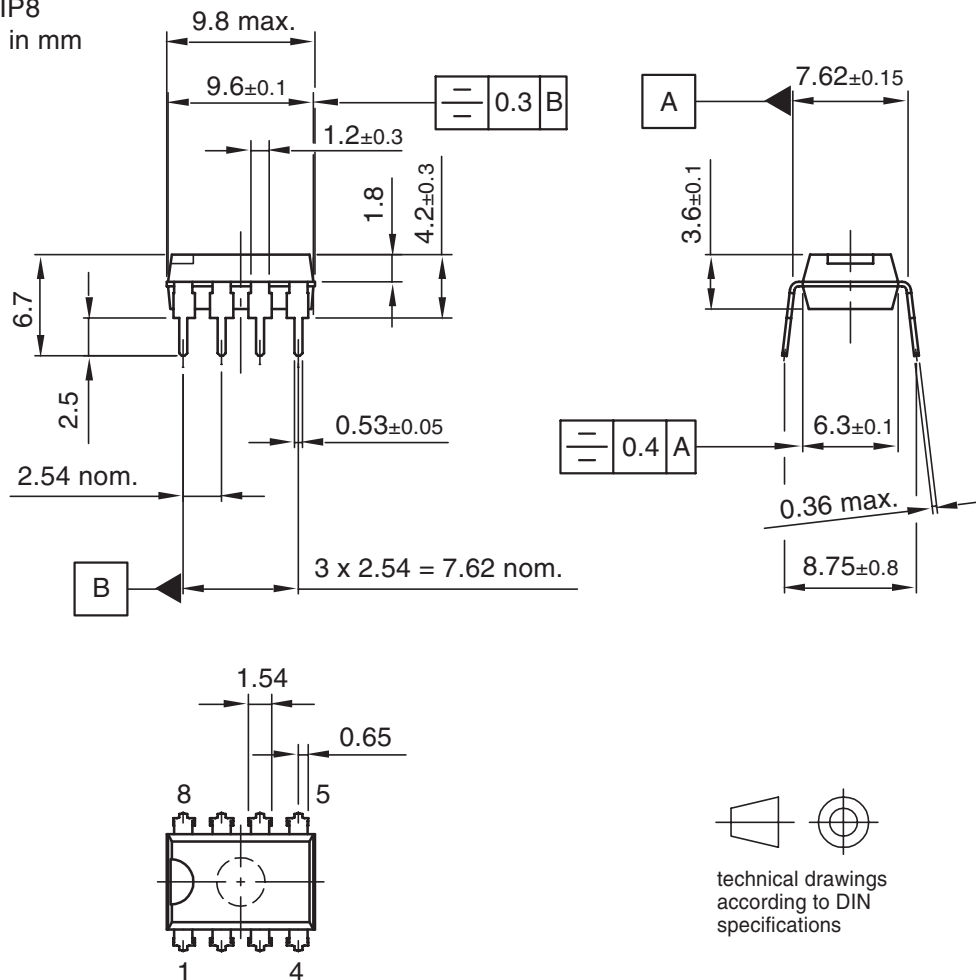

Drawing-No.: 6.543-5040.01-4

Issue: 1; 16.01.02

Package: SO 8

Dimensions in mm

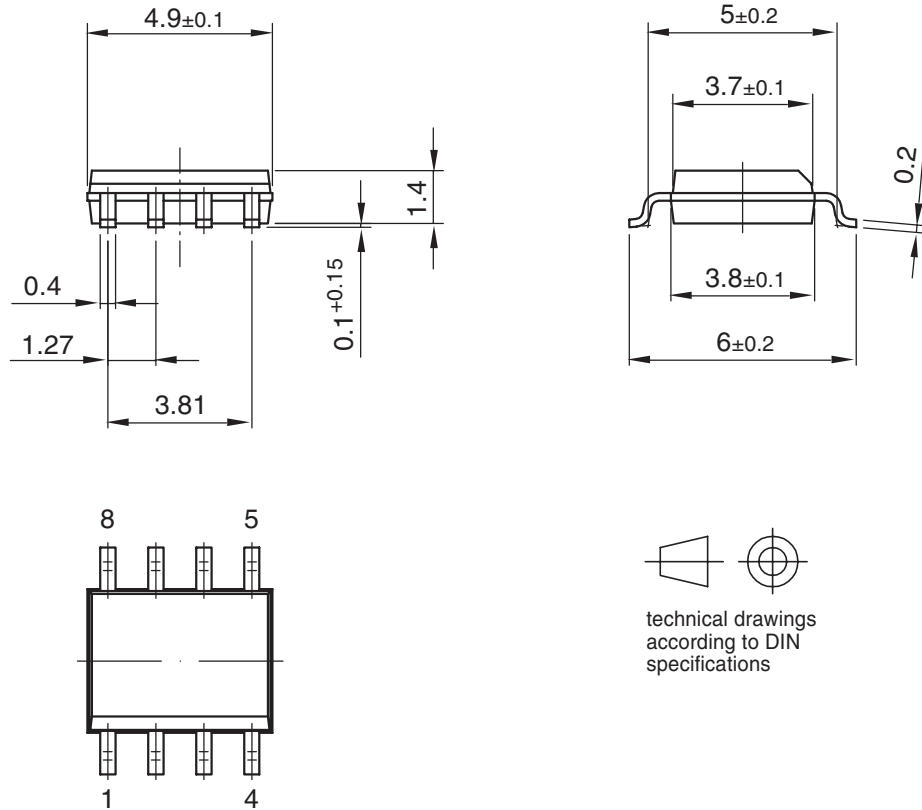

Drawing-No.: 6.541-5031.01-4

Issue: 1; 15.08.06

## 8. Revision History

Please note that the following page numbers referred to in this section refer to the specific revision mentioned, not to this document.

Revision No.	History
4712C-AUTO-07/07	<ul style="list-style-type: none"> <li>• Put datasheet in a new template</li> <li>• Pb-free logo on page 1 deleted</li> <li>• Figure 5-5 "Mains Voltage Compensation" on page 9 changed</li> <li>• Figure 5-7 "Load-current Detection" on page 9 changed</li> </ul>
4712B-AUTO-08/05	<ul style="list-style-type: none"> <li>• Put datasheet in a new template</li> <li>• First page: Pb-free logo added</li> <li>• Page 11: Ordering Information changed</li> </ul>



## Headquarters

---

**Atmel Corporation**  
2325 Orchard Parkway  
San Jose, CA 95131  
USA  
Tel: 1(408) 441-0311  
Fax: 1(408) 487-2600

## International

---

**Atmel Asia**  
Room 1219  
Chinachem Golden Plaza  
77 Mody Road Tsimshatsui  
East Kowloon  
Hong Kong  
Tel: (852) 2721-9778  
Fax: (852) 2722-1369

**Atmel Europe**  
Le Krebs  
8, Rue Jean-Pierre Timbaud  
BP 309  
78054  
Saint-Quentin-en-Yvelines Cedex  
France  
Tel: (33) 1-30-60-70-00  
Fax: (33) 1-30-60-71-11

**Atmel Japan**  
9F, Tonetsu Shinkawa Bldg.  
1-24-8 Shinkawa  
Chuo-ku, Tokyo 104-0033  
Japan  
Tel: (81) 3-3523-3551  
Fax: (81) 3-3523-7581

## Product Contact

---

**Web Site**  
[www.atmel.com](http://www.atmel.com)

**Technical Support**  
[auto\\_control@atmel.com](mailto:auto_control@atmel.com)

**Sales Contact**  
[www.atmel.com/contacts](http://www.atmel.com/contacts)

**Literature Requests**  
[www.atmel.com/literature](http://www.atmel.com/literature)

---

**Disclaimer:** The information in this document is provided in connection with Atmel products. No license, express or implied, by estoppel or otherwise, to any intellectual property right is granted by this document or in connection with the sale of Atmel products. **EXCEPT AS SET FORTH IN ATMEL'S TERMS AND CONDITIONS OF SALE LOCATED ON ATMEL'S WEB SITE, ATMEL ASSUMES NO LIABILITY WHATSOEVER AND DISCLAIMS ANY EXPRESS, IMPLIED OR STATUTORY WARRANTY RELATING TO ITS PRODUCTS INCLUDING, BUT NOT LIMITED TO, THE IMPLIED WARRANTY OF MERCHANTABILITY, FITNESS FOR A PARTICULAR PURPOSE, OR NON-INFRINGEMENT. IN NO EVENT SHALL ATMEL BE LIABLE FOR ANY DIRECT, INDIRECT, CONSEQUENTIAL, PUNITIVE, SPECIAL OR INCIDENTAL DAMAGES (INCLUDING, WITHOUT LIMITATION, DAMAGES FOR LOSS OF PROFITS, BUSINESS INTERRUPTION, OR LOSS OF INFORMATION) ARISING OUT OF THE USE OR INABILITY TO USE THIS DOCUMENT, EVEN IF ATMEL HAS BEEN ADVISED OF THE POSSIBILITY OF SUCH DAMAGES.** Atmel makes no representations or warranties with respect to the accuracy or completeness of the contents of this document and reserves the right to make changes to specifications and product descriptions at any time without notice. Atmel does not make any commitment to update the information contained herein. Unless specifically provided otherwise, Atmel products are not suitable for, and shall not be used in, automotive applications. Atmel's products are not intended, authorized, or warranted for use as components in applications intended to support or sustain life.

© 2007 Atmel Corporation. All rights reserved. Atmel®, logo and combinations thereof, and others are registered trademarks or trademarks of Atmel Corporation or its subsidiaries. Other terms and product names may be trademarks of others.