

MQ-2 MODULE

MQ-2 SMOKE METHANE GAS & LIQUEFIED FLAMMABLE GAS SENSOR MODULE



• DESCRIPTION

The analog gas sensor - MQ2 is used in gas leakage detecting equipments in consumer and industry markets, this sensor is suitable for detecting LPG, i-butane, Propane, Methane , Alcohol, Hydrogen and Smoke. It has a high sensitivity and fast response time and the sensitivity can be adjusted using the potentiometer.

Features

- Power supply needs: 5V
- Interface type: Analog
- Pin Definition: 1-Output 2-GND 3-VCC
- Wide detecting scope
- Fast response and High sensitivity
- Simple drive circuit
- Stable and long life

TECHNICAL DATA

MQ-2 GAS SENSOR

FEATURES

Wide detecting scope
Stable and long life

Fast response and High sensitivity
Simple drive circuit

APPLICATION

They are used in gas leakage detecting equipments in family and industry, are suitable for detecting of LPG, i-butane, propane, methane ,alcohol, Hydrogen, smoke.

SPECIFICATIONS

A. Standard work condition

Symbol	Parameter name	Technical condition	Remarks
V _c	Circuit voltage	5V±0.1	AC OR DC
V _H	Heating voltage	5V±0.1	AC OR DC
R _L	Load resistance	can adjust	
R _H	Heater resistance	33 Ω ± 5%	Room Tem
P _H	Heating consumption	less than 800mw	

B. Environment condition

Symbol	Parameter name	Technical condition	Remarks
Tao	Using Tem	-20℃-50℃	
Tas	Storage Tem	-20℃-70℃	
R _H	Related humidity	less than 95%Rh	
O ₂	Oxygen concentration	21%(standard condition)Oxygen concentration can affect sensitivity	minimum value is over 2%

C. Sensitivity characteristic

Symbol	Parameter name	Technical parameter	Remarks
R _s	Sensing Resistance	3K Ω -30K Ω (1000ppm iso-butane)	Detecting concentration scope: 200ppm-5000ppm LPG and propane 300ppm-5000ppm butane
α (3000/1000) isobutane	Concentration Slope rate	≤0.6	
Standard Detecting Condition	Temp: 20℃ ± 2℃ Humidity: 65%±5%	V _c :5V±0.1 V _H : 5V±0.1	5000ppm-20000ppm methane 300ppm-5000ppm H ₂
Preheat time	Over 24 hour		100ppm-2000ppm Alcohol

D. Structure and configuration, basic measuring circuit

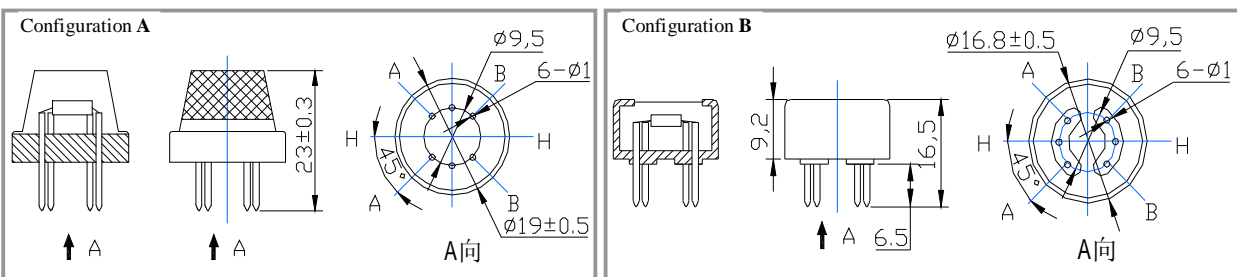
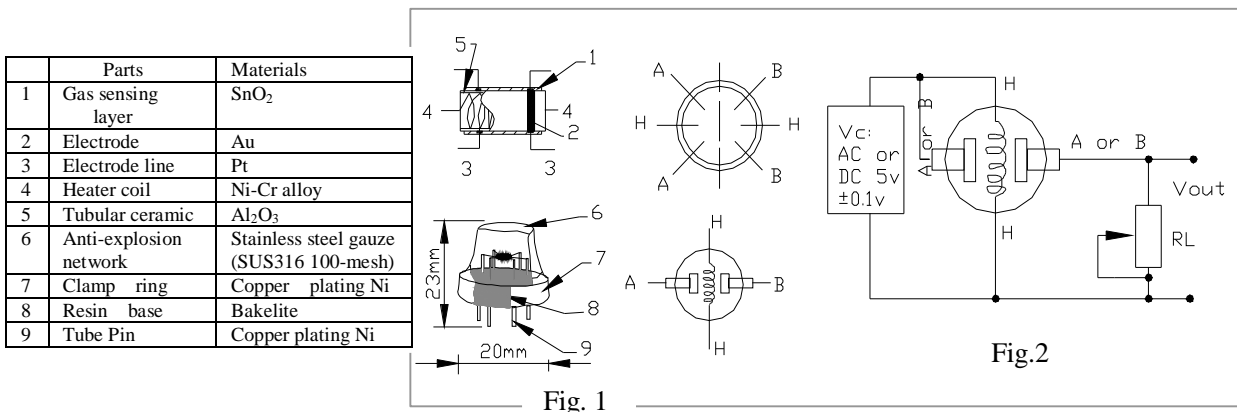

Structure and configuration of MQ-2 gas sensor is shown as Fig. 1 (Configuration A or B), sensor composed by micro AL₂O₃ ceramic tube, Tin Dioxide (SnO₂) sensitive layer, measuring electrode and heater are fixed into a

crust made by plastic and stainless steel net. The heater provides necessary work conditions for work of sensitive components. The enveloped MQ-2 have 6 pin ,4 of them are used to fetch signals, and other 2 are used for providing heating current.

Electric parameter measurement circuit is shown as Fig.2

E. Sensitivity characteristic curve

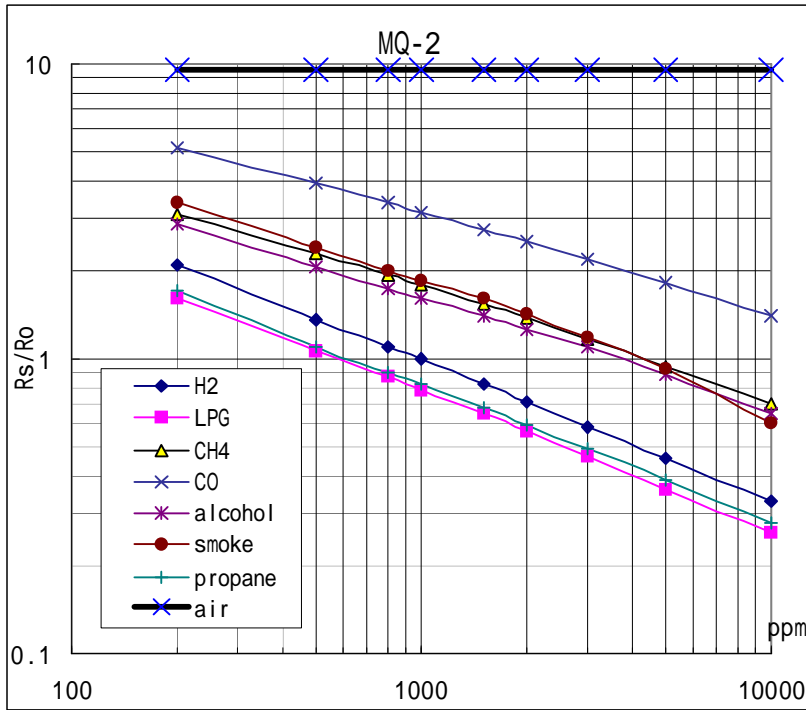

Fig.2 sensitivity characteristics of the MQ-2

Fig.3 is shows the typical sensitivity characteristics of the MQ-2 for several gases.

in their: Temp: 20°C、
Humidity: 65%、
O₂ concentration 21%
RL=5k Ω

Ro: sensor resistance at 1000ppm of H₂ in the clean air.
Rs:sensor resistance at various concentrations of gases.

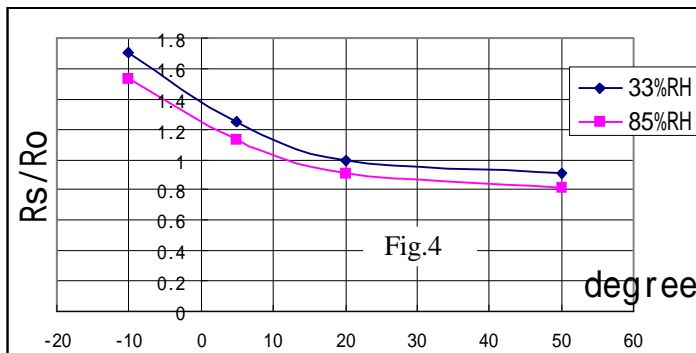

Fig.4 is shows the typical dependence of the MQ-2 on temperature and humidity.

Ro: sensor resistance at 1000ppm of H₂ in air at 33%RH and 20 degree.

Rs: sensor resistance at 1000ppm of H₂ at different temperatures and humidities.

SENSITIVITY ADJUSTMENT

Resistance value of MQ-2 is difference to various kinds and various concentration gases. So,When using this components, sensitivity adjustment is very necessary. we recommend that you calibrate the detector for 1000ppm liquified petroleum gas<LPG>,or 1000ppm iso-butane<i-C₄H₁₀>concentration in air and use value of Load resistance that(R_L) about 20 K Ω (5K Ω to 47 K Ω).

When accurately measuring, the proper alarm point for the gas detector should be determined after considering the temperature and humidity influence.