



Off-line Power Supply Controller

FEATURES

- Transformerless Off-line Applications
- Ideal Primary-side Bias Supply
- Efficient BiCMOS Design
- Wide Input Range
- Fixed or Adjustable Low Voltage Output
- Uses Low Cost SMD Inductors
- Short Circuit Protected
- Optional Isolation Capability

DESCRIPTION

The UCC1889 controller is optimized for use as an off-line, low power, low voltage, regulated bias supply. The unique circuit topology utilized in this device can be visualized as two cascaded flyback converters, each operating in the discontinuous mode, and both driven from a single external power switch. The significant benefit of this approach is the ability to achieve voltage conversion ratios of 400V to 12V with no transformer and low internal losses.

The control algorithm utilized by the UCC1889 is to force the switch on time to be inversely proportional to the input line voltage while the switch off time is made inversely proportional to the output voltage. This action is automatically controlled by an internal feedback loop and reference. The cascaded configuration allows a voltage conversion from 400V to 12V to be achieved with a switch duty cycle greater than 10%. This topology also offers inherent short circuit protection since as the output voltage falls to zero, the switch off time approaches infinity.

The output voltage can be easily set to 12V or 18V. Moreover, it can be programmed for other output voltages less than 18V with a few additional components. An isolated version can be achieved with this topology as described further in Unitrode Application Note U-149.

OPERATION

With reference to the application diagram below, when input voltage is first applied, the R_{ON} current into T_{ON} is directed to V_{CC} where it charges the external capacitor, C_3 , connected to V_{CC} . As voltage builds on V_{CC} , an internal undervoltage lockout holds the circuit off and the output at $DRIVE$ low until V_{CC} reaches 8.4V. At this time, $DRIVE$ goes high turning on the power switch, Q_1 , and redirecting the current into T_{ON} to the timing capacitor, C_T . C_T charges to a fixed threshold with a current $I_{CHG} = 0.8 \cdot (V_{IN} - 4.5V) / R_{ON}$. Since $DRIVE$ will only be high for as long as C_T charges, the power switch on time will be inversely proportional to line voltage. This provides a constant line voltage-switch on time product.

TYPICAL APPLICATION

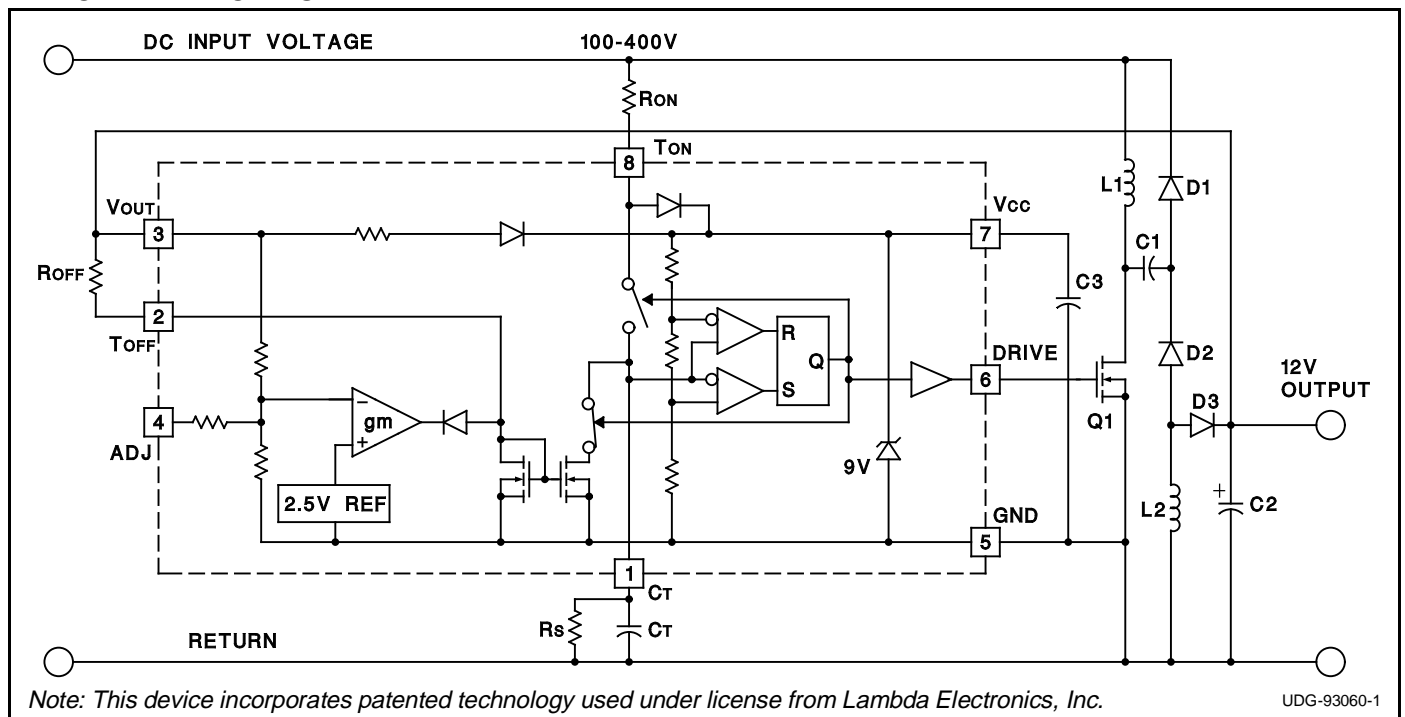

OPERATION (cont.)

At the end of the on time, Q1 is turned off and the RON current into TON is again diverted to VCC. Thus the current through RON, which charges CT during the on time, contributes to supplying control power during the off time.

The power switch off time is controlled by the discharge of CT which, in turn, is programmed by the regulated output voltage. The relationship between CT discharge current, IDCHG, and output voltage is illustrated as follows:

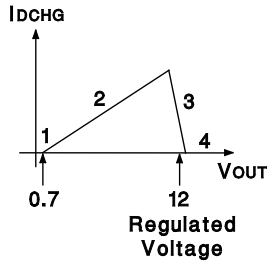

1. When VOUT = 0, the off time is infinite. This feature provides inherent short circuit protection. However, to ensure output voltage startup when the output is not a short, a high value resistor, RS, is placed in parallel with CT to establish a minimum switching frequency.
2. As VOUT rises above approximately 0.7V to its regulated value, IDCHG is defined by ROFF, and therefore is equal to:

$$IDCHG = (VOUT - 0.7V) / ROFF$$

As VOUT increases, IDCHG increases resulting in the reduction of off time. The frequency of operation increases and VOUT rises quickly to its regulated value.

3. In this region, a transconductance amplifier reduces IDCHG in order to maintain VOUT in regulation.
4. If VOUT should rise above its regulation range, IDCHG falls to zero and the circuit returns to the minimum frequency established by RS and CT.

The range of switching frequencies is established by RON, ROFF, RS, and CT as follows:

$$\text{Frequency} = 1 / (TON + TOFF)$$

$$TON = RON \cdot CT \cdot 4.6 V / (VIN - 4.5V)$$

$$TOFF (\text{max}) = 1.4 \cdot RS \cdot CT$$

Regions 1 and 4

$$TOFF = ROFF \cdot CT \cdot 3.7V / (VOUT - 0.7V)$$

Region 2, excluding the effects of RS

which have a minimal impact on TOFF.

The above equations assume that VCC equals 9V. The voltage at TON increases from approximately 2.5V to 6.5V while CT is charging. To take this into account, VIN is adjusted by 4.5V in the calculation of TON. The voltage at TOFF is approximately 0.7V.

DESIGN EXAMPLE

The UCC3889 regulates a 12 volt, 1 Watt nonisolated DC output from AC inputs between 80 and 265 volts. In this example, the IC is programmed to deliver a maximum on time gate drive pulse width of 2.4 microseconds which occurs at 80 VAC. The corresponding switching frequency is approximately 100kHz at low line, and overall efficiency is approximately 50%. Additional design information is available in Unitrode Application Note U-149.

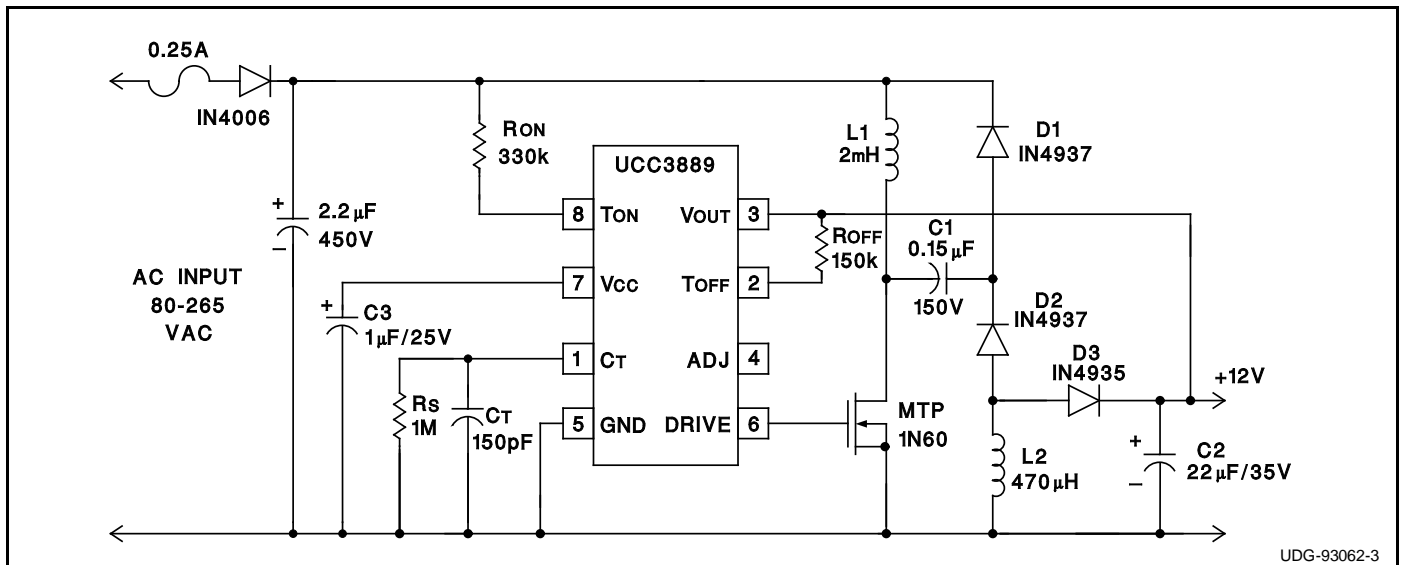

ABSOLUTE MAXIMUM RATINGS

| | |
|---|-----------------|
| I _{CC} | 5mA |
| Current into T _{ON} Pin | 1.5mA |
| Voltage on V _{OUT} Pin | 20V |
| Current into T _{OFF} Pin | 250μA |
| Storage Temperature | -65°C to +150°C |

Note: Unless otherwise indicated, voltages are referenced to ground and currents are positive into, negative out of, the specified terminals.

CONNECTION DIAGRAM

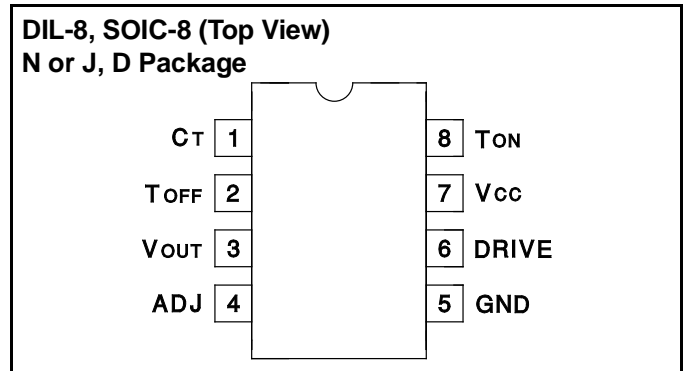

ELECTRICAL CHARACTERISTICS Unless otherwise stated, these specifications hold for T_A = 0°C to 70°C for the UCC3889, -40°C to +85°C for the UCC2889, and -55°C to +125°C for the UCC1889. No load at DRIVE pin (C_{LOAD}=0).

| PARAMETER | TEST CONDITIONS | MIN | TYP | MAX | UNITS |
|--|--|------|------|------|-------|
| General | | | | | |
| V _{CC} Zener Voltage | I _{CC} < 1.5mA | 8.6 | 9.0 | 9.3 | V |
| Startup Current | V _{OUT} = 0 | | 150 | 250 | μA |
| Operating Current I(V _{OUT}) | V _{OUT} = 11V, F = 150kHz | | 1.2 | 2.5 | mA |
| Under-Voltage-Lockout | | | | | |
| Start Threshold | V _{OUT} = 0 | 8.0 | 8.4 | 8.8 | V |
| Minimum Operating Voltage after Start | V _{OUT} = 0 | 6.0 | 6.3 | 6.6 | V |
| Hysteresis | V _{OUT} = 0 | 1.8 | | | V |
| Oscillator | | | | | |
| Amplitude | V _{CC} = 9V | 3.5 | 3.7 | 3.9 | V |
| C _T to DRIVE high Propagation Delay | Overdrive = 0.2V | | 100 | 200 | ns |
| C _T to DRIVE low Propagation Delay | Overdrive = 0.2V | | 50 | 100 | ns |
| Driver | | | | | |
| VOL | I = 20mA, V _{CC} = 9V | | 0.15 | 0.4 | V |
| | I = 100mA, V _{CC} = 9V | | 0.7 | 1.8 | V |
| VOH | I = -20mA, V _{CC} = 9V | 8.5 | 8.8 | | V |
| | I = -100mA, V _{CC} = 9V | 6.1 | 7.8 | | V |
| Rise Time | C _{LOAD} = 1nF | | 35 | 70 | ns |
| Fall Time | C _{LOAD} = 1nF | | 30 | 60 | ns |
| Line Voltage Detection | | | | | |
| Charge Coefficient: I _{CHG} / I(T _{ON}) | V _{CT} = 3V, DRIVE = High, I(T _{ON}) = 1mA | 0.73 | 0.79 | 0.85 | |
| Minimum Line Voltage for Fault | R _{ON} = 330k | 60 | 80 | 100 | V |
| Minimum Current I(T _{ON}) for Fault | R _{ON} = 330k | | 220 | | μA |
| On Time During Fault | C _T = 150pF, V _{LINE} = Min - 1V | | 2 | | μs |
| Oscillator Restart Delay after Fault | | | 0.5 | | ms |
| V_{OUT} Error Amp | | | | | |
| V _{OUT} Regulated 12V (ADJ Open) | V _{CC} = 9V, I _{DCHG} = I(T _{OFF})/2 | 11.2 | 11.9 | 12.8 | V |
| V _{OUT} Regulated 18V (ADJ = 0V) | V _{CC} = 9V, I _{DCHG} = I(T _{OFF})/2 | 16.5 | 17.5 | 19.5 | V |
| Discharge Ratio: I _{DCHG} / I(T _{OFF}) | I(T _{OFF}) = 50μA | 0.93 | 1.00 | 1.07 | |
| Voltage at T _{OFF} | I(T _{OFF}) = 50μA | 0.6 | 0.95 | 1.3 | V |
| Regulation gm (Note 1) | Max I _{DCHG} = 50μA | | 1.0 | | mA/V |
| | Max I _{DCHG} = 125μA | 0.8 | 1.7 | 2.9 | mA/V |

Note 1: gm is defined as $\frac{\Delta I_{DCHG}}{\Delta V_{OUT}}$ for the values of V_{OUT} when V_{OUT} is in regulation. The two points used to calculate gm are for I_{DCHG} at 65% and 35% of its maximum value.

PIN DESCRIPTIONS

ADJ: The ADJ pin is used to provide a 12V or an 18V regulated supply without additional external components. To select the 12V option, ADJ pin is left open. To select the 18V option, ADJ pin must be grounded. For other output voltages less than 18V, a resistor divider between VOUT, ADJ and GND is needed. Note, however, that for output voltages less than VCC, the device needs additional bootstrapping to VCC from an external source such as the line voltage. If so, precautions must be taken to ensure that total ICC does not exceed 5mA.

CT (timing capacitor): The signal voltage across CT has a peak-to-peak swing of 3.7V for 9V VCC. As the voltage on CT crosses the oscillator upper threshold, DRIVE goes low. As the voltage on CT crosses the oscillator lower threshold, DRIVE goes high.

DRIVE: This output is a CMOS stage capable of sinking 200mA peak and sourcing 150mA peak. The output voltage swing is 0 to VCC.

GND (chip ground): All voltages are measured with respect to GND.

TOFF (regulated output control): TOFF sets the discharge current of the timing capacitor through an external

resistor connected between VOUT and TOFF.

TON (line voltage control): TON serves three functions. When CT is discharging (off time), the current through TON is routed to VCC. When CT is charging (on time), the current through TON is split 80% to set the CT charge time and 20% to sense minimum line voltage which occurs for a TON current of 220µA. For a minimum line voltage of 80V, RON is 330kΩ.

The CT voltage slightly affects the value of the charge current during the on time. During this time, the voltage at the TON pin increases from approximately 2.5V to 6.5V.

VCC (chip supply voltage): The supply voltage of the device at pin VCC is internally clamped at 9V. Normally, VCC is not directly powered from an external voltage source such as the line voltage. In the event that VCC is directly connected to a voltage source for additional bootstrapping, precautions must be taken to ensure that total ICC does not exceed 5mA.

VOUT (regulated output): The VOUT pin is directly connected to the power supply output voltage. When VOUT is greater than VCC, VOUT bootstraps VCC.

BLOCK DIAGRAM

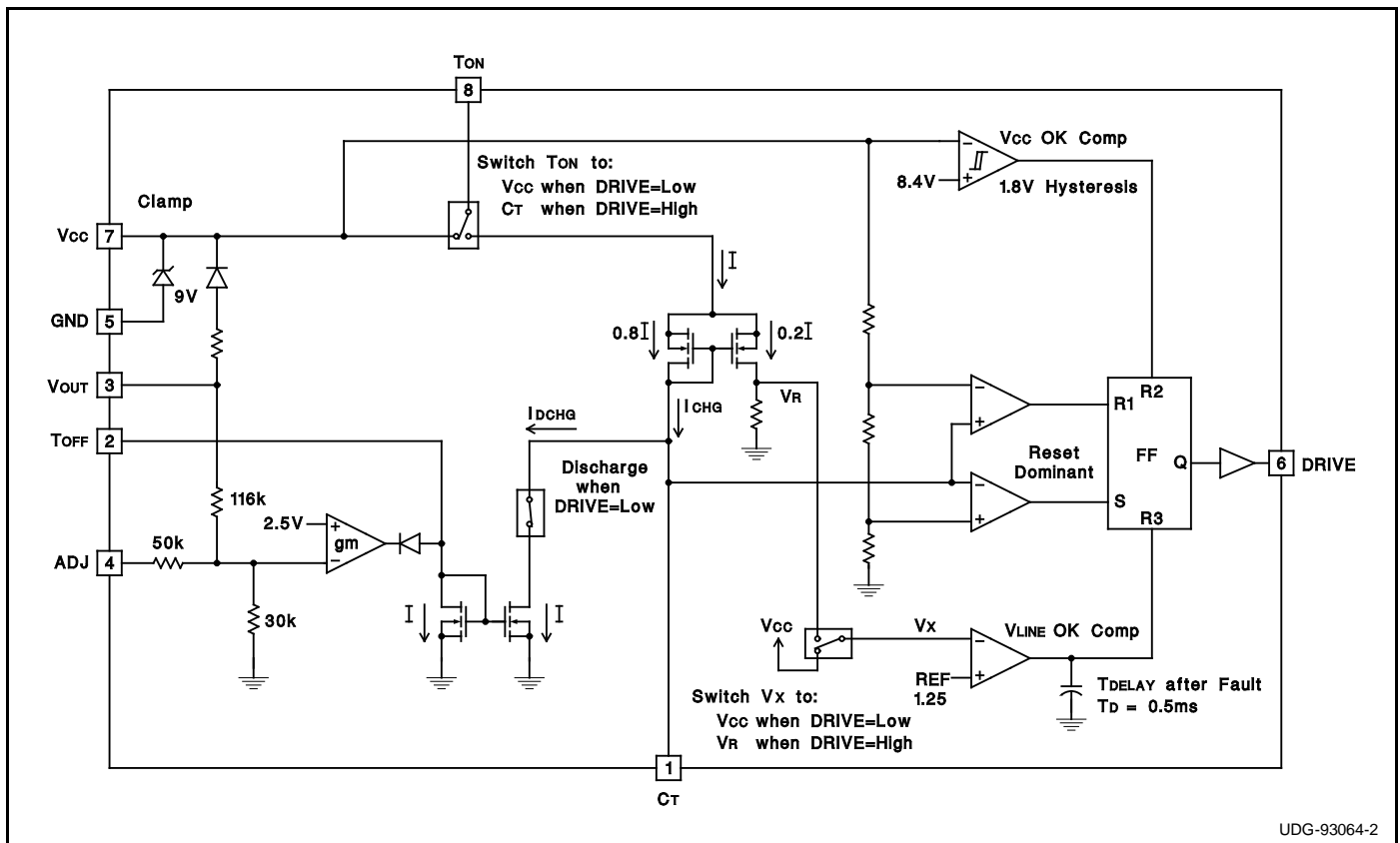

UDG-93064-2

TYPICAL WAVEFORMS

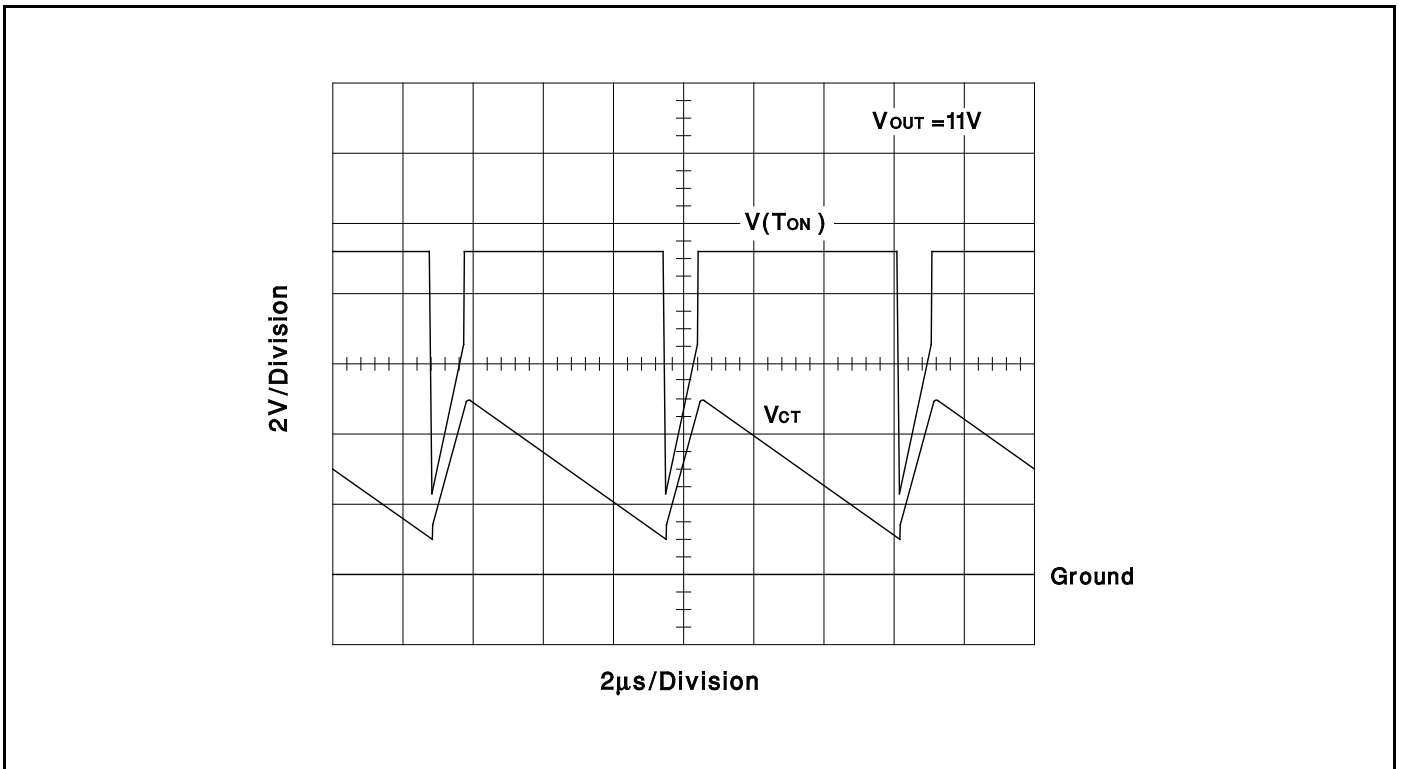
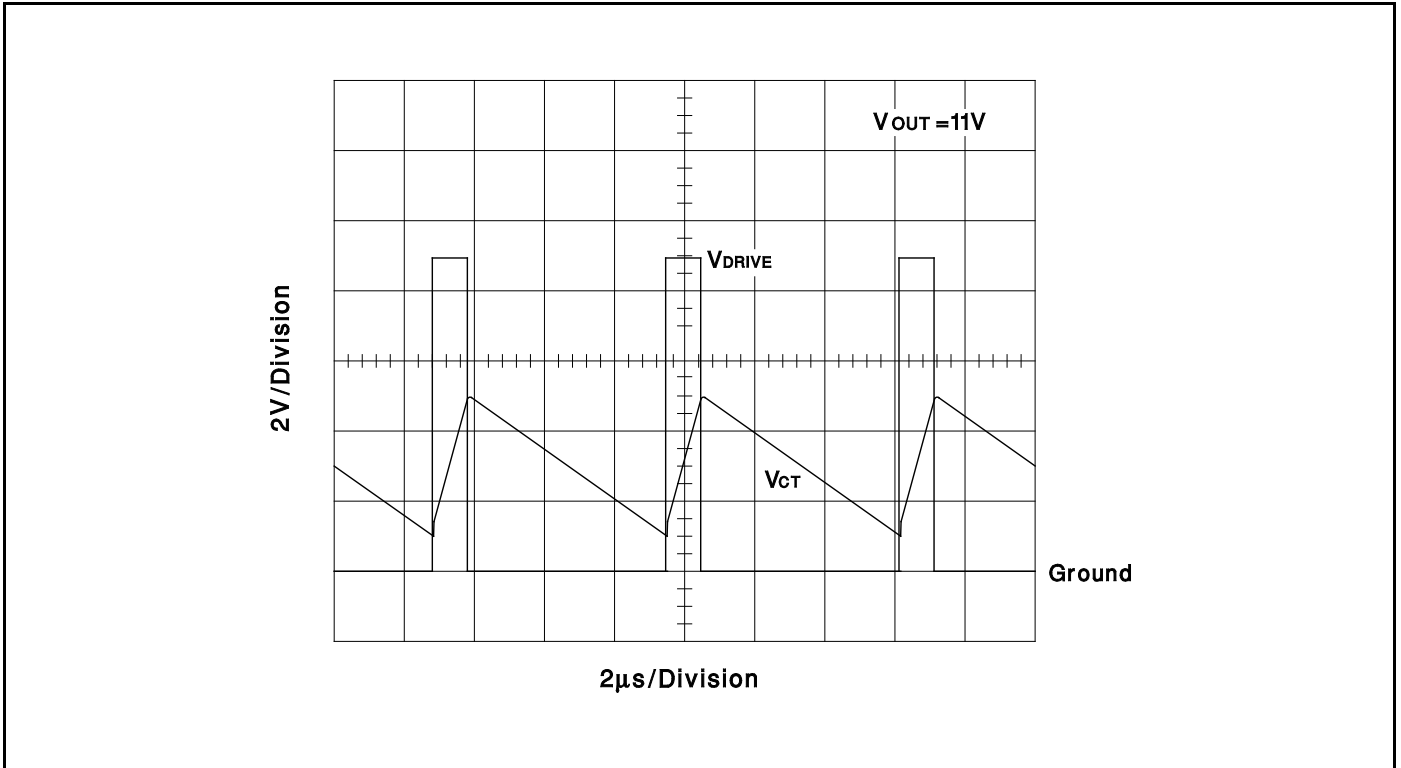

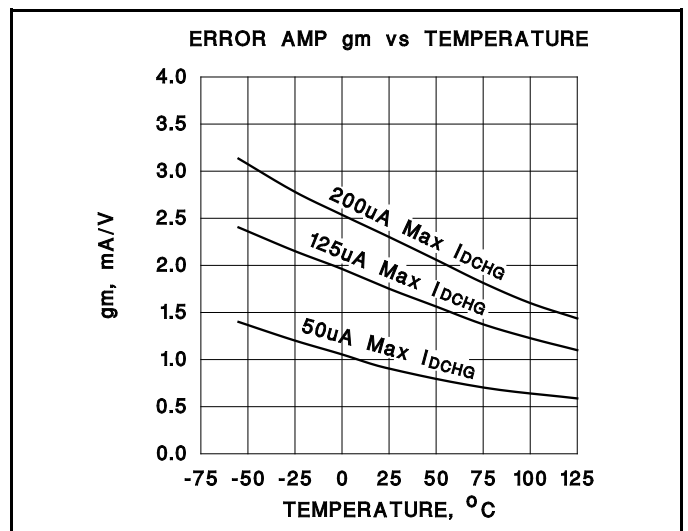
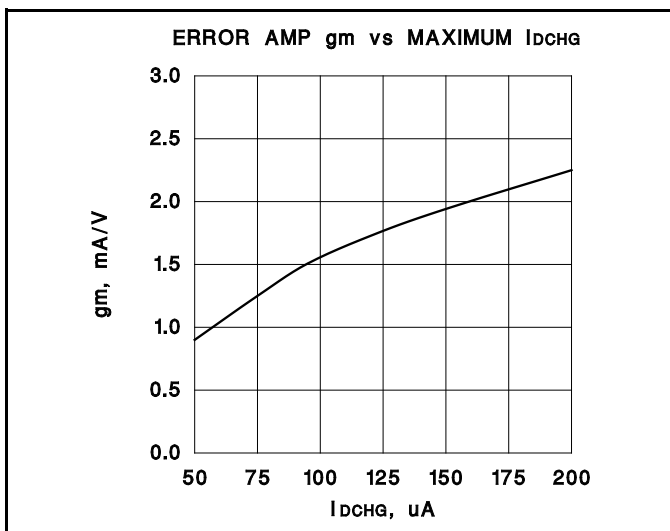
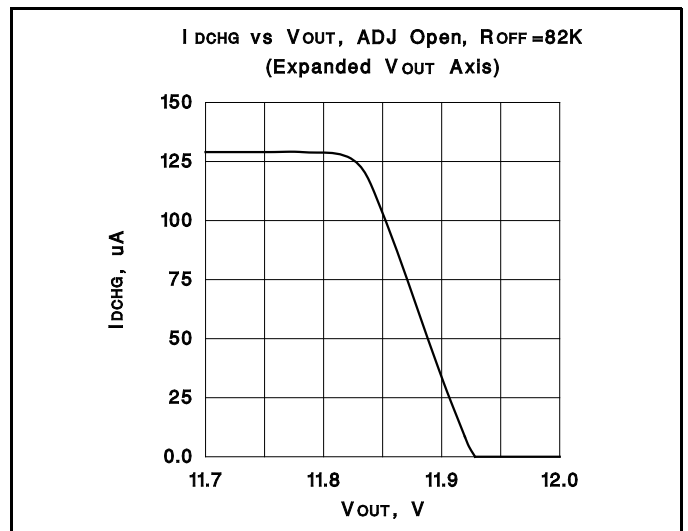
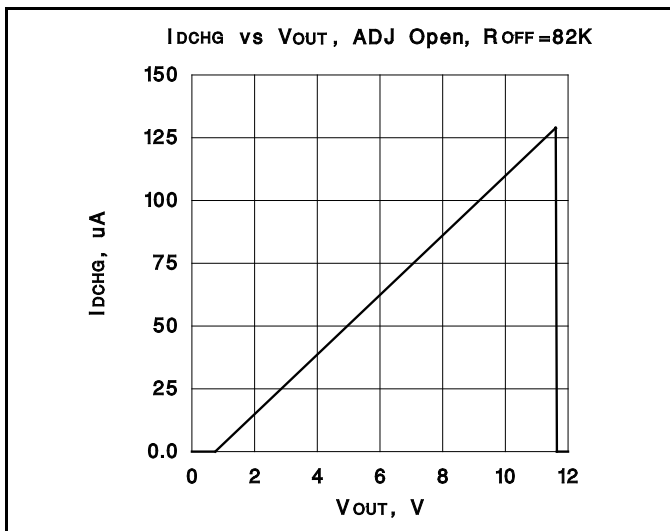
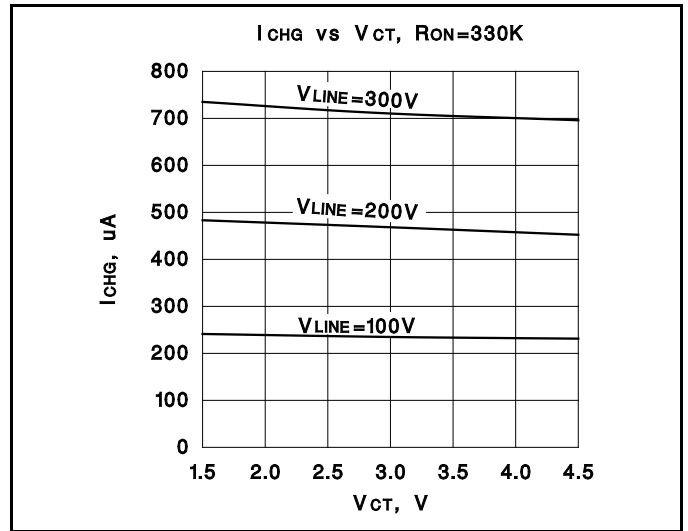
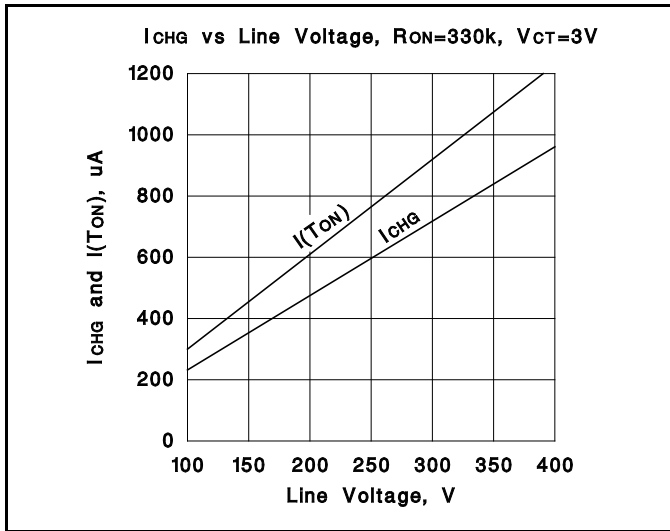

PACKAGING INFORMATION

| Orderable Device | Status (1) | Package Type | Package Drawing | Pins | Package Qty | Eco Plan (2) | Lead/Ball Finish (6) | MSL Peak Temp (3) | Op Temp (°C) | Device Marking (4/5) | Samples |
|------------------|---------------|--------------|-----------------|------|-------------|-------------------------|-------------------------|----------------------|--------------|-------------------------|-------------------------|
| UCC2889D | ACTIVE | SOIC | D | 8 | 75 | Green (RoHS & no Sb/Br) | CU NIPDAU | Level-2-260C-1 YEAR | -40 to 85 | UCC2889 | Samples |
| UCC2889DTR | ACTIVE | SOIC | D | 8 | 2500 | Green (RoHS & no Sb/Br) | CU NIPDAU | Level-2-260C-1 YEAR | -40 to 85 | UCC2889 | Samples |
| UCC2889DTRG4 | ACTIVE | SOIC | D | 8 | 2500 | Green (RoHS & no Sb/Br) | CU NIPDAU | Level-2-260C-1 YEAR | -40 to 85 | UCC2889 | Samples |
| UCC2889N | ACTIVE | PDIP | P | 8 | 50 | Green (RoHS & no Sb/Br) | CU NIPDAU | N / A for Pkg Type | -40 to 85 | UCC2889N | Samples |
| UCC3889D | ACTIVE | SOIC | D | 8 | 75 | Green (RoHS & no Sb/Br) | CU NIPDAU | Level-2-260C-1 YEAR | 0 to 70 | UCC3889 | Samples |
| UCC3889DG4 | ACTIVE | SOIC | D | 8 | 75 | Green (RoHS & no Sb/Br) | CU NIPDAU | Level-2-260C-1 YEAR | 0 to 70 | UCC3889 | Samples |
| UCC3889DTR | ACTIVE | SOIC | D | 8 | 2500 | Green (RoHS & no Sb/Br) | CU NIPDAU | Level-2-260C-1 YEAR | 0 to 70 | UCC3889 | Samples |
| UCC3889N | ACTIVE | PDIP | P | 8 | 50 | Green (RoHS & no Sb/Br) | CU NIPDAU | N / A for Pkg Type | 0 to 70 | UCC3889N | Samples |

(1) The marketing status values are defined as follows:

ACTIVE: Product device recommended for new designs.

LIFEBUY: TI has announced that the device will be discontinued, and a lifetime-buy period is in effect.

NRND: Not recommended for new designs. Device is in production to support existing customers, but TI does not recommend using this part in a new design.

PREVIEW: Device has been announced but is not in production. Samples may or may not be available.

OBSOLETE: TI has discontinued the production of the device.

(2) **RoHS:** TI defines "RoHS" to mean semiconductor products that are compliant with the current EU RoHS requirements for all 10 RoHS substances, including the requirement that RoHS substance do not exceed 0.1% by weight in homogeneous materials. Where designed to be soldered at high temperatures, "RoHS" products are suitable for use in specified lead-free processes. TI may reference these types of products as "Pb-Free".

RoHS Exempt: TI defines "RoHS Exempt" to mean products that contain lead but are compliant with EU RoHS pursuant to a specific EU RoHS exemption.

Green: TI defines "Green" to mean the content of Chlorine (Cl) and Bromine (Br) based flame retardants meet JS709B low halogen requirements of <=100ppm threshold. Antimony trioxide based flame retardants must also meet the <=1000ppm threshold requirement.

(3) MSL, Peak Temp. - The Moisture Sensitivity Level rating according to the JEDEC industry standard classifications, and peak solder temperature.

(4) There may be additional marking, which relates to the logo, the lot trace code information, or the environmental category on the device.

⁽⁵⁾ Multiple Device Markings will be inside parentheses. Only one Device Marking contained in parentheses and separated by a "-" will appear on a device. If a line is indented then it is a continuation of the previous line and the two combined represent the entire Device Marking for that device.

⁽⁶⁾ Lead/Ball Finish - Orderable Devices may have multiple material finish options. Finish options are separated by a vertical ruled line. Lead/Ball Finish values may wrap to two lines if the finish value exceeds the maximum column width.

Important Information and Disclaimer:The information provided on this page represents TI's knowledge and belief as of the date that it is provided. TI bases its knowledge and belief on information provided by third parties, and makes no representation or warranty as to the accuracy of such information. Efforts are underway to better integrate information from third parties. TI has taken and continues to take reasonable steps to provide representative and accurate information but may not have conducted destructive testing or chemical analysis on incoming materials and chemicals. TI and TI suppliers consider certain information to be proprietary, and thus CAS numbers and other limited information may not be available for release.

In no event shall TI's liability arising out of such information exceed the total purchase price of the TI part(s) at issue in this document sold by TI to Customer on an annual basis.

TAPE AND REEL INFORMATION

QUADRANT ASSIGNMENTS FOR PIN 1 ORIENTATION IN TAPE

*All dimensions are nominal

| Device | Package Type | Package Drawing | Pins | SPQ | Reel Diameter (mm) | Reel Width W1 (mm) | A0 (mm) | B0 (mm) | K0 (mm) | P1 (mm) | W (mm) | Pin1 Quadrant |
|------------|--------------|-----------------|------|------|--------------------|--------------------|---------|---------|---------|---------|--------|---------------|
| UCC2889DTR | SOIC | D | 8 | 2500 | 330.0 | 12.4 | 6.4 | 5.2 | 2.1 | 8.0 | 12.0 | Q1 |
| UCC3889DTR | SOIC | D | 8 | 2500 | 330.0 | 12.4 | 6.4 | 5.2 | 2.1 | 8.0 | 12.0 | Q1 |

TAPE AND REEL BOX DIMENSIONS

*All dimensions are nominal

| Device | Package Type | Package Drawing | Pins | SPQ | Length (mm) | Width (mm) | Height (mm) |
|------------|--------------|-----------------|------|------|-------------|------------|-------------|
| UCC2889DTR | SOIC | D | 8 | 2500 | 367.0 | 367.0 | 35.0 |
| UCC3889DTR | SOIC | D | 8 | 2500 | 367.0 | 367.0 | 35.0 |

D (R-PDSO-G8)

PLASTIC SMALL OUTLINE

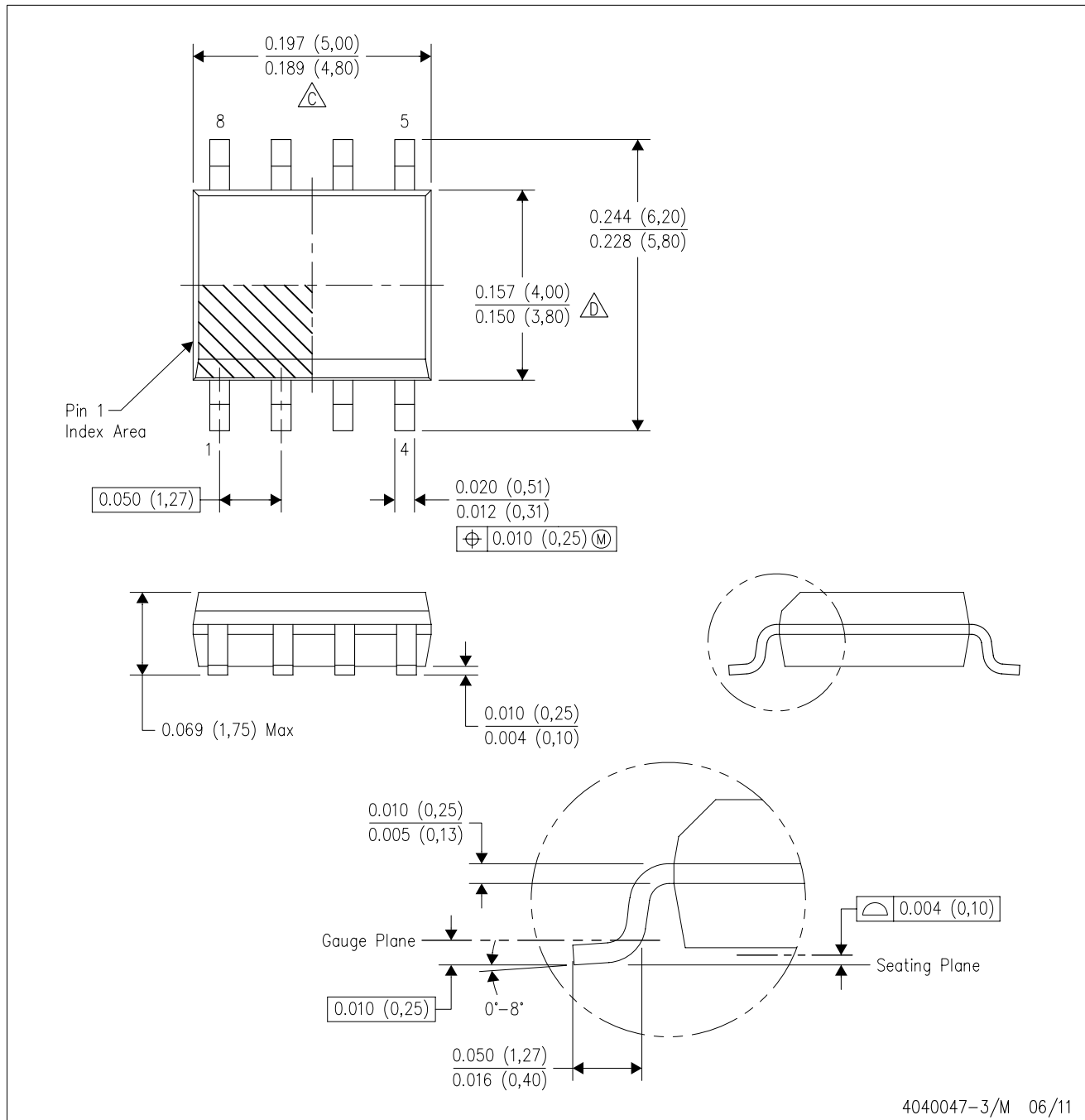

4040047-3/M 06/11

D (R-PDSO-G8)

PLASTIC SMALL OUTLINE



- NOTES:
- A. All linear dimensions are in millimeters.
 - B. This drawing is subject to change without notice.
 - C. Publication IPC-7351 is recommended for alternate designs.
 - D. Laser cutting apertures with trapezoidal walls and also rounding corners will offer better paste release. Customers should contact their board assembly site for stencil design recommendations. Refer to IPC-7525 for other stencil recommendations.
 - E. Customers should contact their board fabrication site for solder mask tolerances between and around signal pads.

P (R-PDIP-T8)

PLASTIC DUAL-IN-LINE PACKAGE



- NOTES:
- A. All linear dimensions are in inches (millimeters).
 - B. This drawing is subject to change without notice.
 - C. Falls within JEDEC MS-001 variation BA.

IMPORTANT NOTICE

Texas Instruments Incorporated (TI) reserves the right to make corrections, enhancements, improvements and other changes to its semiconductor products and services per JESD46, latest issue, and to discontinue any product or service per JESD48, latest issue. Buyers should obtain the latest relevant information before placing orders and should verify that such information is current and complete.

TI's published terms of sale for semiconductor products (<http://www.ti.com/sc/docs/stdterms.htm>) apply to the sale of packaged integrated circuit products that TI has qualified and released to market. Additional terms may apply to the use or sale of other types of TI products and services.

Reproduction of significant portions of TI information in TI data sheets is permissible only if reproduction is without alteration and is accompanied by all associated warranties, conditions, limitations, and notices. TI is not responsible or liable for such reproduced documentation. Information of third parties may be subject to additional restrictions. Resale of TI products or services with statements different from or beyond the parameters stated by TI for that product or service voids all express and any implied warranties for the associated TI product or service and is an unfair and deceptive business practice. TI is not responsible or liable for any such statements.

Buyers and others who are developing systems that incorporate TI products (collectively, "Designers") understand and agree that Designers remain responsible for using their independent analysis, evaluation and judgment in designing their applications and that Designers have full and exclusive responsibility to assure the safety of Designers' applications and compliance of their applications (and of all TI products used in or for Designers' applications) with all applicable regulations, laws and other applicable requirements. Designer represents that, with respect to their applications, Designer has all the necessary expertise to create and implement safeguards that (1) anticipate dangerous consequences of failures, (2) monitor failures and their consequences, and (3) lessen the likelihood of failures that might cause harm and take appropriate actions. Designer agrees that prior to using or distributing any applications that include TI products, Designer will thoroughly test such applications and the functionality of such TI products as used in such applications.

TI's provision of technical, application or other design advice, quality characterization, reliability data or other services or information, including, but not limited to, reference designs and materials relating to evaluation modules, (collectively, "TI Resources") are intended to assist designers who are developing applications that incorporate TI products; by downloading, accessing or using TI Resources in any way, Designer (individually or, if Designer is acting on behalf of a company, Designer's company) agrees to use any particular TI Resource solely for this purpose and subject to the terms of this Notice.

TI's provision of TI Resources does not expand or otherwise alter TI's applicable published warranties or warranty disclaimers for TI products, and no additional obligations or liabilities arise from TI providing such TI Resources. TI reserves the right to make corrections, enhancements, improvements and other changes to its TI Resources. TI has not conducted any testing other than that specifically described in the published documentation for a particular TI Resource.

Designer is authorized to use, copy and modify any individual TI Resource only in connection with the development of applications that include the TI product(s) identified in such TI Resource. NO OTHER LICENSE, EXPRESS OR IMPLIED, BY ESTOPPEL OR OTHERWISE TO ANY OTHER TI INTELLECTUAL PROPERTY RIGHT, AND NO LICENSE TO ANY TECHNOLOGY OR INTELLECTUAL PROPERTY RIGHT OF TI OR ANY THIRD PARTY IS GRANTED HEREIN, including but not limited to any patent right, copyright, mask work right, or other intellectual property right relating to any combination, machine, or process in which TI products or services are used. Information regarding or referencing third-party products or services does not constitute a license to use such products or services, or a warranty or endorsement thereof. Use of TI Resources may require a license from a third party under the patents or other intellectual property of the third party, or a license from TI under the patents or other intellectual property of TI.

TI RESOURCES ARE PROVIDED "AS IS" AND WITH ALL FAULTS. TI DISCLAIMS ALL OTHER WARRANTIES OR REPRESENTATIONS, EXPRESS OR IMPLIED, REGARDING RESOURCES OR USE THEREOF, INCLUDING BUT NOT LIMITED TO ACCURACY OR COMPLETENESS, TITLE, ANY EPIDEMIC FAILURE WARRANTY AND ANY IMPLIED WARRANTIES OF MERCHANTABILITY, FITNESS FOR A PARTICULAR PURPOSE, AND NON-INFRINGEMENT OF ANY THIRD PARTY INTELLECTUAL PROPERTY RIGHTS. TI SHALL NOT BE LIABLE FOR AND SHALL NOT DEFEND OR INDEMNIFY DESIGNER AGAINST ANY CLAIM, INCLUDING BUT NOT LIMITED TO ANY INFRINGEMENT CLAIM THAT RELATES TO OR IS BASED ON ANY COMBINATION OF PRODUCTS EVEN IF DESCRIBED IN TI RESOURCES OR OTHERWISE. IN NO EVENT SHALL TI BE LIABLE FOR ANY ACTUAL, DIRECT, SPECIAL, COLLATERAL, INDIRECT, PUNITIVE, INCIDENTAL, CONSEQUENTIAL OR EXEMPLARY DAMAGES IN CONNECTION WITH OR ARISING OUT OF TI RESOURCES OR USE THEREOF, AND REGARDLESS OF WHETHER TI HAS BEEN ADVISED OF THE POSSIBILITY OF SUCH DAMAGES.

Unless TI has explicitly designated an individual product as meeting the requirements of a particular industry standard (e.g., ISO/TS 16949 and ISO 26262), TI is not responsible for any failure to meet such industry standard requirements.

Where TI specifically promotes products as facilitating functional safety or as compliant with industry functional safety standards, such products are intended to help enable customers to design and create their own applications that meet applicable functional safety standards and requirements. Using products in an application does not by itself establish any safety features in the application. Designers must ensure compliance with safety-related requirements and standards applicable to their applications. Designer may not use any TI products in life-critical medical equipment unless authorized officers of the parties have executed a special contract specifically governing such use. Life-critical medical equipment is medical equipment where failure of such equipment would cause serious bodily injury or death (e.g., life support, pacemakers, defibrillators, heart pumps, neurostimulators, and implantables). Such equipment includes, without limitation, all medical devices identified by the U.S. Food and Drug Administration as Class III devices and equivalent classifications outside the U.S.

TI may expressly designate certain products as completing a particular qualification (e.g., Q100, Military Grade, or Enhanced Product). Designers agree that it has the necessary expertise to select the product with the appropriate qualification designation for their applications and that proper product selection is at Designers' own risk. Designers are solely responsible for compliance with all legal and regulatory requirements in connection with such selection.

Designer will fully indemnify TI and its representatives against any damages, costs, losses, and/or liabilities arising out of Designer's non-compliance with the terms and provisions of this Notice.