

## 8-BIT SINGLE-CHIP MICROCONTROLLER (WITH A/D CONVERTER)

The  $\mu$ PD78C14(A) is a single-chip, CMOS 8-bit microcontroller in which a 16-bit ALU, a ROM, a RAM, an A/D converter, a multifunction timer/event counter, and a serial interface are all integrated. Moreover, a 48-Kbyte external expansion memory (ROM/RAM) can be connected.

Since the  $\mu$ PD78C14(A) uses the CMOS construction, its operations are performed with low power consumption. By using the standby function, functions such as data retention are performed with lower power consumption.

**For details on functions, refer to the User's Manual listed below. Please read it before starting design work.**

**87AD series  $\mu$ PD78C18 User's Manual: IEU-1314**

## FEATURES

- High reliability as compared with  $\mu$ PD78C14
- 159 instructions: 87AD instruction set
  - Multiply and divide instructions, 16-bit arithmetic operation instructions
- Instruction cycle: 0.8  $\mu$ s at 15 MHz
- Internal ROM: 16384 W x 8
- Internal RAM: 256 W x 8
- Direct addressing to an external memory (ROM/RAM) up to 64 Kbytes
- Highly accurate 8-bit A/D converter: Eight analog inputs
- General-purpose serial interface: Asynchronous, synchronous, and I/O interface modes
- Multifunction 16-bit timer/event counter
- Two 8-bit timers
- I/O lines: 44
- Interrupt functions: Three external, eight internal
  - Non-maskable interrupt: 1
  - Maskable interrupts: 10
- Zero-cross detection function (two inputs)
- Standby functions: HALT mode, Hardware/software STOP mode

## ORDERING INFORMATION

Part number	Package	Quality grade
$\mu$ PD78C14G(A)-xxx-36	64-pin plastic QUIP	Special
$\mu$ PD78C14GF(A)-xxx-3BE	64-pin plastic QFP (14 x 20 mm)	Special
$\mu$ PD78C14L(A)-xxx	68-pin plastic QFJ (950 x 950 mil)	Special

**Remark** xxx is a ROM code suffix.

Please refer to "Quality grade on NEC Semiconductor Devices" (Document number IEI-1209) published by NEC Corporation to know the specification of quality grade on the devices and its recommended applications.

The information in this document is subject to change without notice.

Pin Configuration (Top View)

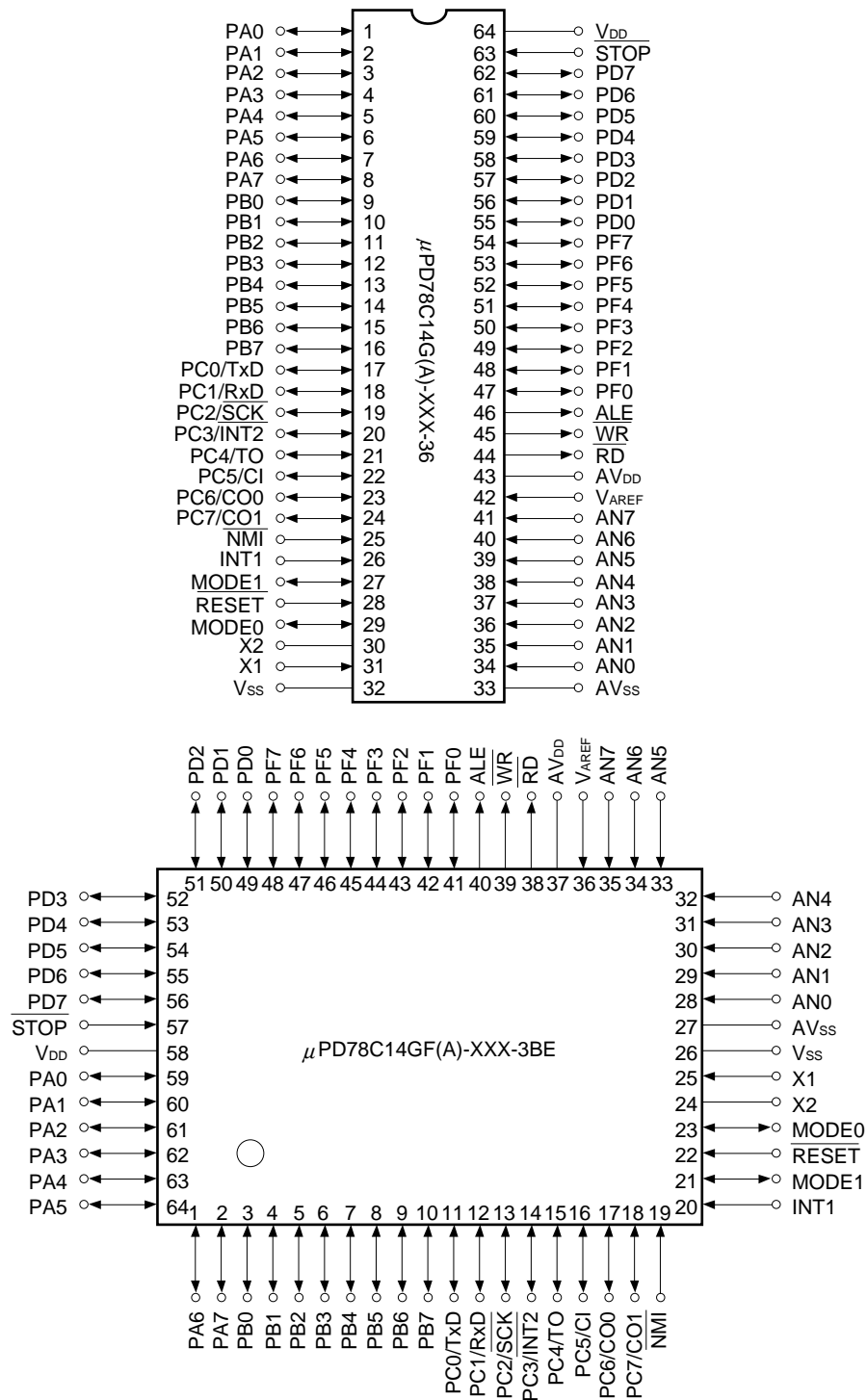

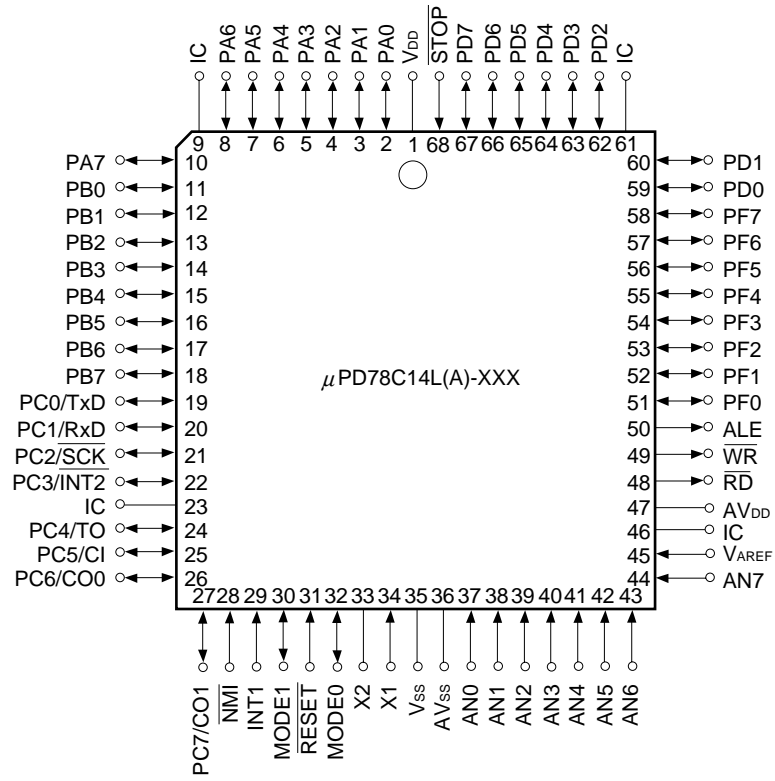

Block Diagram

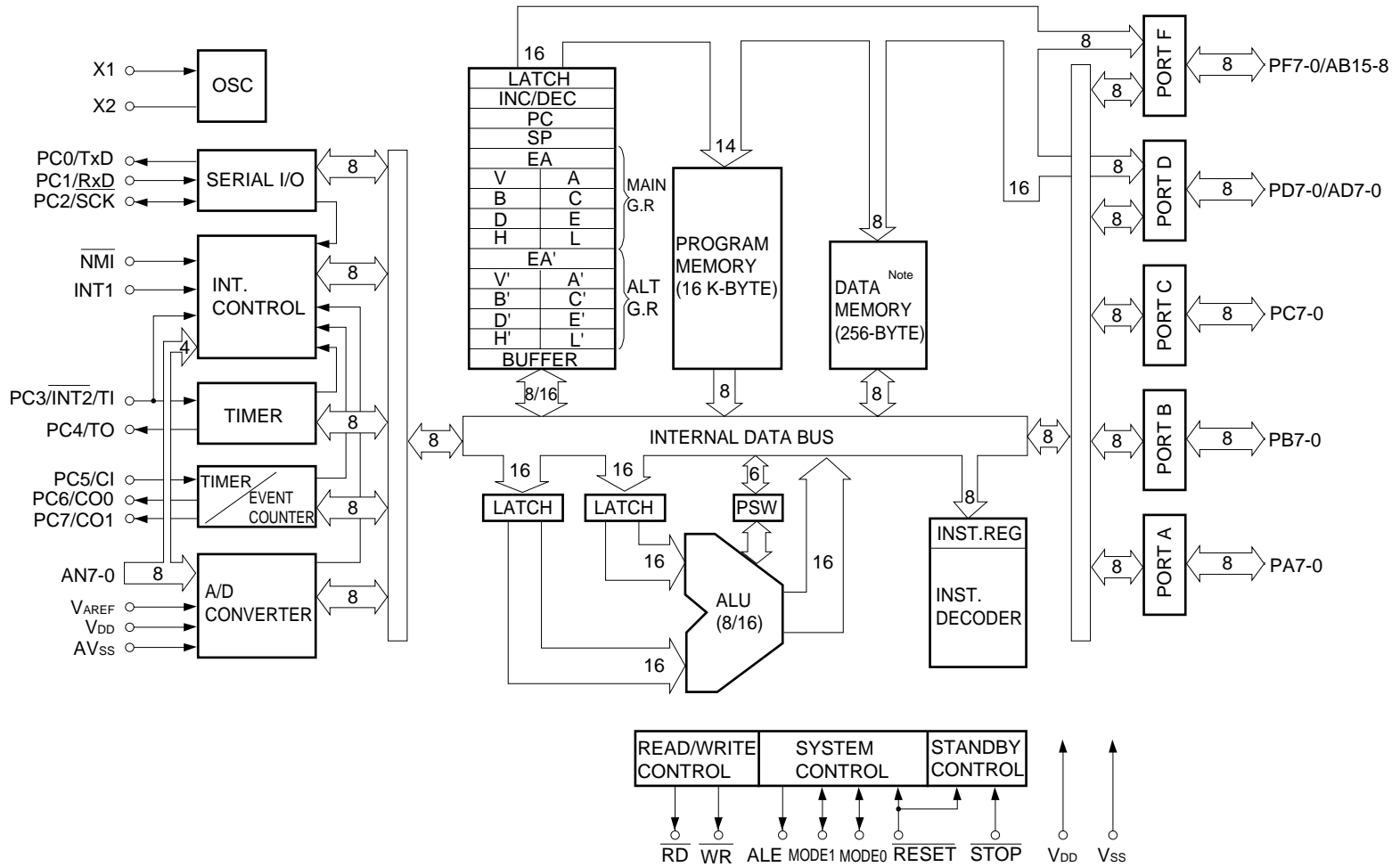

**Note** DATA MEMORY can only be used when RAE bit of MM register is set to 1. External memory is necessary when 0 is set.

**CONTENTS**

**1. DIFFERENCES BETWEEN μPD78C14(A) AND μPD78C14 .....6**

**2. PIN FUNCTIONS .....7**

**2.1 Pin Function List.....7**

**2.2 Pin Input/Output Circuits .....9**

**2.3 Recommended Connections for Unused Pins.....13**

**3. INSTRUCTION SET .....14**

**3.1 Operand Expression Format/Description Method .....14**

**3.2 Instruction Code Description .....16**

**3.3 Instruction Execution Time.....17**

**4. LIST OF MODE REGISTERS .....29**

**5. ELECTRICAL SPECIFICATIONS .....30**

**6. CHARACTERISTIC CURVES (reference value).....41**

**7. PACKAGE DRAWINGS .....44**

**8. RECOMMENDED SOLDERING CONDITIONS .....47**

**APPENDIX DEVELOPMENT TOOLS .....49**

1. DIFFERENCES BETWEEN μPD78C14(A) AND μPD78C14

Part number Item	μPD78C14(A)	μPD78C14
Quality grade	Special	Standard
Electrical specifications	Input leakage current (AN7-0; ±1 μA (MAX.))	Input leakage current AN7-0; ±10 μA (MAX.)
Package	<ul style="list-style-type: none"> <li>• 64-pin plastic QUIP</li> <li>• 64-pin plastic QFP (14 x 20 mm, thickness: 2.05 mm)</li> <li>• 68-pin plastic QFJ</li> </ul>	<ul style="list-style-type: none"> <li>• 64-pin plastic shrink DIP</li> <li>• 64-pin plastic QUIP</li> <li>• 64-pin plastic QUIP (straight)</li> <li>• 64-pin plastic QFP (14 x 20 mm, thickness: 2.05 mm)</li> <li>• 64-pin plastic QFP (14 x 20 mm, thickness: 2.70 mm)</li> <li>• 68-pin plastic QFJ</li> </ul>

2. PIN FUNCTIONS

2.1 Pin Function List

Pin	Input/Output	Function	
PA7-PA0 (Port A)	Input/Output	These 8 pins constitute an 8-bit I/O port and input/output can be specified in bit units.	
PB7-PB0 (Port B)	Input/Output	These 8 pins constitute an 8-bit I/O port and input/output can be specified in bit units.	
PC0/TxD	Input/Output, Output	Port C These 8 pins constitute an 8-bit I/O port and input/output can be specified in bit units.	Transmit Data This pin outputs serial data.
PC1/RxD	Input/Output, Input		Receive Data This pin inputs serial data.
PC2/SCK	Input/Output, Input/Output		Serial Clock This pin inputs/outputs serial clock. It becomes an output pin when an internal clock is used or an input pin when an external clock is used.
PC3/INT2/TI	Input/Output, Input, Input		Interrupt Request/Timer Input This pin inputs edge triggering (falling edge) maskable interrupt or external clock for timer. This pin is also shared with zero-cross detection pin for AC input.
PC4/TO	Input/Output, Output		Timer Output This pin outputs square waves in which one cycle of the internal clock forms a half cycle, indicating the timer's counting time.
PC5/CI	Input/Output, Input		Counter Input This pin inputs external pulse for timer/event counter.
PC6/CO0 PC7/CO1	Input/Output, Output		Counter Output 0,1 This pin outputs programmable square wave by timer/event counter.
PD7-PD0/ AD7-AD0	Input/Output, Input/Output	Port D These 8 pins constitute an 8-bit I/O port and input/output can be specified in byte units.	Address/Data Bus These pins function as multiplexed address/data bus when using an external memory.
PF7-PF0/ AB15-AB8	Input/Output, Output	Port F These 8 pins constitute an 8-bit I/O port and input/output can be specified in bit units.	Address Bus These pins function as address bus when using an external memory.
WR (Write Strobe)	Output	This is a strobe signal output to write data in external memory. This signal becomes high level except during the data write machine cycle for external memory. This signal becomes output high impedance when the $\overline{\text{RESET}}$ signal is low or in the hardware STOP mode.	

(Continued)

Pin	Input/Output	Function
$\overline{\text{RD}}$ (Read Strobe)	Output	This is a strobe signal output to read data from external memory. This signal becomes high level except during the data read machine cycle for external memory. This signal becomes output high impedance when the $\overline{\text{RESET}}$ signal is low or in the hardware STOP mode.
ALE (Address Latch Enable)	Output	This is a strobe signal to externally latch the low-order address information output to pins PD7-PD0 to access the external memory. This signal becomes output high impedance when the $\overline{\text{RESET}}$ signal is low or in the hardware STOP mode.
MODE0 MODE1 (Mode)	Input/Output	Set the MODE0 pin to 0 (low level) and MODE1 pin to 1 (high level) <sup>Note</sup> . When both pins MODE0 and MODE1 are set to 1 <sup>Note</sup> , these pins synchronize to the ALE and a control signal is output.
$\overline{\text{NMI}}$ (Non-Maskable Interrupt)	Input	This pin inputs the edge triggering (falling edge) nonmaskable interrupt.
INT1 (Interrupt Request)	Input	This pin inputs edge triggering (rising edge) maskable interrupt. This pin is also shared with zero-cross detection pin for AC input.
AN7-AN0 (Analog Input)	Input	These eight pins input analog signals for the A/D converter. Pins AN7-AN4 can be used as edge detection (falling edge) input.
$V_{\text{AREF}}$ (Reference Voltage)	Input	This pin inputs the reference voltage for the A/D converter and controls the operation for the A/D converter.
$A_{\text{VDD}}$ (Analog $V_{\text{DD}}$ )		Power supply pin for the A/D converter
$A_{\text{VSS}}$ (Analog $V_{\text{SS}}$ )		Ground pin for the A/D converter
X1, X2 (Crystal)		These are crystal connecting pins for the system clock oscillation. When a clock is externally supplied, input it through pin X1. Input the clock to X1 and its reverse phase to X2.
$\overline{\text{RESET}}$ (Reset)	Input	This pin inputs the active-low reset input signal.
$\overline{\text{STOP}}$ (Stop)	Input	This pin inputs control signal of the hardware STOP mode. When the low level of this signal is input, the oscillator stops to operate.
$V_{\text{DD}}$		Positive power supply pin
$V_{\text{SS}}$		Ground pin

**Note** Pull-up with the following external resistor:

$$4 \text{ (k}\Omega\text{)} \leq R \leq 0.4 t_{\text{CYC}} \text{ (k}\Omega\text{)} \quad t_{\text{CYC}} \text{ (unit: ns)}$$

Example  $4 \text{ (k}\Omega\text{)} \leq R \leq 26 \text{ (k}\Omega\text{)}$ :  $t_{\text{CYC}} = 66 \text{ (ns)}$  at 15 MHz

$4 \text{ (k}\Omega\text{)} \leq R \leq 33 \text{ (k}\Omega\text{)}$ :  $t_{\text{CYC}} = 83 \text{ (ns)}$  at 12 MHz



2.2 Pin Input/Output Circuits

Schematic input/output circuits of the pins are shown in Table 2-1 and figures from (1) to (11).

Table 2-1. Name of Type No.

Pin	Type No.	Pin	Type No.
PA0-7	5	RESET	2
PB0-7	5	$\overline{RD}$	4
PC0-1	5	$\overline{WR}$	4
PC2/SCK	8	ALE	4
PC3/ $\overline{INT2}$	10	$\overline{STOP}$	2
PC4-7	5	MODE0	11
PD0-7	5	MODE1	11
PF0-7	5	AN0-3	7
$\overline{NMI}$	2	AN4-7	12
INT1	9	V <sub>AREF</sub>	13

(1) Type 1

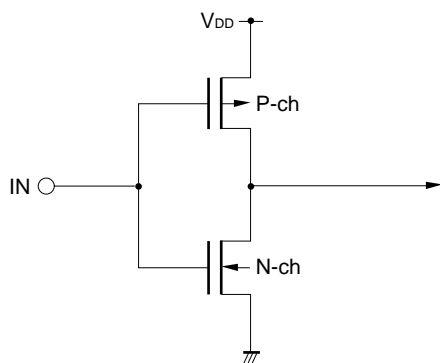

(2) Type 2

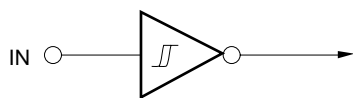

(3) Type 4

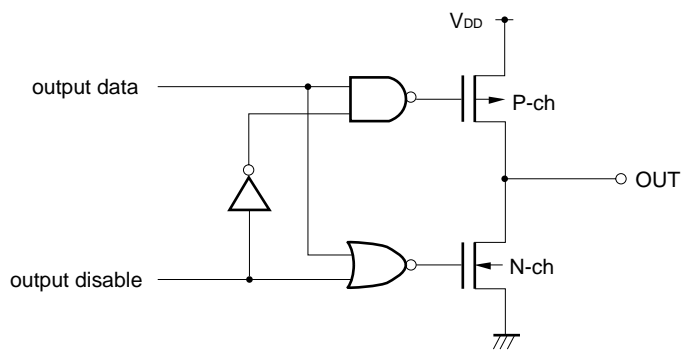

(4) Type 5

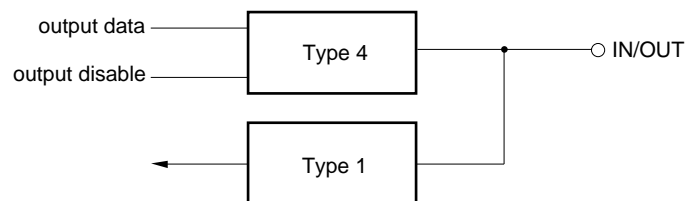

(5) Type 7

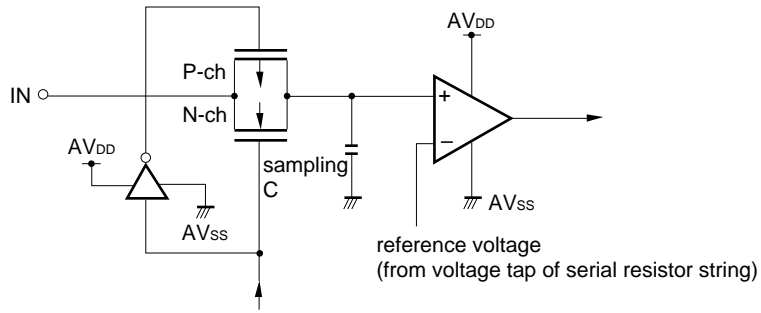

(6) Type 8

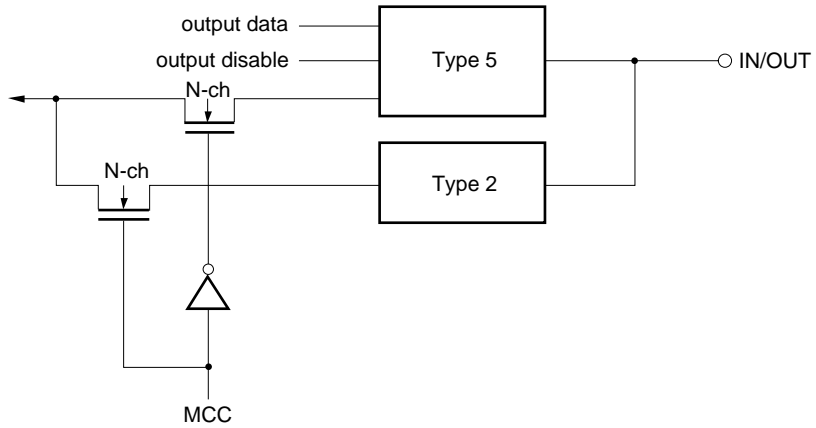

(7) Type 9

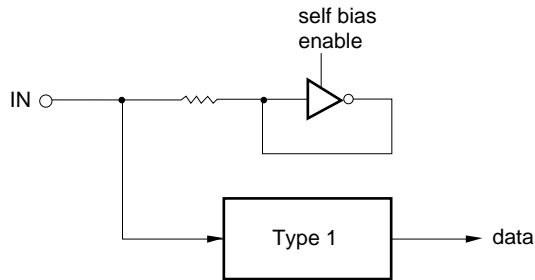

(8) Type 10

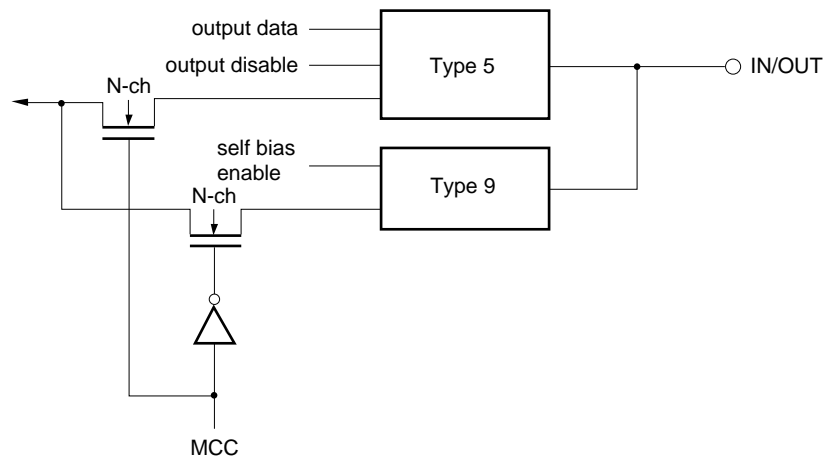

(9) Type 11

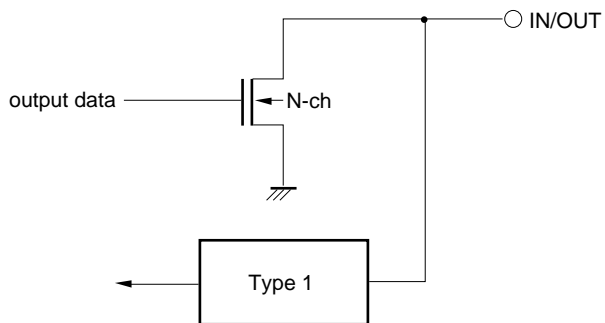

(10) Type 12

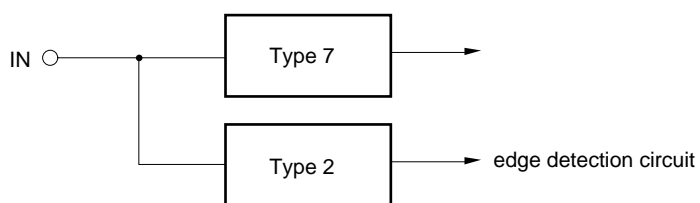

(11) Type 13

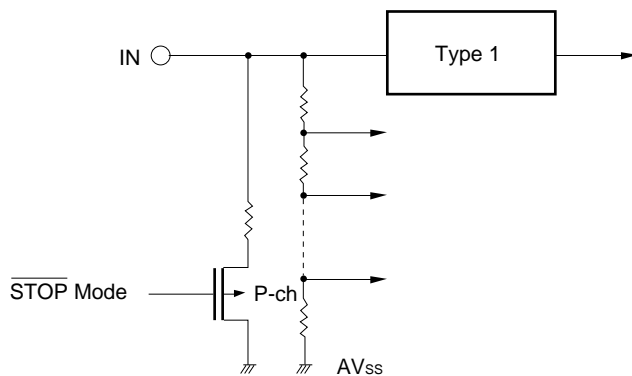

**2.3 Recommended Connections for Unused Pins**

Pin	Recommended connection
PA7-0 PB7-0 PC7-0 PD7-0 PF7-0	Connect to $V_{DD}$ or $V_{SS}$ via resistor.
$\overline{RD}$ $\overline{WR}$ ALE	Leave unconnected.
STOP	$V_{DD}$
INT1, $\overline{NMI}$	Connect to $V_{DD}$ or $V_{SS}$ .
$AV_{DD}$	Connect to $V_{DD}$ .
$V_{AREF}$ $AV_{SS}$	Connect to $V_{SS}$ .
AN7-0	Connect to $AV_{SS}$ or $AV_{DD}$ .

### 3. INSTRUCTION SET

#### 3.1 Operand Expression Format/Description Method

Expression format	Description method
r	V, A, B, C, D, E, H, L
r1	EAH, EAL, B, C, D, E, H, L
r2	A, B, C
sr	PA, PB, PC, PD, PF, MKH, MKL, ANM, SMH, SML, EOM, ETMM, TMM, MM, MCC, MA, MB, MC, MF, TXB, TM0, TM1, ZCM
sr1	PA, PB, PC, PD, PF, MKH, MKL, ANM, SMH, EOM, TMM, RXB, CR0, CR1, CR2, CR3
sr2	PA, PB, PC, PD, PF, MKH, MKL, ANM, SMH, EOM, TMM
sr3	ETM0, ETM1
sr4	ECNT, ECPT
rp	SP, B, D, H
rp1	V, B, D, H, EA
rp2	SP, B, D, H, EA
rp3	B, D, H
rpa	B, D, H, D+, H+, D-, H-
rpa1	B, D, H
rpa2	B, D, H, D+, H+, D-, H-, D+byte, H+A, H+B, H+EA, H+byte
rpa3	D, H, D++, H++, D+byte, H+A, H+B, H+EA, H+byte
wa	8-bit immediate data
word	16-bit immediate data
byte	8-bit immediate data
bit	3-bit immediate data
f	CY, HC, Z
irf	NMI <sup>Note</sup> , FT0, FT1, F1, F2, FE0, FE1, FEIN, FAD, FSR, FST, ER, OV, AN4, AN5, AN6, AN7, SB

**Note** NMI can be also described as FNMI.

**Remarks**

**1. sr to sr4 (special register)**

PA : PORT A	ETMM : TIMER/EVENT
PB : PORT B	COUNTER MODE
PC : PORT C	EOM : TIMER/EVENT
PD : PORT D	COUNTER OUTPUT
PF : PORT F	MODE
MA : MODE A	ANM : A/D CHANNEL MODE
MB : MODE B	CR0 : A/D CONVERSION
MC : MODE C	to RESULT 0 to 3
MCC : MODE CONTROL C	CR3
MF : MODE F	TXB : Tx BUFFER
MM : MEMORY MAPPING	RXB : Rx BUFFER
TM0 : TIMER REG0	SMH : SERIAL MODE High
TM1 : TIMER REG1	SML : SERIAL MODE Low
TMM : TIMER MODE	MKH : MASK High
ETM0 : TIMER/EVENT	MKL : MASK Low
COUNTER REG0	ZCM : ZERO CROSS MODE
ETM1 : TIMER/EVENT	
COUNTER REG1	
ECNT : TIMER/EVENT	
COUNTER UPCOUNTER	
ECPT : TIMER/EVENT	
COUNTER CAPTURE	

**2. rp to rp3 (register pair)**

SP : STACK POINTER
B : BC
D : DE
H : HL
V : VA
EA : EXTENDED
ACCUMULATOR

**4. f (flag)**

CY : CARRY
HC : HALF CARRY
Z : ZERO

**5. irf (interrupt flag)**

NMI : NMI INPUT
FT0 : INTFT0
FT1 : INTFT1
F1 : INTF1
F2 : INTF2
FE0 : INTFE0
FE1 : INTFE1
FEIN: INTFEIN
FAD : INTFAD
FSR : INTFSR
FST : INTFST
ER : ERROR
OV : OVERFLOW
AN4 : ANALOG INPUT
to 4 to 7
AN7
SB : STANDBY

**3. rpa to rpa3 (rp addressing)**

B : (BC)
D : (DE)
H : (HL)
D+ : (DE)+
H+ : (HL)+
D- : (DE)-
H- : (HL)-
D++ : (DE)++
H++ : (HL)++
D+byte: (DE+byte)
H+A : (HL+A)
H+B : (HL+B)
H+EA : (HL+EA)
H+byte: (HL+byte)

3.2 Instruction Code Description

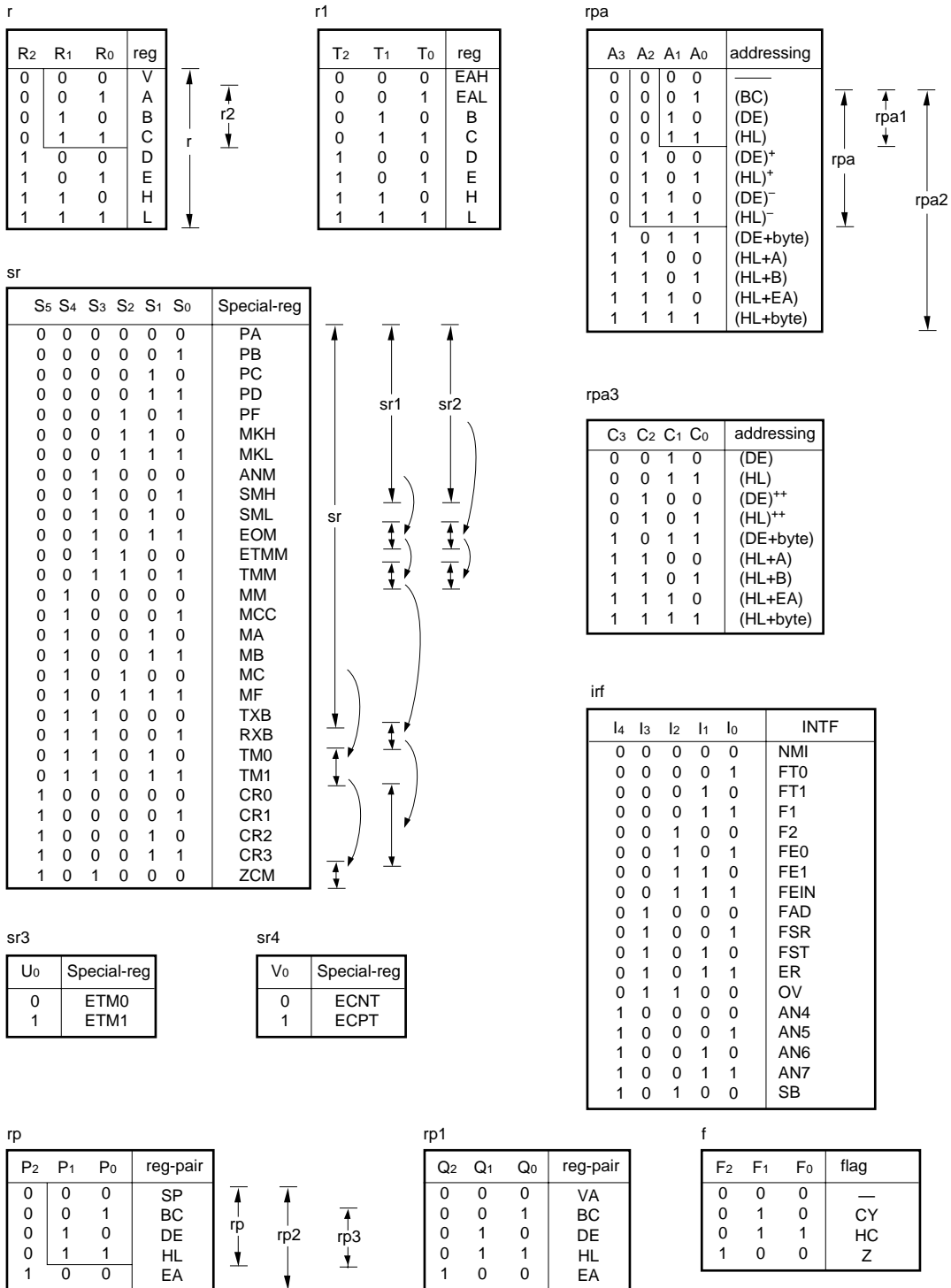



### 3.3 Instruction Execution Time

In the following table, one state consists of three clock cycles. So, when the 15 MHz clock is used, one state becomes 200 ns (=  $3 \times 1/15 \mu\text{s}$ ). Execution time of the 4-state instruction, the shortest instruction, becomes 0.8  $\mu\text{s}$ .

Instruc- tion group	Mnemonic	Operand	Instruction code				State	Operation	Skip condition
			B1	B2	B3	B4			
8-bit data transfer	MOV	r1, A	0 0 0 1 1 T <sub>2</sub> T <sub>1</sub> T <sub>0</sub>				4	r1 ← A	
		A, r1	0 0 0 0 1 T <sub>2</sub> T <sub>1</sub> T <sub>0</sub>				4	A ← r1	
		* sr, A	0 1 0 0 1 1 0 1	1 1 S <sub>5</sub> S <sub>4</sub> S <sub>3</sub> S <sub>2</sub> S <sub>1</sub> S <sub>0</sub>			10	sr ← A	
		* A, sr1	0 1 0 0 1 1 0 0	1 1 S <sub>5</sub> S <sub>4</sub> S <sub>3</sub> S <sub>2</sub> S <sub>1</sub> S <sub>0</sub>			10	A ← sr1	
		r, word	0 1 1 1 0 0 0 0	0 1 1 0 1 R <sub>2</sub> R <sub>1</sub> R <sub>0</sub>	Low Adrs	High Adrs	17	r ← (word)	
		word, r	0 1 1 1 0 0 0 0	0 1 1 1 1 R <sub>2</sub> R <sub>1</sub> R <sub>0</sub>	Low Adrs	High Adrs	17	(word) ← r	
	MVI	* r, byte	0 1 1 0 1 R <sub>2</sub> R <sub>1</sub> R <sub>0</sub>	← Data →			7	r ← byte	
		sr2, byte	0 1 1 0 0 1 0 0	S <sub>3</sub> 0 0 0 0 S <sub>2</sub> S <sub>1</sub> S <sub>0</sub>	Data		14	sr2 ← byte	
	MVIW	* wa, byte	0 1 1 1 0 0 0 1	← Offset →	Data		13	(V. wa) ← byte	
	MVIX	* rpa1, byte	0 1 0 0 1 0 A <sub>1</sub> A <sub>0</sub>	← Data →			10	(rpa1) ← byte	
	STAW	* wa	0 1 1 0 0 0 1 1	← Offset →			10	(V. wa) ← A	
	LDAW	* wa	0 0 0 0 0 0 0 1	← Offset →			10	A ← (V. wa)	
	STAX	* rpa2	A <sub>3</sub> 0 1 1 1 A <sub>2</sub> A <sub>1</sub> A <sub>0</sub>	Data <sup>Note 1</sup>			<sup>Note 3</sup> 7/13	(rpa2) ← A	
	LDAX	* rpa2	A <sub>3</sub> 0 1 0 1 A <sub>2</sub> A <sub>1</sub> A <sub>0</sub>	Data <sup>Note 1</sup>			<sup>Note 3</sup> 7/13	A ← (rpa2)	
	EXX		0 0 0 1 0 0 0 1				4	{ B ↔ B', C ↔ C', D ↔ D' E ↔ E', H ↔ H', L ↔ L' }	
	EXA		0 0 0 1 0 0 0 0				4	V, A ↔ V', A', EA ↔ EA'	
EXH		0 1 0 1 0 0 0 0				4	H, L ↔ H', L'		
BLOCK		0 0 1 1 0 0 0 1				13 (C+1)	(DE) <sup>+</sup> ← (HL) <sup>+</sup> , C ← C-1 End if borrow		
16-bit data transfer	DMOV	rp3, EA	1 0 1 1 0 1 P <sub>1</sub> P <sub>0</sub>				4	rp3 <sub>L</sub> ← EAL, rp3 <sub>H</sub> ← EAH	
		EA, rp3	1 0 1 0 0 1 P <sub>1</sub> P <sub>0</sub>				4	EAL ← rp3 <sub>L</sub> , EAH ← rp3 <sub>H</sub>	

Instruction group	Mnemonic	Operand	Instruction code				State	Operation	Skip condition
			B1	B2	B3	B4			
16-bit data transfer	DMOV	sr3, EA	0 1 0 0 1 0 0 0	1 1 0 1 0 0 1 U <sub>0</sub>			14	sr3 ← EA	
		EA, sr4	↓ ↓	1 1 0 0 0 0 0 V <sub>0</sub>			14	EA ← sr4	
	SBCD	word	0 1 1 1 0 0 0 0	0 0 0 1 1 1 1 0	Low Adrs	High Adrs	20	(word) ← C, (word+1) ← B	
	SDED	word	↓ ↓	0 0 1 0 1 1 1 0	↓	↓	20	(word) ← E, (word+1) ← D	
	SHLD	word	↓ ↓	0 0 1 1 1 1 1 0	↓	↓	20	(word) ← L, (word+1) ← H	
	SSPD	word	↓ ↓	0 0 0 0 1 1 1 0	↓	↓	20	(word) ← SP <sub>L</sub> , (word+1) ← SP <sub>H</sub>	
	STEAX	rpa3	0 1 0 0 1 0 0 0	1 0 0 1 C <sub>3</sub> C <sub>2</sub> C <sub>1</sub> C <sub>0</sub>	Data <sup>Note 2</sup>		Note 3 14/20	(rpa3) ← EAL, (rpa3+1) ← EAH	
	LBCD	word	0 1 1 1 0 0 0 0	0 0 0 1 1 1 1 1	Low Adrs	High Adrs	20	C ← (word), B ← (word+1)	
	LDED	word	↓ ↓	0 0 1 0 1 1 1 1	↓	↓	20	E ← (word), D ← (word+1)	
	LHLD	word	↓ ↓	0 0 1 1 1 1 1 1	↓	↓	20	L ← (word), H ← (word+1)	
	LSPD	word	↓ ↓	0 0 0 0 1 1 1 1	↓	↓	20	SP <sub>L</sub> ← (word), SP <sub>H</sub> ← (word+1)	
	LDEAX	rpa3	0 1 0 0 1 0 0 0	1 0 0 0 C <sub>3</sub> C <sub>2</sub> C <sub>1</sub> C <sub>0</sub>	Data <sup>Note 2</sup>		Note 3 14/20	EAL ← (rpa3), EAH ← (rpa3+1)	
	PUSH	rp1	1 0 1 1 0 Q <sub>2</sub> Q <sub>1</sub> Q <sub>0</sub>				13	(SP-1) ← rp1 <sub>H</sub> , (SP-2) ← rp1 <sub>L</sub> SP ← SP-2	
	POP	rp1	1 0 1 0 0 Q <sub>2</sub> Q <sub>1</sub> Q <sub>0</sub>				10	rp1 <sub>L</sub> ← (SP), rp1 <sub>H</sub> ← (SP+1) SP ← SP+2	
	LXI *	rp2, word	0 P <sub>2</sub> P <sub>1</sub> P <sub>0</sub> 0 1 0 0	← Low Byte →	High Byte		10	rp2 ← word	
TABLE		0 1 0 0 1 0 0 0	1 0 1 0 1 0 0 0			17	C ← (PC+3+A) B ← (PC+3+A+1)		
8-bit arithmetic operation (register)	ADD	A, r	0 1 1 0 0 0 0 0	1 1 0 0 0 R <sub>2</sub> R <sub>1</sub> R <sub>0</sub>			8	A ← A+r	
		r, A	↓ ↓	0 1 0 0	↓		8	r ← r+A	
	ADC	A, r	↓ ↓	1 1 0 1	↓		8	A ← A+r+CY	
		r, A	↓ ↓	0 1 0 1	↓		8	r ← r+A+CY	

Instruction group	Mnemonic	Operand	Instruction code				State	Operation	Skip condition								
			B1	B2	B3	B4											
8-bit arithmetic operation (register)	ADDNC	A, r	0	1	1	0	0	0	0	0	0	0	0	0	8	$A \leftarrow A+r$	No Carry
		r, A				0	0	1	0						8	$r \leftarrow r+A$	No Carry
	SUB	A, r				1	1	1	0						8	$A \leftarrow A-r$	
		r, A				0	1	1	0						8	$r \leftarrow r-A$	
	SBB	A, r				1	1	1	1						8	$A \leftarrow A-r-CY$	
		r, A				0	1	1	1						8	$r \leftarrow r-A-CY$	
	SUBNB	A, r				1	0	1	1						8	$A \leftarrow A-r$	No Borrow
		r, A				0	0	1	1						8	$r \leftarrow r-A$	No Borrow
	ANA	A, r				1	0	0	0	1	$R_2$	$R_1$	$R_0$		8	$A \leftarrow A \wedge r$	
		r, A				0	0	0	0						8	$r \leftarrow r \wedge A$	
	ORA	A, r				1	0	0	1						8	$A \leftarrow A \vee r$	
		r, A				0	0	0	1						8	$r \leftarrow r \vee A$	
	XRA	A, r				1	0	0	1	0	$R_2$	$R_1$	$R_0$		8	$A \leftarrow A \vee r$	
		r, A				0	0	0	1						8	$r \leftarrow r \vee A$	
	GTA	A, r				1	0	1	0	1	$R_2$	$R_1$	$R_0$		8	$A-r-1$	No Borrow
		r, A				0	0	1	0						8	$r-A-1$	No Borrow
	LTA	A, r				1	0	1	1						8	$A-r$	Borrow
		r, A				0	0	1	1						8	$r-A$	Borrow
	NEA	A, r				1	1	1	0						8	$A-r$	No Zero
		r, A				0	1	1	0						8	$r-A$	No Zero

Instruction group	Mnemonic	Operand	Instruction code				State	Operation	Skip condition
			B1	B2	B3	B4			
8-bit arithmetic operation (register)	EQA	A, r	0 1 1 0 0 0 0 0	1 1 1 1 1 R <sub>2</sub> R <sub>1</sub> R <sub>0</sub>			8	A←r	Zero
		r, A		0 1 1 1			8	r←A	Zero
	ONA	A, r		1 1 0 0			8	A∧r	No Zero
	OFFA	A, r		1 1 0 1			8	A∧r	Zero
8-bit arithmetic operation (memory)	ADDX	rpa	0 1 1 1 0 0 0 0	1 1 0 0 0 A <sub>2</sub> A <sub>1</sub> A <sub>0</sub>			11	A ← A+(rpa)	
	ADCX	rpa		1 1 0 1			11	A ← A+(rpa)+CY	
	ADDNCX	rpa		1 0 1 0			11	A ← A+(rpa)	No Carry
	SUBX	rpa		1 1 1 0			11	A ← A-(rpa)	
	SBBX	rpa		1 1 1 1			11	A ← A-(rpa)-CY	
	SUBNBX	rpa		1 0 1 1			11	A ← A-(rpa)	No Borrow
	ANAX	rpa		1 0 0 0 1 A <sub>2</sub> A <sub>1</sub> A <sub>0</sub>			11	A ← A∧(rpa)	
	ORAX	rpa		1 0 0 1			11	A ← A∨(rpa)	
	XRAX	rpa		1 0 0 1 0 A <sub>2</sub> A <sub>1</sub> A <sub>0</sub>			11	A ← A∨(rpa)	
	GTAX	rpa		1 0 1 0 1 A <sub>2</sub> A <sub>1</sub> A <sub>0</sub>			11	A-(rpa)-1	No Borrow
	LTAX	rpa		1 0 1 1			11	A-(rpa)	Borrow
	NEAX	rpa		1 1 1 0			11	A-(rpa)	No Zero
	EQAX	rpa		1 1 1 1			11	A-(rpa)	Zero
	ONAX	rpa		1 1 0 0			11	A∧(rpa)	No Zero
OFFAX	rpa		1 1 0 1			11	A∧(rpa)	Zero	

Instruction group	Mnemonic	Operand	Instruction code				State	Operation	Skip condition
			B1	B2	B3	B4			
Arithmetic operation of immediate data	ADI	* A, byte	0 1 0 0 0 1 1 0	← Data →			7	$A \leftarrow A + \text{byte}$	
		r, byte	0 1 1 1 0 1 0 0	0 1 0 0 0 R <sub>2</sub> R <sub>1</sub> R <sub>0</sub>	Data		11	$r \leftarrow r + \text{byte}$	
		sr2, byte	0 1 1 0 ↓	S <sub>3</sub> 1 0 0 0 S <sub>2</sub> S <sub>1</sub> S <sub>0</sub>	↓		20	$sr2 \leftarrow sr2 + \text{byte}$	
	ACI	* A, byte	0 1 0 1 0 1 1 0	← Data →			7	$A \leftarrow A + \text{byte} + CY$	
		r, byte	0 1 1 1 0 1 0 0	0 1 0 1 0 R <sub>2</sub> R <sub>1</sub> R <sub>0</sub>	Data		11	$r \leftarrow r + \text{byte} + CY$	
		sr2, byte	0 1 1 0 ↓	S <sub>3</sub> 1 0 1 0 S <sub>2</sub> S <sub>1</sub> S <sub>0</sub>	↓		20	$sr2 \leftarrow sr2 + \text{byte} + CY$	
	ADINC	* A, byte	0 0 1 0 0 1 1 0	← Data →			7	$A \leftarrow A + \text{byte}$	No Carry
		r, byte	0 1 1 1 0 1 0 0	0 0 1 0 0 R <sub>2</sub> R <sub>1</sub> R <sub>0</sub>	Data		11	$r \leftarrow r + \text{byte}$	No Carry
		sr2, byte	0 1 1 0 ↓	S <sub>3</sub> 0 1 0 0 S <sub>2</sub> S <sub>1</sub> S <sub>0</sub>	↓		20	$sr2 \leftarrow sr2 + \text{byte}$	No Carry
	SUI	* A, byte	0 1 1 0 0 1 1 0	← Data →			7	$A \leftarrow A - \text{byte}$	
		r, byte	0 1 1 1 0 1 0 0	0 1 1 0 0 R <sub>2</sub> R <sub>1</sub> R <sub>0</sub>	Data		11	$r \leftarrow r - \text{byte}$	
		sr2, byte	0 1 1 0 ↓	S <sub>3</sub> 1 1 0 0 S <sub>2</sub> S <sub>1</sub> S <sub>0</sub>	↓		20	$sr2 \leftarrow sr2 - \text{byte}$	
	SBI	* A, byte	0 1 1 1 0 1 1 0	← Data →			7	$A \leftarrow A - \text{byte} - CY$	
		r, byte	0 1 1 1 0 1 0 0	0 1 1 1 0 R <sub>2</sub> R <sub>1</sub> R <sub>0</sub>	Data		11	$r \leftarrow r - \text{byte} - CY$	
		sr2, byte	0 1 1 0 ↓	S <sub>3</sub> 1 1 1 0 S <sub>2</sub> S <sub>1</sub> S <sub>0</sub>	↓		20	$sr2 \leftarrow sr2 - \text{byte} - CY$	
	SUINB	* A, byte	0 0 1 1 0 1 1 0	← Data →			7	$A \leftarrow A - \text{byte}$	No Borrow
		r, byte	0 1 1 1 0 1 0 0	0 0 1 1 0 R <sub>2</sub> R <sub>1</sub> R <sub>0</sub>	Data		11	$r \leftarrow r - \text{byte}$	No Borrow
		sr2, byte	0 1 1 0 ↓	S <sub>3</sub> 0 1 1 0 S <sub>2</sub> S <sub>1</sub> S <sub>0</sub>	↓		20	$sr2 \leftarrow sr2 - \text{byte}$	No Borrow
ANI	* A, byte	0 0 0 0 0 1 1 1	← Data →			7	$A \leftarrow A \wedge \text{byte}$		
	r, byte	0 1 1 1 0 1 0 0	0 0 0 0 1 R <sub>2</sub> R <sub>1</sub> R <sub>0</sub>	Data		11	$r \leftarrow r \wedge \text{byte}$		

Instruc- tion group	Mnemonic	Operand	Instruction code				State	Operation	Skip condition
			B1	B2	B3	B4			
Arithmetic operation of immediate data	ANI	sr2, byte	0 1 1 0 0 1 0 0	S <sub>3</sub> 0 0 0 1 S <sub>2</sub> S <sub>1</sub> S <sub>0</sub>	Data		20	sr2 ← sr2 ∧ byte	
	*	A, byte	0 0 0 1 0 1 1 1	← Data →			7	A ← A ∨ byte	
	ORI	r, byte	0 1 1 1 0 1 0 0	0 0 0 1 1 R <sub>2</sub> R <sub>1</sub> R <sub>0</sub>	Data		11	r ← r ∨ byte	
		sr2, byte	0 1 1 0 ↓	S <sub>3</sub> 0 0 1 1 S <sub>2</sub> S <sub>1</sub> S <sub>0</sub>	↓		20	sr2 ← sr2 ∨ byte	
	*	A, byte	0 0 0 1 0 1 1 0	← Data →			7	A ← A ∨ byte	
		r, byte	0 1 1 1 0 1 0 0	0 0 0 1 0 R <sub>2</sub> R <sub>1</sub> R <sub>0</sub>	Data		11	r ← r ∨ byte	
	XRI	sr2, byte	0 1 1 0 ↓	S <sub>3</sub> 0 0 1 0 S <sub>2</sub> S <sub>1</sub> S <sub>0</sub>	↓		20	sr2 ← sr2 ∨ byte	
		*	A, byte	0 0 1 0 0 1 1 1	← Data →		7	A-byte-1	No Borrow
	GTI	r, byte	0 1 1 1 0 1 0 0	0 0 1 0 1 R <sub>2</sub> R <sub>1</sub> R <sub>0</sub>	Data		11	r-byte-1	No Borrow
		sr2, byte	0 1 1 0 ↓	S <sub>3</sub> 0 1 0 1 S <sub>2</sub> S <sub>1</sub> S <sub>0</sub>	↓		14	sr2-byte-1	No Borrow
	*	A, byte	0 0 1 1 0 1 1 1	← Data →			7	A-byte	Borrow
		r, byte	0 1 1 1 0 1 0 0	0 0 1 1 1 R <sub>2</sub> R <sub>1</sub> R <sub>0</sub>	Data		11	r-byte	Borrow
	LTI	sr2, byte	0 1 1 0 ↓	S <sub>3</sub> 0 1 1 1 S <sub>2</sub> S <sub>1</sub> S <sub>0</sub>	↓		14	sr2-byte	Borrow
		*	A, byte	0 1 1 0 0 1 1 1	← Data →		7	A-byte	No Zero
	NEI	r, byte	0 1 1 1 0 1 0 0	0 1 1 0 1 R <sub>2</sub> R <sub>1</sub> R <sub>0</sub>	Data		11	r-byte	No Zero
		sr2, byte	0 1 1 0 ↓	S <sub>3</sub> 1 1 0 1 S <sub>2</sub> S <sub>1</sub> S <sub>0</sub>	↓		14	sr2-byte	No Zero
	*	A, byte	0 1 1 1 0 1 1 1	← Data →			7	A-byte	Zero
		r, byte	0 1 1 1 0 1 0 0	0 1 1 1 1 R <sub>2</sub> R <sub>1</sub> R <sub>0</sub>	Data		11	r-byte	Zero
	EQI	sr2, byte	0 1 1 0 ↓	S <sub>3</sub> 1 1 1 1 S <sub>2</sub> S <sub>1</sub> S <sub>0</sub>	↓		14	sr2-byte	Zero

Instruc- tion group	Mnemonic	Operand	Instruction code				State	Operation	Skip condition	
			B1	B2	B3	B4				
Arithmetic operation of immediate data	ONI	* A, byte	0 1 0 0 0 1 1 1	← Data →				7	$A \wedge \text{byte}$	No Zero
		r, byte	0 1 1 1 0 1 0 0	0 1 0 0 1 R <sub>2</sub> R <sub>1</sub> R <sub>0</sub>	Data			11	$r \wedge \text{byte}$	No Zero
		sr2, byte	0 1 1 0	S <sub>3</sub> 1 0 0 1 S <sub>2</sub> S <sub>1</sub> S <sub>0</sub>	↓			14	$sr2 \wedge \text{byte}$	No Zero
	OFFI	* A, byte	0 1 0 1 0 1 1 1	← Data →				7	$A \wedge \text{byte}$	Zero
		r, byte	0 1 1 1 0 1 0 0	0 1 0 1 1 R <sub>2</sub> R <sub>1</sub> R <sub>0</sub>	Data			11	$r \wedge \text{byte}$	Zero
		sr2, byte	0 1 1 0	S <sub>3</sub> 1 0 1 1 S <sub>2</sub> S <sub>1</sub> S <sub>0</sub>	↓			14	$sr2 \wedge \text{byte}$	Zero
Arithmetic operation of working register	ADDW	wa	0 1 1 1 0 1 0 0	1 1 0 0 0 0 0 0	offset			14	$A \leftarrow A+(V.wa)$	
	ADCW	wa		1 1 0 1				14	$A \leftarrow A+(V.wa)+CY$	
	ADDNCW	wa		1 0 1 0				14	$A \leftarrow A+(V.wa)$	No Carry
	SUBW	wa		1 1 1 0				14	$A \leftarrow A-(V.wa)$	
	SBBW	wa		1 1 1 1				14	$A \leftarrow A-(V.wa)-CY$	
	SUBNBW	wa		1 0 1 1	↓			14	$A \leftarrow A-(V.wa)$	No Borrow
	ANAW	wa		1 0 0 0 1 0 0 0				14	$A \leftarrow A \wedge (V.wa)$	
	ORAW	wa		1 0 0 1	↓			14	$A \leftarrow A \vee (V.wa)$	
	XRAW	wa		1 0 0 1 0 0 0 0				14	$A \leftarrow A \oplus (V.wa)$	
	GTAW	wa		1 0 1 0 1 0 0 0				14	$A-(V.wa)-1$	No Borrow
	LTAW	wa		1 0 1 1				14	$A-(V.wa)$	Borrow
	NEAW	wa		1 1 1 0				14	$A-(V.wa)$	No Zero
	EQAW	wa		1 1 1 1				14	$A-(V.wa)$	Zero
ONAW	wa		1 1 0 0	↓			14	$A \wedge (V.wa)$	No Zero	



Instruction group	Mnemonic	Operand	Instruction code				State	Operation	Skip condition
			B1	B2	B3	B4			
Arithmetic operation of working register	OFFAW	wa	0 1 1 1 0 1 0 0	1 1 0 1 1 0 0 0	Offset		14	$A \wedge (V.wa)$	Zero
	ANIW *	wa, byte	0 0 0 0 0 1 0 1	← Offset →		Data	19	$(V.wa) \leftarrow (V.wa) \wedge \text{byte}$	
	ORIW *	wa, byte	0 0 0 1				19	$(V.wa) \leftarrow (V.wa) \vee \text{byte}$	
	GTIW *	wa, byte	0 0 1 0				13	$(V.wa) - \text{byte} - 1$	No Borrow
	LTIW *	wa, byte	0 0 1 1				13	$(V.wa) - \text{byte}$	Borrow
	NEIW *	wa, byte	0 1 1 0				13	$(V.wa) - \text{byte}$	No Zero
	EQIW *	wa, byte	0 1 1 1				13	$(V.wa) - \text{byte}$	Zero
	ONIW *	wa, byte	0 1 0 0				13	$(V.wa) \wedge \text{byte}$	No Zero
	OFFIW *	wa, byte	0 1 0 1				13	$(V.wa) \wedge \text{byte}$	Zero
	16-bit arithmetic operation	EADD	EA, r2	0 1 1 1 0 0 0 0	0 1 0 0 0 0 R <sub>1</sub> R <sub>0</sub>			11	$EA \leftarrow EA + r2$
DADD		EA, rp3		0 1 0 0	1 1 0 0 0 1 P <sub>1</sub> P <sub>0</sub>		11	$EA \leftarrow EA + rp3$	
DADC		EA, rp3			1 1 0 1		11	$EA \leftarrow EA + rp3 + CY$	
DADDNC		EA, rp3			1 0 1 0		11	$EA \leftarrow EA + rp3$	No Carry
ESUB		EA, r2		0 0 0 0	0 1 1 0 0 0 R <sub>1</sub> R <sub>0</sub>		11	$EA \leftarrow EA - r2$	
DSUB		EA, rp3		0 1 0 0	1 1 1 0 0 1 P <sub>1</sub> P <sub>0</sub>		11	$EA \leftarrow EA - rp3$	
DSBB		EA, rp3			1 1 1 1		11	$EA \leftarrow EA - rp3 - CY$	
DSUBNB		EA, rp3			1 0 1 1		11	$EA \leftarrow EA - rp3$	No Borrow
DAN		EA, rp3			1 0 0 0 1 1 P <sub>1</sub> P <sub>0</sub>		11	$EA \leftarrow EA \wedge rp3$	
DOR		EA, rp3			1 0 0 1		11	$EA \leftarrow EA \vee rp3$	
DXR		EA, rp3			1 0 0 1 0 1 P <sub>1</sub> P <sub>0</sub>		11	$EA \leftarrow EA \nabla rp3$	

Instruction group	Mnemonic	Operand	Instruction code				State	Operation	Skip condition
			B1	B2	B3	B4			
16-bit arithmetic operation	DGT	EA, rp3	0 1 1 1 0 1 0 0	1 0 1 0 1 1 P <sub>1</sub> P <sub>0</sub>			11	EA←rp3-1	No Borrow
	DLT	EA, rp3		1 0 1 1			11	EA←rp3	Borrow
	DNE	EA, rp3		1 1 1 0			11	EA←rp3	No Zero
	DEQ	EA, rp3		1 1 1 1			11	EA←rp3	Zero
	DON	EA, rp3		1 1 0 0			11	EA∧rp3	No Zero
	DOFF	EA, rp3		1 1 0 1			11	EA∧rp3	Zero
Multiply/divide	MUL	r2	0 1 0 0 1 0 0 0	0 0 1 0 1 1 R <sub>1</sub> R <sub>0</sub>			32	EA ← A×r2	
	DIV	r2		0 0 1 1			59	EA ← EA÷r2, r2 ← The Remainder	
Decrement/Increment	INR	r2	0 1 0 0 0 0 R <sub>1</sub> R <sub>0</sub>				4	r2 ← r2+1	Carry
	INRW	* wa	0 0 1 0 0 0 0 0	← Offset →			16	(V.wa) ← (V.wa)+1	Carry
	INX	rp	0 0 P <sub>1</sub> P <sub>0</sub> 0 0 1 0				7	rp ← rp+1	
		EA	1 0 1 0 1 0 0 0				7	EA ← EA+1	
	DCR	r2	0 1 0 1 0 0 R <sub>1</sub> R <sub>0</sub>				4	r2 ← r2-1	Borrow
	DCRW	* wa	0 0 1 1 0 0 0 0	← Offset →			16	(V.wa) ← (V.wa)-1	Borrow
DCX	rp	0 0 P <sub>1</sub> P <sub>0</sub> 0 0 1 1				7	rp ← rp-1		
	EA	1 0 1 0 1 0 0 1				7	EA ← EA-1		
Other arithmetic operation	DAA		0 1 1 0 0 0 0 1				4	Decimal Adjust Accumulator	
	STC		0 1 0 0 1 0 0 0	0 0 1 0 1 0 1 1			8	CY ← 1	
	CLC			0 0 1 0 1 0 1 0			8	CY ← 0	
	NEGA			0 0 1 1 1 0 1 0			8	A ← $\bar{A}$ +1	

Instruc- tion group	Mnemonic	Operand	Instruction code				State	Operation	Skip condition
			B1	B2	B3	B4			
Rotation shift	RLD		0 1 0 0 1 0 0 0	0 0 1 1 1 0 0 0			17	Rotate Left Digit	
	RRD			1 0 0 1			17	Rotate Right Digit	
	RLL	r2		0 1 R <sub>1</sub> R <sub>0</sub>			8	r <sub>2m+1</sub> ← r <sub>2m</sub> , r <sub>20</sub> ← CY, CY ← r <sub>27</sub>	
	RLR	r2		0 0 R <sub>1</sub> R <sub>0</sub>			8	r <sub>2m-1</sub> ← r <sub>2m</sub> , r <sub>27</sub> ← CY, CY ← r <sub>20</sub>	
	SLL	r2		0 0 1 0 0 1 R <sub>1</sub> R <sub>0</sub>			8	r <sub>2m+1</sub> ← r <sub>2m</sub> , r <sub>20</sub> ← 0, CY ← r <sub>27</sub>	
	SLR	r2		0 0 R <sub>1</sub> R <sub>0</sub>			8	r <sub>2m-1</sub> ← r <sub>2m</sub> , r <sub>27</sub> ← 0, CY ← r <sub>20</sub>	
	SLLC	r2		0 0 0 0 0 1 R <sub>1</sub> R <sub>0</sub>			8	r <sub>2m+1</sub> ← r <sub>2m</sub> , r <sub>20</sub> ← 0, CY ← r <sub>27</sub>	Carry
	SLRC	r2		0 0 R <sub>1</sub> R <sub>0</sub>			8	r <sub>2m-1</sub> ← r <sub>2m</sub> , r <sub>27</sub> ← 0, CY ← r <sub>20</sub>	Carry
	DRLL	EA		1 0 1 1 0 1 0 0			8	EA <sub>n+1</sub> ← EA <sub>n</sub> , EA <sub>0</sub> ← CY, CY ← EA <sub>15</sub>	
	DRLR	EA		0 0 0 0			8	EA <sub>n-1</sub> ← EA <sub>n</sub> , EA <sub>15</sub> ← CY, CY ← EA <sub>0</sub>	
	DSLL	EA		1 0 1 0 0 1 0 0			8	EA <sub>n+1</sub> ← EA <sub>n</sub> , EA <sub>0</sub> ← 0, CY ← EA <sub>15</sub>	
	DSLRL	EA		0 0 0 0			8	EA <sub>n-1</sub> ← EA <sub>n</sub> , EA <sub>15</sub> ← 0, CY ← EA <sub>0</sub>	
Jump	JMP *	word	0 1 0 1 0 1 0 0	← Low Adrs →	High Adrs		10	PC ← word	
	JB		0 0 1 0 0 0 0 1				4	PC <sub>H</sub> ← B, PC <sub>L</sub> ← C	
	JR	word	1 1 ← jdisp 1 →				10	PC ← PC+1+jdisp 1	
	JRE *	word	0 1 0 0 1 1 1 ← jdisp →				10	PC ← PC+2+jdisp	
	JEA		0 1 0 0 1 0 0 0	0 0 1 0 1 0 0 0			8	PC ← EA	
Call	CALL *	word	0 1 0 0 0 0 0 0	← Low Adrs →	High Adrs		16	(SP-1) ← (PC+3) <sub>H</sub> , (SP-2) ← (PC+3) <sub>L</sub> PC ← word, SP ← SP-2	
	CALB		0 1 0 0 1 0 0 0	0 0 1 0 1 0 0 1			17	(SP-1) ← (PC+2) <sub>H</sub> , (SP-2) ← (PC+2) <sub>L</sub> PC <sub>H</sub> ← B, PC <sub>L</sub> ← C, SP ← SP-2	
	CALF *	word	0 1 1 1 1 ← fa →				13	(SP-1) ← (PC+2) <sub>H</sub> , (SP-2) ← (PC+2) <sub>L</sub> PC <sub>15-11</sub> ← 00001, PC <sub>10-0</sub> ← fa, SP ← SP-2	

Instruction group	Mnemonic	Operand	Instruction code				State	Operation	Skip condition
			B1	B2	B3	B4			
Call	CALT	word	1 0 0 ← ta →				16	$(SP-1) \leftarrow (PC+1)_H, (SP-2) \leftarrow (PC+1)_L, PC_L \leftarrow (128+2ta), PC_H \leftarrow (129+2ta), SP \leftarrow SP-2$	
	SOFT1		0 1 1 1 0 0 1 0				16	$(SP-1) \leftarrow PSW, (SP-2) \leftarrow (PC+1)_H, (SP-3) \leftarrow (PC+1)_L, PC \leftarrow 0060H, SP \leftarrow SP-3$	
Return	RET		1 0 1 1 1 0 0 0				10	$PC_L \leftarrow (SP), PC_H \leftarrow (SP+1)$ $SP \leftarrow SP+2$	
	RETS		↓ 1 0 0 1				10	$PC_L \leftarrow (SP), PC_H \leftarrow (SP+1), SP \leftarrow SP+2$ $PC \leftarrow PC+n$	Unconditional
	RETI		0 1 1 0 0 0 1 0				13	$PC_L \leftarrow (SP), PC_H \leftarrow (SP+1)$ $PSW \leftarrow (SP+2), SP \leftarrow SP+3$	
Skip	BIT *	bit, wa	0 1 0 1 1 B <sub>2</sub> B <sub>1</sub> B <sub>0</sub>	← Offset →			10	Skip if (V.wa) bit = 1	(V.wa) bit = 1
	SK	f	0 1 0 0 1 0 0 0	0 0 0 0 1 F <sub>2</sub> F <sub>1</sub> F <sub>0</sub>			8	Skip if f = 1	f = 1
	SKN	f	↓ ↓ ↓ ↓	0 0 0 1 ↓			8	Skip if f = 0	f = 0
	SKIT	irf	↓ ↓ ↓ ↓	0 1 0 I <sub>4</sub> I <sub>3</sub> I <sub>2</sub> I <sub>1</sub> I <sub>0</sub>			8	Skip if irf = 1, then reset irf	irf = 1
	SKNIT	irf	↓ ↓ ↓ ↓	0 1 1 I <sub>4</sub> I <sub>3</sub> I <sub>2</sub> I <sub>1</sub> I <sub>0</sub>			8	Skip if irf = 0 Reset irf, if irf = 1	irf = 0
CPU operation	NOP		0 0 0 0 0 0 0 0				4	No Operation	
	EI		1 0 1 0 1 0 1 0				4	Enable Interrupt	
	DI		1 0 1 1 1 0 1 0				4	Disable Interrupt	
	HLT		0 1 0 0 1 0 0 0	0 0 1 1 1 0 1 1			12	Set Halt Mode	
	STOP		0 1 0 0 1 0 0 0	1 0 1 1 1 0 1 1			12	Set Stop Mode	

- Notes**
1. B2 (Data) is applied for rpa2 = D + byte or H + byte.
  2. B3 (Data) is applied for rpa3 = D + byte or H + byte.
  3. In the "state" column, data to the right of the slash applies when rpa2 or rpa3 is D + byte, H + A, H + B, H + EA, or H + byte.

**Remark** When the instructions below are skipped, the number of idle states is as listed below and differs from the number of execution states.

1-byte instruction	: 4-state	3-byte instruction (with *)	: 10-state
2-byte (with *)	: 7-state	3-byte	: 11-state
2-byte	: 8-state	4-byte	: 14-state

4. LIST OF MODE REGISTERS

Name of mode register		Read/Write	Function
MA	MODE A	W	Specifies input/output of Port A in bit units
MB	MODE B	W	Specifies input/output of Port B in bit units
MCC	MODE CONTROL C	W	Specifies port/control mode of Port C in bit units
MC	MODE C	W	Specifies input/output of Port C set in the port mode in bit units
MM	MEMORY MAPPING	W	Specifies port/expansion mode of Ports D and F
MF	MODE F	W	Specifies input/output of Port F set in the port mode in bit units
TMM	Timer mode	R/W	Specifies operation mode of the timer
ETMM	Timer/Event Counter Mode	W	Specifies operation mode of the Timer Event Counter
EOM	Timer/Event Counter Output Mode	R/W	Controls output level of CO0 and CO1
SML	Serial Mode	W	Specifies operation mode of the serial interface
SMH		R/W	
MKL	Interrupt Mask	R/W	Specifies interrupt request enable/disable
MKH			
ANM	A/D Channel Mode	R/W	Specifies operation mode of the A/D converter
ZCM	Zero-cross Mode	W	Specifies operation mode of the zero-cross detection circuit

5. ELECTRICAL SPECIFICATIONS

ABSOLUTE MAXIMUM RATINGS (T<sub>A</sub> = 25 °C)

Parameter	Symbol	Test Condition	Ratings	Unit
Power Supply Voltage	V <sub>DD</sub>		-0.5 to +7.0	V
	AV <sub>DD</sub>		AV <sub>SS</sub> to V <sub>DD</sub> + 0.5	V
	AV <sub>SS</sub>		-0.5 to +0.5	V
Input Voltage	V <sub>I</sub>		-0.5 to V <sub>DD</sub> + 0.5	V
Output Voltage	V <sub>O</sub>		-0.5 to V <sub>DD</sub> + 0.5	V
Output Current Low	I <sub>OL</sub>	All Output Pin	4.0	mA
		All Output Pin Total	100	mA
Output Current High	I <sub>OH</sub>	All Output Pin	-2.0	mA
		All Output Pin Total	-50	mA
A/D Converter Reference Input Voltage	V <sub>AREF</sub>		-0.5 to AV <sub>DD</sub> + 0.3	V
Operating Ambient Temperature	T <sub>A</sub>		-40 to +85	°C
Storage Temperature	T <sub>stg</sub>		-65 to +150	°C

\* **Caution** If any of the parameters exceeds the absolute maximum ratings even for a moment, this may damage product quality. The absolute maximum ratings are values that may physically damage the product. You must use the product within the specified ratings.

**Oscillation Characteristics** ( $T_A = -40$  to  $+85$  °C,  $V_{DD} = AV_{DD} = +5.0$  V  $\pm$  10 %,  $V_{SS} = AV_{SS} = 0$  V,  $V_{DD} - 0.8$  V  $\leq AV_{DD} \leq V_{DD}$ ,  $3.4$  V  $\leq V_{AREF} \leq AV_{DD}$ )

Resonator	Recommended Circuits	Parameter	Test Conditions	MIN.	MAX.	UNIT
Ceramic Resonator or Crystal Resonator <sup>Note</sup>		Oscillation Frequency (f <sub>xx</sub> )	A/D Converter Not used	4	15	MHz
			A/D Converter Used	5.8	15	MHz
External Clock		X1 Input Frequency (f <sub>x</sub> )	A/D Converter Not used	4	15	MHz
			A/D Converter Used	5.8	15	MHz
		X1 Input Rise, Fall Time (t <sub>r</sub> , t <sub>f</sub> )		0	20	ns
		X1 Input High, Low Level Width (t <sub>0H</sub> , t <sub>0L</sub> )		20	250	ns

- Cautions**
1. Oscillator circuit should be in the nearest area from X1 and X2 pins.
  2. Do not place other signal lines within the area enclosed with broken lines.

**Note** For a crystal resonator, the following external capacitances are recommended: C<sub>1</sub> = C<sub>2</sub> = 10 pF

**CAPACITANCE** ( $T_A = 25$  °C,  $V_{DD} = V_{SS} = 0$  V)

Parameter	Symbol	Test Condition	MIN.	TYP.	MAX.	UNIT
Input Capacitance	C <sub>i</sub>	f <sub>c</sub> = 1 MHz			10	pF
Output Capacitance	C <sub>o</sub>	Unmeasured pins returned to 0 V			20	pF
I/O Capacitance	C <sub>io</sub>				20	pF

**DC CHARACTERISTICS** ( $T_A = -40$  to  $+85$  °C,  $V_{DD} = AV_{DD} = +5.0$  V  $\pm$  10 %,  $V_{SS} = AV_{SS} = 0$  V)

Parameter	Symbol	Test Condition	MIN.	TYP.	MAX.	UNIT
Input Low Voltage	V <sub>IL1</sub>	All except RESET, STOP, NMI, SCK, INT1, TI, AN7 to AN4	0		0.8	V
	V <sub>IL2</sub>	RESET, STOP, NMI, SCK, INT1, TI, AN7 to AN4	0		0.2V <sub>DD</sub>	V
Input High Voltage	V <sub>IH1</sub>	All except RESET, STOP, NMI, SCK, INT1, TI, AN7 to AN4, X1, X2	2.2		V <sub>DD</sub>	V
	V <sub>IH2</sub>	RESET, STOP, NMI, SCK, INT1, TI, AN7 to AN4, X1, X2	0.8V <sub>DD</sub>		V <sub>DD</sub>	V
Output Low Voltage	V <sub>OL</sub>	I <sub>OL</sub> = 2.0 mA			0.45	V
Output High Voltage	V <sub>OH</sub>	I <sub>OH</sub> = -1.0 mA	V <sub>DD</sub> -1.0			V
		I <sub>OH</sub> = -100 μA	V <sub>DD</sub> -0.5			V
Input Current	I <sub>I</sub>	INT1 <sup>Note 1</sup> , TI (PC3) <sup>Note 2</sup> ; 0 V ≤ V <sub>I</sub> ≤ V <sub>DD</sub>			±200	μA
Input Leakage Current	I <sub>LI</sub>	All except INT1, TI (PC3), AN7 to AN0; 0 V ≤ V <sub>I</sub> ≤ V <sub>DD</sub>			±10	μA
		AN7 to AN0; 0 V ≤ V <sub>I</sub> ≤ V <sub>DD</sub>			±1	μA
Output Leakage Current	I <sub>LO</sub>	0 V ≤ V <sub>O</sub> ≤ V <sub>DD</sub>			±10	μA
AV <sub>DD</sub> Supply Current	A <sub>DD1</sub>	Operation Mode f <sub>xx</sub> = 15 MHz		0.5	1.3	mA
	A <sub>DD2</sub>	STOP Mode		10	20	μA
V <sub>DD</sub> Supply Current	I <sub>DD1</sub>	Operation mode f <sub>xx</sub> = 15 MHz		16	30	mA
	I <sub>DD2</sub>	HALT Mode f <sub>xx</sub> = 15 MHz		8	15	mA
Data Retention Voltage	V <sub>DDDR</sub>	Hardware/Software STOP Mode	2.5			V
Data Retention Current	I <sub>DDDR</sub>	Hardware/Software <sup>Note 3</sup> STOP Mode	V <sub>DDDR</sub> = 2.5 V	1	15	μA
			V <sub>DDDR</sub> = 5 V $\pm$ 10 %	10	50	μA

- Notes**
1. When self-bias is generated by ZCM register.
  2. When set in the control mode by MCC register and self-bias is generated by ZCM register.
  3. When self-bias is not generated.



AC CHARACTERISTICS (T<sub>A</sub> = -40 to +85 °C, V<sub>DD</sub> = AV<sub>DD</sub> = +5.0 V ± 10 %, V<sub>SS</sub> = AV<sub>SS</sub> = 0 V)

READ/WRITE OPERATION:

Parameter	Symbol	Test Condition	MIN.	MAX.	UNIT
X1 Input Cycle Time	t <sub>CYC</sub>		66	250	ns
Address Setup Time to ALE	t <sub>AL</sub>	f <sub>xx</sub> = 15 MHz, C <sub>L</sub> = 150 pF	30		ns
Address Hold Time after ALE ↓	t <sub>LA</sub>		35		ns
Address → RD ↓ Delay Time	t <sub>AR</sub>		100		ns
RD ↓ → Address Floating Time	t <sub>AFR</sub>	C <sub>L</sub> = 150 pF		20	ns
Address → Data Input Time	t <sub>AD</sub>	f <sub>xx</sub> = 15 MHz, C <sub>L</sub> = 150 pF		250	ns
ALE ↓ → Data Input Time	t <sub>LDR</sub>			135	ns
RD ↓ → Data Input Time	t <sub>RD</sub>			120	ns
ALE ↓ → RD ↓ Delay Time	t <sub>LR</sub>		15		ns
Data Hold Time after RD ↑	t <sub>RDH</sub>	C <sub>L</sub> = 150 pF	0		ns
RD ↑ → ALE ↑ Delay Time	t <sub>RL</sub>	f <sub>xx</sub> = 15 MHz, C <sub>L</sub> = 150 pF	80		ns
RD Width Low	t <sub>RR</sub>	Data Read f <sub>xx</sub> = 15 MHz, C <sub>L</sub> = 150 pF	215		ns
		OP code Fetch f <sub>xx</sub> = 15 MHz, C <sub>L</sub> = 150 pF	415		ns
ALE Width High	t <sub>LL</sub>	f <sub>xx</sub> = 15 MHz, C <sub>L</sub> = 150 pF	90		ns
M1 Setup Time to ALE ↓	t <sub>ML</sub>	f <sub>xx</sub> = 15 MHz	30		ns
M1 Hold Time after ALE ↓	t <sub>LM</sub>		35		ns
IO/M Setup Time to ALE ↓	t <sub>IL</sub>		30		ns
IO/M Hold Time after ALE ↓	t <sub>LI</sub>		35		ns
Address → WR ↓ Delay Time	t <sub>AW</sub>	f <sub>xx</sub> = 15 MHz, C <sub>L</sub> = 150 pF	100		ns
ALE ↓ → Data Output Time	t <sub>LDW</sub>			180	ns
WR ↓ → Data Output Time	t <sub>WD</sub>	C <sub>L</sub> = 150 pF		100	ns
ALE ↓ → WR ↓ Delay Time	t <sub>LW</sub>	f <sub>xx</sub> = 15 MHz, C <sub>L</sub> = 150 pF	15		ns
Data Setup Time to WR ↑	t <sub>DW</sub>		165		ns
Data Hold Time after WR ↑	t <sub>WDH</sub>		60		ns
WR ↑ → ALE ↑ Delay Time	t <sub>WL</sub>		80		ns
WR Width Low	t <sub>WW</sub>		215		ns

**SERIAL OPERATION:**

Parameter	Symbol	Test Condition	MIN.	MAX.	UNIT	
SCK Cycle Time	t <sub>cyk</sub>	SCK Input	<b>Note 1</b>	800		ns
			<b>Note 2</b>	400		ns
		SCK Output		1.6		μs
SCK Width Low	t <sub>kkl</sub>	SCK Input	<b>Note 1</b>	335		ns
			<b>Note 2</b>	160		ns
		SCK Output		700		ns
SCK Width High	t <sub>kkh</sub>	SCK Input	<b>Note 1</b>	335		ns
			<b>Note 2</b>	160		ns
		SCK Output		700		ns
RxD Setup Time to SCK ↑	t <sub>rxk</sub>	<b>Note 1</b>	80		ns	
RxD Hold Time After SCK ↑	t <sub>krx</sub>	<b>Note 1</b>	80		ns	
SCK ↓ → TxD Delay Time	t <sub>ktx</sub>	<b>Note 1</b>		210	ns	

- Notes**
1. In case of x1 clock rate in asynchronous mode, synchronous mode, or I/O interface mode.
  2. In case of x16 or x64 clock rate in asynchronous mode.

**Remark** The numeric values in the table apply when f<sub>xx</sub> = 15 MHz, C<sub>L</sub> = 150 pF.

**ZERO-CROSS CHARACTERISTICS:**

Parameter	Symbol	Test Condition	MIN.	MAX.	UNIT
Zero-Cross Detection Input	V <sub>zx</sub>	AC Coupled	1	1.8	V <sub>ACP-P</sub>
Zero-Cross Accuracy	A <sub>zx</sub>	60-Hz Sine Wave		±135	mV
Zero-Cross Detection Input Frequency	f <sub>zx</sub>		0.05	1	kHz

**OTHER OPERATION:**

Parameter	Symbol	Test Condition	MIN.	MAX.	UNIT
TI Width High, Low	t <sub>tiH</sub> , t <sub>tiL</sub>		6		t <sub>cyk</sub>
CI Width High, Low	t <sub>ci1H</sub> , t <sub>ci1L</sub>	Event Counter Mode	6		t <sub>cyk</sub>
	t <sub>ci2H</sub> , t <sub>ci2L</sub>	Pulse Width Measurement Mode	48		t <sub>cyk</sub>
NMI Width High, Low	t <sub>niH</sub> , t <sub>niL</sub>		10		μs
INT1 Width High, Low	t <sub>i1H</sub> , t <sub>i1L</sub>		36		t <sub>cyk</sub>
INT2 Width High, Low	t <sub>i2H</sub> , t <sub>i2L</sub>		36		t <sub>cyk</sub>
AN7-4 Width High, Low	t <sub>anh</sub> , t <sub>anl</sub>		36		t <sub>cyk</sub>
RESET Width High, Low	t <sub>rsh</sub> , t <sub>rsl</sub>		10		μs

**A/D CONVERTER CHARACTERISTICS:** ( $T_A = -40$  to  $+85$  °C,  $V_{DD} = +5.0$  V  $\pm$  10 %,  $V_{SS} = AV_{SS} = 0$  V,  $V_{DD} - 0.5$  V  $\leq$   $AV_{DD} \leq V_{DD}$ ,  $3.4$  V  $\leq$   $V_{AREF} \leq AV_{DD}$ )

Parameter	Symbol	Test Condition	MIN.	TYP.	MAX.	UNIT
Resolution			8			Bits
Absolute Accuracy <sup>Note</sup>		$3.4$ V $\leq$ $V_{AREF} \leq AV_{DD}$ , $66$ ns $\leq$ $t_{CYC} \leq 170$ ns			$\pm 0.8$ %	FSR
		$4.0$ V $\leq$ $V_{AREF} \leq AV_{DD}$ , $66$ ns $\leq$ $t_{CYC} \leq 170$ ns			$\pm 0.6$ %	FSR
		$T_A = -10$ to $+70$ °C, $4.0$ V $\leq$ $V_{AREF} \leq AV_{DD}$ , $66$ ns $\leq$ $t_{CYC} \leq 170$ ns			$\pm 0.4$ %	FSR
Conversion time	$t_{CONV}$	$66$ ns $\leq$ $t_{CYC} \leq 110$ ns	576			$t_{CYC}$
		$110$ ns $\leq$ $t_{CYC} \leq 170$ ns	432			$t_{CYC}$
Sampling Time	$t_{SAMP}$	$66$ ns $\leq$ $t_{CYC} \leq 110$ ns	96			$t_{CYC}$
		$110$ ns $\leq$ $t_{CYC} \leq 170$ ns	72			$t_{CYC}$
Analog Input Voltage	$V_{IAN}$	AN7-0 (include unused pins)	0		$V_{AREF}$	V
Analog Input Impedance	$R_{AN}$			50		MΩ
Reference Voltage	$V_{AREF}$		3.4		$AV_{DD}$	V
$V_{AREF}$ Current	$I_{AREF1}$	Operation mode		1.5	3.0	mA
	$I_{AREF2}$	STOP mode		0.7	1.5	mA
$AV_{DD}$ Supply Current	$AI_{DD1}$	Operation mode, $f_{xx} = 15$ MHz		0.5	1.3	mA
	$AI_{DD2}$	STOP mode		10	20	μA

\*

**Note** Except quantization error (i.e.  $\pm 1/2$  LSB).

**AC TIMING TEST POINTS**

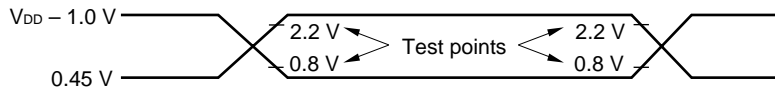

AC CHARACTERISTIC CALCULATING EXPRESSION depending on  $t_{CYC}$

Symbol	Calculating Expression	MIN./MAX.	UNIT
$t_{AL}$	$2T - 100$	MIN.	ns
$t_{LA}$	$T - 30$	MIN.	ns
$t_{AR}$	$3T - 100$	MIN.	ns
$t_{AD}$	$7T - 220$	MAX.	ns
$t_{LDR}$	$5T - 200$	MAX.	ns
$t_{RD}$	$4T - 150$	MAX.	ns
$t_{LR}$	$T - 50$	MIN.	ns
$t_{RL}$	$2T - 50$	MIN.	ns
$t_{RR}$	$4T - 50$ (Data Read)	MIN.	ns
	$7T - 50$ (OP Code Fetch)		
$t_{LL}$	$2T - 40$	MIN.	ns
$t_{ML}$	$2T - 100$	MIN.	ns
$t_{LM}$	$T - 30$	MIN.	ns
$t_{lL}$	$2T - 100$	MIN.	ns
$t_{lI}$	$T - 30$	MIN.	ns
$t_{AW}$	$3T - 100$	MIN.	ns
$t_{LDW}$	$T + 110$	MAX.	ns
$t_{LW}$	$T - 50$	MIN.	ns
$t_{DW}$	$4T - 100$	MIN.	ns
$t_{WDH}$	$2T - 70$	MIN.	ns
$t_{WL}$	$2T - 50$	MIN.	ns
$t_{WW}$	$4T - 50$	MIN.	ns
$t_{CYK}$	$6T$ ( $\overline{SCK}$ Input) <sup>Note 1</sup> / $12T$ ( $\overline{SCK}$ Input) <sup>Note 2</sup>	MIN.	ns
	$24T$ ( $\overline{SCK}$ Output)		
$t_{KKL}$	$2.5T + 5$ ( $\overline{SCK}$ Input) <sup>Note 1</sup> / $5T + 5$ ( $\overline{SCK}$ Input) <sup>Note 2</sup>	MIN.	ns
	$12T - 100$ ( $\overline{SCK}$ Output)		
$t_{KKh}$	$2.5T + 5$ ( $\overline{SCK}$ Input) <sup>Note 1</sup> / $5T + 5$ ( $\overline{SCK}$ Input) <sup>Note 2</sup>	MIN.	ns
	$12T - 100$ ( $\overline{SCK}$ Output)		

- Notes**
1. In case of x16 or x64 clock rate in asynchronous mode.
  2. In case of x1 clock rate in asynchronous mode, synchronous mode, or I/O interface mode.

- Remarks**
1.  $T = t_{CYC} = 1/f_{xx}$
  2. Symbols that cannot be found in this table do not depend on the oscillation frequency ( $f_{xx}$ ).

Timing Waveform

Read Operation

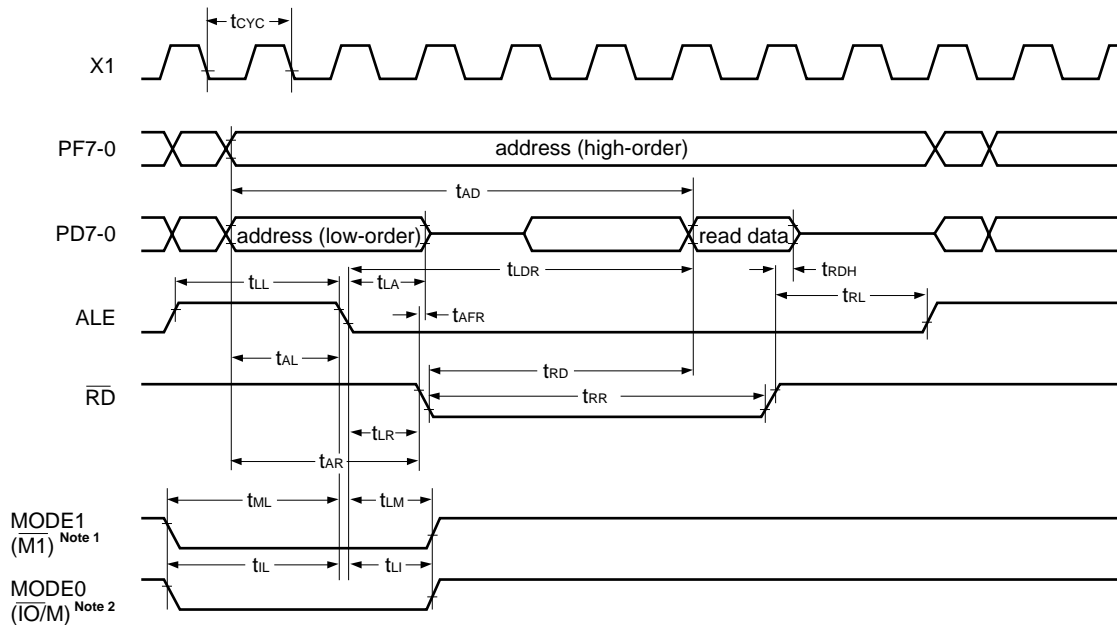

Write Operation

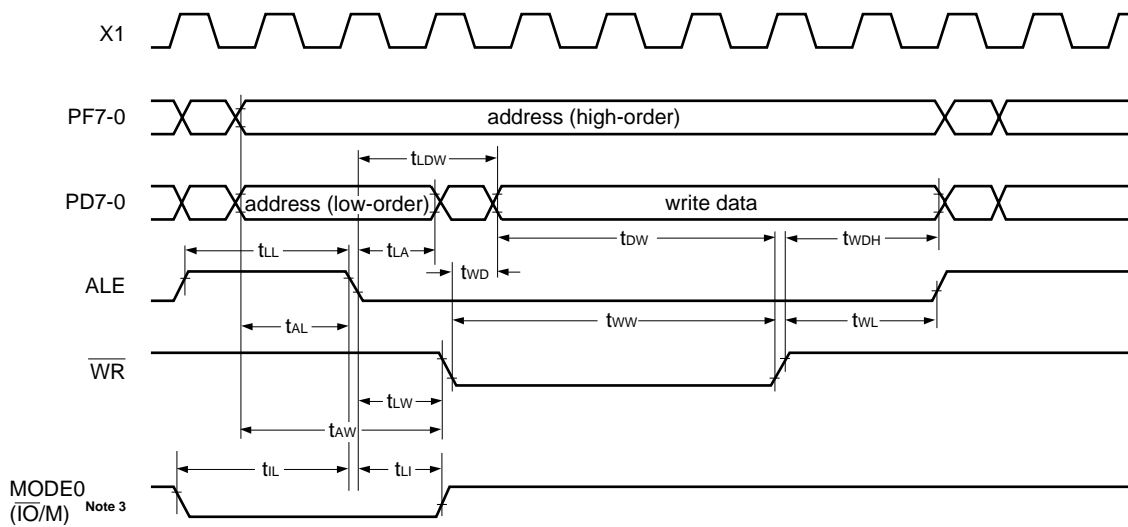

- Notes**
1.  $\overline{M1}$  signal is output to MODE1 pin at first OP code fetch cycle if MODE1 pin is pulled up.
  2.  $\overline{IO/M}$  signal is output to MODE0 pin at sr to sr2 register read cycle if MODE0 pin is pulled up.
  3.  $\overline{IO/M}$  signal is output to MODE0 pin at sr to sr2 register write cycle if MODE0 pin is pulled up.

Serial Operation

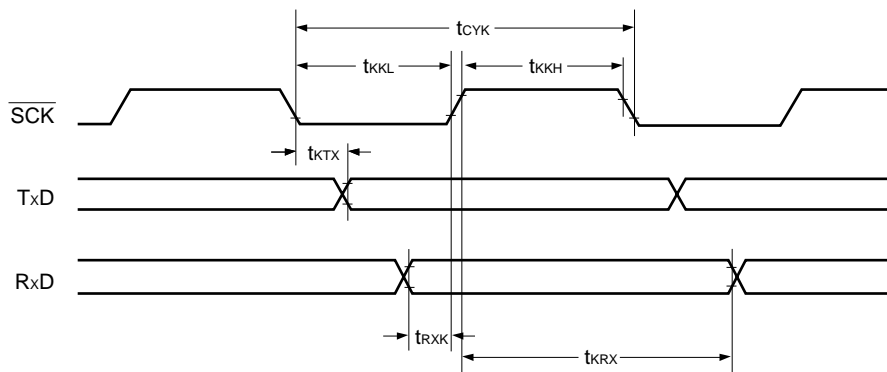

Timer Input Timing

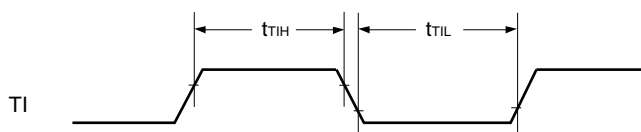

Timer/Event Counter Input Timing

Event Counter Mode

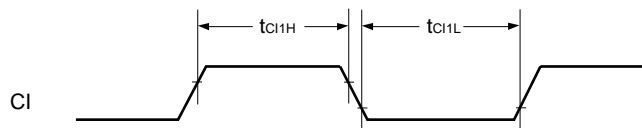

Pulse Width Measurement Mode

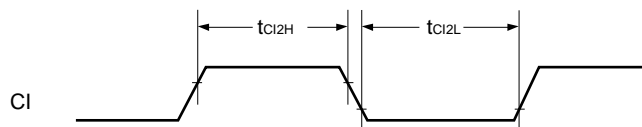

Interrupt Input Timing

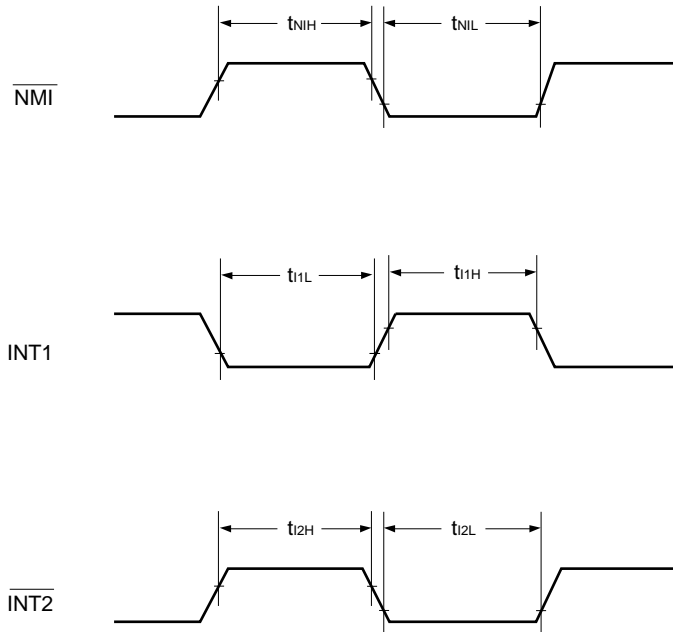

RESET Input Timing

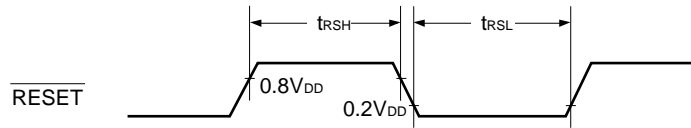

External Clock Timing

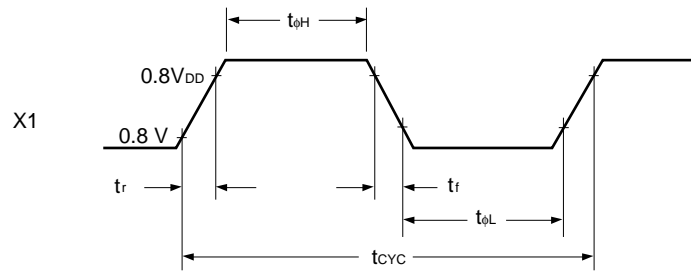

Data Memory STOP Mode Low Supply Voltage Data Retention Characteristics (T<sub>A</sub> = -40 to +85 °C)

\*

Parameter	Symbol	Test Condition	MIN.	TYP.	MAX.	UNIT
Data retention power supply voltage	V <sub>DDDR</sub>		2.5		5.5	V
Data retention power supply current	I <sub>DDDR</sub>	V <sub>DDDR</sub> = 2.5 V		1	15	μA
		V <sub>DDDR</sub> = 5 V ± 10 %		10	50	μA
V <sub>DD</sub> rise, fall time	t <sub>rVD</sub> , t <sub>fVD</sub>		200			μs
STOP setup time to V <sub>DD</sub>	t <sub>sSTVD</sub>		12T <sup>Note</sup> + 0.5			μs
STOP hold time to V <sub>DD</sub>	t <sub>hVDST</sub>		12T <sup>Note</sup> + 0.5			μs

Note T = t<sub>cyc</sub> = 1/f<sub>xx</sub>

Data Retention Timing

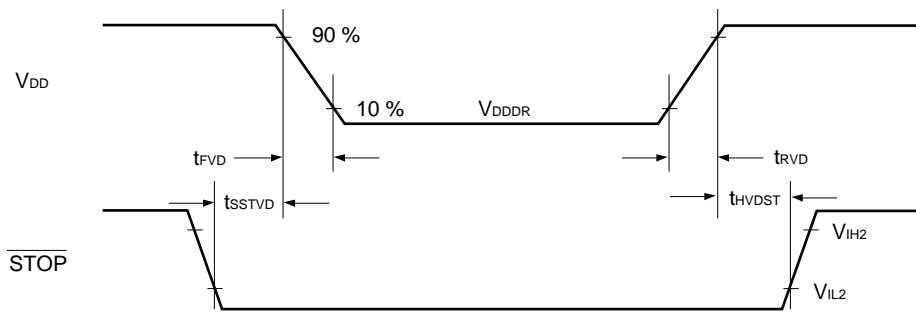



6. CHARACTERISTIC CURVES (reference value)

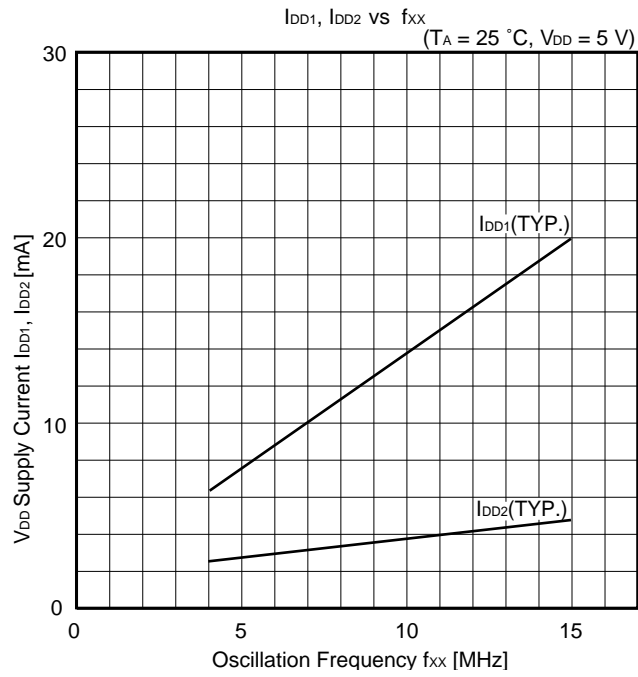
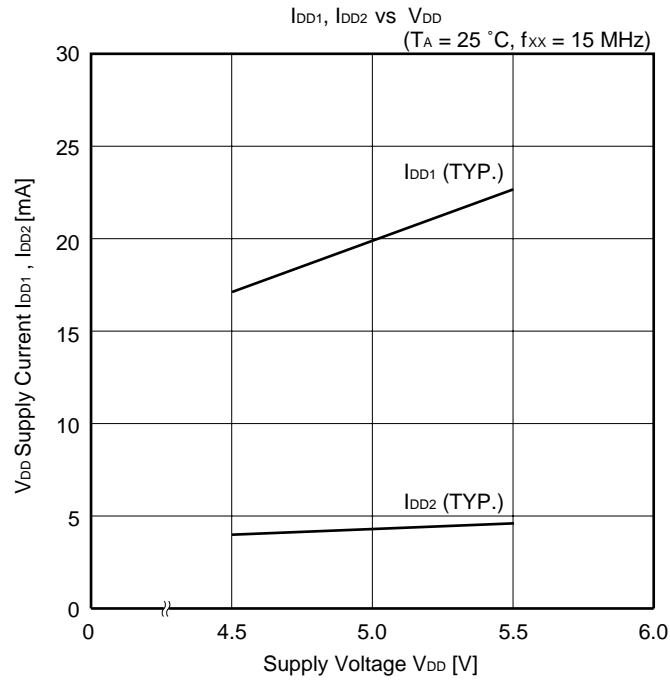

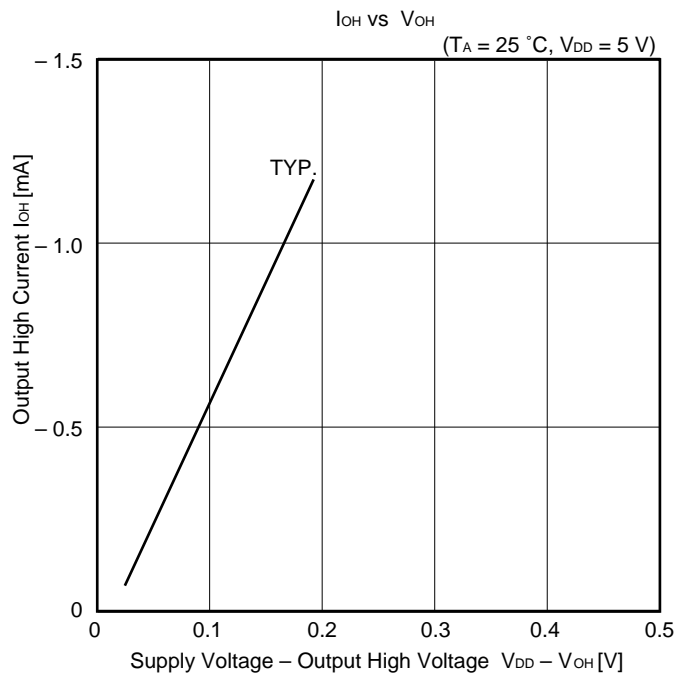
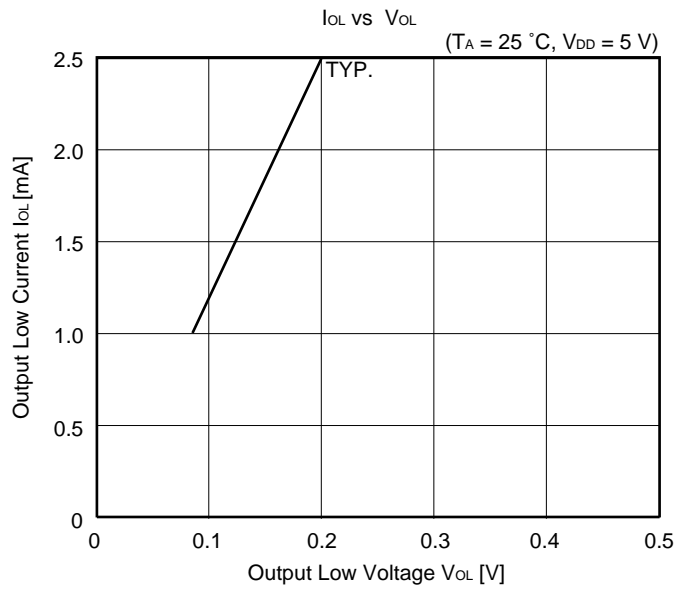

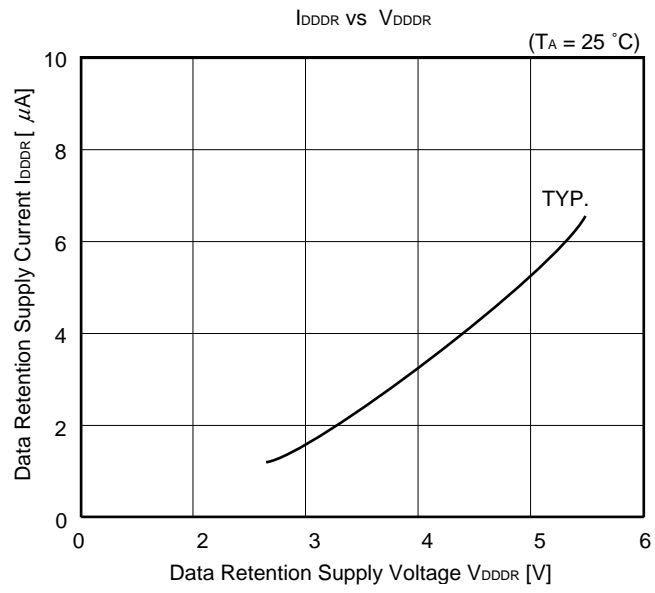

7. PACKAGE DRAWINGS

64 PIN PLASTIC QUIP

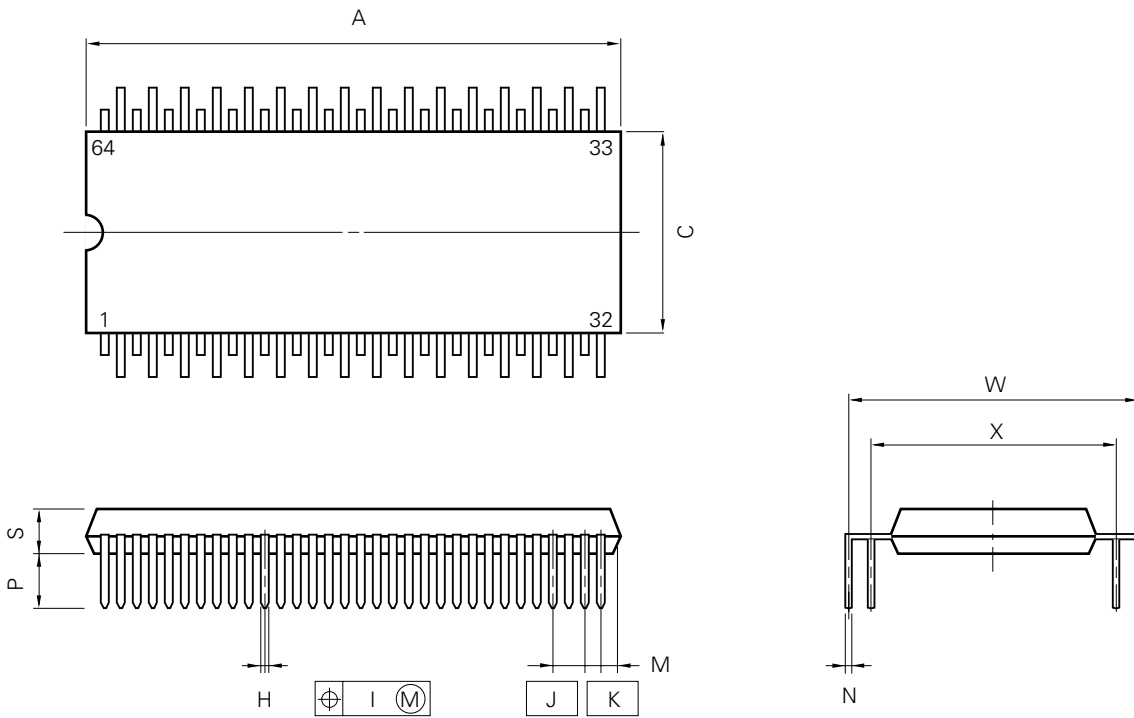

**NOTE**

Each lead centerline is located within 0.25 mm (0.010 inch) of its true position (T.P.) at maximum material condition.

P64GQ-100-36

ITEM	MILLIMETERS	INCHES
A	41.5 <sup>+0.3</sup> <sub>-0.2</sub>	1.634 <sup>+0.012</sup> <sub>-0.008</sub>
C	16.5	0.650
H	0.50 <sup>+0.10</sup>	0.020 <sup>+0.004</sup> <sub>-0.005</sub>
I	0.25	0.010
J	2.54 (T.P.)	0.100 (T.P.)
K	1.27 (T.P.)	0.050 (T.P.)
M	1.1 <sup>+0.25</sup> <sub>-0.15</sub>	0.043 <sup>+0.011</sup> <sub>-0.006</sub>
N	0.25 <sup>+0.10</sup> <sub>-0.05</sub>	0.010 <sup>+0.004</sup> <sub>-0.003</sub>
P	4.0 <sup>+0.3</sup>	0.157 <sup>+0.013</sup> <sub>-0.012</sub>
S	3.6 <sup>+0.1</sup>	0.142 <sup>+0.004</sup> <sub>-0.005</sub>
W	24.13 <sup>±1.05</sup>	0.950 <sup>±0.042</sup>
X	19.05 <sup>±1.05</sup>	0.750 <sup>±0.042</sup>

64 PIN PLASTIC QFP (14x20)

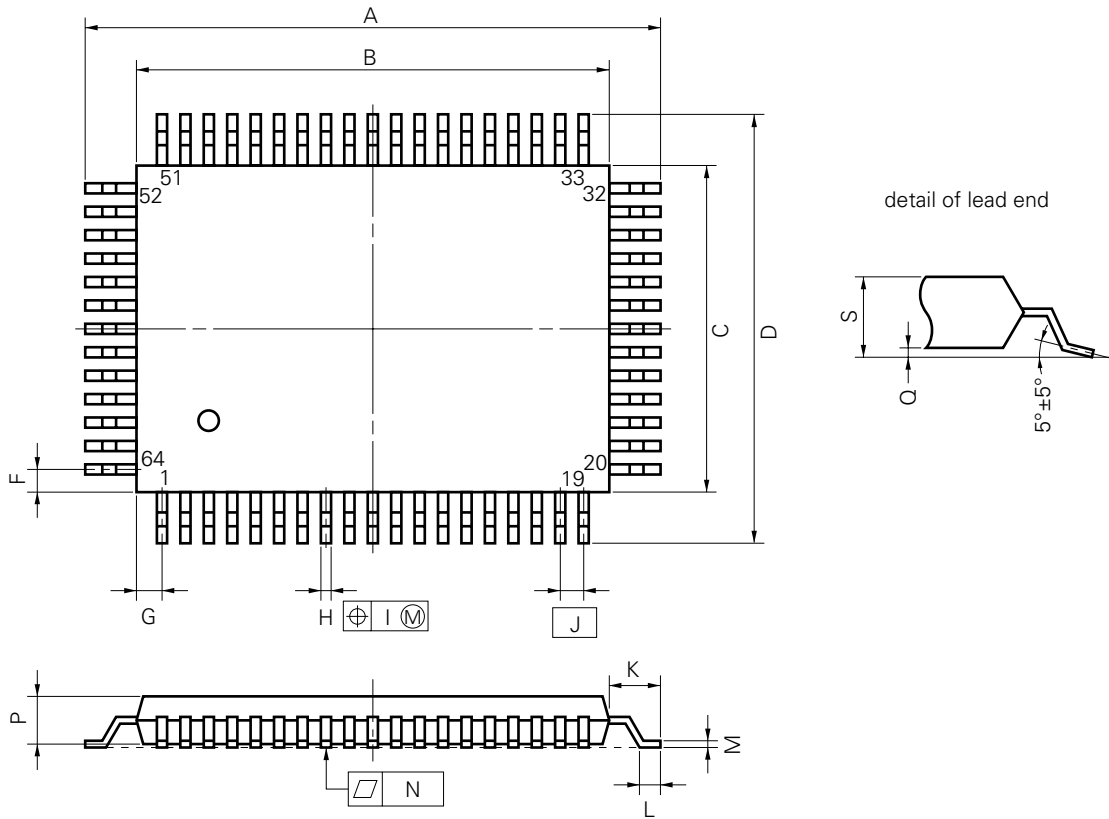

**NOTE**

Each lead centerline is located within 0.20 mm (0.008 inch) of its true position (T.P.) at maximum material condition.

P64GF-100-3B8,3BE,3BR-1

ITEM	MILLIMETERS	INCHES
A	23.6±0.4	0.929±0.016
B	20.0±0.2	0.795 <sup>+0.009</sup> <sub>-0.008</sub>
C	14.0±0.2	0.551 <sup>+0.009</sup> <sub>-0.008</sub>
D	17.6±0.4	0.693±0.016
F	1.0	0.039
G	1.0	0.039
H	0.40±0.10	0.016 <sup>+0.004</sup> <sub>-0.005</sub>
I	0.20	0.008
J	1.0 (T.P.)	0.039 (T.P.)
K	1.8±0.2	0.071 <sup>+0.008</sup> <sub>-0.009</sub>
L	0.8±0.2	0.031 <sup>+0.009</sup> <sub>-0.008</sub>
M	0.15 <sup>+0.10</sup> <sub>-0.05</sub>	0.006 <sup>+0.004</sup> <sub>-0.003</sub>
N	0.12	0.005
P	2.7	0.106
Q	0.1±0.1	0.004±0.004
S	3.0 MAX.	0.119 MAX.

68 PIN PLASTIC QFJ (□ 950 mil)

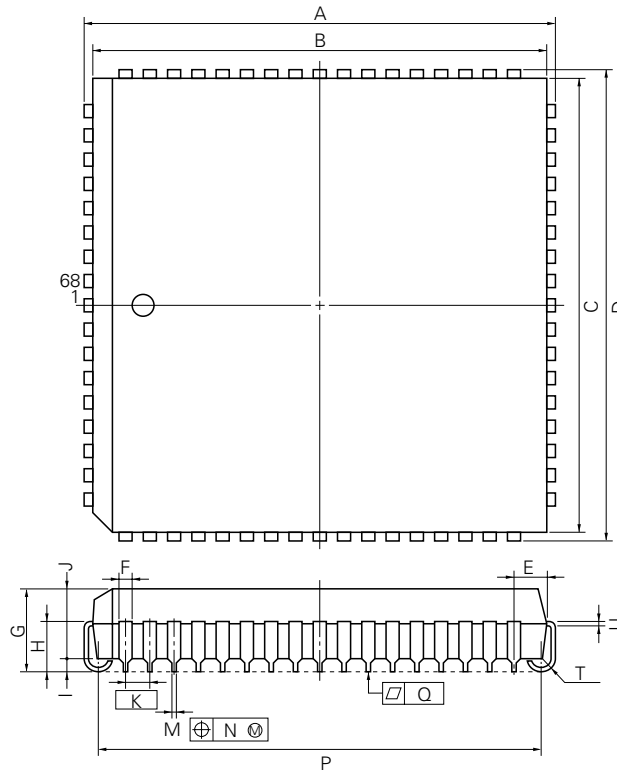

P68L-50A1-2

**NOTE**

Each lead centerline is located within 0.12 mm (0.005 inch) of its true position (T.P.) at maximum material condition.

ITEM	MILLIMETERS	INCHES
A	25.2±0.2	0.992±0.008
B	24.20	0.953
C	24.20	0.953
D	25.2±0.2	0.992±0.008
E	1.94±0.15	0.076 <sup>+0.007</sup> <sub>-0.006</sub>
F	0.6	0.024
G	4.4±0.2	0.173 <sup>+0.009</sup> <sub>-0.008</sub>
H	2.8±0.2	0.110 <sup>+0.009</sup> <sub>-0.008</sub>
I	0.9 MIN.	0.035 MIN.
J	3.4	0.134
K	1.27 (T.P.)	0.050 (T.P.)
M	0.40±1.0	0.016 <sup>+0.004</sup> <sub>-0.005</sub>
N	0.12	0.005
P	23.12±0.20	0.910 <sup>+0.009</sup> <sub>-0.008</sub>
Q	0.15	0.006
T	R 0.8	R 0.031
U	0.20 <sup>+0.10</sup> <sub>-0.05</sub>	0.008 <sup>+0.004</sup> <sub>-0.002</sub>

8. RECOMMENDED SOLDERING CONDITIONS

\*

Solder the μPD78C14(A) under the recommended conditions listed below.

For details of the recommended conditions for soldering, please refer to **Semiconductor Device Mounting Technology Manual (IEI-1207)**.

Consult an NEC sales representative about soldering methods and soldering conditions other than listed below.

Table 8-1. Soldering Conditions for Surface Mount Type

(1) μPD78C14GF(A)-xxx-3BE: 64-pin plastic QFP (14 x 20 mm)

Soldering Method	Soldering Conditions	Recommended Condition Symbol
Infrared reflow	Package peak temperature: 235 °C, Time: Within 30 s (at 210 °C or higher), Count: Twice or less <Attention> (1) Perform the second reflow when the device temperature has come down to the room temperature from the heating from the first reflow. (2) Do not wash the soldered portion with the flux following the first reflow.	IR35-00-2
VPS	Package peak temperature: 215 °C, Time: Within 40 s (at 200 °C or higher), Count: Twice or less <Attention> (1) Perform the second reflow when the device temperature has come down to the room temperature from the heating from the first reflow. (2) Do not wash the soldered portion with the flux following the first reflow.	VP15-00-2
Wave soldering	Soldering bath temperature: 260 °C or less, Time: Within 10 s, Count: Once, Preheating temperature: 120 °C MAX. (package surface temperature)	WS60-00-1
Partial heating	Pin temperature: 300 °C or less, Time: Within 3 s (per pin row)	—

**Caution Do not use several soldering methods together (except partial heating).**

(2) μPD78C14L (A)-xxx: 68-pin plastic QFJ (950 x 950 mil)

Soldering Method	Soldering Conditions	Recommended Condition Symbol
Infrared reflow	Package peak temperature: 230 °C, Time: Within 30 s (at 210 °C or higher), Count: Once, Maximum number of days: Seven <sup>Note</sup> (after seven days, prebaking at 125 °C is required for 10 hours)	IR30-107-1
VPS	Package peak temperature: 215 °C, Time: Within 40 s (at 200 °C or higher), Count: Once, Maximum number of days: Seven <sup>Note</sup> (after seven days, prebaking at 125 °C is required for 10 hours)	VP15-107-1
Partial heating	Pin temperature: 300 °C or less, Time: Within 3 s (per pin row)	—

**Note** Number of storage days under the storage conditions of 25 °C and 65 % RH or less after the dry pack is opened.

**Caution Do not use several soldering methods together (except partial heating).**

Table 8-2. Soldering Conditions for Hole-Through Type

 $\mu$ PD78C14G(A)-xxx-36: 64-pin plastic QUIP

Soldering Method	Soldering Conditions
Wave Soldering (pin part only)	Soldering bath temperature: 260 °C or less, Time: Within 10 s
Partial heating	Pin temperature: 300 °C or less, Time: Within 3 s (per pin row)

**Caution** Apply wave soldering only to pins and be careful not to bring solder directly in contact with the package.



APPENDIX DEVELOPMENT TOOLS

\*

The following development tools are provided for system development using the μPD78C14(A):

Language processor

87AD series relocatable assembler (RA87)	This relocatable assembler is a program which converts a program written in mnemonics into object code that can be executed by microcontroller. In addition, it contains the automatic function of symbol table generation and branch instruction optimization processing.			
	Host machine			Ordering code (product name)
		OS	Distribution media	
	PC-9800 series	MS-DOS™ (Ver. 2.11 to Ver. 5.00A <sup>Note</sup> )	3.5-inch 2HD	μS5A13RA87
			5-inch 2HD	μS5A10RA87
IBM PC/AT™	PC DOS™ (Ver. 3.1)	3.5-inch 2HC	μS7B13RA87	
		5-inch 2HC	μS7B10RA87	

PROM write tools

Hard-ware	PG-1500	PG-1500 is a PROM programmer which enables you to program single chip microcontrollers containing PROM by stand-alone or host machine operation by connecting an attached board and optional programmer adapter to PG-1500. It also enables you to program typical PROM devices of 256 Kbits to 4 Mbits.			
	PA-78CP14GQ	PROM programmer adapter for the μPD78CP14(A) and connected to PG-1500 for use.			
Soft-ware	PG-1500 controller	PG-1500 and a host machine are connected by a serial or parallel interface and PG-1500 is controlled on the host machine.			
		Host machine			Ordering code (product name)
			OS	Distribution media	
		PC-9800 series	MS-DOS (Ver. 2.11 to Ver. 5.00A <sup>Note</sup> )	3.5-inch 2HD	μS5A13PG1500
				5-inch 2HD	μS5A10PG1500
IBM PC/AT	PC DOS (Ver. 3.1)	3.5-inch 2HD	μS7B13PG1500		
		5-inch 2HC	μS7B10PG1500		

**Note** Ver. 5.00/500A have task swap function. However, this function is not supported by this software.

**Remark** Operations of the assembler and PG-1500 controller are guaranteed only on the host machines under the operating systems listed above.

**Debugging tools**

In-circuit emulator (IE-78C11-M) is provided for μPD78C14(A) program debugging tools. The system configuration is listed below:

Hardware	IE-78C11-M	IE-78C11-M is an in-circuit emulator for the 87AD series. IE-78C11-M can be connected to a host machine efficient debugging.			
Software	IE-78C11-M control program (IE controller)	IE-78C11-M and a host machine are connected by RS-232-C and IE-78C11-M is controlled on the host machine.			
		Host machine		Ordering code (product name)	
			OS	Distribution media	
		PC-9800 series	MS-DOS (Ver. 2.11 to Ver. 3.30D)	3.5-inch 2HD 5-inch 2HD	μS5A13IE78C11 μS5A10IE78C11
	IBM PC/AT	PC DOS (Ver. 3.1)	5-inch 2HC	μS7B10IE78C11	

**Remark** Operation of IE controller is guaranteed only on the host machine under the operating systems listed above.

## NOTES FOR CMOS DEVICES

### (1) PRECAUTION AGAINST ESD FOR SEMICONDUCTORS

**Note:** Strong electric field, when exposed to a MOS device, can cause destruction of the gate oxide and ultimately degrade the device operation. Steps must be taken to stop generation of static electricity as much as possible, and quickly dissipate it once, when it has occurred. Environmental control must be adequate. When it is dry, humidifier should be used. It is recommended to avoid using insulators that easily build static electricity. Semiconductor devices must be stored and transported in an anti-static container, static shielding bag or conductive material. All test and measurement tools including work bench and floor should be grounded. The operator should be grounded using wrist strap. Semiconductor devices must not be touched with bare hands. Similar precautions need to be taken for PW boards with semiconductor devices on it.

### (2) HANDLING OF UNUSED INPUT PINS FOR CMOS

**Note:** No connection for CMOS device inputs can be cause of malfunction. If no connection is provided to the input pins, it is possible that an internal input level may be generated due to noise, etc., hence causing malfunction. CMOS device behave differently than Bipolar or NMOS devices. Input levels of CMOS devices must be fixed high or low by using a pull-up or pull-down circuitry. Each unused pin should be connected to  $V_{DD}$  or GND with a resistor, if it is considered to have a possibility of being an output pin. All handling related to the unused pins must be judged device by device and related specifications governing the devices.

### (3) STATUS BEFORE INITIALIZATION OF MOS DEVICES

**Note:** Power-on does not necessarily define initial status of MOS device. Production process of MOS does not define the initial operation status of the device. Immediately after the power source is turned ON, the devices with reset function have not yet been initialized. Hence, power-on does not guarantee out-pin levels, I/O settings or contents of registers. Device is not initialized until the reset signal is received. Reset operation must be executed immediately after power-on for devices having reset function.

MS-DOS is a trademark of Microsoft Corporation.

PC/AT and PC DOS are trademarks of IBM Corporation.

The export of this product from Japan is regulated by the Japanese government. To export this product may be prohibited without governmental license, the need for which must be judged by the customer. The export or re-export of this product from a country other than Japan may also be prohibited without a license from that country. Please call an NEC sales representative.

No part of this document may be copied or reproduced in any form or by any means without the prior written consent of NEC Corporation. NEC Corporation assumes no responsibility for any errors which may appear in this document.

NEC Corporation does not assume any liability for infringement of patents, copyrights or other intellectual property rights of third parties by or arising from use of a device described herein or any other liability arising from use of such device. No license, either express, implied or otherwise, is granted under any patents, copyrights or other intellectual property rights of NEC Corporation or others.

While NEC Corporation has been making continuous effort to enhance the reliability of its semiconductor devices, the possibility of defects cannot be eliminated entirely. To minimize risks of damage or injury to persons or property arising from a defect in an NEC semiconductor device, customer must incorporate sufficient safety measures in its design, such as redundancy, fire-containment, and anti-failure features.

NEC devices are classified into the following three quality grades:

“Standard”, “Special”, and “Specific”. The Specific quality grade applies only to devices developed based on a customer designated “quality assurance program” for a specific application. The recommended applications of a device depend on its quality grade, as indicated below. Customers must check the quality grade of each device before using it in a particular application.

Standard: Computers, office equipment, communications equipment, test and measurement equipment, audio and visual equipment, home electronic appliances, machine tools, personal electronic equipment and industrial robots

Special: Transportation equipment (automobiles, trains, ships, etc.), traffic control systems, anti-disaster systems, anti-crime systems, safety equipment and medical equipment (not specifically designed for life support)

Specific: Aircrafts, aerospace equipment, submersible repeaters, nuclear reactor control systems, life support systems or medical equipment for life support, etc.

The quality grade of NEC devices in “Standard” unless otherwise specified in NEC's Data Sheets or Data Books. If customers intend to use NEC devices for applications other than those specified for Standard quality grade, they should contact NEC Sales Representative in advance.

Anti-radioactive design is not implemented in this product.