

TI CC3000 Evaluation Module

User's Guide



Literature Number: SWRU326
November 2012

| | |
|--|-----------|
| Preface | 4 |
| 1 Introduction | 5 |
| 2 CC3000 EM Board | 6 |
| 2.1 EM Board Top View | 6 |
| 2.2 EM Board Bottom View | 9 |
| 2.3 Antenna | 10 |
| 2.4 Hardware Setup | 13 |
| 2.5 Schematics | 14 |
| 2.6 Bill of Materials (BOM) | 15 |
| 3 Layout Guidelines | 16 |
| 4 Application Development | 21 |

List of Figures

| | | |
|------|--|----|
| 2-1. | CC3000 EM Board Top View..... | 6 |
| 2-2. | CC3000 EM Board Bottom View..... | 9 |
| 2-3. | Antenna Location and RF Trace Routing | 10 |
| 2-4. | Matching Circuit Between the Antenna and the CC3000 EM Board | 11 |
| 2-5. | Return Loss from the ACX Antenna and Matching Circuit..... | 11 |
| 2-6. | Antenna Radiation Patterns | 12 |
| 2-7. | Host PCB Mating Connector Arrangement | 13 |
| 2-8. | Schematics of the CC3000 EM Board..... | 14 |
| 3-1. | Module Layout Guidelines..... | 16 |
| 3-2. | Module Layout Guidelines..... | 17 |
| 3-3. | Trace Design for the PCB Layout | 18 |
| 3-4. | Layer 1 Combined With Layer 2..... | 18 |
| 3-5. | Antenna and RF Trace Routing Layout Guidelines | 19 |
| 3-6. | Power Supply Routing of the CC3000 EM Board | 20 |
| 4-1. | MSP-EXP430FR5739 Test Platform and CC3000 EM Board | 21 |

List of Tables

| | | |
|------|--|----|
| 2-1. | Key Parts of CC3000 EM Board Top View | 7 |
| 2-2. | J2 Configuration of the CC3000 EM Board..... | 7 |
| 2-3. | Header J4 of the CC3000 EM Board Top View..... | 7 |
| 2-4. | Header J5 of the CC3000 EM Board Top View..... | 8 |
| 2-5. | Header J6 of CC3000 EM Board Bottom View | 9 |
| 2-6. | J7 of CC3000 EM Board Bottom View | 9 |
| 2-7. | BOM for the TI CC3000 EM Board..... | 15 |
| 3-1. | Module Layout Guidelines..... | 17 |
| 3-2. | Trace Design Measurement Values | 18 |
| 3-3. | Antenna and RF Trace Routing Layout Guidelines | 19 |

Read This First

About This Manual

This user guide describes how to use the TI CC3000 evaluation module (EM) board to evaluate the performance of the TI CC3000 module.

Related Documentation From Texas Instruments

- *TI SimpleLink™ CC3000 Module – Wi-Fi 802.11b/g Network Processor Data Sheet* (SWRS126)
- CC3000 Wiki for MCU: http://processors.wiki.ti.com/index.php/CC3000_Wi-Fi_for_MCU

If You Need Assistance

The primary sources of CC3000 information are the device-specific data sheets and user's guides. For the most up-to-date version of the user's guide and data sheets, go to <http://www.ti.com/product/cc3000>.

FCC Warning

This equipment is intended for use in a laboratory test environment only. It generates, uses, and can radiate radio frequency energy and has not been tested for compliance with the limits of computing devices pursuant to subpart J of part 15 of FCC rules, which are designed to provide reasonable protection against radio frequency interference. Operation of this equipment in other environments may cause interference with radio communications, in which case the user at his own expense will be required to take whatever measures may be required to correct this interference.

Introduction

This user guide describes how to use the TI CC3000 evaluation module (EM) board to evaluate the performance and functionality of the TI CC3000 module. The CC3000 module is a self-contained Wi-Fi® solution that enables internet connectivity for a wide variety of microcontroller (MCU) systems. The SimpleLink Wi-Fi from TI minimizes the host MCU software requirements, making it ideal for low-power and low-cost applications. The CC3000 EM board is targeted for TI MCUs, such as the MSP430-FR5739 and other various host platforms. This document details the key parts and features of the CC3000 EM board and the different options available to the user. This document includes layout guidelines to assist the designer in PCB development.

CC3000 EM Board

This section describes the key parts and features of the CC3000 EM board top and bottom views.

2.1 EM Board Top View

Figure 2-1 shows the key parts and jumpers mounted on the top of the CC3000 EM board. Table 2-1 describes the key parts of the EM board. Table 2-2 describes the J2 configuration of the CC3000 EM board. Table 2-3 and Table 2-4 describe the J4 and J5 signals, respectively.

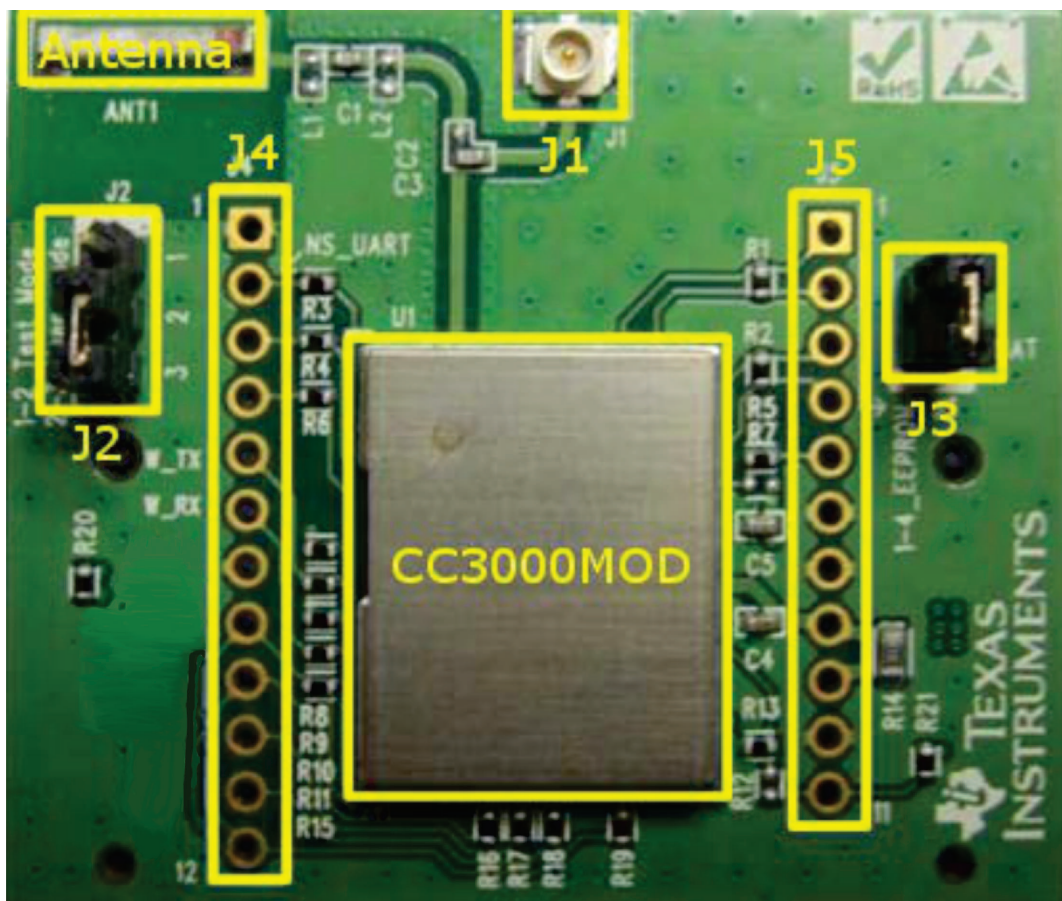

SWRU326-001

Figure 2-1. CC3000 EM Board Top View

Table 2-1. Key Parts of CC3000 EM Board Top View

| Key Parts | Descriptions |
|-----------|---|
| CC3000MOD | Core module for performance evaluation (for more information, see the CC3000 module data sheet). |
| Antenna | Can be used for radiated testing by reworking the capacitor to correct pads |
| J1 | U.FL RF connector used for conductive RF test |
| J2 | Used to switch between test mode and operation mode. When pins 2 and 3 are shorted, J2 runs in operation mode. When pins 1 and 2 are shorted, J2 runs in test mode. |
| J3 | Used to test power consumption. The pins of the jumper are shorted in operation mode. For power testing, the jumper is removed and an ammeter bridges the pins. |
| J4 | Through-hole test points (For more information, see Table 2-3.) |
| J5 | Through-hole test points (For more information, see Table 2-4.) |

Table 2-2. J2 Configuration of the CC3000 EM Board

| Mode | Description |
|---|--|
| Test mode: CC3000 radio tool ⁽¹⁾ | Connect pins 1 and 2. Test mode is used with the CC3000 radio tool for operating, testing, and calibrating the CC3000 chip-set designs during development. This tool uses the RS232/UART pins to run radio frequency (RF) RX and TX tests on the CC3000 module. For more information, see the CC3000 wiki. |
| Functional mode: Normal mode | Connect pins 2 and 3. Normal mode is for regular functionality between the host platform and the CC3000 module. |

⁽¹⁾ For more information about test software for the PC, go to the CC3000 wiki at http://processors.wiki.ti.com/index.php/CC3000_Wi-Fi_for_MCU.

Table 2-3. Header J4 of the CC3000 EM Board Top View

| J4 Pin | Pin Name | Pin Type | Descriptions |
|--------|-------------|----------|--|
| 1 | GND | – | Ground |
| 2 | Reserved | – | Reserved |
| 3 | Reserved | – | Reserved |
| 4 | Reserved | – | Reserved |
| 5 | WL_RS232_TX | Output | RS232 transmit output; used for the radio tool serial interface in test mode. Leave floating in functional mode. |
| 6 | WL_RS232_RX | Input | RS232 receive output; used for the radio tool serial interface in test mode. Leave floating in functional mode. |
| 7 | GND | – | Ground |
| 8 | WL_SPI_CS | Input | Host interface SPI chip select |
| 9 | WL_SPI_DOUT | Output | Host interface SPI data output |
| 10 | WL_SPI_IRQ | Output | Host interface SPI interrupt request |
| 11 | WL_SPI_DIN | Input | Host interface SPI data input |
| 12 | WL_SPI_CLK | Input | Host interface SPI clock input |

Table 2-4. Header J5 of the CC3000 EM Board Top View

| J5 Pin | Pin Name | Pin Type | Descriptions |
|--------|---------------------------|--------------|---|
| 1 | SCL_CC3000 ⁽¹⁾ | Output | I2C clock signal output from the CC3000 module. This pin is connected to SCL_EEPROM through a 0-Ω resistor and is not used by end users. |
| 2 | SCL_EEPROM ⁽¹⁾ | Input | I2C clock signal input from EEPROM inside the CC3000 module. This pin is connected to SCL_CC3000 using a 0-Ω resistor and is not used by end users. |
| 3 | SDA_CC3000 ⁽¹⁾ | Input/Output | I2C data signal from the CC3000 module. This pin is connected to SDA_EEPROM using a 0-Ω resistor and is not used by end users. |
| 4 | SDA_EEPROM ⁽¹⁾ | Input/Output | I2C data signal from EEPROM inside the CC3000 module. This pin is connected to the SDA_CC3000 device using a 0-Ω resistor and is not used by end users. |
| 5 | VBAT_SW_EN | Input | Active-high enables the signal from the host device. |
| 6 | GND | – | Ground |
| 7 | GND | – | Ground |
| 8 | VIO_HOST | Power In | VIO power supply from the host to the module. For the MSP430 host platform, VIO_HOST = VBAT_IN. For other platforms that have different voltage levels from battery voltages, R14 can be removed. |
| 9 | VBAT_IN | Power In | Battery voltage input to module. For the MSP430 host platform, VIO_HOST = VBAT_IN. For other platforms that have different voltage levels from the battery voltages, R14 can be removed. |
| 10 | GND | – | Ground |
| 11 | Reserved | – | Reserved |

⁽¹⁾ The EM board arrives with EEPROM preprogrammed.

2.2 EM Board Bottom View

The two EM board mating connectors J6 and J7 connect to the host platform and are mounted on the bottom of the EM board, as shown in [Figure 2-2](#). [Table 2-5](#) and [Table 2-6](#) describe the signals brought out from these two EM mating connectors.

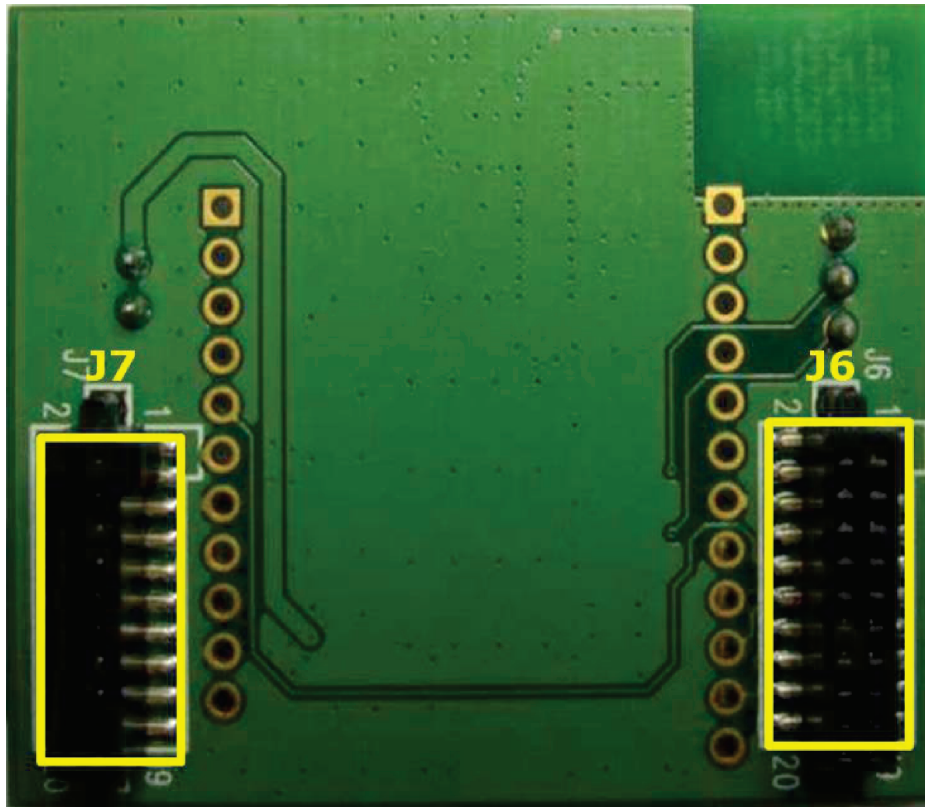

SWRU326-002

Figure 2-2. CC3000 EM Board Bottom View

Table 2-5. Header J6 of CC3000 EM Board Bottom View

| J6 Pin | Pin Name | Module Pin Type | Description |
|--------|-------------|-----------------|--|
| 1 | GND | – | Ground |
| 5 | Reserved | – | Reserved |
| 10 | VBAT_SW_EN | Input | Active-high enable signal from the host device |
| 12 | WL_SPI_IRQ | Output | Host interface SPI interrupt request |
| 14 | WL_SPI_CS | Input | Host interface SPI CS |
| 16 | WL_SPI_CLK | Input | Host interface SPI clock input |
| 18 | WL_SPI_DIN | Input | Host Interface SPI data input |
| 19 | GND | – | Ground |
| 20 | WL_SPI_DOUT | Output | Host interface SPI data output |

Table 2-6. J7 of CC3000 EM Board Bottom View

| J7 Pin | Pin Name | Module Pin Type | Description |
|--------|----------|-----------------|-------------------------------------|
| 2 | GND | – | Ground |
| 7 | VBAT_IN | Power In | Battery voltage input to the module |
| 9 | VBAT_IN | Power In | Battery voltage input to the module |
| 15 | Reserved | – | Reserved |

2.3 Antenna

The ACX ceramic antenna is mounted on the EM board with a specific layout and matching circuit for the radiation tests conducted in FCC, CE, and IC certifications. [Figure 2-3](#) shows the location of the ACX ceramic antenna on the EM board and the RF trace routing from the CC3000 module to the antenna. [Figure 2-4](#) shows the matching circuit between the antenna and the EM board. The return loss is based on the matching circuit and RF trace routing, as shown in [Figure 2-5](#). [Figure 2-6](#) shows the radiation patterns on XY, XZ, and YZ planes.

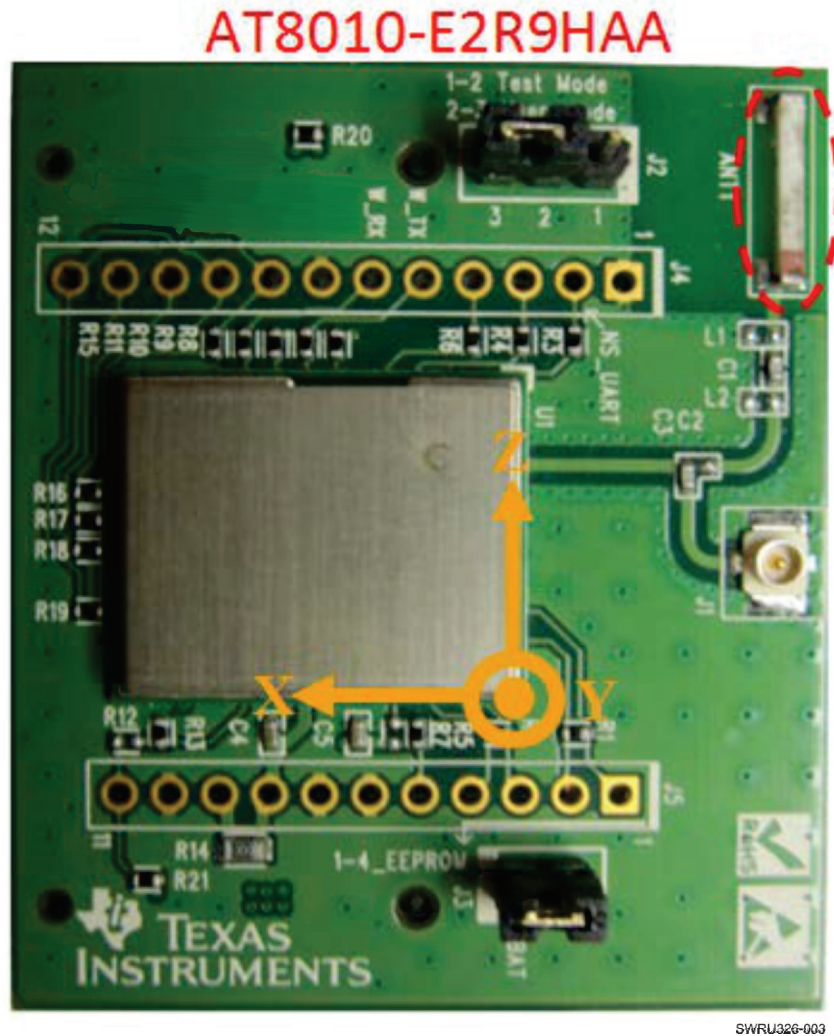
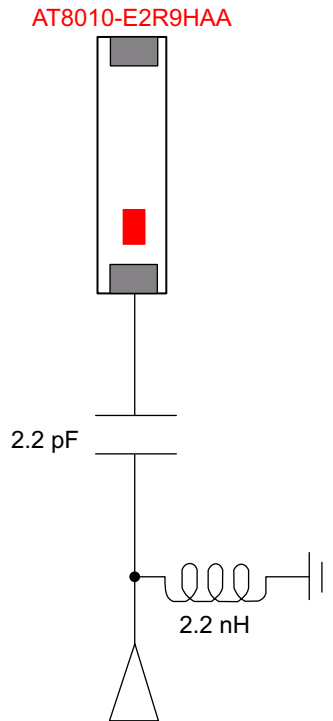
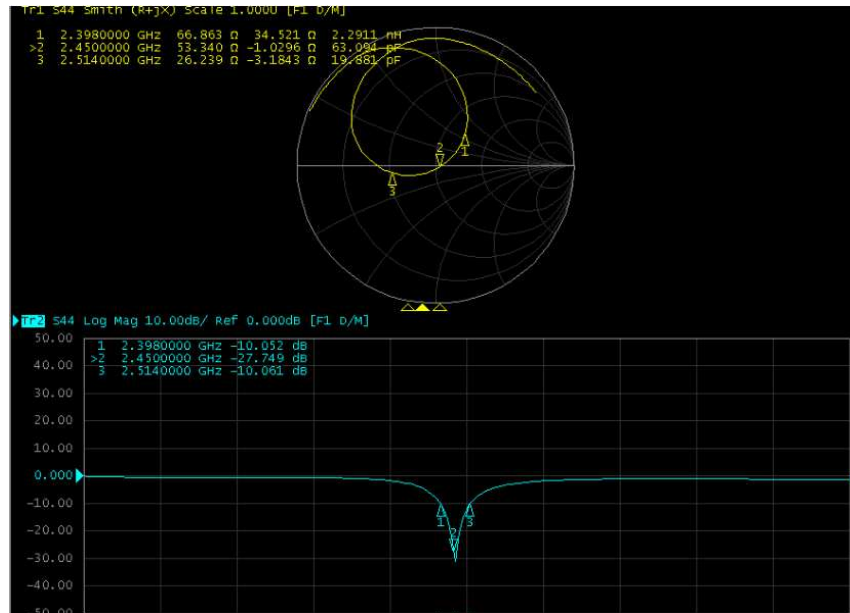

Figure 2-3. Antenna Location and RF Trace Routing



SWRU326-004

Figure 2-4. Matching Circuit Between the Antenna and the CC3000 EM Board



SWRU326-005

Figure 2-5. Return Loss from the ACX Antenna and Matching Circuit

XY plane

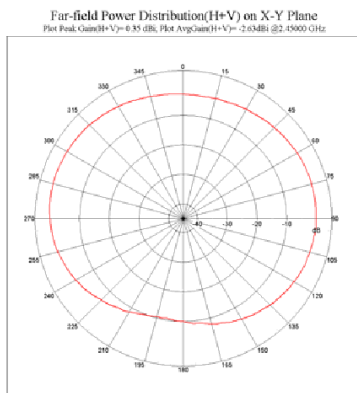

Unit : dBi

| | Peak gain | Avg. gain |
|----------|-----------|-----------|
| XY plane | 0.3 | -2.6 |

XZ plane

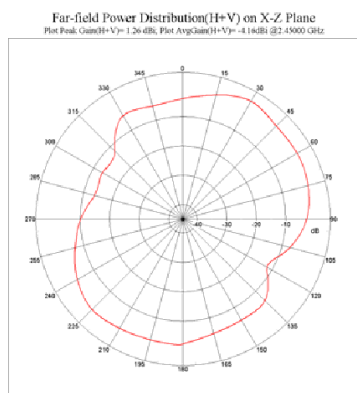

| | Peak gain | Avg. gain |
|----------|-----------|-----------|
| XZ plane | 1.3 | -4.2 |

YZ plane

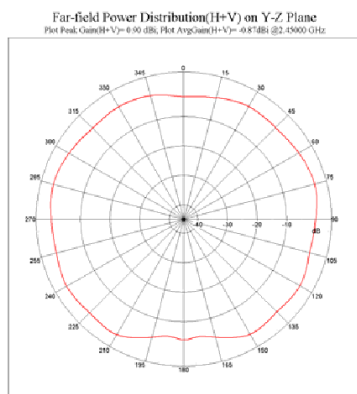

| | Peak gain | Avg. gain |
|----------|-----------|-----------|
| YZ plane | 0.9 | -0.9 |

SWRU326-006

Figure 2-6. Antenna Radiation Patterns

2.4 Hardware Setup

Before conducting performance tests, the EM board must be connected to the host platform, either with the mating connectors (J6 and J7) or the single-row headers (J4 and J5). To use the EM mating connectors to connect the hardware, the mating EM connector must be lined up and spaced 1.2 inches apart (see [Figure 2-7](#)). To use the single-row headers, the required signals from the EM mating connectors must be wired to the host platform.

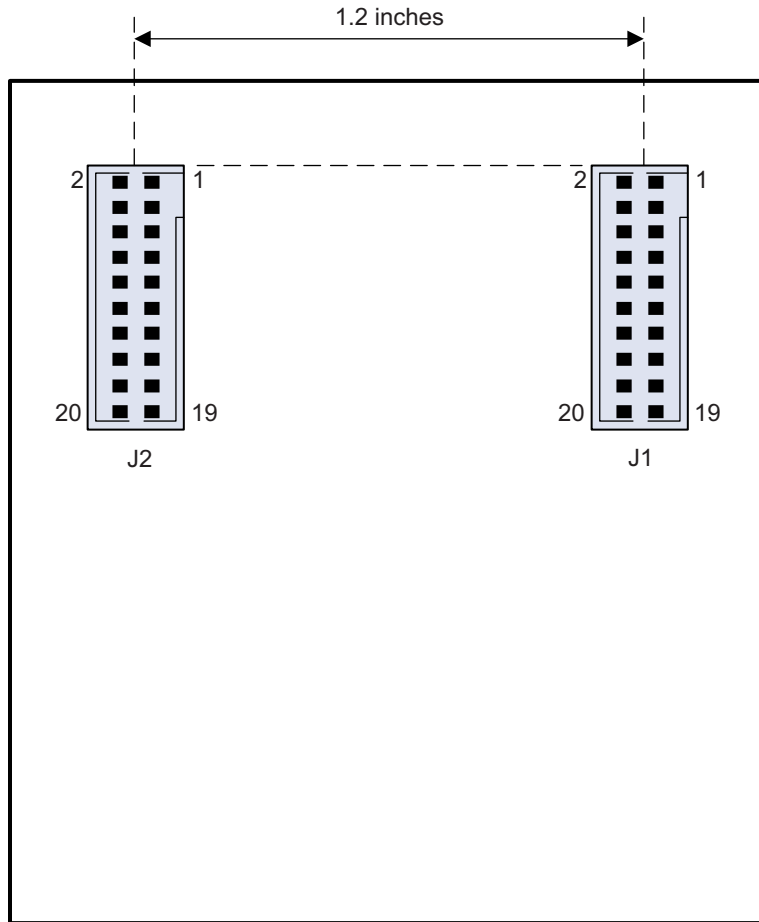

SWRU326-007

Figure 2-7. Host PCB Mating Connector Arrangement

2.5 Schematics

Figure 2-8 shows the schematics of the CC3000 EM board.

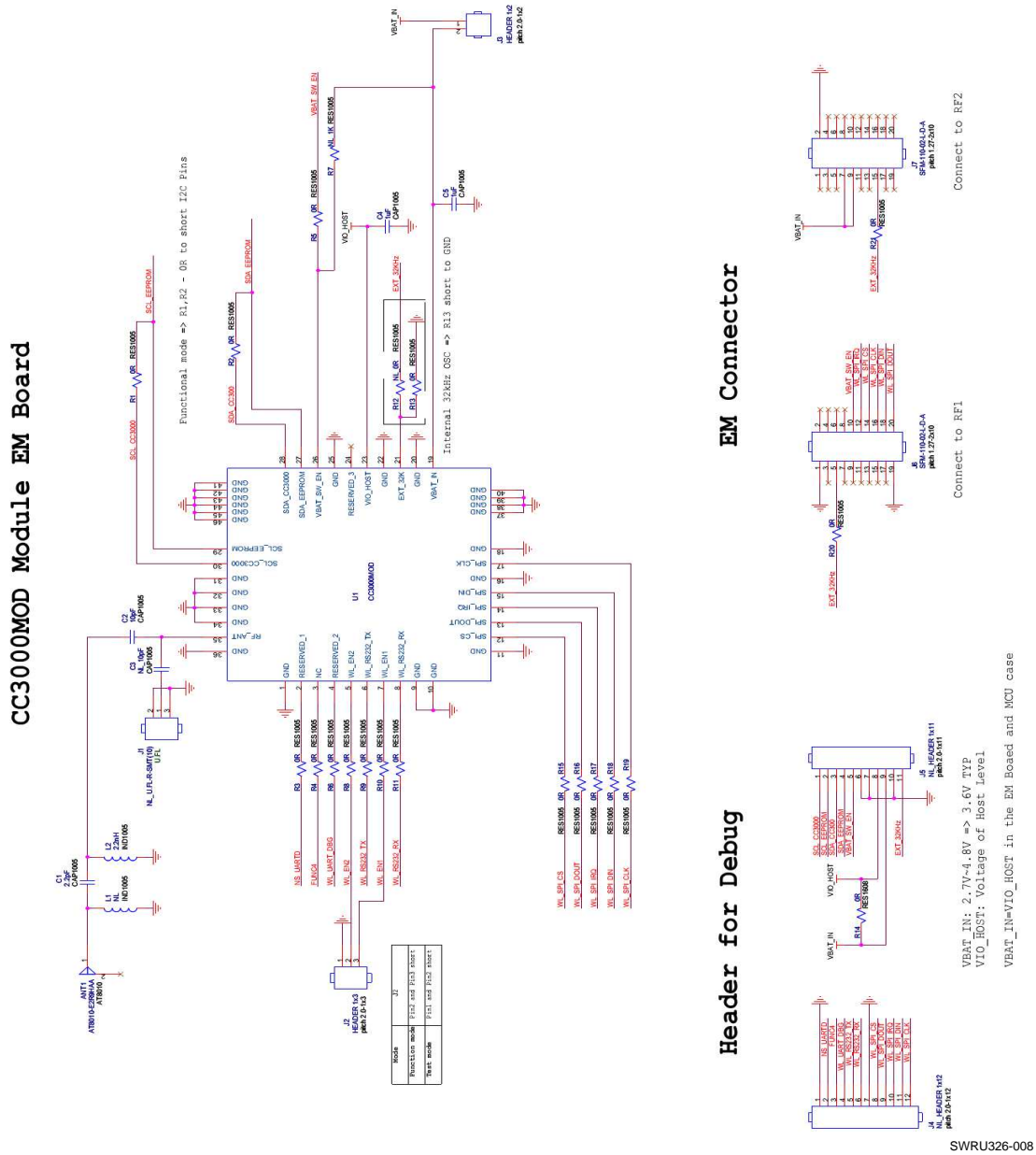

Figure 2-8. Schematics of the CC3000 EM Board

2.6 Bill of Materials (BOM)

Table 2-7 lists the BOM for the TI CC3000 EM board.

Table 2-7. BOM for the TI CC3000 EM Board

| Items | Reference Designator | Description |
|-------|--|---|
| 1 | U1 | TI CC3000 Wi-Fi b/g module (BM) |
| 2 | ANT1 | ANT, 2.4 GHz, peak gain 2.5 dB |
| 3 | J1 | Mini RF header receptacle |
| 4 | J2 | CON male 1 x 3, pitch 2.0 mm |
| 5 | J3 | CON male 1 x 2, pitch 2.0 mm |
| 6 | J6,J7 | Female header, Fool Proof H:4.3, 2 x 10, pitch 1.27 mm, SMT |
| 7 | C1,C3 | CAP 0402 10 pF, 50 V, NPO, $\pm 5\%$ |
| 8 | C4,C5 | CAP 0402 1 μ F, X5R, 6.3 V, $\pm 10\%$, HF |
| 9 | R1, R2, R3, R4, R5, R6, R8, R9, R10, R11, R13, R15, R16, R17, R18, R19, R20, R21 | RES 0402, 0- Ω jumper |
| 10 | R14 | RES 0603, 0- Ω jumper |

Layout Guidelines

This section presents guidelines that must be followed when creating a board design incorporating the TI CC3000 module.

Figure 3-1 shows the TI CC3000 EM four-layer board. Table 3-1 and Figure 3-2 describe instances of good layout practices.

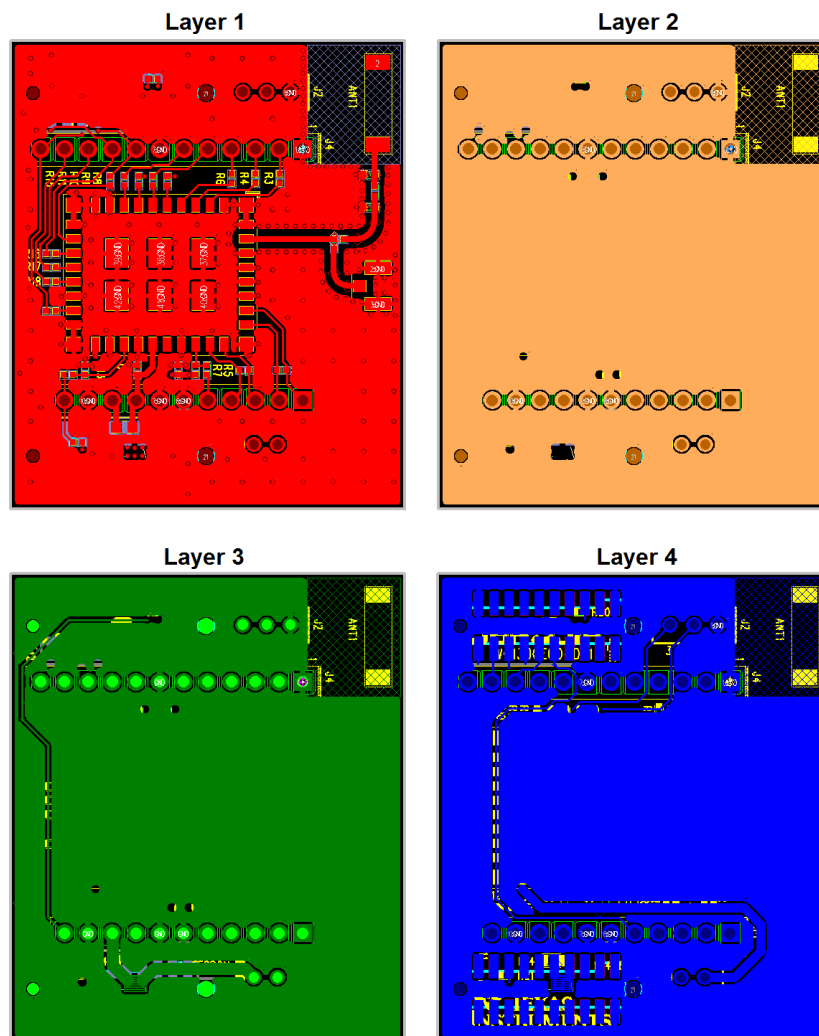

SWRU326-014

Figure 3-1. Module Layout Guidelines

Table 3-1. Module Layout Guidelines

| Reference ⁽¹⁾ | Guideline Description |
|--------------------------|---|
| 1 | The proximity of ground vias must be close to the pad. |
| 2 | Signal traces must not be run underneath the module on the layer where the module is mounted. |
| 3 | Have a complete ground pour in layer 2 for thermal dissipation. |
| 4 | Have a solid ground plane and ground vias under the module for stable system and thermal dissipation. |
| 5 | Increase the ground pour in the first layer and have all of the traces from the first layer on the inner layers, if possible. |
| 6 | Signal traces can be run on a third layer under the solid ground layer, which is below the module mounting layer. |

⁽¹⁾ See [Figure 3-2](#).

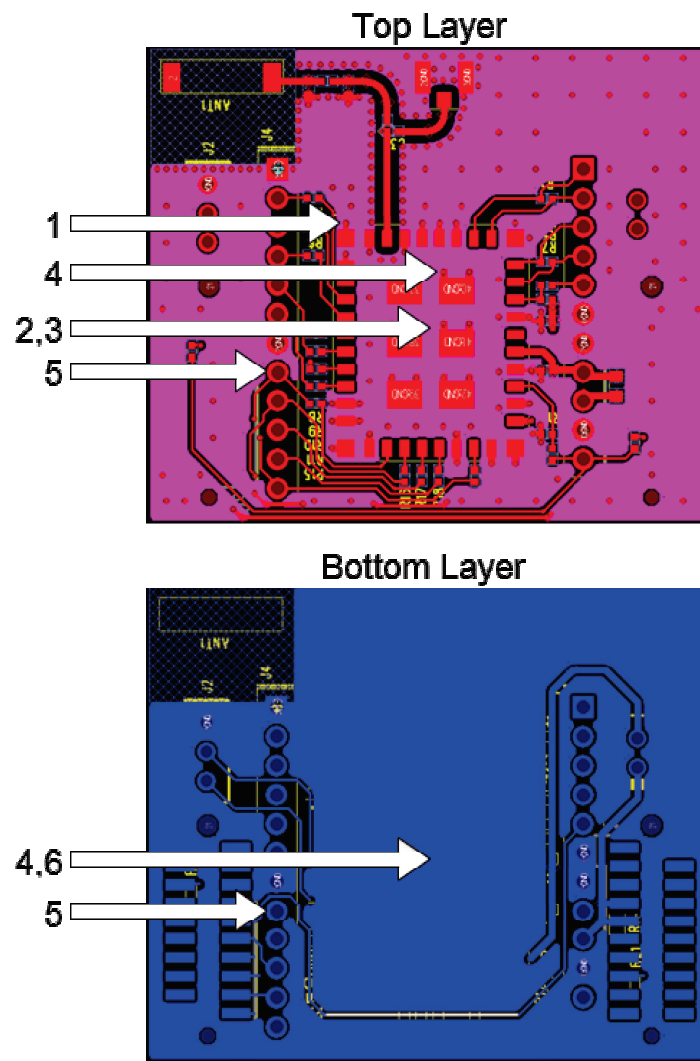

SWRU326-013

Figure 3-2. Module Layout Guidelines

[Figure 3-3](#) shows the trace design for the PCB. A 50-Ω impedance match on the trace to the antenna should be used. Also, 50-Ω traces are recommended for the PCB layout. [Table 3-2](#) lists the distances shown in [Figure 3-3](#). [Figure 3-4](#) shows layer 1 with the trace to the antenna over ground layer 2. [Table 3-3](#) and [Figure 3-5](#) describe instances of good layout practices for the antenna and RF trace routing.

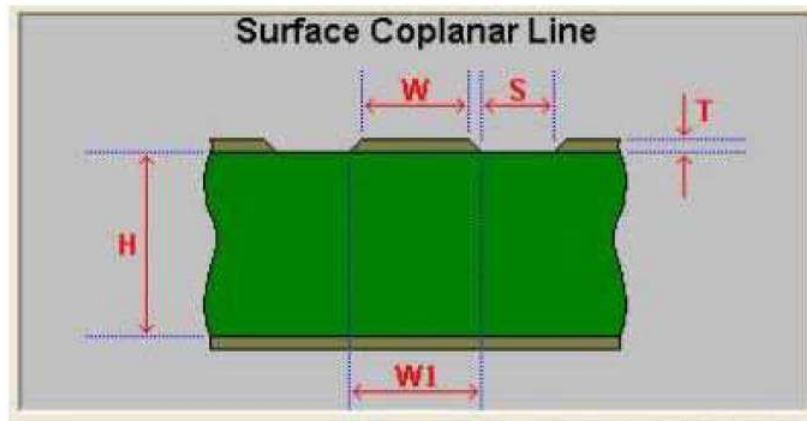

SWRU326-010

Figure 3-3. Trace Design for the PCB Layout

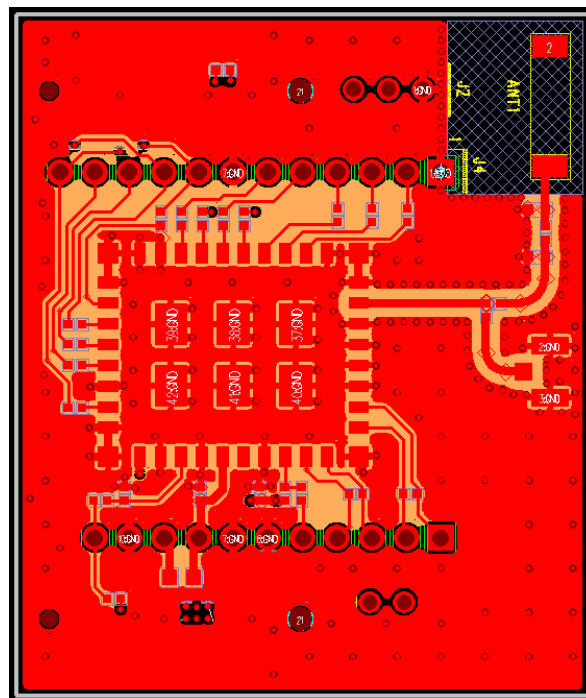

SWRU326-015

Figure 3-4. Layer 1 Combined With Layer 2

Table 3-2. Trace Design Measurement Values

| Measurement | Length |
|------------------------------|----------|
| H (height between L1 and L2) | 12.0 mil |
| W (RF trace) | 14.3 mil |
| T (thickness) | 1.2 mil |
| S (separation) | 10.0 mil |
| ϵ_r (dielectric) | 4.3 |

Table 3-3. Antenna and RF Trace Routing Layout Guidelines

| Reference ⁽¹⁾ | Guideline Description |
|--------------------------|---|
| 1 | The RF trace antenna feed must be as short as possible beyond the ground reference. At this point, the trace starts to radiate. |
| 2 | The RF trace bends must be gradual with an approximate maximum bend of 45 degrees with trace mitered. RF traces must not have sharp corners. |
| 3 | RF traces must have via stitching on the ground plane beside the RF trace on both sides. |
| 4 | RF traces must have constant impedance (microstrip transmission line). |
| 5 | For best results, the RF trace ground layer must be the ground layer immediately below the RF trace. The ground layer must be solid. |
| 6 | There must be no traces or ground under the antenna section. |
| 7 | The PCB designer must understand the microstrip model used and the scale line width according to the microstrip model. |
| 8 | RF traces must be as short as possible. The antenna, RF traces, and modules must be on the edge of the PCB product. The proximity of the antenna to the enclosure and the enclosure material must also be considered. |

⁽¹⁾ See Figure 3-5.

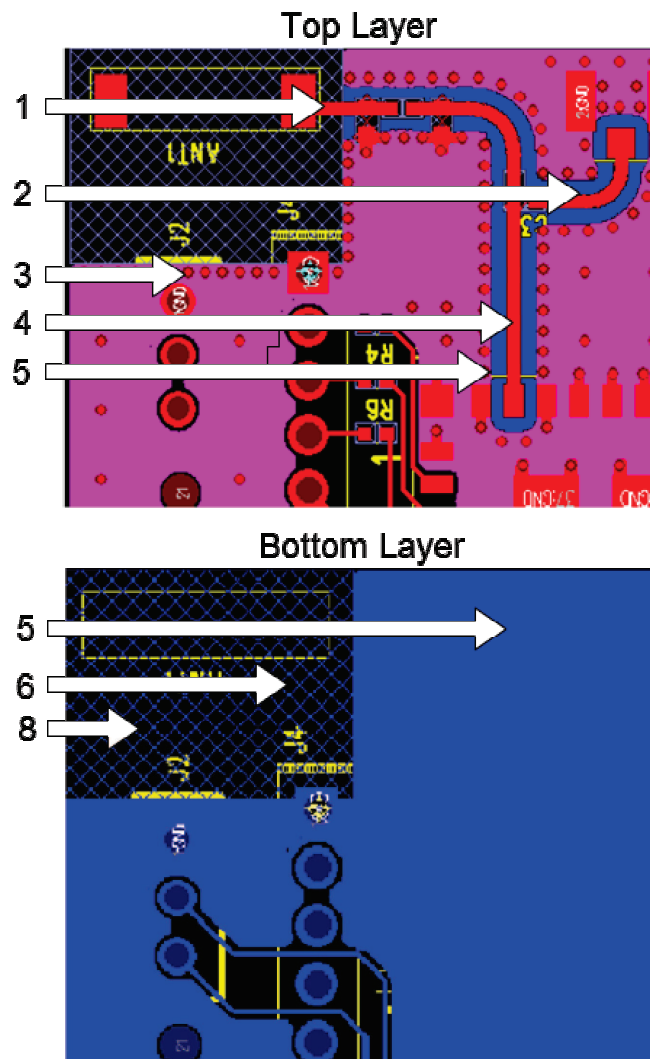

SWRU326-011

Figure 3-5. Antenna and RF Trace Routing Layout Guidelines

Figure 3-6 shows the supply routing guidelines:

- For power supply routing, the power trace for VBAT must be at least 40 mil wide.
- The 1.8-V trace must be at least 18 mil wide.
- Make VBAT traces as wide as possible to ensure reduced inductance and trace resistance.
- If possible, shield VBAT traces with ground above, below, and beside the traces.

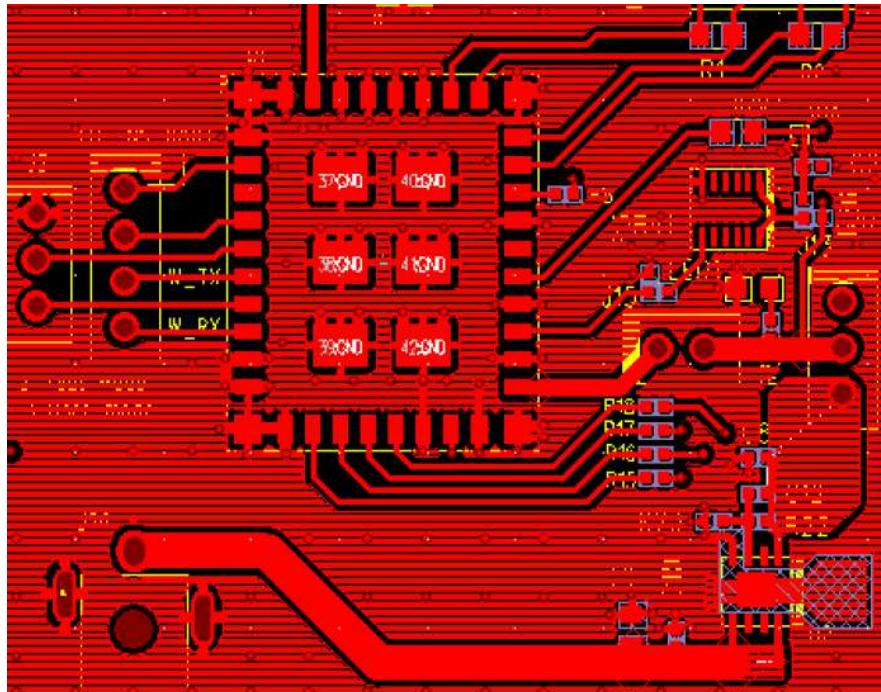

SWRU326-012

Figure 3-6. Power Supply Routing of the CC3000 EM Board

Application Development

TI supports the CC3000 EM board when paired with the following TI MCU host platforms:

- MSP-EXP430FR5739
- MSP-EXP430F5529
- MSP-EXP430F5438
- MSP-EXP430FG4618
- DK-LM3S9B96
- EK-LM4F232

To find example applications for each of the listed host platforms, go to the TI wiki at: http://processors.wiki.ti.com/index.php/CC3000_Wi-Fi_for_MCU#TI_Platforms.

In addition to the TI MCU platforms, the CC3000 EM board can be used on other platforms with the same RF connector interface. For a host driver porting guide to assist with porting to other platforms, go to http://processors.wiki.ti.com/index.php/CC3000_Host_Driver_Porting_Guide.

Figure 4-1 shows the MSP-EXP430FR5739 test platform and CC3000 EM board.

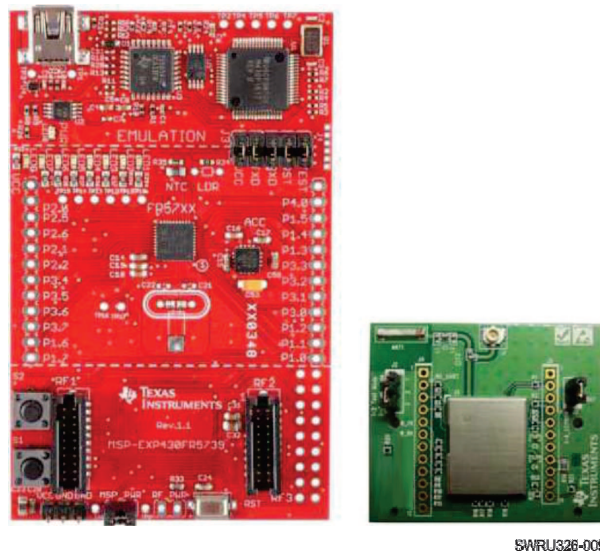

Figure 4-1. MSP-EXP430FR5739 Test Platform and CC3000 EM Board

IMPORTANT NOTICE

Texas Instruments Incorporated and its subsidiaries (TI) reserve the right to make corrections, enhancements, improvements and other changes to its semiconductor products and services per JESD46, latest issue, and to discontinue any product or service per JESD48, latest issue. Buyers should obtain the latest relevant information before placing orders and should verify that such information is current and complete. All semiconductor products (also referred to herein as "components") are sold subject to TI's terms and conditions of sale supplied at the time of order acknowledgment.

TI warrants performance of its components to the specifications applicable at the time of sale, in accordance with the warranty in TI's terms and conditions of sale of semiconductor products. Testing and other quality control techniques are used to the extent TI deems necessary to support this warranty. Except where mandated by applicable law, testing of all parameters of each component is not necessarily performed.

TI assumes no liability for applications assistance or the design of Buyers' products. Buyers are responsible for their products and applications using TI components. To minimize the risks associated with Buyers' products and applications, Buyers should provide adequate design and operating safeguards.

TI does not warrant or represent that any license, either express or implied, is granted under any patent right, copyright, mask work right, or other intellectual property right relating to any combination, machine, or process in which TI components or services are used. Information published by TI regarding third-party products or services does not constitute a license to use such products or services or a warranty or endorsement thereof. Use of such information may require a license from a third party under the patents or other intellectual property of the third party, or a license from TI under the patents or other intellectual property of TI.

Reproduction of significant portions of TI information in TI data books or data sheets is permissible only if reproduction is without alteration and is accompanied by all associated warranties, conditions, limitations, and notices. TI is not responsible or liable for such altered documentation. Information of third parties may be subject to additional restrictions.

Resale of TI components or services with statements different from or beyond the parameters stated by TI for that component or service voids all express and any implied warranties for the associated TI component or service and is an unfair and deceptive business practice. TI is not responsible or liable for any such statements.

Buyer acknowledges and agrees that it is solely responsible for compliance with all legal, regulatory and safety-related requirements concerning its products, and any use of TI components in its applications, notwithstanding any applications-related information or support that may be provided by TI. Buyer represents and agrees that it has all the necessary expertise to create and implement safeguards which anticipate dangerous consequences of failures, monitor failures and their consequences, lessen the likelihood of failures that might cause harm and take appropriate remedial actions. Buyer will fully indemnify TI and its representatives against any damages arising out of the use of any TI components in safety-critical applications.

In some cases, TI components may be promoted specifically to facilitate safety-related applications. With such components, TI's goal is to help enable customers to design and create their own end-product solutions that meet applicable functional safety standards and requirements. Nonetheless, such components are subject to these terms.

No TI components are authorized for use in FDA Class III (or similar life-critical medical equipment) unless authorized officers of the parties have executed a special agreement specifically governing such use.

Only those TI components which TI has specifically designated as military grade or "enhanced plastic" are designed and intended for use in military/aerospace applications or environments. Buyer acknowledges and agrees that any military or aerospace use of TI components which have **not** been so designated is solely at the Buyer's risk, and that Buyer is solely responsible for compliance with all legal and regulatory requirements in connection with such use.

TI has specifically designated certain components which meet ISO/TS16949 requirements, mainly for automotive use. Components which have not been so designated are neither designed nor intended for automotive use; and TI will not be responsible for any failure of such components to meet such requirements.

Products

| | |
|------------------------------|--|
| Audio | www.ti.com/audio |
| Amplifiers | amplifier.ti.com |
| Data Converters | dataconverter.ti.com |
| DLP® Products | www.dlp.com |
| DSP | dsp.ti.com |
| Clocks and Timers | www.ti.com/clocks |
| Interface | interface.ti.com |
| Logic | logic.ti.com |
| Power Mgmt | power.ti.com |
| Microcontrollers | microcontroller.ti.com |
| RFID | www.ti-rfid.com |
| OMAP Applications Processors | www.ti.com/omap |
| Wireless Connectivity | www.ti.com/wirelessconnectivity |

Applications

| | |
|-------------------------------|--|
| Automotive and Transportation | www.ti.com/automotive |
| Communications and Telecom | www.ti.com/communications |
| Computers and Peripherals | www.ti.com/computers |
| Consumer Electronics | www.ti.com/consumer-apps |
| Energy and Lighting | www.ti.com/energy |
| Industrial | www.ti.com/industrial |
| Medical | www.ti.com/medical |
| Security | www.ti.com/security |
| Space, Avionics and Defense | www.ti.com/space-avionics-defense |
| Video and Imaging | www.ti.com/video |
| TI E2E Community | e2e.ti.com |