

**SPECIFICATION  
FOR  
LCD Module  
KD035C-10F**

<b>MODULE:</b>	<b>KD035C-10F</b>
<b>CUSTOMER:</b>	

<b>REV</b>	<b>DESCRIPTION</b>	<b>DATE</b>
<b>1.0</b>	<b>FIRST ISSUE</b>	<b>2014.07.10</b>

<b>STARTEK</b>	<b>INITIAL</b>	<b>DATE</b>
<b>PREPARED BY</b>		
<b>CHECKED BY</b>		
<b>APPROVED BY</b>		

<b>CUSTOMER</b>	<b>INITIAL</b>	<b>DATE</b>
<b>APPROVED BY</b>		



## Contents

General Description	4
1. Block Diagram	5
2. Outline dimension	6
3. Input Terminal Pin Assignment	7
4. LCD Optical Characteristics	9
5. Electrical Characteristics	11
6. AC Characteristic	13
7. Waveform	14
8. LCD Module Out-Going Quality Level	18
9. Reliability Test Result	26
10. Cautions and Handling Precautions	27
11. Packing	28

## General Description

### \* Description

This is a color active matrix TFT (Thin Film Transistor) LCD (liquid crystal display) that uses amorphous silicon TFT as a switching device. This model is composed of a Transmissive type TFT-LCD Panel, driver circuit, back-light unit. The resolution of a 3.5" TFT-LCD contains 320X240pixels, and can display up to 16.7M colors.

### \* Features

-Input Voltage: 3.3V

-Display Colors of TFT LCD: 65K/262K/16.7M colors

-RGB Interface: 16/18/24 Bit RGB SYNC Mode

General Information Items	Specification	Unit	Note
	Main Panel		
Display area(AA)	70.08(H) *52.56(V) (3.5inch )	mm	-
Driver element	TFT active matrix	-	-
Display colors	16.7M	colors	-
Number of pixels	320(RGB) *240	dots	-
Pixel arrangement	RGB vertical stripe	-	-
Pixel pitch	0.066 (H) x 0.198 (V)	mm	-
Viewing angle	ALL	o'clock	-
Controller IC	HX8238D	-	-
Display mode	Transmissive/ Normally White	-	-
Operating temperature	-20~+70	°C	-
Storage temperature	-30~+80	°C	-

### \* Mechanical Information

Item		Min.	Typ.	Max.	Unit	Note
Module size	Horizontal(H)		76.84		mm	-
	Vertical(V)		63.84		mm	-
	Depth(D)		3.27		mm	-
Weight			TBD		g	-

1. Block Diagram

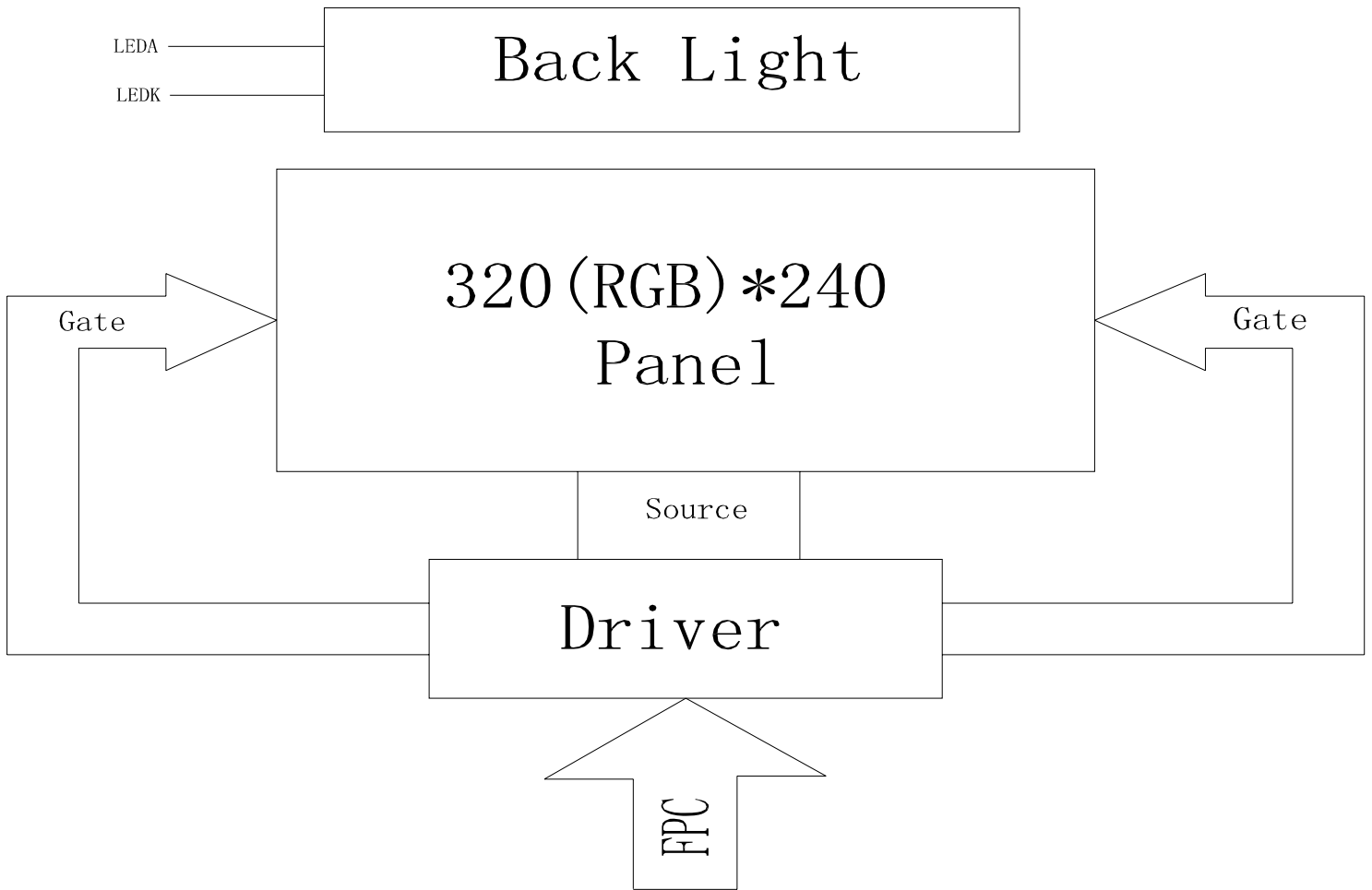

## 2. Outline dimension

注:上机壳开窗须小于 UP POL 0.3mm以上

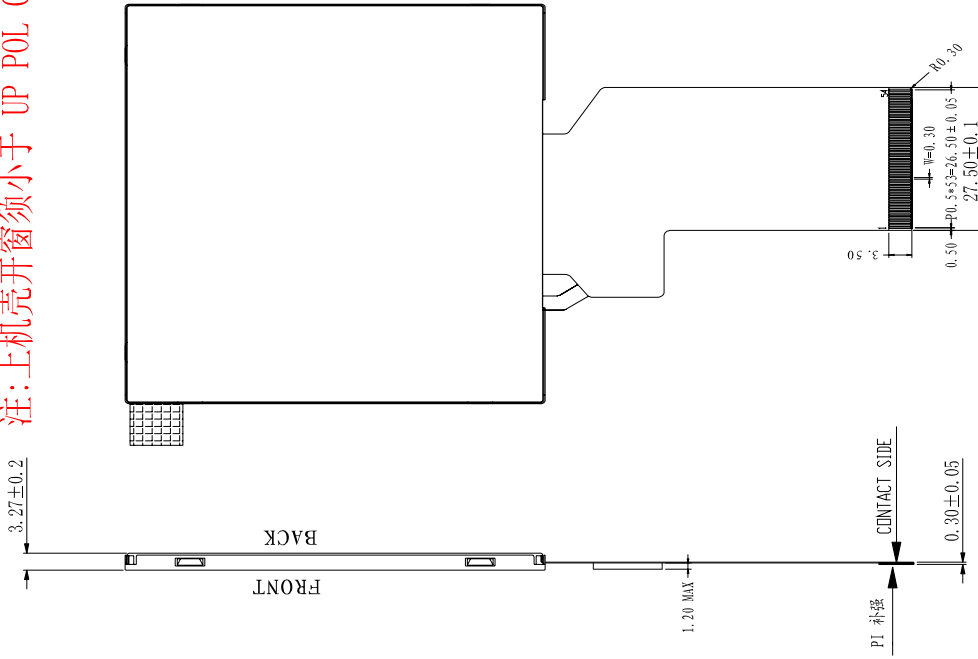
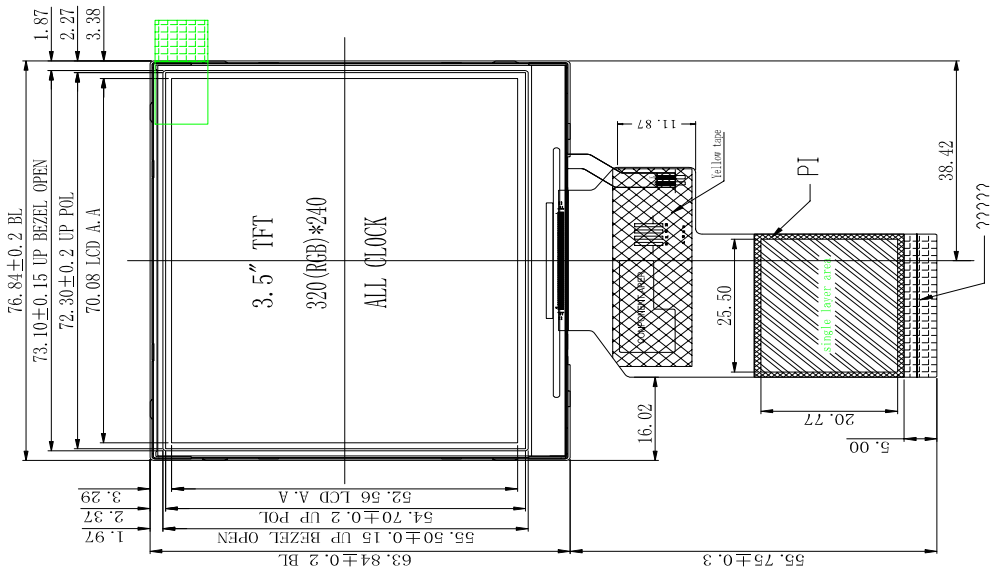

NO.	Pin Name
1	VBL+
2	VBL-
3	VBL+
4	VBL+
5	VU
6	VR
7	NC
8	RESSET
9	CS
10	SCX
11	SRI
12	B1
13	B1
14	B2
15	B3
16	B4
17	B5
18	B6
19	B7
20	G1
21	G1
22	G2
23	G3
24	G4
25	G5
26	G6
27	G7
28	R0
29	R1
30	R2
31	R3
32	R4
33	R5
34	R6
35	R7
36	HSYNC
37	VSYNC
38	DCLK
39	NC
40	NC
41	VDD
42	VDD
43	V0
44	V0
45	NC
46	NC
47	NC
48	SE2
49	SE1
50	SE0
51	NC
52	DE
53	GND
54	GND

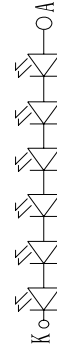

B/L Circuit

深圳市柯达电子科技有限公司  
Shenzhen Startek Electronic Technology Co., Ltd

ReV	Revision content description	Date
V0	FIRST	2014/05/23

TOLERANCE(公差)	DRAWING NAME	Unit
TOLERANCE UNLESS	Drawn	mm
OTHERWISE SPECIFIED	Checked	mm
Scale 1:1	Approve	Page 1/1

- NOTES:
1. DISPLAY TYPE: 3.5", TFT-LCD, 65K/262K/16.7M COLORS
  2. DISPLAY MODE: T/M NORMALLY WHITE
  3. VIEWING DIRECTION: ALL
  4. DRIVER IC: HX8238D (COG)
  5. INTERFACE: 16BIT/18BIT/24BIT-RGB
  6. VCI: 3.3V(TYP)
  7. OPERATING TEMP: -20°C TO 70°C  
STORAGE TEMP: -30°C TO 80°C
  8. BACK LIGHT: LED WHITE, 6 LED, 20mA, 18.6±0.3V
  9. RoHS COMPLIANT.

### 3. Input terminal Pin Assignment

NO.	SYMBOL	DISCRIPTION	I/O
1	BLK	Cathode pin OF backlight	P
2	BLK	Cathode pin OF backlight	P
3	BLA	Anode pin of backlight	P
4	BLA	Anode pin of backlight	P
5	YU(NC)	Touch panel Top Film Terminal	
6	XR(NC)	Touch panel Right Glass Terminal	
7	NC		
8	RESET	System reset pin. Internal pull high. -Connect to VDDIO when not used.	I
9	CSB	Chip select pin of serial interface. Internal pull high. -Leave it open when not used.	I
10	SCK	Clock pin of serial interface. Internal pull high. -Leave it open when not used.	I
11	SDI	Date input pin of serial interface. Internal pull high. -Leave it open when not used.	I
12-19	B0-B7	Blue data input.	I
20-27	G0-G7	Green data input.	I
28-35	R0-R7	Red data input.	I
36	HSYNC	Horizontal Sync input. Negative polarity.	I
37	VSYNC	Vertical Sync input. Negative polarity.	I
38	DCLK	Clock signal. Latching data at the rising edge	I
39	NC		
40	NC		
41	VDD	Supply voltage(3.3V).	P
42	VDD	Supply voltage(3.3V).	P

43	YD(NC)	Touch panel Bottom Film Terminal	
44	XL(NC)	Touch panel LIFT Glass Terminal	
45-47	NC		
48	SEL2	Input pin to select input interface mode.	I
49	SEL1	Input pin to select input interface mode.	I
50	SEL0	Input pin to select input interface mode.	I
51	NC		
52	DE	Data input Enable. Active High to enable the data input Bus under "DE Mode". -if used SYNC mode Leave it open when not used.	I
53	GND	Ground.	P
54	GND	Ground.	P



## 4. LCD Optical Characteristics

### 2.1 Optical specification

Item	Symbol	Conditions	Specifications			Unit	Note	
			Min.	Typ.	Max.			
Transmittance	T%	Viewing normal angle $\theta_x = \theta_y = 0^\circ$	3.0			%	All left side data are based on CMO's following condition -T6 NTSC: 60% LC:5091 Light : C light (Machine:BM5A) Normal Polarizer Without DBEF <b>“Simulation Data Reference Only”</b>	
Contrast Ratio	CR		500	700		--		
Response Time	$T_R$			15	30	ms		
	$T_F$			35	50	ms		
Chromaticity	Red		$X_R$	0.609	0.639	0.669		
			$Y_R$	0.314	0.344	0.374		
	Green		$X_G$	0.264	0.294	0.324		
			$Y_G$	0.557	0.587	0.617		
	Blue		$X_B$	0.102	0.132	0.162		
			$Y_B$	0.106	0.136	0.166		
	White	$X_W$	0.282	0.312	0.342			
		$Y_W$	0.319	0.349	0.379			
Viewing Angle	Hor.	$\theta_{x+}$		80		deg.		
		$\theta_{x-}$		80				
	Ver.	$\theta_{y+}$		80				
		$\theta_{y-}$		80				

Note (1) Definition of Contrast Ratio (CR):

The contrast ratio can be calculated by the following expression.

$$\text{Contrast Ratio (CR)} = L_{63} / L_0$$

L63: Luminance of gray level 63

L 0: Luminance of gray level 0

$$CR = CR(10)$$

CR (X) is corresponding to the Contrast Ratio of the point X at Figure in Note (5).

Note (2) Definition of Response Time ( $T_R$ ,  $T_F$ ):

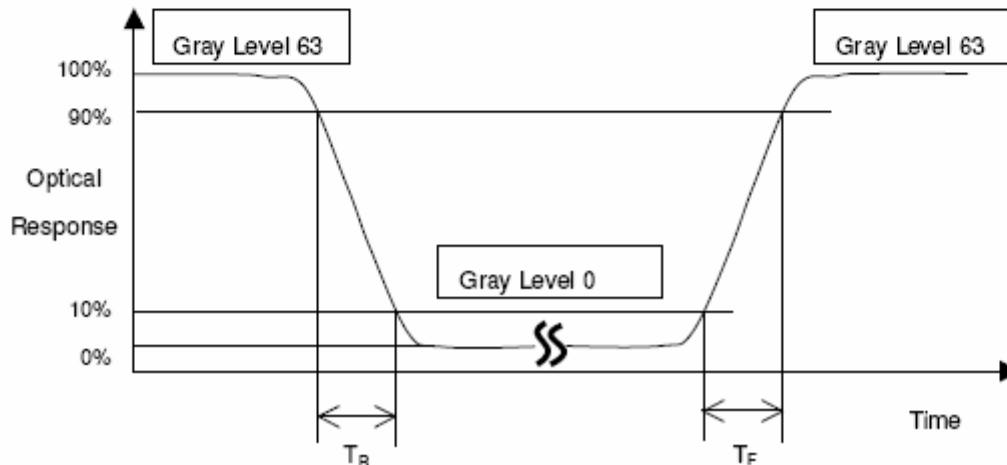

\*Note(3) Definition of Viewing Angle

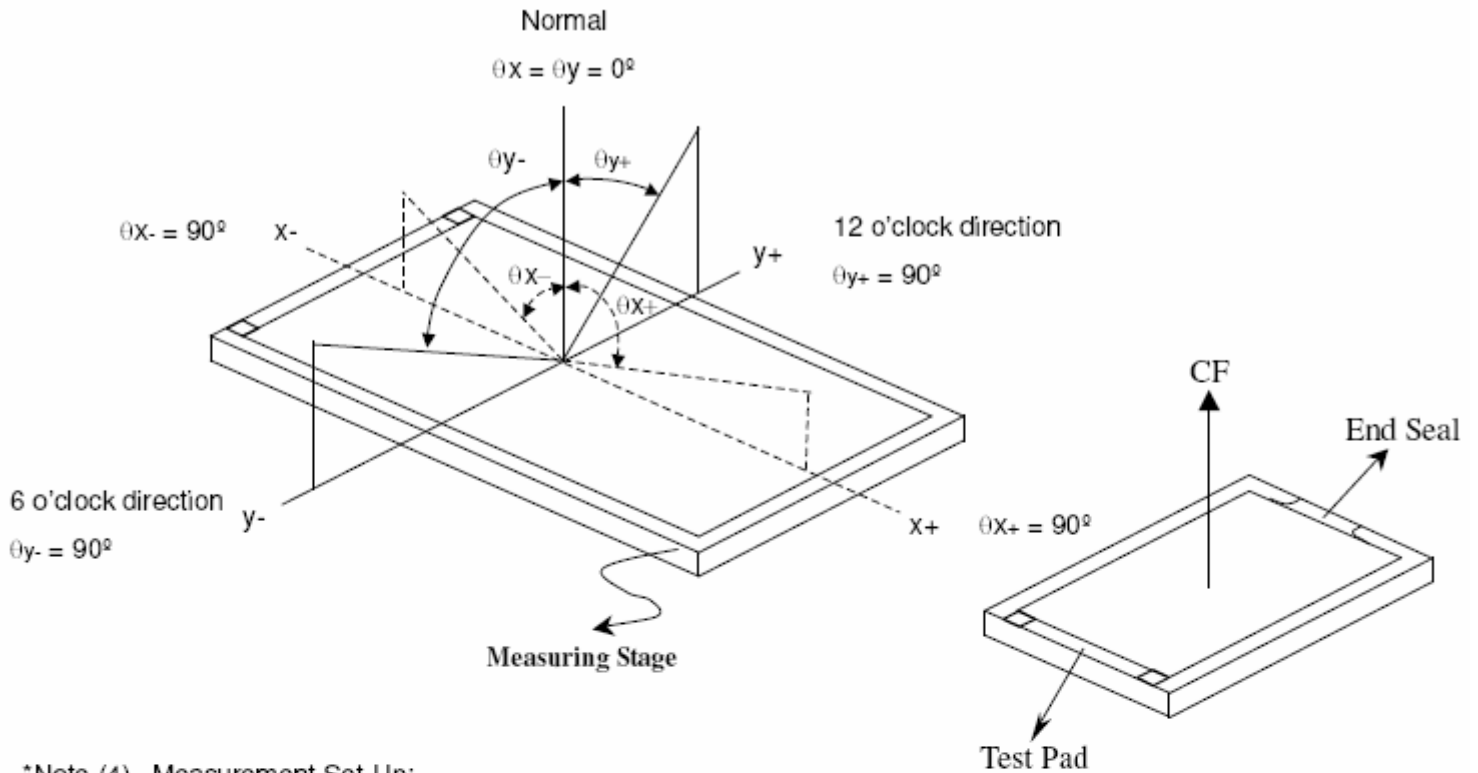

\*Note (4) Measurement Set-Up:

The LCD module should be stabilized at a given temperature for 20 minutes to avoid abrupt temperature change during measuring. In order to stabilize the luminance, the measurement should be executed after lighting Backlight for 20 minutes in a windless room.

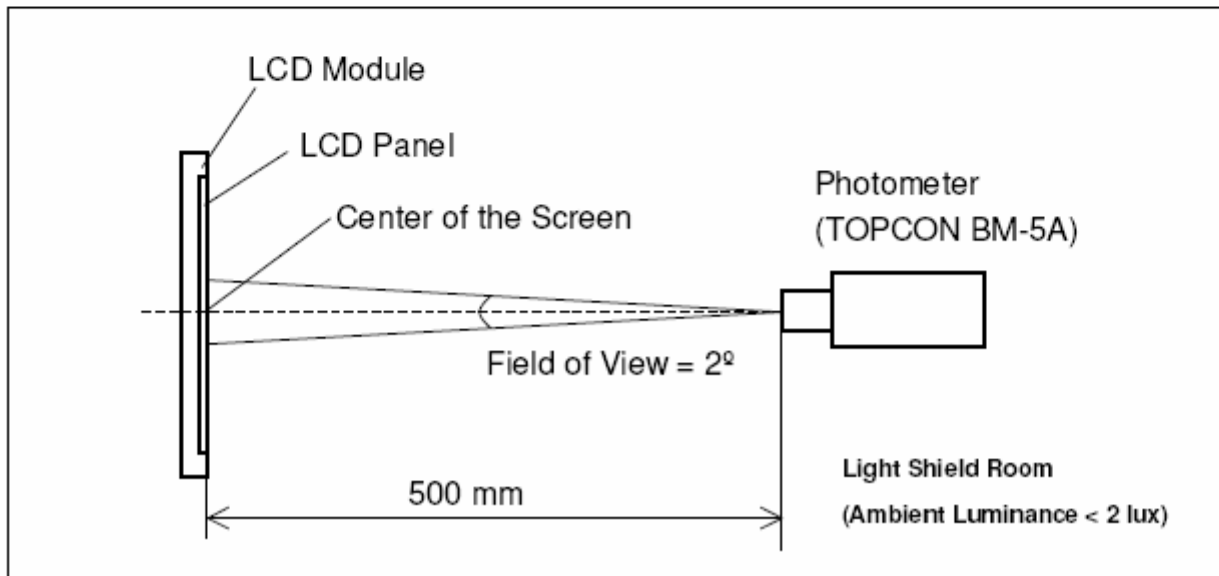

Note (5)

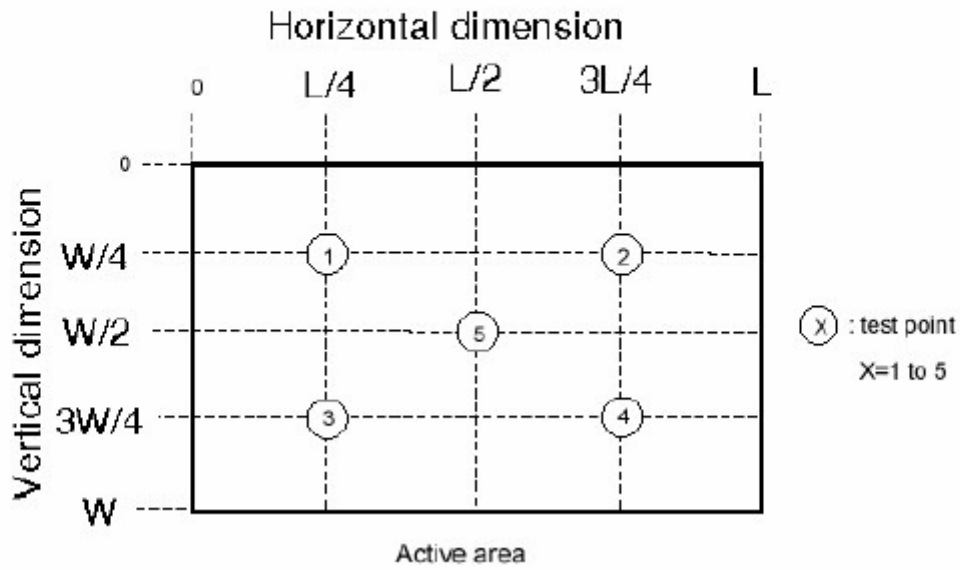

## 5. Electrical Characteristics

### 5.1 Absolute Maximum Rating (Ta=25 VSS=0V)

Characteristics	Symbol	Min.	Max.	Unit
Digital Supply Voltage	VDD	3.0	5.0	V
Digital interface supply Voltage	VDDIO	-0.3	4.0	V
Operating temperature	T <sub>OP</sub>	-20	+70	°C
Storage temperature	T <sub>ST</sub>	-30	+80	°C

### 5.2 DC Electrical Characteristics

Characteristics	Symbol	Min.	Typ.	Max.	Unit	Note
Digital Supply Voltage	VDD	3.0	3.3	3.6	V	
Digital interface supply Voltage	VDDIO	1.6	3.3	3.6	V	
Normal mode Current consumption	IDD	--	10	--	mA	
Level input voltage	V <sub>IH</sub>	0.7V <sub>DDIO</sub>		V <sub>DDIO</sub>	V	
	V <sub>IL</sub>	GND		0.3V <sub>DDIO</sub>	V	
Level output voltage	V <sub>OH</sub>	V <sub>DDIO</sub> -0.4		-	V	
	V <sub>OL</sub>	GND		GND+0.4	V	

### 5.3 LED Backlight Characteristics

The back-light system is edge-lighting type with 6 chips White LED

Item	Symbol	Min.	Typ.	Max.	Unit	Note
Forward Current	$I_F$	15	20	-	mA	
Forward Voltage	$V_F$	--	19.2	--	V	
LCM Luminance	$L_V$	400	--	--	cd/m <sup>2</sup>	IF=20mA
Uniformity	AVg	80	--	--	%	

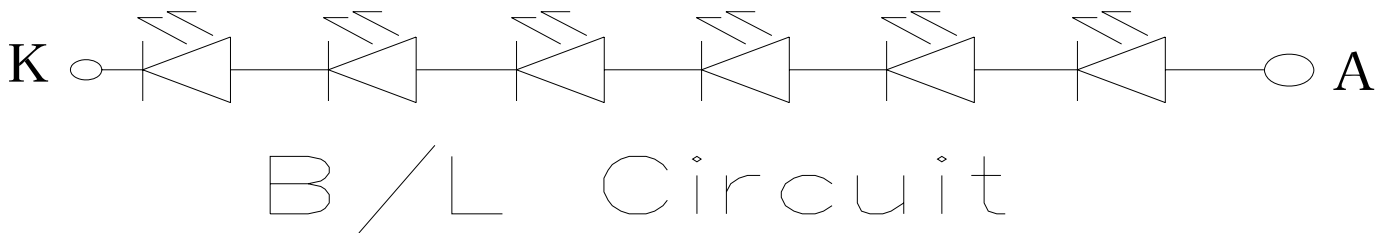

## 6. AC Characteristic

### 6.1. Input signal characteristics

AC Electrical Characteristics (VDDIO=VDD=3.0 to 3.6v, GND=0V, TA=-20 to +85 °C°C°C°C)

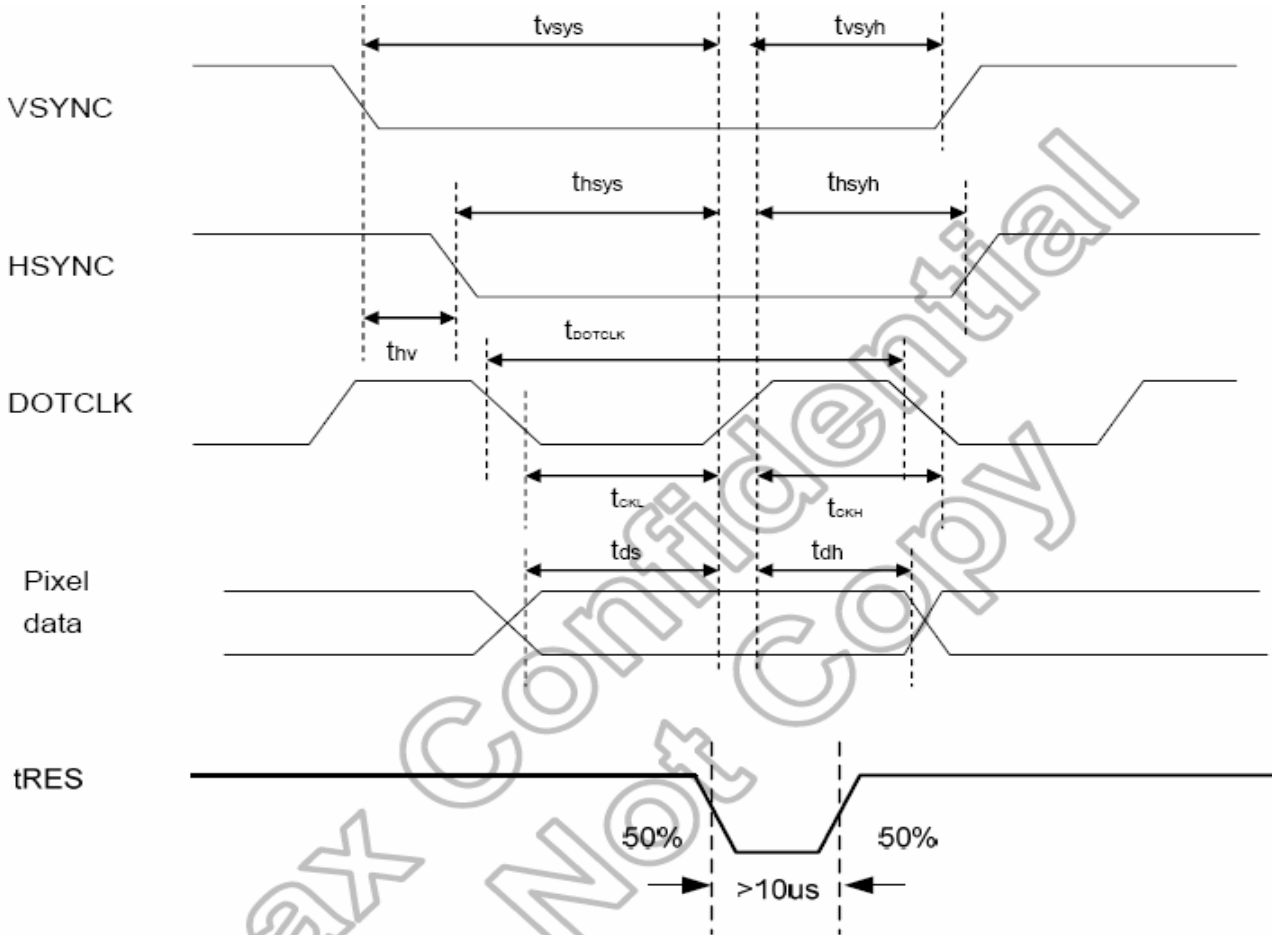

Characteristics	Symbol	Min.		Typ.		Max.		Unit
		24 bit	8 bit	24 bit	8 bit	24 bit	8 bit	
DOTCLK Frequency	fDOTCLK	-	-	6.5	19.5	10	30	MHz
DOTCLK Period	tDOTCLK	100	33.3	154	51.3	-	-	ns
Vertical Sync Setup Time	tvsys	20	10	-	-	-	-	ns
Vertical Sync Hold Time	tvsyh	20	10	-	-	-	-	ns
Horizontal Sync Setup Time	thsys	20	10	-	-	-	-	ns
Horizontal Sync Hold Time	thsyh	20	10	-	-	-	-	ns
Phase difference of Sync Signal Falling Edge	thv	1		-		240		tDOTCLK
DOTCLK Low Period	tCKL	50	15	-	-	-	-	ns
DOTCLK High Period	tCKH	50	15	-	-	-	-	ns
Data Setup Time	tds	12	10	-	-	-	-	ns
Data hold Time	tdh	12	10	-	-	-	-	ns
Reset pulse width	tRES	10		-		-		μs

**Note:** External clock source must be provided to DOTCLK pin of HX8238-D. The driver will not operate if absent of the clocking signal.

## 7. Waveform

### 7.1. Timing Chart

#### 7.1.1. Clock and Data Input Waveforms

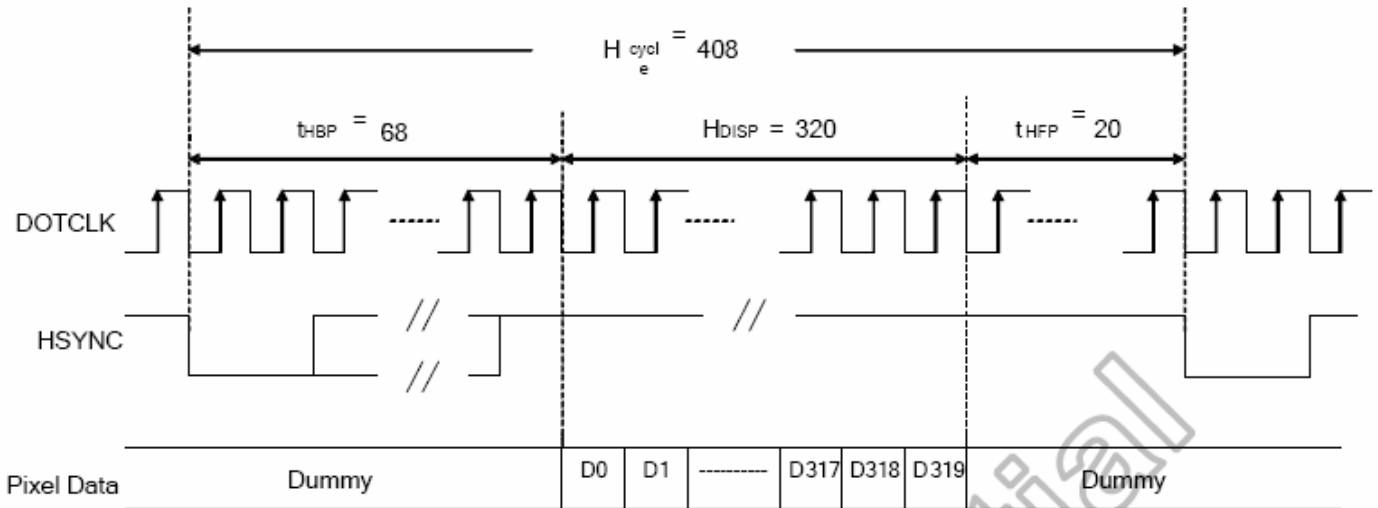

(a) Horizontal Data Transaction Timing

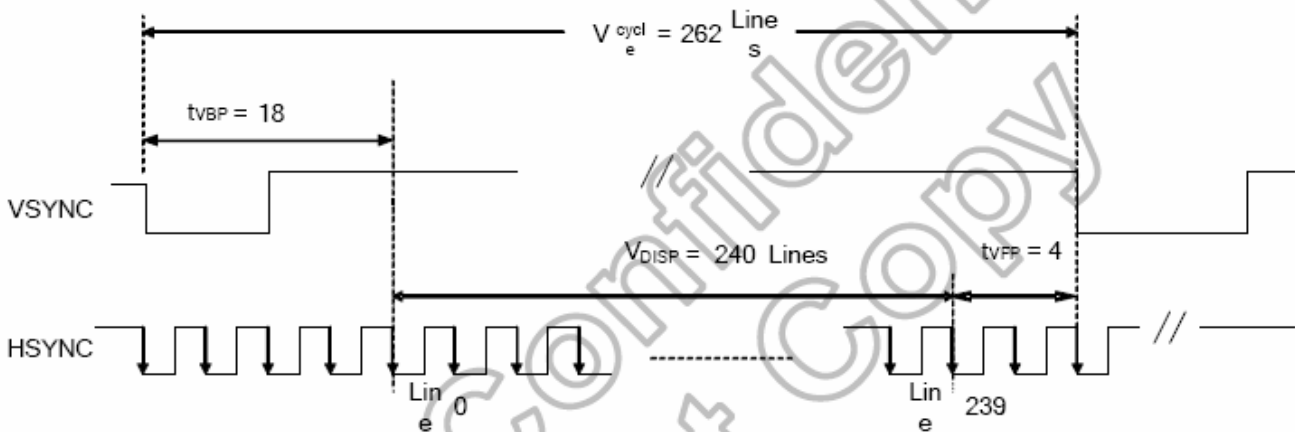

(b) Vertical Data Transaction Timing



Characteristics	Symbol	Min.		Typ.		Max.		Unit
		24 bit	8 bit	24 bit	8 bit	24 bit	8 bit	
DOTCLK Frequency	fDOTCLK	-	-	6.5	19.5	10	30	MHz
DOTCLK Period	tDOTCLK	100	33.3	154	51.3	-	-	ns
Horizontal Frequency (Line)	fH	-		14.9		22.35		KHz
Vertical Frequency (Refresh)	fV	-		60		90		Hz
Horizontal Back Porch	tHBP	-	-	68	204	-	-	tDOTCLK
Horizontal Front Porch	tHFP	-	-	20	60	-	-	tDOTCLK
Horizontal Data Start Point	tHBP	-	-	68	204	-	-	tDOTCLK
Horizontal Blanking Period	tHBP + tHFP	-	-	88	264	-	-	tDOTCLK
Horizontal Display Area	HDISP	-	-	320	960	-	-	tDOTCLK
Horizontal Cycle	Hcycle	-	-	408	1224	450	1350	tDOTCLK
Vertical Back Porch	tVBP	-		18		-		Lines
Vertical Front Porch	tVFP	-		4		-		Lines
Vertical Data Start Point	tVBP	-		18		-		Lines
Vertical Blanking Period	tVBP + tVFP	-		22		-		Lines
Vertical Display Area	NTSC	-		240		-		Lines
	PAL			280(PALM=0)				
	PAL			288(PALM=1)				
Vertical Cycle	NTSC	-		262		350		Lines
	PAL			313				

## 8. LCD Module Out-Going Quality Level

### 8.1 VISUAL & FUNCTION INSPECTION STANDARD

#### 8.1.1 Inspection conditions

Inspection performed under the following conditions is recommended.

Temperature :  $25 \pm 5^{\circ}\text{C}$

Humidity :  $65\% \pm 10\% \text{RH}$

Viewing Angle : Normal viewing Angle.

Illumination: Single fluorescent lamp (300 to 700Lux)

Viewing distance: 30–50cm

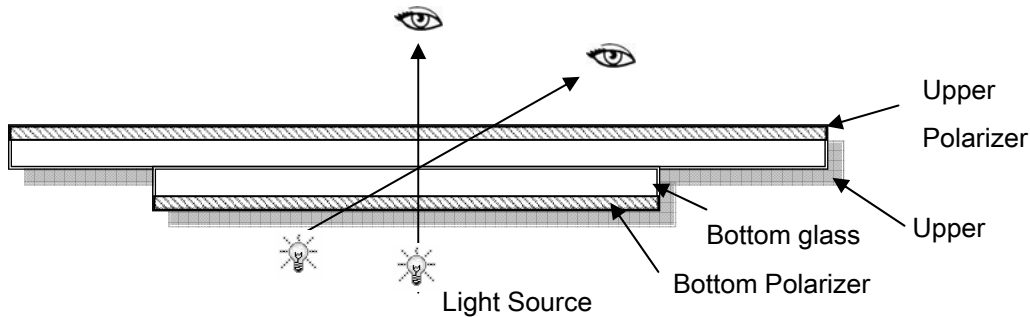

#### 8.1.2 Definition

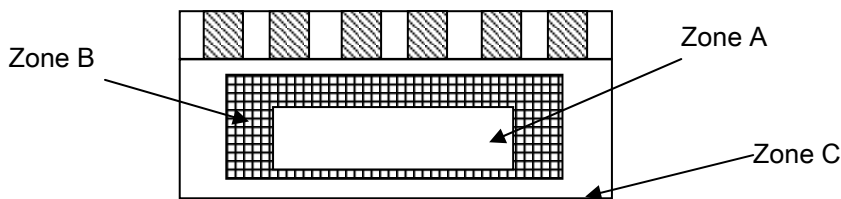

Zone A : Effective Viewing Area (Character or Digit can be seen)

Zone B : Viewing Area except Zone A

Zone C : Outside (Zone A+Zone B) which can not be seen after assembly by customer .)

Note:

As a general rule ,visual defects in Zone C can be ignored when it doesn't effect product function or appearance after assembly by customer.

### 8.1.3 Sampling Plan

According to GB/T 2828-2003 ; , normal inspection, Class II

AQL:

Major defect	Minor defect
0.65	1.5

LCD: Liquid Crystal Display , TP: Touch Panel , LCM: Liquid Crystal Module

No	Items to be inspected	Criteria	Classification of defects
1	Functional defects	1) No display, Open or miss line 2) Display abnormally, Short 3) Backlight no lighting, abnormal lighting. 4) TP no function	Major
2	Missing	Missing component	
3	Outline dimension	Overall outline dimension beyond the drawing is not allowed	
4	Color tone	Color unevenness, refer to limited sample	Minor
5	Soldering appearance	Good soldering , Peeling off is not allowed.	
6	LCD/Polarizer/TP	Black/White spot/line, scratch, crack, etc.	

### 8.1.4 Criteria (Visual)

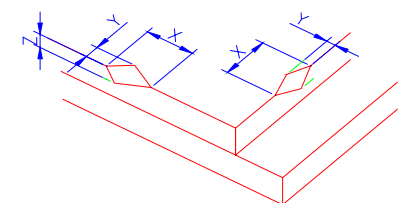
Number	Items	Criteria(mm)						
1.0 LCD Crack/Broken	(1) The edge of LCD broken	 <table border="1" data-bbox="861 1657 1388 1803"> <tr> <td>X</td> <td>Y</td> <td>Z</td> </tr> <tr> <td>≤3.0mm</td> <td>&lt;Inner border line of the seal</td> <td>≤T</td> </tr> </table>	X	Y	Z	≤3.0mm	<Inner border line of the seal	≤T
X	Y	Z						
≤3.0mm	<Inner border line of the seal	≤T						
NOTE: X: Length Y: Width								

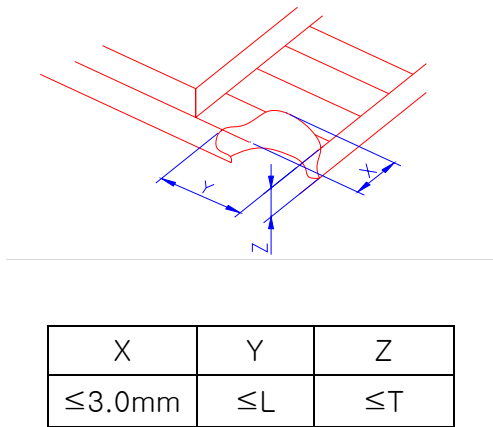
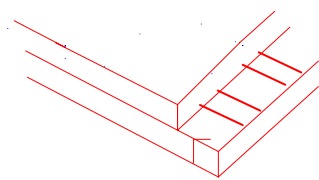
<p>Z: Height L: Length of ITO, T: Height of LCD</p>	<p>(2)LCD corner broken</p>	 <table border="1" data-bbox="922 548 1332 649"> <tr> <td>X</td> <td>Y</td> <td>Z</td> </tr> <tr> <td>≤3.0mm</td> <td>≤L</td> <td>≤T</td> </tr> </table>	X	Y	Z	≤3.0mm	≤L	≤T
	X	Y	Z					
≤3.0mm	≤L	≤T						
<p>(3) LCD crack</p>	 <p>Crack Not allowed</p>							

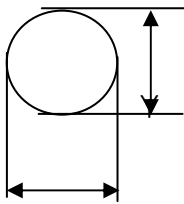
Number	Items	Criteria (mm)																								
2.0	Spot defect  $\Phi = (X+Y)/2$	① light dot (LCD/TP/Polarizer black/white spot , light dot, pinhole, dent, stain) <table border="1"> <thead> <tr> <th rowspan="2">Zone Size (mm)</th> <th colspan="3">Acceptable Qty</th> </tr> <tr> <th>A</th> <th>B</th> <th>C</th> </tr> </thead> <tbody> <tr> <td><math>\Phi \leq 0.10</math></td> <td colspan="3">Ignore</td> </tr> <tr> <td><math>0.10 &lt; \Phi \leq 0.15</math></td> <td colspan="3">3( distance <math>\geq 10\text{mm}</math>)</td> </tr> <tr> <td><math>0.15 &lt; \Phi \leq 0.2</math></td> <td colspan="3">1</td> </tr> <tr> <td><math>0.2 &lt; \Phi</math></td> <td colspan="3">0</td> </tr> </tbody> </table>	Zone Size (mm)	Acceptable Qty			A	B	C	$\Phi \leq 0.10$	Ignore			$0.10 < \Phi \leq 0.15$	3( distance $\geq 10\text{mm}$ )			$0.15 < \Phi \leq 0.2$	1			$0.2 < \Phi$	0			
		Zone Size (mm)		Acceptable Qty																						
			A	B	C																					
		$\Phi \leq 0.10$	Ignore																							
		$0.10 < \Phi \leq 0.15$	3( distance $\geq 10\text{mm}$ )																							
		$0.15 < \Phi \leq 0.2$	1																							
		$0.2 < \Phi$	0																							
		② Dim spot (LCD/TP/Polarizer dim dot, light leakage、 dark spot) <table border="1"> <thead> <tr> <th rowspan="2">Zone Size (mm)</th> <th colspan="3">Acceptable Qty</th> </tr> <tr> <th>A</th> <th>B</th> <th>C</th> </tr> </thead> <tbody> <tr> <td><math>\Phi \leq 0.1</math></td> <td colspan="3">Ignore</td> </tr> <tr> <td><math>0.1 &lt; \Phi \leq 0.2</math></td> <td colspan="3">2( distance <math>\geq 10\text{mm}</math>)</td> </tr> <tr> <td><math>0.2 &lt; \Phi \leq 0.3</math></td> <td colspan="3">1</td> </tr> <tr> <td><math>\Phi &gt; 0.3</math></td> <td colspan="3">0</td> </tr> </tbody> </table>	Zone Size (mm)	Acceptable Qty			A	B	C	$\Phi \leq 0.1$	Ignore			$0.1 < \Phi \leq 0.2$	2( distance $\geq 10\text{mm}$ )			$0.2 < \Phi \leq 0.3$	1			$\Phi > 0.3$	0			
		Zone Size (mm)		Acceptable Qty																						
			A	B	C																					
$\Phi \leq 0.1$	Ignore																									
$0.1 < \Phi \leq 0.2$	2( distance $\geq 10\text{mm}$ )																									
$0.2 < \Phi \leq 0.3$	1																									
$\Phi > 0.3$	0																									
③ Polarizer accidented spot <table border="1"> <thead> <tr> <th rowspan="2">Zone Size (mm)</th> <th colspan="3">Acceptable Qty</th> </tr> <tr> <th>A</th> <th>B</th> <th>C</th> </tr> </thead> <tbody> <tr> <td><math>\Phi \leq 0.2</math></td> <td colspan="3">Ignore</td> </tr> <tr> <td><math>0.2 &lt; \Phi \leq 0.5</math></td> <td colspan="3">2( distance <math>\geq 10\text{mm}</math>)</td> </tr> <tr> <td><math>\Phi &gt; 0.5</math></td> <td colspan="3">0</td> </tr> </tbody> </table>	Zone Size (mm)	Acceptable Qty			A	B	C	$\Phi \leq 0.2$	Ignore			$0.2 < \Phi \leq 0.5$	2( distance $\geq 10\text{mm}$ )			$\Phi > 0.5$	0									
Zone Size (mm)		Acceptable Qty																								
	A	B	C																							
$\Phi \leq 0.2$	Ignore																									
$0.2 < \Phi \leq 0.5$	2( distance $\geq 10\text{mm}$ )																									
$\Phi > 0.5$	0																									
Line defect (LCD/TP /Polarizer black/white line, scratch, stain) <table border="1"> <thead> <tr> <th rowspan="2">Width(mm)</th> <th rowspan="2">Length(mm)</th> <th colspan="3">Acceptable Qty</th> </tr> <tr> <th>A</th> <th>B</th> <th>C</th> </tr> </thead> <tbody> <tr> <td><math>\Phi \leq 0.03</math></td> <td>Ignore</td> <td colspan="2">Ignore</td> <td rowspan="3">Ignore</td> </tr> <tr> <td><math>0.03 &lt; W \leq 0.05</math></td> <td><math>L \leq 3.0</math></td> <td colspan="2"><math>N \leq 2</math></td> </tr> <tr> <td><math>0.05 &lt; W \leq 0.08</math></td> <td><math>L \leq 2.0</math></td> <td colspan="2"><math>N \leq 2</math></td> </tr> <tr> <td><math>0.08 &lt; W</math></td> <td colspan="4">Define as spot defect</td> </tr> </tbody> </table>	Width(mm)	Length(mm)	Acceptable Qty			A	B	C	$\Phi \leq 0.03$	Ignore	Ignore		Ignore	$0.03 < W \leq 0.05$	$L \leq 3.0$	$N \leq 2$		$0.05 < W \leq 0.08$	$L \leq 2.0$	$N \leq 2$		$0.08 < W$	Define as spot defect			
Width(mm)			Length(mm)	Acceptable Qty																						
	A	B		C																						
$\Phi \leq 0.03$	Ignore	Ignore		Ignore																						
$0.03 < W \leq 0.05$	$L \leq 3.0$	$N \leq 2$																								
$0.05 < W \leq 0.08$	$L \leq 2.0$	$N \leq 2$																								
$0.08 < W$	Define as spot defect																									

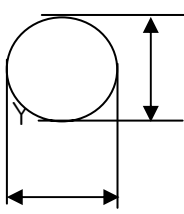

Items	Criteria (mm)																																																									
<p>Spot defect</p>  <p>X</p> <p>Y</p> <p><math>\Phi = (X+Y)/2</math></p>	<p>① light dot (LCD/TP/Polarizer black/white spot , light dot, pinhole, dent, stain)</p> <table border="1" data-bbox="406 739 1340 1086"> <thead> <tr> <th rowspan="2">Zone Size (mm)</th> <th colspan="3">Acceptable Qty</th> </tr> <tr> <th>A</th> <th>B</th> <th>C</th> </tr> </thead> <tbody> <tr> <td><math>\Phi \leq 0.10</math></td> <td colspan="2">Ignore</td> <td rowspan="4">Ignore</td> </tr> <tr> <td><math>0.10 &lt; \Phi \leq 0.15</math></td> <td colspan="2">3( distance <math>\geq 10\text{mm}</math>)</td> </tr> <tr> <td><math>0.15 &lt; \Phi \leq 0.2</math></td> <td colspan="2">1</td> </tr> <tr> <td><math>0.2 &lt; \Phi</math></td> <td colspan="2">0</td> </tr> </tbody> </table> <p>② Dim spot (LCD/TP/Polarizer dim dot, light leakage, dark spot)</p> <table border="1" data-bbox="406 1187 1364 1534"> <thead> <tr> <th rowspan="2">Zone Size (mm)</th> <th colspan="3">Acceptable Qty</th> </tr> <tr> <th>A</th> <th>B</th> <th>C</th> </tr> </thead> <tbody> <tr> <td><math>\Phi \leq 0.1</math></td> <td colspan="2">Ignore</td> <td rowspan="4">Ignore</td> </tr> <tr> <td><math>0.1 &lt; \Phi \leq 0.2</math></td> <td colspan="2">2( distance <math>\geq 10\text{mm}</math>)</td> </tr> <tr> <td><math>0.2 &lt; \Phi \leq 0.3</math></td> <td colspan="2">1</td> </tr> <tr> <td><math>\Phi &gt; 0.3</math></td> <td colspan="2">0</td> </tr> </tbody> </table> <p>③ Polarizer accidented spot</p> <table border="1" data-bbox="406 1635 1228 1926"> <thead> <tr> <th rowspan="2">Zone Size (mm)</th> <th colspan="3">Acceptable Qty</th> </tr> <tr> <th>A</th> <th>B</th> <th>C</th> </tr> </thead> <tbody> <tr> <td><math>\Phi \leq 0.2</math></td> <td colspan="2">Ignore</td> <td rowspan="3">Ignore</td> </tr> <tr> <td><math>0.2 &lt; \Phi \leq 0.5</math></td> <td colspan="2">2( distance <math>\geq 10\text{mm}</math>)</td> </tr> <tr> <td><math>\Phi &gt; 0.5</math></td> <td colspan="2">0</td> </tr> </tbody> </table>	Zone Size (mm)	Acceptable Qty			A	B	C	$\Phi \leq 0.10$	Ignore		Ignore	$0.10 < \Phi \leq 0.15$	3( distance $\geq 10\text{mm}$ )		$0.15 < \Phi \leq 0.2$	1		$0.2 < \Phi$	0		Zone Size (mm)	Acceptable Qty			A	B	C	$\Phi \leq 0.1$	Ignore		Ignore	$0.1 < \Phi \leq 0.2$	2( distance $\geq 10\text{mm}$ )		$0.2 < \Phi \leq 0.3$	1		$\Phi > 0.3$	0		Zone Size (mm)	Acceptable Qty			A	B	C	$\Phi \leq 0.2$	Ignore		Ignore	$0.2 < \Phi \leq 0.5$	2( distance $\geq 10\text{mm}$ )		$\Phi > 0.5$	0	
Zone Size (mm)	Acceptable Qty																																																									
	A	B	C																																																							
$\Phi \leq 0.10$	Ignore		Ignore																																																							
$0.10 < \Phi \leq 0.15$	3( distance $\geq 10\text{mm}$ )																																																									
$0.15 < \Phi \leq 0.2$	1																																																									
$0.2 < \Phi$	0																																																									
Zone Size (mm)	Acceptable Qty																																																									
	A	B	C																																																							
$\Phi \leq 0.1$	Ignore		Ignore																																																							
$0.1 < \Phi \leq 0.2$	2( distance $\geq 10\text{mm}$ )																																																									
$0.2 < \Phi \leq 0.3$	1																																																									
$\Phi > 0.3$	0																																																									
Zone Size (mm)	Acceptable Qty																																																									
	A	B	C																																																							
$\Phi \leq 0.2$	Ignore		Ignore																																																							
$0.2 < \Phi \leq 0.5$	2( distance $\geq 10\text{mm}$ )																																																									
$\Phi > 0.5$	0																																																									



Line defect (LCD/TP /Polarizer black/white line, scratch, stain)	<table border="1"> <thead> <tr> <th rowspan="2">Width(mm)</th> <th rowspan="2">Length(mm)</th> <th colspan="3">Acceptable Qty</th> </tr> <tr> <th>A</th> <th>B</th> <th>C</th> </tr> </thead> <tbody> <tr> <td><math>\Phi \leq 0.03</math></td> <td>Ignore</td> <td colspan="2">Ignore</td> <td rowspan="3">Ignore</td> </tr> <tr> <td><math>0.03 &lt; W \leq 0.05</math></td> <td><math>L \leq 3.0</math></td> <td colspan="2"><math>N \leq 2</math></td> </tr> <tr> <td><math>0.05 &lt; W \leq 0.08</math></td> <td><math>L \leq 2.0</math></td> <td colspan="2"><math>N \leq 2</math></td> </tr> <tr> <td><math>0.08 &lt; W</math></td> <td colspan="3">Define as spot defect</td> <td></td> </tr> </tbody> </table>	Width(mm)	Length(mm)	Acceptable Qty			A	B	C	$\Phi \leq 0.03$	Ignore	Ignore		Ignore	$0.03 < W \leq 0.05$	$L \leq 3.0$	$N \leq 2$		$0.05 < W \leq 0.08$	$L \leq 2.0$	$N \leq 2$		$0.08 < W$	Define as spot defect			
	Width(mm)			Length(mm)	Acceptable Qty																						
A		B	C																								
$\Phi \leq 0.03$	Ignore	Ignore		Ignore																							
$0.03 < W \leq 0.05$	$L \leq 3.0$	$N \leq 2$																									
$0.05 < W \leq 0.08$	$L \leq 2.0$	$N \leq 2$																									
$0.08 < W$	Define as spot defect																										
Polarizer Bubble	<table border="1"> <thead> <tr> <th rowspan="2">Zone Size (mm)</th> <th colspan="3">Acceptable Qty</th> </tr> <tr> <th>A</th> <th>B</th> <th>C</th> </tr> </thead> <tbody> <tr> <td><math>\Phi \leq 0.2</math></td> <td colspan="2">Ignore</td> <td rowspan="4">Ignore</td> </tr> <tr> <td><math>0.2 &lt; \Phi \leq 0.4</math></td> <td colspan="2">2(distance <math>\geq 10\text{mm}</math>)</td> </tr> <tr> <td><math>0.4 &lt; \Phi \leq 0.6</math></td> <td colspan="2">1</td> </tr> <tr> <td><math>0.6 &lt; \Phi</math></td> <td colspan="2">0</td> </tr> </tbody> </table>	Zone Size (mm)	Acceptable Qty			A	B	C	$\Phi \leq 0.2$	Ignore		Ignore	$0.2 < \Phi \leq 0.4$	2(distance $\geq 10\text{mm}$ )		$0.4 < \Phi \leq 0.6$	1		$0.6 < \Phi$	0							
Zone Size (mm)	Acceptable Qty																										
	A	B	C																								
$\Phi \leq 0.2$	Ignore		Ignore																								
$0.2 < \Phi \leq 0.4$	2(distance $\geq 10\text{mm}$ )																										
$0.4 < \Phi \leq 0.6$	1																										
$0.6 < \Phi$	0																										
SMT	According to IPC-A-610C class II standard . Function defect and missing part are major defect ,the others are minor defect.																										

TP bubble/ accidented spot	<table border="1"> <thead> <tr> <th rowspan="2">Size <math>\Phi</math>(mm)</th> <th colspan="3">Acceptable Qty</th> </tr> <tr> <th>A</th> <th>B</th> <th>C</th> </tr> </thead> <tbody> <tr> <td><math>\Phi \leq 0.1</math></td> <td colspan="2">Ignore</td> <td rowspan="4">Ignore</td> </tr> <tr> <td><math>0.1 &lt; \Phi \leq 0.2</math></td> <td colspan="2">2</td> </tr> <tr> <td><math>0.2 &lt; \Phi \leq 0.3</math></td> <td colspan="2">1</td> </tr> <tr> <td><math>0.3 &lt; \Phi</math></td> <td colspan="2">0</td> </tr> </tbody> </table>	Size $\Phi$ (mm)	Acceptable Qty			A	B	C	$\Phi \leq 0.1$	Ignore		Ignore	$0.1 < \Phi \leq 0.2$	2		$0.2 < \Phi \leq 0.3$	1		$0.3 < \Phi$	0	
	Size $\Phi$ (mm)		Acceptable Qty																		
A		B	C																		
$\Phi \leq 0.1$	Ignore		Ignore																		
$0.1 < \Phi \leq 0.2$	2																				
$0.2 < \Phi \leq 0.3$	1																				
$0.3 < \Phi$	0																				
Assembly deflection	beyond the edge of backlight $\leq 0.15\text{mm}$																				

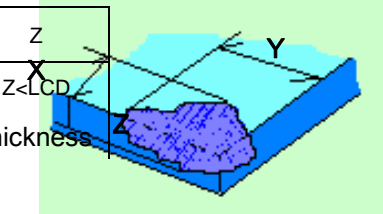
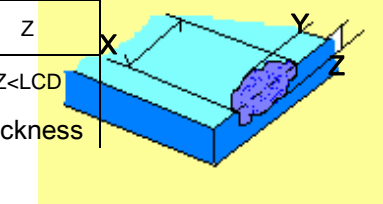
5.0	TP Related	Newton Ring	<p>Newton area &gt; 1/3 TP Ring area NG</p> <p>Newton area ≤ 1/3 TP Ring area OK</p>					
TP corner broken		<p>X : length</p> <p>Y : width</p> <p>Z : height</p>	<table border="1" data-bbox="592 1099 890 1249"> <tr> <td>X</td> <td>Y</td> </tr> <tr> <td>X ≤ 3.0mm</td> <td>Y ≤ 3.0mm</td> </tr> </table> <p>* Circuitry broken is not allowed.</p>	X	Y	X ≤ 3.0mm	Y ≤ 3.0mm	
X	Y							
X ≤ 3.0mm	Y ≤ 3.0mm							
TP edge broken		<p>X : length</p> <p>Y : width</p> <p>Z : height</p>	<table border="1" data-bbox="592 1435 890 1585"> <tr> <td>X</td> <td>Y</td> </tr> <tr> <td>X ≤ 6.0mm</td> <td>Y ≤ 2.0mm</td> </tr> </table> <p>* Circuitry broken is not allowed.</p>	X	Y	X ≤ 6.0mm	Y ≤ 2.0mm	
X	Y							
X ≤ 6.0mm	Y ≤ 2.0mm							



Criteria ( functional items)

Number	Items	Criteria (mm)
1	No display	Not allowed
2	Missing segment	Not allowed
3	Short	Not allowed
4	Backlight no lighting	Not allowed
5	TP no function	Not allowed

## 9. Reliability Test Result

### 9.1 Condition

Item	Condition	Sample Size	Test Result	Note
Low Temperature Operating Life test	-20℃, 96HR	3ea	pass	-
Thermal Humidity Operating Life test	60℃, 90%RH, 96HR	3ea	pass	-
Temperature Cycle ON/OFF test	-20℃ ↔ 70℃, ON/OFF, 20CYC	3ea	pass	(1)
High Temperature Storage test	80℃, 96HR	3ea	pass	-
Low Temperature Storage test	- 30℃, 96HR	3ea	pass	-
Thermal Shock Resistance	The sample should be allowed to stand the following 5 cycles of operation: TSTL for 30 minutes -> normal temperature for 5 minutes -> TSTH for 30 minutes -> normal temperature for 5 minutes, as one cycle, then taking it out and drying it at normal temperature, and allowing it stand for 24 hours	3ea	pass	
Box Drop Test	1 Corner 3 Edges 6 faces, 66cm(MEDIUM BOX)	1box	pass	-

Note (1) ON Time over 10 seconds, OFF Time under 10 seconds

## 10. Cautions and Handling Precautions

### 10.1 Handling and Operating the Module

(1) When the module is assembled, it should be attached to the system firmly.

Do not warp or twist the module during assembly work.

(2) Protect the module from physical shock or any force. In addition to damage, this may cause improper operation or damage to the module and back-light unit.

(3) Note that polarizer is very fragile and could be easily damaged. Do not press or scratch the surface.

(4) Do not allow drops of water or chemicals to remain on the display surface.

If you have the droplets for a long time, staining and discoloration may occur.

(5) If the surface of the polarizer is dirty, clean it using some absorbent cotton or soft cloth.

(6) The desirable cleaners are water, IPA (Isopropyl Alcohol) or Hexane.

Do not use ketene type materials (ex. Acetone), Ethyl alcohol, Toluene, Ethyl acid or Methyl chloride. It might permanent damage to the polarizer due to chemical reaction.

(7) If the liquid crystal material leaks from the panel, it should be kept away from the eyes or mouth. In case of contact with hands, legs, or clothes, it must be washed away thoroughly with soap.

(8) Protect the module from static; it may cause damage to the CMOS ICs.

(9) Use finger-stalls with soft gloves in order to keep display clean during the incoming inspection and assembly process.

(10) Do not disassemble the module.

(11) Protection film for polarizer on the module shall be slowly peeled off just before use so that the electrostatic charge can be minimized.

(12) Pins of I/F connector shall not be touched directly with bare hands.

(13) Do not connect, disconnect the module in the "Power ON" condition.

(14) Power supply should always be turned on/off by the item 6.1 Power On Sequence & 6.2 Power Off Sequence

### 10.2 Storage and Transportation.

(1) Do not leave the panel in high temperature, and high humidity for a long time.

It is highly recommended to store the module with temperature from 0 to 35 °C and relative humidity of less than 70%

(2) Do not store the TFT-LCD module in direct sunlight.

(3) The module shall be stored in a dark place. When storing the modules for a long time, be sure to adopt effective measures for protecting the modules from strong ultraviolet radiation, sunlight, or fluorescent light.

(4) It is recommended that the modules should be stored under a condition where no condensation is allowed. Formation of dewdrops may cause an abnormal operation or a failure of the module.

In particular, the greatest possible care should be taken to prevent any module from being operated where condensation has occurred inside.

(5) This panel has its circuitry FPC on the bottom side and should be handled carefully in order not to be stressed.

Part. No	KD035C-10F	REV	V1.0	Page 27 of 28
----------	------------	-----	------	---------------

## 11.Packing

-----TBD-----

Part. No	KD035C-10F	REV	V1.0	Page 28 of 28
----------	------------	-----	------	---------------